



Chipsmall Limited consists of a professional team with an average of over 10 year of expertise in the distribution of electronic components. Based in Hongkong, we have already established firm and mutual-benefit business relationships with customers from,Europe,America and south Asia,supplying obsolete and hard-to-find components to meet their specific needs.

With the principle of "Quality Parts,Customers Priority,Honest Operation,and Considerate Service",our business mainly focus on the distribution of electronic components. Line cards we deal with include Microchip,ALPS,ROHM,Xilinx,Pulse,ON,Everlight and Freescale. Main products comprise IC,Modules,Potentiometer,IC Socket,Relay,Connector.Our parts cover such applications as commercial,industrial, and automotives areas.

We are looking forward to setting up business relationship with you and hope to provide you with the best service and solution. Let us make a better world for our industry!



## Contact us

Tel: +86-755-8981 8866 Fax: +86-755-8427 6832

Email & Skype: info@chipsmall.com Web: www.chipsmall.com

Address: A1208, Overseas Decoration Building, #122 Zhenhua RD., Futian, Shenzhen, China



# 74ABT652A

Octal transceiver/register; non-inverting; 3-state

Rev. 02 — 12 March 2010

Product data sheet

## 1. General description

The 74ABT652A high-performance BiCMOS device combines low static and dynamic power dissipation with high speed and high output drive.

The 74ABT652A transceiver/register consists of bus transceiver circuits with 3-state outputs, D-type flip-flops, and control circuitry arranged for multiplexed transmission of data directly from the input bus or the internal registers. Data on the A or B bus will be clocked into the registers as the appropriate clock pin (CPAB or CPBA) goes HIGH. Output Enable (OEAB,  $\overline{OEBA}$ ) and Select (SAB, SBA) pins are provided for bus management.

## 2. Features and benefits

- Independent registers for A and B buses
- Multiplexed real-time and stored data
- 3-state outputs
- Live insertion/extraction permitted
- Power-up 3-state
- Power-up reset
- Output capability: +64 mA to -32 mA
- Latch-up protection exceeds 500 mA per JESD78B class II level A
- ESD protection:
  - ◆ HBM JESD22-A114F exceeds 2000 V
  - ◆ MM JESD22-A115-A exceeds 200 V

## 3. Ordering information

Table 1. Ordering information

Type number	Package			Version
	Temperature range	Name	Description	
74ABT652AD	-40 °C to +85 °C	SO24	plastic small outline package; 24 leads; body width 7.5 mm	SOT137-1
74ABT652ADB	-40 °C to +85 °C	SSOP24	plastic shrink small outline package; 24 leads; body width 5.3 mm	SOT340-1
74ABT652APW	-40 °C to +85 °C	TSSOP24	plastic thin shrink small outline package; 24 leads; body width 4.4 mm	SOT355-1



4. Block diagram

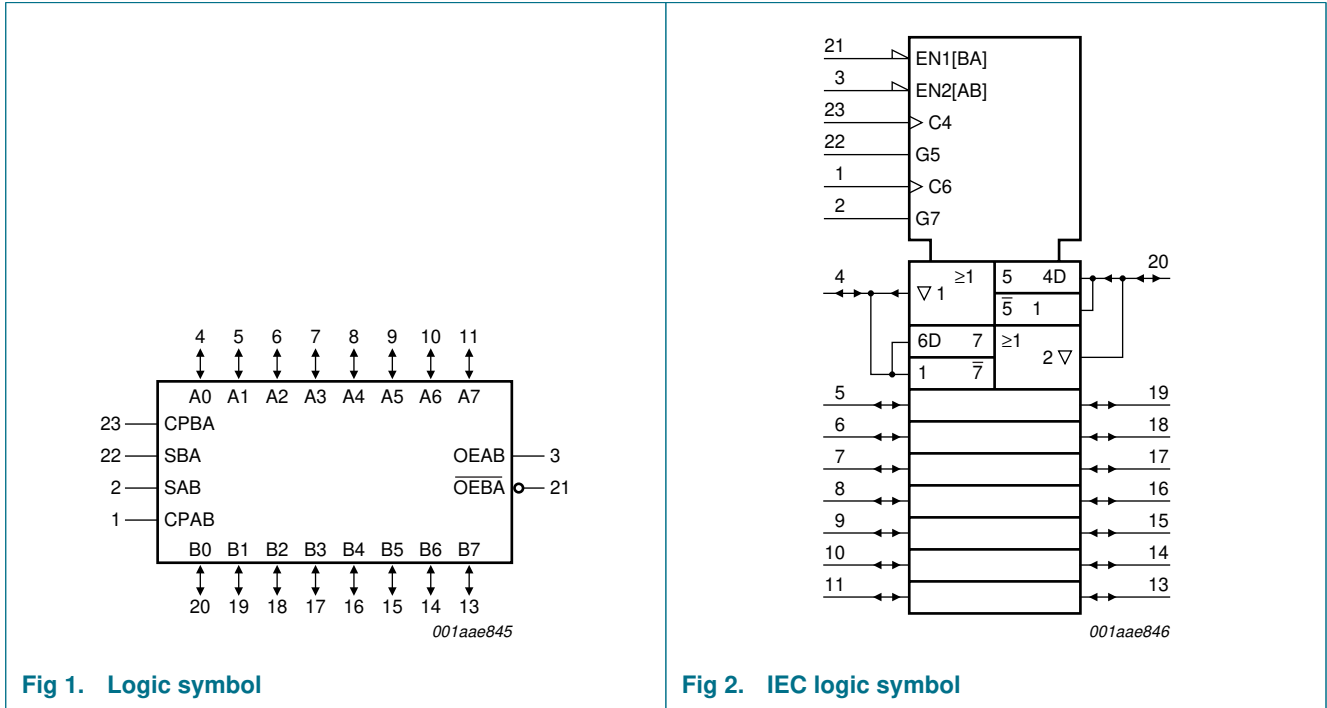

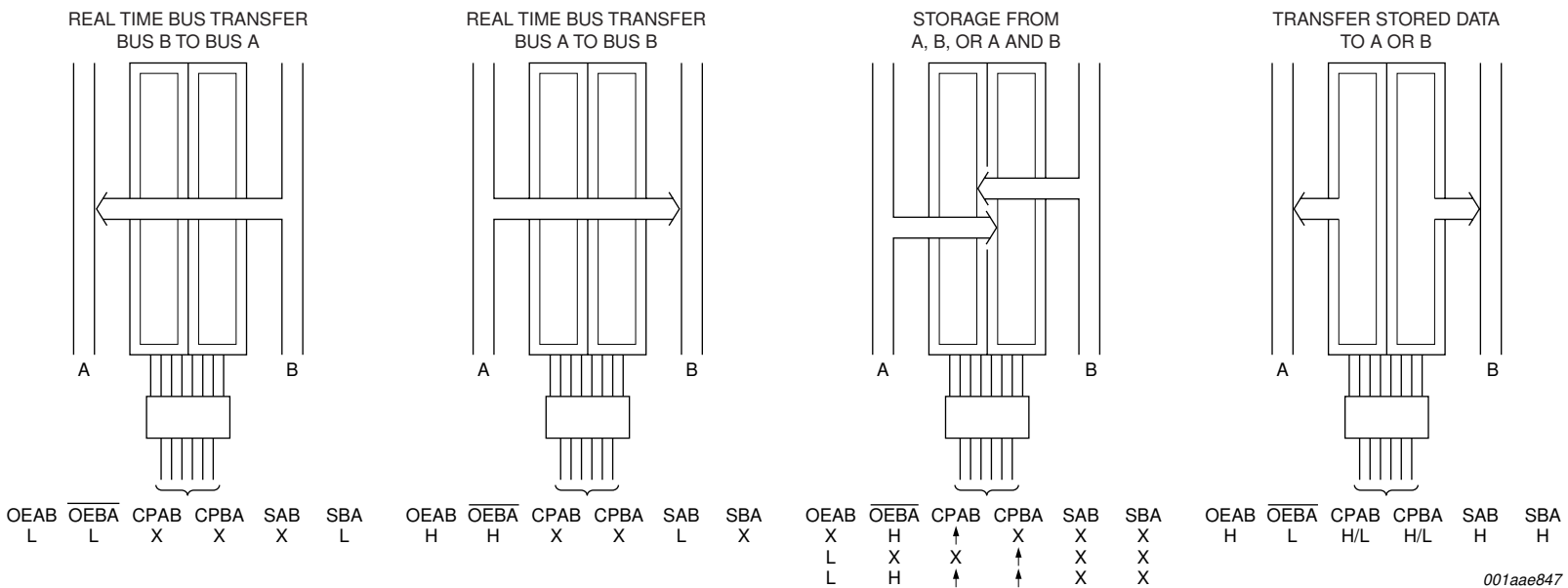

Fig 3. Real time bus transfer and storage

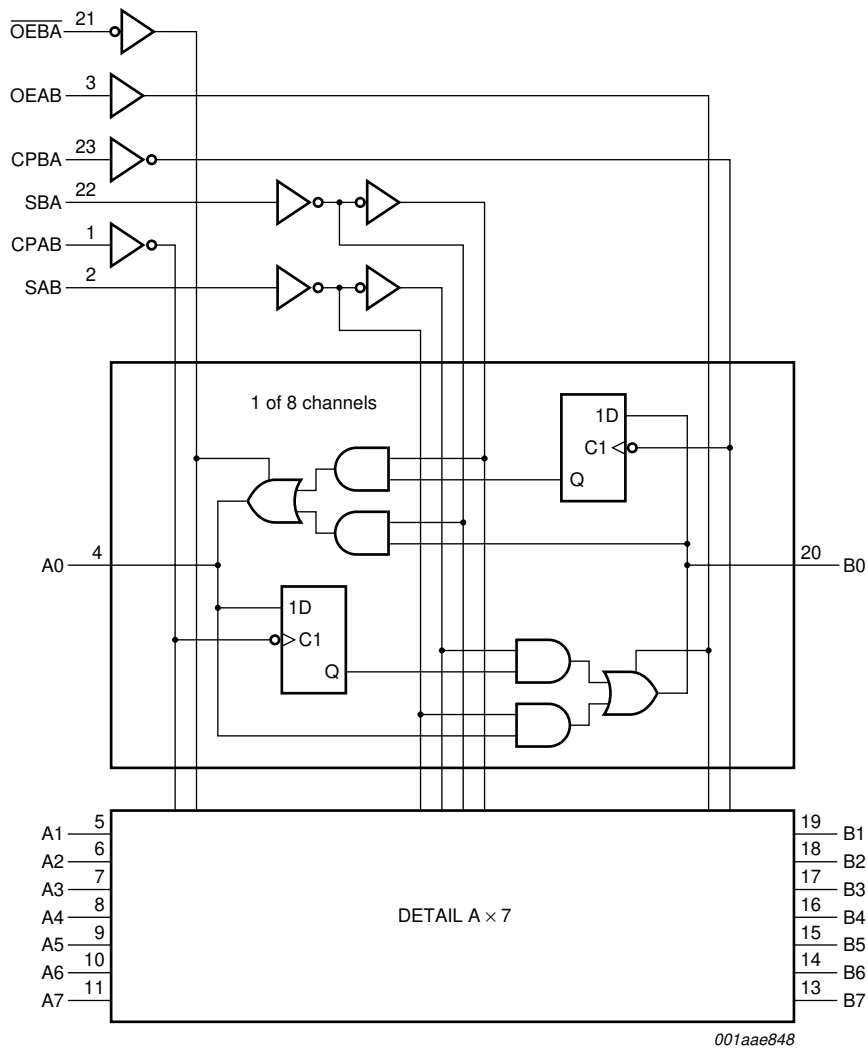

Fig 4. Logic diagram

## 5. Pinning information

### 5.1 Pinning

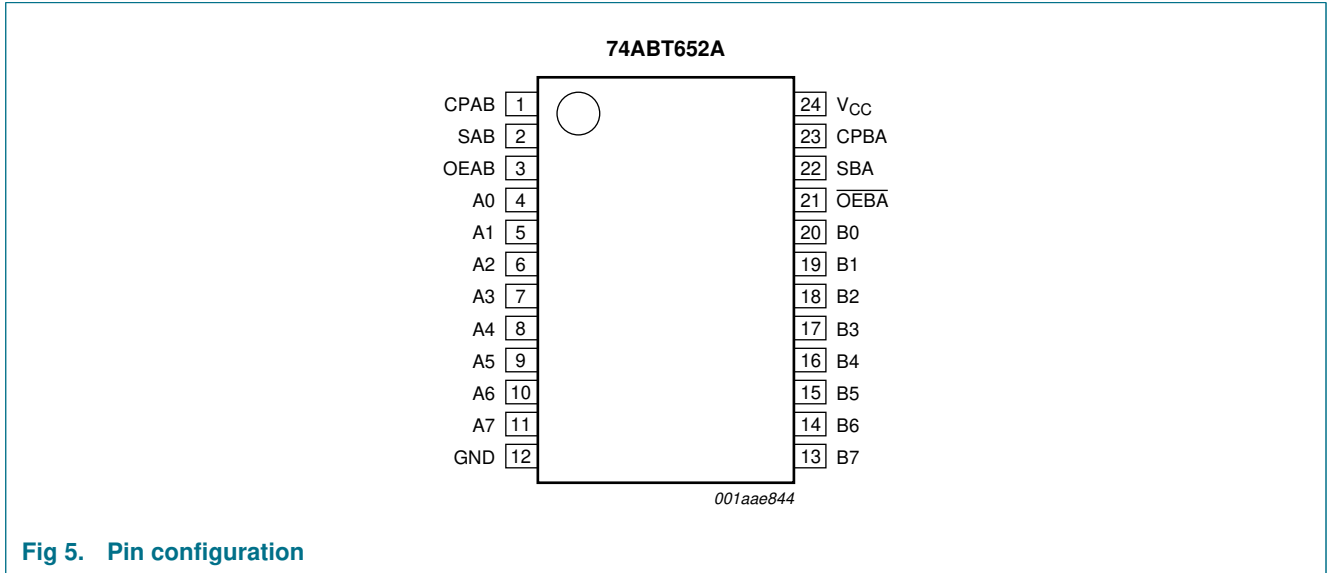

Fig 5. Pin configuration

### 5.2 Pin description

Table 2. Pin description

Symbol	Pin	Description
CPAB	1	A to B clock input
SAB	2	A to B select input
OEAB	3	A to B output enable input
A0, A1, A2, A3, A4, A5, A6, A7	4, 5, 6, 7, 8, 9, 10, 11	data input/output (A side)
GND	12	ground (0 V)
B0, B1, B2, B3, B4, B5, B6, B7	20, 19, 18, 17, 16, 15, 14, 13	data input/output (B side)
$\overline{OEBA}$	21	B to A output enable input (active LOW)
SBA	22	B to A select input
CPBA	23	B to A clock input
V <sub>CC</sub>	24	positive supply voltage

## 6. Functional description

### 6.1 Function table

Table 3. Function table [1]

Inputs						Data I/O		Operating mode
OEAB	OEBA	CPAB	CPBA	SAB	SBA	An	Bn	
L	H	H or L	H or L	X	X	input	input	isolation
L	H	↑	↑	X	X	input	input	store A and B data
X	H	↑	H or L	X	X	input	unspecified output [2]	store A, hold B
H	H	↑	↑	[3]	X	input	unspecified output [2]	store A in both registers
L	X	H or L	↑	X	X	unspecified output [2]	input	hold A, store B
L	L	↑	↑	X	[3]	unspecified output [2]	input	store B in both registers
L	L	X	X	X	L	output	input	real time B data to A bus
L	L	X	H or L	X	H	output	input	stored B data to A bus
H	H	X	X	L	X	input	output	real time A data to B bus
H	H	H or L	X	H	X	input	output	store A data to B bus
H	L	H or L	H or L	H	H	output	output	stored A data to B bus; stored B data to A bus

- [1] H = HIGH voltage level;  
L = LOW voltage level;  
X = don't care;  
↑ = LOW-to-HIGH clock transition.

- [2] The data output function may be enabled or disabled by various signals at the OEBA and OEAB inputs. Data input functions are always enabled, i.e., data at the bus pins will be stored on every LOW-to-HIGH transition of the clock.

- [3] If both select controls (SAB and SBA) are LOW, then clocks can occur simultaneously. If either select control is HIGH, the clocks must be staggered in order to load both registers.

[Figure 3](#) demonstrates the four fundamental bus-management functions that can be performed with the 74ABT652A.

The select pins determine whether data is stored or transferred through the device in real time.

The output enable pins determine the direction of the data flow.

## 7. Limiting values

**Table 4. Limiting values**

In accordance with the Absolute Maximum Rating System (IEC 60134).

Symbol	Parameter	Conditions	Min	Max	Unit
$V_{CC}$	supply voltage		-0.5	+7.0	V
$V_I$	input voltage		[1] -1.2	+7.0	V
$V_O$	output voltage	output in OFF-state or HIGH-state	[1] -0.5	+5.5	V
$I_{IK}$	input clamping current	$V_I < 0$ V	-18	-	mA
$I_{OK}$	output clamping current	$V_O < 0$ V	-50	-	mA
$I_O$	output current	output in LOW-state	-	128	mA
$T_j$	junction temperature		[2] -	150	°C
$T_{stg}$	storage temperature		-65	+150	°C

[1] The input and output voltage ratings may be exceeded if the input and output current ratings are observed.

[2] The performance capability of a high-performance integrated circuit in conjunction with its thermal environment can create junction temperatures which are detrimental to reliability. The maximum junction temperature of this integrated circuit should not exceed 150 °C.

## 8. Recommended operating conditions

**Table 5. Recommended operating conditions**

Symbol	Parameter	Conditions	Min	Typ	Max	Unit
$V_{CC}$	supply voltage		4.5	-	5.5	V
$V_I$	input voltage		0	-	$V_{CC}$	V
$V_{IH}$	HIGH-level input voltage		2.0	-	-	V
$V_{IL}$	LOW-level input voltage		-	-	0.8	V
$I_{OH}$	HIGH-level output current		-32	-	-	mA
$I_{OL}$	LOW-level output current		-	-	64	mA
$\Delta t/\Delta V$	input transition rise and fall rate		0	-	10	ns/V
$T_{amb}$	ambient temperature	in free air	-40	-	+85	°C



## 9. Static characteristics

Table 6. Static characteristics

Symbol	Parameter	Conditions	25 °C			-40 °C to +85 °C		Unit	
			Min	Typ	Max	Min	Max		
V <sub>IK</sub>	input clamping voltage	V <sub>CC</sub> = 4.5 V; I <sub>IK</sub> = -18 mA	-1.2	-0.9	-	-1.2	-	V	
V <sub>OH</sub>	HIGH-level output voltage	V <sub>I</sub> = V <sub>IL</sub> or V <sub>IH</sub>							
		V <sub>CC</sub> = 4.5 V; I <sub>OH</sub> = -3 mA	2.5	3.0	-	2.5	-	V	
		V <sub>CC</sub> = 5.0 V; I <sub>OH</sub> = -3 mA	3.0	3.5	-	3.0	-	V	
		V <sub>CC</sub> = 4.5 V; I <sub>OH</sub> = -32 mA	2.0	2.4	-	2.0	-	V	
V <sub>OL</sub>	LOW-level output voltage	V <sub>CC</sub> = 4.5 V; I <sub>OL</sub> = 64 mA; V <sub>I</sub> = V <sub>IL</sub> or V <sub>IH</sub>	-	0.3	0.55	-	0.55	V	
V <sub>OL(pu)</sub>	power-up LOW-level output voltage	V <sub>CC</sub> = 5.5 V; I <sub>O</sub> = 1 mA; V <sub>I</sub> = GND or V <sub>CC</sub>	[1]	-	0.13	0.55	-	0.55	V
I <sub>I</sub>	input leakage current	V <sub>CC</sub> = 5.5 V; V <sub>I</sub> = GND or 5.5 V							
		control pins	-	±0.01	±1.0	-	±1.0	μA	
		data pins	-	±5	±100	-	±100	μA	
I <sub>OFF</sub>	power-off leakage current	V <sub>CC</sub> = 0 V; V <sub>I</sub> or V <sub>O</sub> ≤ 4.5 V	-	±5.0	±100	-	±100	μA	
I <sub>O(pu/pd)</sub>	power-up/power-down output current	V <sub>CC</sub> = 2.1 V; V <sub>O</sub> = 0.5 V; V <sub>I</sub> = GND or V <sub>CC</sub> ; OEAB, OEBA don't care	[2]	-	±5.0	±50	-	±50	μA
I <sub>OZ</sub>	OFF-state output current	V <sub>CC</sub> = 5.5 V; V <sub>I</sub> = V <sub>IL</sub> or V <sub>IH</sub>							
		V <sub>O</sub> = 2.7 V	-	5.0	50	-	50	μA	
		V <sub>O</sub> = 0.5 V	-	-5.0	-50	-	-50	μA	
I <sub>LO</sub>	output leakage current	V <sub>CC</sub> = 5.5 V; HIGH-state; V <sub>O</sub> = 5.5 V; V <sub>I</sub> = GND or V <sub>CC</sub>	-	5.0	50	-	50	μA	
I <sub>O</sub>	output current	V <sub>CC</sub> = 5.5 V; V <sub>O</sub> = 2.5 V	[3][5]	-180	-65	-40	-180	-40	mA
I <sub>CC</sub>	supply current	V <sub>CC</sub> = 5.5 V; V <sub>I</sub> = GND or V <sub>CC</sub>							
		outputs HIGH-state	-	110	250	-	250	μA	
		outputs LOW-state	-	20	30	-	30	mA	
		outputs disabled	-	110	250	-	250	μA	
ΔI <sub>CC</sub>	additional supply current	per input pin; V <sub>CC</sub> = 5.5 V; one input at 3.4 V; other inputs at V <sub>CC</sub> or GND	[4]	-	0.3	1.5	-	1.5	mA
C <sub>I</sub>	input capacitance	V <sub>I</sub> = 0 V or V <sub>CC</sub>	-	4	-	-	-	pF	
C <sub>O</sub>	output capacitance	outputs disabled; V <sub>O</sub> = 0 V or V <sub>CC</sub>	-	7	-	-	-	pF	

[1] For valid test results, data must not be loaded into the flip-flops (or latches) after applying the power.

[2] This parameter is valid for any V<sub>CC</sub> between 0 V and 2.1 V with a transition time of up to 10 ms. For V<sub>CC</sub> = 2.1 V to V<sub>CC</sub> = 5 V ± 10 %, a transition time of up to 100 μs is permitted.

[3] Not more than one output should be tested at a time, and the duration of the test should not exceed one second.

[4] This is the increase in supply current for each input at 3.4 V.

[5] This data sheet limit may vary among suppliers.

## 10. Dynamic characteristics

**Table 7. Dynamic characteristics**  
*GND = 0 V; for test circuit, see Figure 12.*

Symbol	Parameter	Conditions	25 °C; V <sub>CC</sub> = 5.0 V			-40 °C to +85 °C; V <sub>CC</sub> = 5.0 V ± 0.5 V		Unit
			Min	Typ	Max	Min	Max	
f <sub>max</sub>	maximum frequency	see <a href="#">Figure 6</a>	125	300	-	125	-	MHz
t <sub>PLH</sub>	LOW to HIGH propagation delay	CPAB to Bn or CPBA to An; see <a href="#">Figure 6</a>	2.2	3.7	5.1	2.2	5.6	ns
		An to Bn or Bn to An; see <a href="#">Figure 7</a>	1.5	3.0	4.3	1.5	4.8	ns
		SAB to Bn or SBA to An; see <a href="#">Figure 8</a>	1.5	3.5	5.1	1.5	6.5	ns
t <sub>PHL</sub>	HIGH to LOW propagation delay	CPAB to Bn or CPBA to An; see <a href="#">Figure 6</a>	1.7	4.3	5.1	1.7	5.6	ns
		An to Bn or Bn to An; see <a href="#">Figure 7</a>	1.5	3.6	4.6	1.5	5.4	ns
		SAB to Bn or SBA to An; see <a href="#">Figure 8</a>	1.5	4.2	5.2 <sup>[1]</sup>	1.5	5.9	ns
t <sub>PZH</sub>	OFF-state to HIGH propagation delay	$\overline{OEBA}$ to An; see <a href="#">Figure 10</a>	2	3.2	4.6	2	5.8	ns
		OEAB to Bn; see <a href="#">Figure 10</a>	2	3.5	6.1	2	6.5	ns
t <sub>PZL</sub>	OFF-state to LOW propagation delay	$\overline{OEBA}$ to An; see <a href="#">Figure 11</a>	3	4.5	6.8	3	8.5	ns
		OEAB to Bn; see <a href="#">Figure 11</a>	3	4.7	6.5	3	7.4	ns
t <sub>PHZ</sub>	HIGH to OFF-state propagation delay	$\overline{OEBA}$ to An; see <a href="#">Figure 10</a>	1.5	3.9	4.7 <sup>[1]</sup>	1.5	5.3 <sup>[1]</sup>	ns
		OEAB to Bn; see <a href="#">Figure 10</a>	1.5	3.8	4.6 <sup>[1]</sup>	1.5	5.5	ns
t <sub>PLZ</sub>	LOW to OFF-state propagation delay	$\overline{OEBA}$ to An; see <a href="#">Figure 11</a>	1.5	2.9	3.8	1.5	4.1	ns
		OEAB to Bn; see <a href="#">Figure 11</a>	1.5	3.0	4.4	1.5	5.1	ns
t <sub>su(H)</sub>	set-up time HIGH	An to CPAB, Bn to CPBA; see <a href="#">Figure 9</a>	3.0	0.7	-	3.0	-	ns
t <sub>su(L)</sub>	set-up time LOW	An to CPAB, Bn to CPBA; see <a href="#">Figure 9</a>	3.0	0.7	-	3.0	-	ns
t <sub>h(H)</sub>	hold time HIGH	An to CPAB, Bn to CPBA; see <a href="#">Figure 9</a>	0.0	-0.5	-	0.0	-	ns
t <sub>h(L)</sub>	hold time LOW	An to CPAB, Bn to CPBA; see <a href="#">Figure 9</a>	0.0	-0.5	-	0.0	-	ns
t <sub>WH</sub>	pulse width HIGH	CPAB, CPBA; see <a href="#">Figure 6</a>	4.0	1.0	-	4.0	-	ns
t <sub>WL</sub>	pulse width LOW	CPAB, CPBA; see <a href="#">Figure 6</a>	4.0	1.0	-	4.0	-	ns

[1] This data sheet limit may vary among suppliers.

11. Waveforms

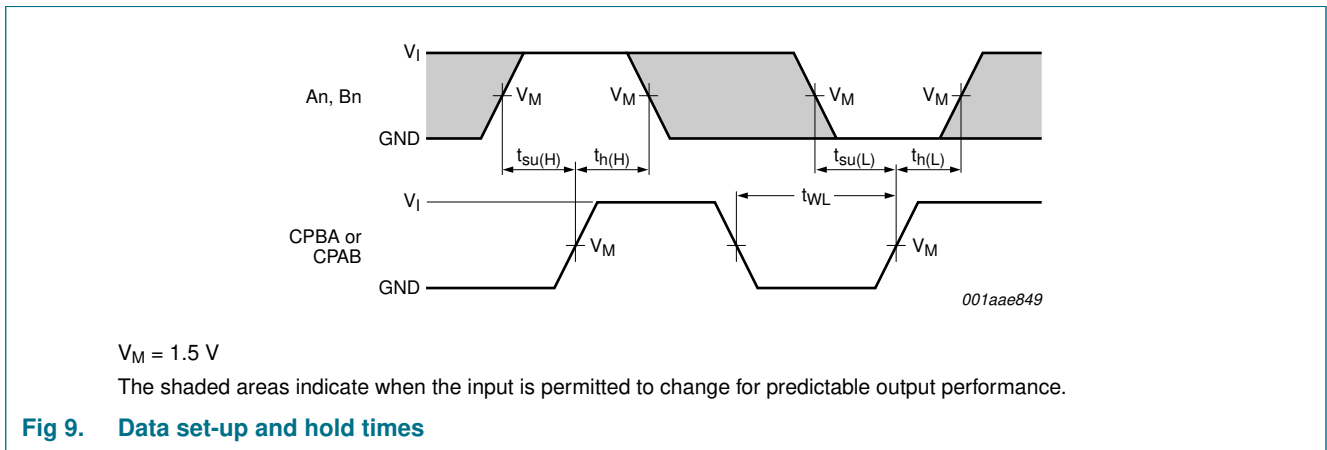
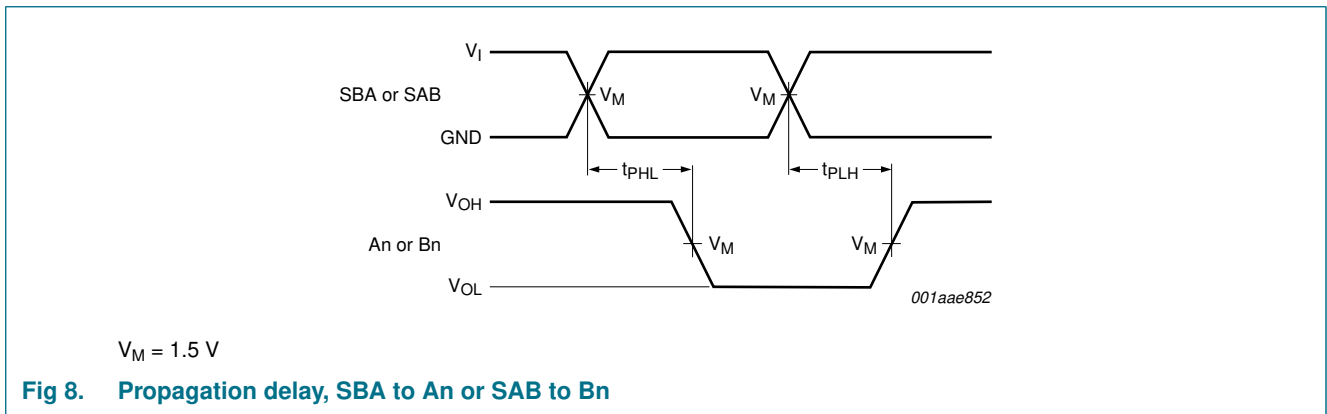
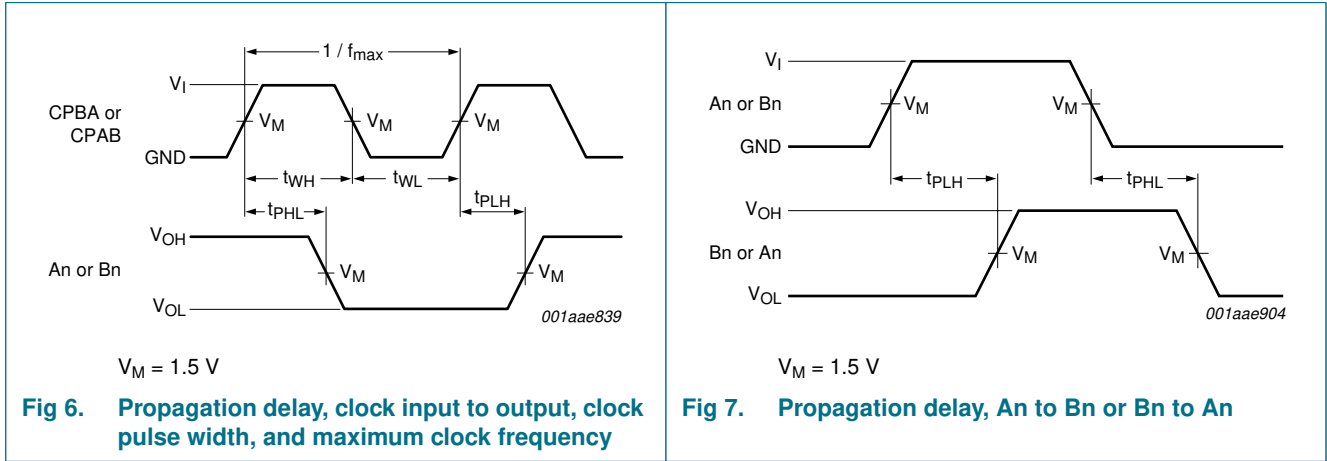

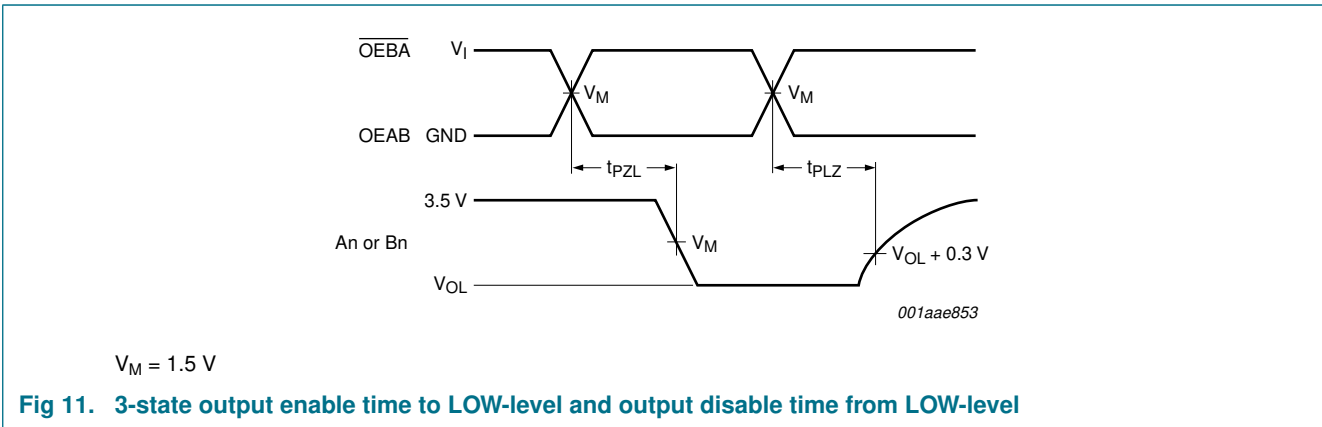
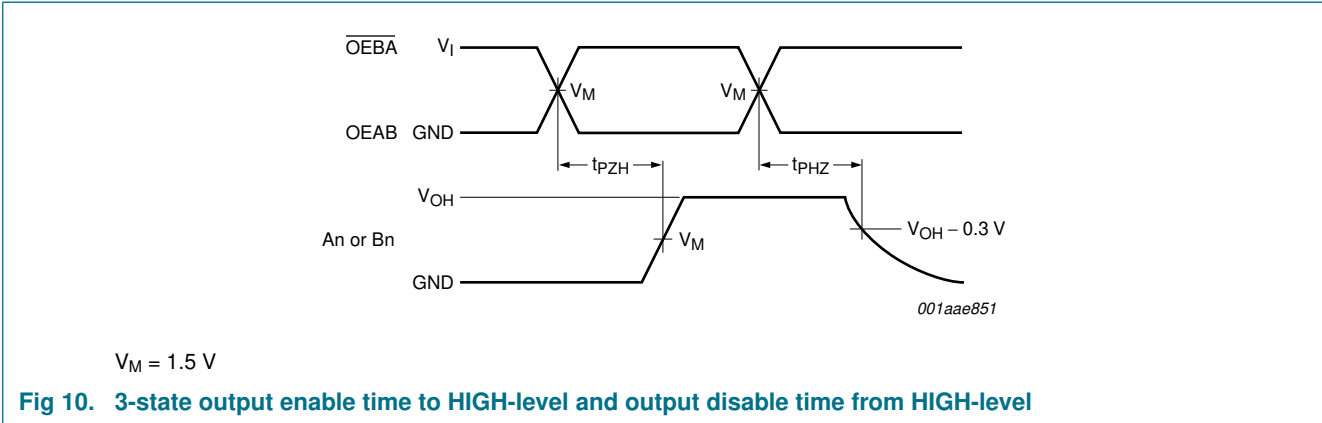

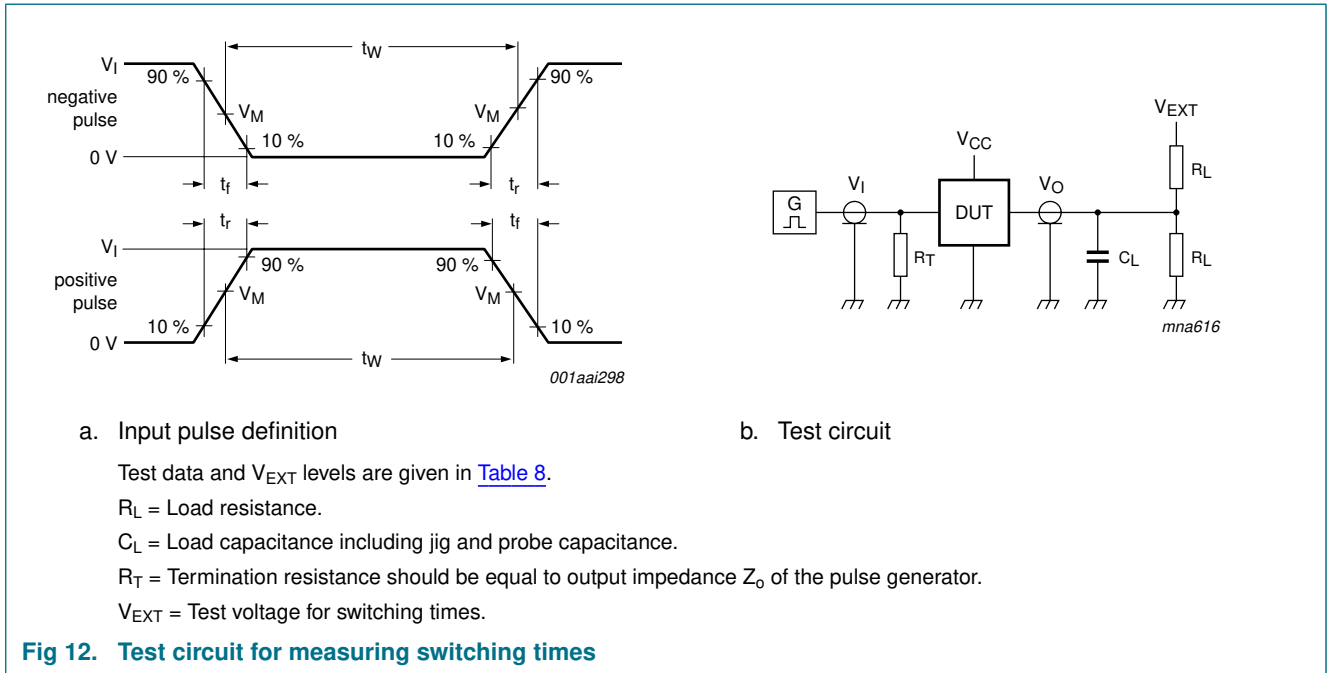

Table 8. Test data

Input				Load		$V_{EXT}$		
$V_I$	$f_I$	$t_w$	$t_r, t_f$	$C_L$	$R_L$	$t_{PHL}, t_{PLH}$	$t_{PZH}, t_{PHZ}$	$t_{PZL}, t_{PLZ}$
3.0 V	1 MHz	500 ns	$\leq 2.5$ ns	50 pF	500 $\Omega$	open	open	7.0 V

12. Package outline

SO24: plastic small outline package; 24 leads; body width 7.5 mm

SOT137-1

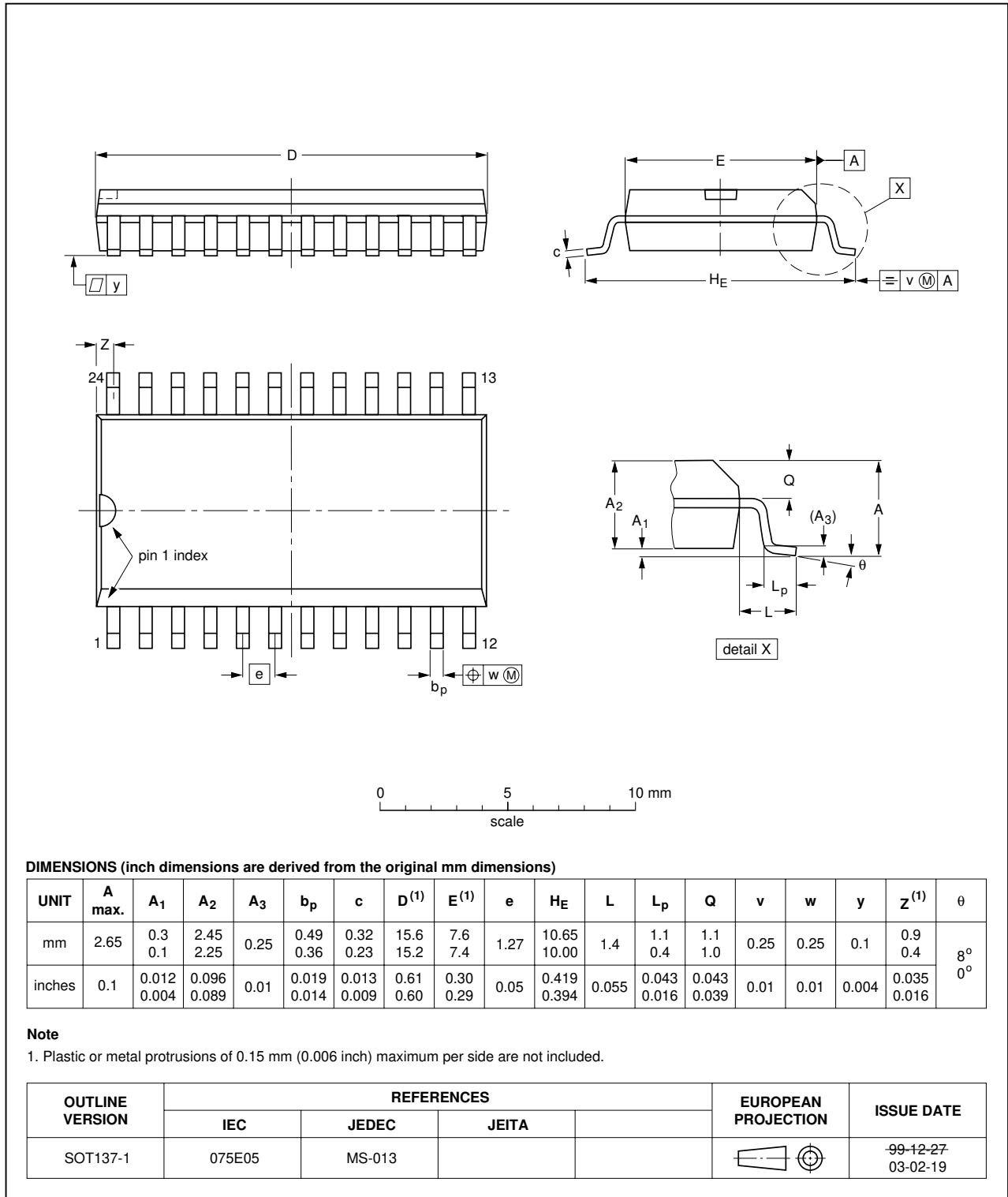

Fig 13. Package outline SOT137-1 (SO24)

SSOP24: plastic shrink small outline package; 24 leads; body width 5.3 mm

SOT340-1

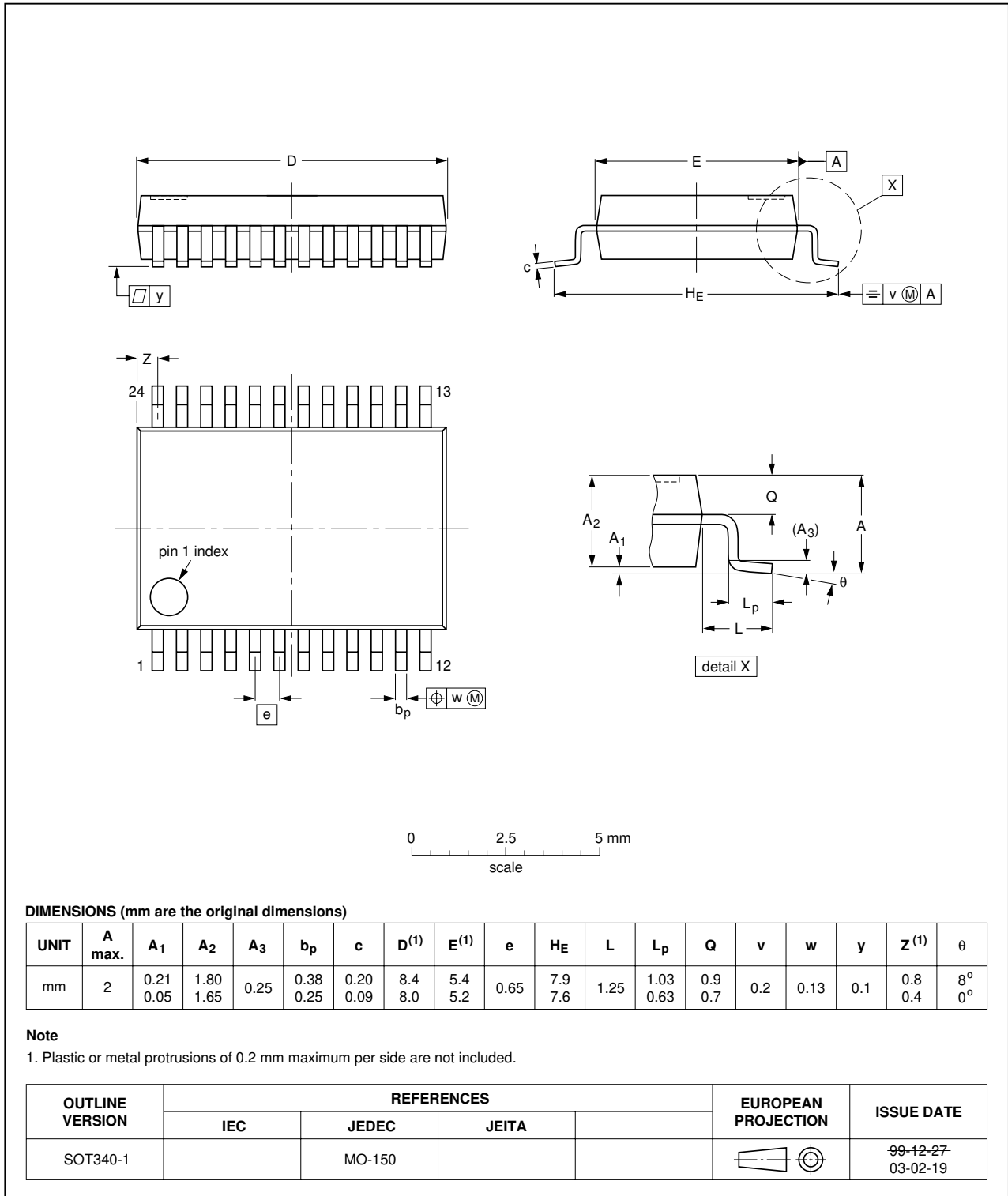

Fig 14. Package outline SOT340-1 (SSOP24)

TSSOP24: plastic thin shrink small outline package; 24 leads; body width 4.4 mm

SOT355-1

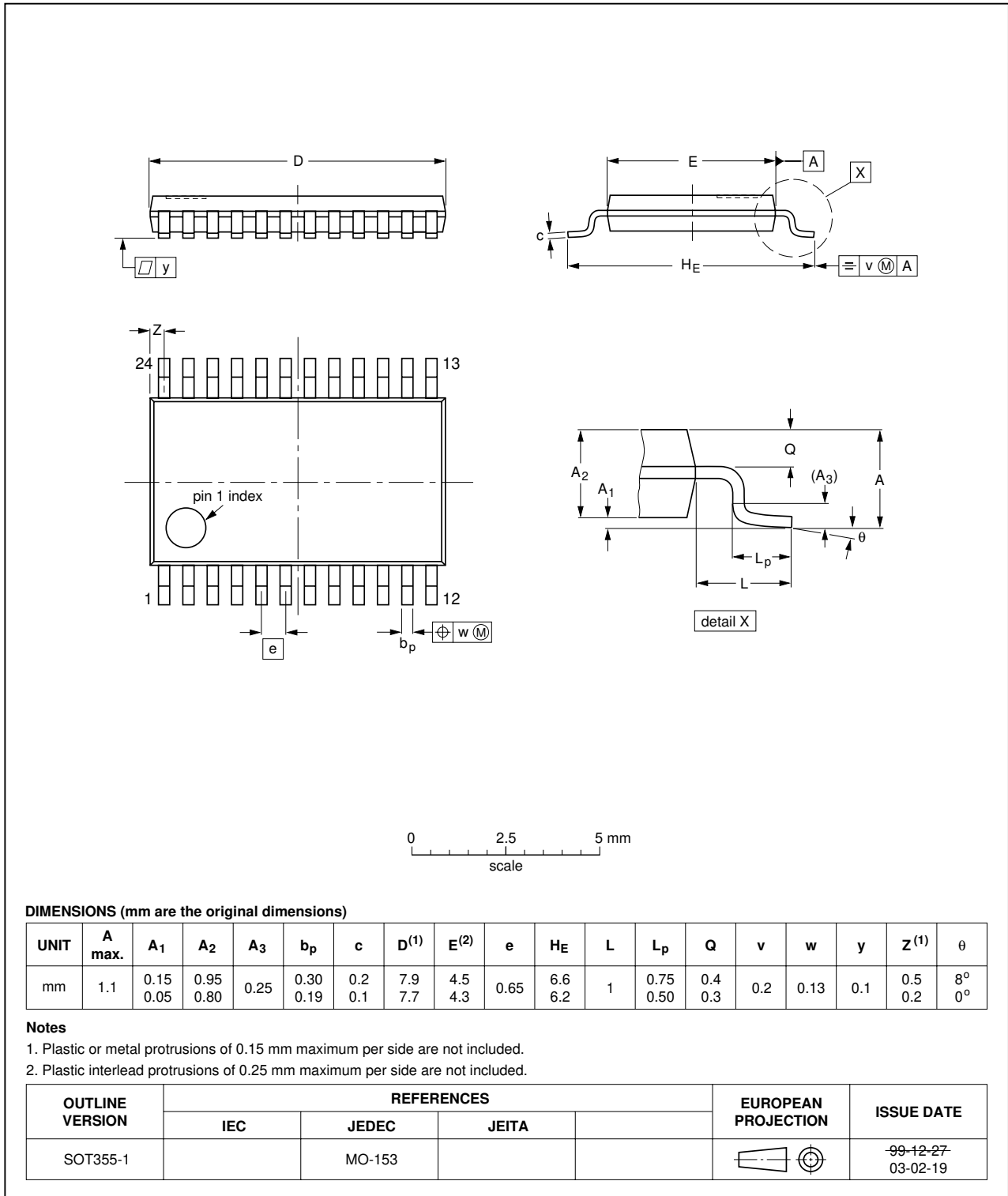

Fig 15. Package outline SOT355-1 (TSSOP24)



## 13. Abbreviations

**Table 9. Abbreviations**

Acronym	Description
BiCMOS	Bipolar Complementary Metal-Oxide Semiconductor
DUT	Device Under Test
ESD	ElectroStatic Discharge
HBM	Human Body Model
MM	Machine Model

## 14. Revision history

**Table 10. Revision history**

Document ID	Release date	Data sheet status	Change notice	Supersedes
74ABT652A_2	20100312	Product data sheet	-	74ABT652A
Modifications:	<ul style="list-style-type: none"> <li>The format of this data sheet has been redesigned to comply with the new identity guidelines of NXP Semiconductors.</li> <li>Legal texts have been adapted to the new company name where appropriate.</li> <li>DIP 24 (SOT222-1) package removed from <a href="#">Section 3 “Ordering information”</a> and <a href="#">Section 12 “Package outline”</a>.</li> </ul>			
74ABT652A	19950419	Product specification	-	-

## 15. Legal information

### 15.1 Data sheet status

Document status <sup>[1][2]</sup>	Product status <sup>[3]</sup>	Definition
Objective [short] data sheet	Development	This document contains data from the objective specification for product development.
Preliminary [short] data sheet	Qualification	This document contains data from the preliminary specification.
Product [short] data sheet	Production	This document contains the product specification.

[1] Please consult the most recently issued document before initiating or completing a design.

[2] The term 'short data sheet' is explained in section "Definitions".

[3] The product status of device(s) described in this document may have changed since this document was published and may differ in case of multiple devices. The latest product status information is available on the Internet at URL <http://www.nxp.com>.

### 15.2 Definitions

**Draft** — The document is a draft version only. The content is still under internal review and subject to formal approval, which may result in modifications or additions. NXP Semiconductors does not give any representations or warranties as to the accuracy or completeness of information included herein and shall have no liability for the consequences of use of such information.

**Short data sheet** — A short data sheet is an extract from a full data sheet with the same product type number(s) and title. A short data sheet is intended for quick reference only and should not be relied upon to contain detailed and full information. For detailed and full information see the relevant full data sheet, which is available on request via the local NXP Semiconductors sales office. In case of any inconsistency or conflict with the short data sheet, the full data sheet shall prevail.

**Product specification** — The information and data provided in a Product data sheet shall define the specification of the product as agreed between NXP Semiconductors and its customer, unless NXP Semiconductors and customer have explicitly agreed otherwise in writing. In no event however, shall an agreement be valid in which the NXP Semiconductors product is deemed to offer functions and qualities beyond those described in the Product data sheet.

### 15.3 Disclaimers

**Limited warranty and liability** — Information in this document is believed to be accurate and reliable. However, NXP Semiconductors does not give any representations or warranties, expressed or implied, as to the accuracy or completeness of such information and shall have no liability for the consequences of use of such information.

In no event shall NXP Semiconductors be liable for any indirect, incidental, punitive, special or consequential damages (including - without limitation - lost profits, lost savings, business interruption, costs related to the removal or replacement of any products or rework charges) whether or not such damages are based on tort (including negligence), warranty, breach of contract or any other legal theory.

Notwithstanding any damages that customer might incur for any reason whatsoever, NXP Semiconductors' aggregate and cumulative liability towards customer for the products described herein shall be limited in accordance with the *Terms and conditions of commercial sale* of NXP Semiconductors.

**Right to make changes** — NXP Semiconductors reserves the right to make changes to information published in this document, including without limitation specifications and product descriptions, at any time and without notice. This document supersedes and replaces all information supplied prior to the publication hereof.

**Suitability for use in automotive applications** — This NXP Semiconductors product has been qualified for use in automotive applications. The product is not designed, authorized or warranted to be

suitable for use in medical, military, aircraft, space or life support equipment, nor in applications where failure or malfunction of an NXP Semiconductors product can reasonably be expected to result in personal injury, death or severe property or environmental damage. NXP Semiconductors accepts no liability for inclusion and/or use of NXP Semiconductors products in such equipment or applications and therefore such inclusion and/or use is at the customer's own risk.

**Applications** — Applications that are described herein for any of these products are for illustrative purposes only. NXP Semiconductors makes no representation or warranty that such applications will be suitable for the specified use without further testing or modification.

NXP Semiconductors does not accept any liability related to any default, damage, costs or problem which is based on a weakness or default in the customer application/use or the application/use of customer's third party customer(s) (hereinafter both referred to as "Application"). It is customer's sole responsibility to check whether the NXP Semiconductors product is suitable and fit for the Application planned. Customer has to do all necessary testing for the Application in order to avoid a default of the Application and the product. NXP Semiconductors does not accept any liability in this respect.

**Limiting values** — Stress above one or more limiting values (as defined in the Absolute Maximum Ratings System of IEC 60134) will cause permanent damage to the device. Limiting values are stress ratings only and (proper) operation of the device at these or any other conditions above those given in the Recommended operating conditions section (if present) or the Characteristics sections of this document is not warranted. Constant or repeated exposure to limiting values will permanently and irreversibly affect the quality and reliability of the device.

**Terms and conditions of commercial sale** — NXP Semiconductors products are sold subject to the general terms and conditions of commercial sale, as published at <http://www.nxp.com/profile/terms>, unless otherwise agreed in a valid written individual agreement. In case an individual agreement is concluded only the terms and conditions of the respective agreement shall apply. NXP Semiconductors hereby expressly objects to applying the customer's general terms and conditions with regard to the purchase of NXP Semiconductors products by customer.

**No offer to sell or license** — Nothing in this document may be interpreted or construed as an offer to sell products that is open for acceptance or the grant, conveyance or implication of any license under any copyrights, patents or other industrial or intellectual property rights.

**Export control** — This document as well as the item(s) described herein may be subject to export control regulations. Export might require a prior authorization from national authorities.

### 15.4 Trademarks

Notice: All referenced brands, product names, service names and trademarks are the property of their respective owners.

## 16. Contact information

---

For more information, please visit: <http://www.nxp.com>

For sales office addresses, please send an email to: [salesaddresses@nxp.com](mailto:salesaddresses@nxp.com)

## 17. Contents

<b>1</b>	<b>General description</b> .....	<b>1</b>
<b>2</b>	<b>Features and benefits</b> .....	<b>1</b>
<b>3</b>	<b>Ordering information</b> .....	<b>1</b>
<b>4</b>	<b>Block diagram</b> .....	<b>2</b>
<b>5</b>	<b>Pinning information</b> .....	<b>5</b>
5.1	Pinning .....	5
5.2	Pin description .....	5
<b>6</b>	<b>Functional description</b> .....	<b>6</b>
6.1	Function table .....	6
<b>7</b>	<b>Limiting values</b> .....	<b>7</b>
<b>8</b>	<b>Recommended operating conditions</b> .....	<b>7</b>
<b>9</b>	<b>Static characteristics</b> .....	<b>8</b>
<b>10</b>	<b>Dynamic characteristics</b> .....	<b>9</b>
<b>11</b>	<b>Waveforms</b> .....	<b>10</b>
<b>12</b>	<b>Package outline</b> .....	<b>13</b>
<b>13</b>	<b>Abbreviations</b> .....	<b>16</b>
<b>14</b>	<b>Revision history</b> .....	<b>16</b>
<b>15</b>	<b>Legal information</b> .....	<b>17</b>
15.1	Data sheet status .....	17
15.2	Definitions .....	17
15.3	Disclaimers .....	17
15.4	Trademarks .....	17
<b>16</b>	<b>Contact information</b> .....	<b>18</b>
<b>17</b>	<b>Contents</b> .....	<b>19</b>

Please be aware that important notices concerning this document and the product(s) described herein, have been included in section 'Legal information'.

© NXP B.V. 2010.

All rights reserved.

For more information, please visit: <http://www.nxp.com>

For sales office addresses, please send an email to: [salesaddresses@nxp.com](mailto:salesaddresses@nxp.com)

Date of release: 12 March 2010

Document identifier: 74ABT652A\_2