



Chipsmall Limited consists of a professional team with an average of over 10 year of expertise in the distribution of electronic components. Based in Hongkong, we have already established firm and mutual-benefit business relationships with customers from,Europe,America and south Asia,supplying obsolete and hard-to-find components to meet their specific needs.

With the principle of “Quality Parts,Customers Priority,Honest Operation,and Considerate Service”,our business mainly focus on the distribution of electronic components. Line cards we deal with include Microchip,ALPS,ROHM,Xilinx,Pulse,ON,Everlight and Freescale. Main products comprise IC,Modules,Potentiometer,IC Socket,Relay,Connector.Our parts cover such applications as commercial,industrial, and automotives areas.

We are looking forward to setting up business relationship with you and hope to provide you with the best service and solution. Let us make a better world for our industry!



Contact us

Tel: +86-755-8981 8866 Fax: +86-755-8427 6832

Email & Skype: info@chipsmall.com Web: www.chipsmall.com

Address: A1208, Overseas Decoration Building, #122 Zhenhua RD., Futian, Shenzhen, China



74ABT652

Octal Transceivers and Registers with 3-STATE Outputs

General Description

The ABT652 consists of bus transceiver circuits with D-type flip-flops and control circuitry arranged for multiplexed transmission of data directly from the input bus or from the internal registers. Data on the A or B bus will be clocked into the registers as the appropriate clock pin goes to HIGH logic level. Output Enable pins (\overline{OEAB} , \overline{OEBA}) are provided to control the transceiver function.

Features

- Independent registers for A and B buses
- Multiplexed real-time and stored data

- A and B output sink capability of 64 mA, source capability of 32 mA
- Guaranteed output skew
- Guaranteed multiple output switching specifications
- Output switching specified for both 50 pF and 250 pF loads
- Guaranteed simultaneous switching noise level and dynamic threshold performance
- Guaranteed latchup protection
- High impedance glitch free bus loading during entire power up and power down cycle
- Nondestructive hot insertion capability

Ordering Code:

Order Number	Package Number	Package Description
74ABT652CSC	M24B	24-Lead Small Outline Integrated Circuit (SOIC), JEDEC MS-013, 0.300" Wide Body
74ABT652CMSA	MSA24	24-Lead Shrink Small Outline Package (SSOP), EIAJ TYPE II, 5.3mm Wide
74ABT652CMTC	MTC24	24-Lead Thin Shrink Small Outline Package (TSSOP), JEDEC MO-153, 4.4mm Wide

Devices also available in Tape and Reel. Specify by appending the suffix letter "X" to the ordering code.

Connection Diagram

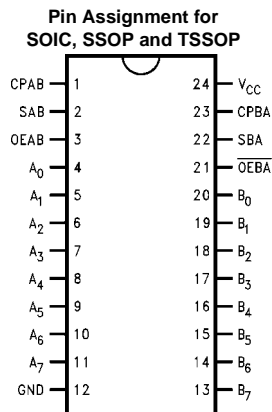

Pin Descriptions

Pin Names	Description
A ₀ -A ₇	Data Register A Inputs/3-STATE Outputs
B ₀ -B ₇	Data Register B Inputs/3-STATE Outputs
CPAB, CPBA	Clock Pulse Inputs
SAB, SBA	Select Inputs
OEAB, \overline{OEBA}	Output Enable Inputs

Truth Table

Inputs						Inputs/Outputs (Note 1)		Operating Mode
OEAB	OEBA	CPAB	CPBA	SAB	SBA	A ₀ thru A ₇	B ₀ thru B ₇	
L	H	H or L	H or L	X	X	Input	Input	Isolation
L	H	↗	↗	X	X			Store A and B Data
X	H	↗	H or L	X	X	Input	Not Specified	Store A, Hold B
H	H	↗	↗	X	X	Input	Output	Store A in Both Registers
L	X	H or L	↗	X	X	Not Specified	Input	Hold A, Store B
L	L	↗	↗	X	X	Output	Input	Store B in Both Registers
L	L	X	X	X	L	Output	Input	Real-Time B Data to A Bus
L	L	X	H or L	X	H			Store B Data to A Bus
H	H	X	X	L	X	Input	Output	Real-Time A Data to B Bus
H	H	H or L	X	H	X			Stored A Data to B Bus
H	L	H or L	H or L	H	H	Output	Output	Stored A Data to B Bus and Stored B Data to A Bus

H = HIGH Voltage Level
 L = LOW Voltage Level
 X = Immaterial
 ↗ = LOW to HIGH Clock Transition

Note 1: The data output functions may be enabled or disabled by various signals at OEAB or OEBA inputs. Data input functions are always enabled, i.e., data at the bus pins will be stored on every LOW to HIGH transition on the clock inputs.

Functional Description

In the transceiver mode, data present at the HIGH impedance port may be stored in either the A or B register or both.

The select (SAB, SBA) controls can multiplex stored and real-time.

The examples in Figure 1 demonstrate the four fundamental bus-management functions that can be performed with the ABT652.

Data on the A or B data bus, or both, can be stored in the internal D flip-flop by LOW to HIGH transitions at the appropriate Clock Inputs (CPAB, CPBA) regardless of the Select or Output Enable Inputs. When SAB and SBA are in the real time transfer mode, it is also possible to store data without using the internal D flip-flops by simultaneously enabling OEAB and OEBA. In this configuration each Output reinforces its Input. Thus when all other data sources to the two sets of bus lines are in a HIGH impedance state, each set of bus lines will remain at its last state.

Logic Diagram

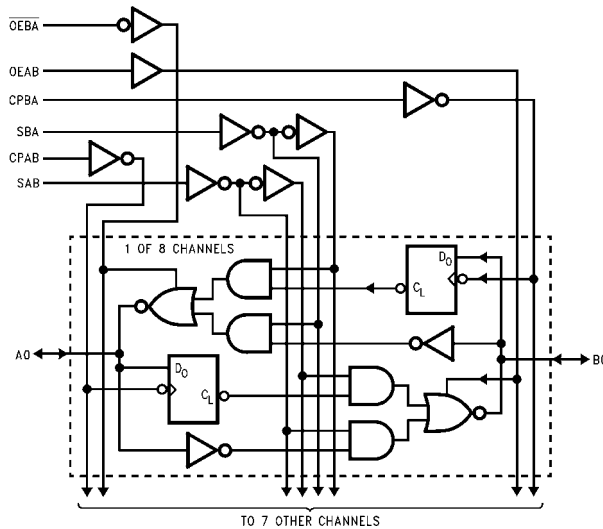

Please note that this diagram is provided only for the understanding of logic operations and should not be used to estimate propagation delays.

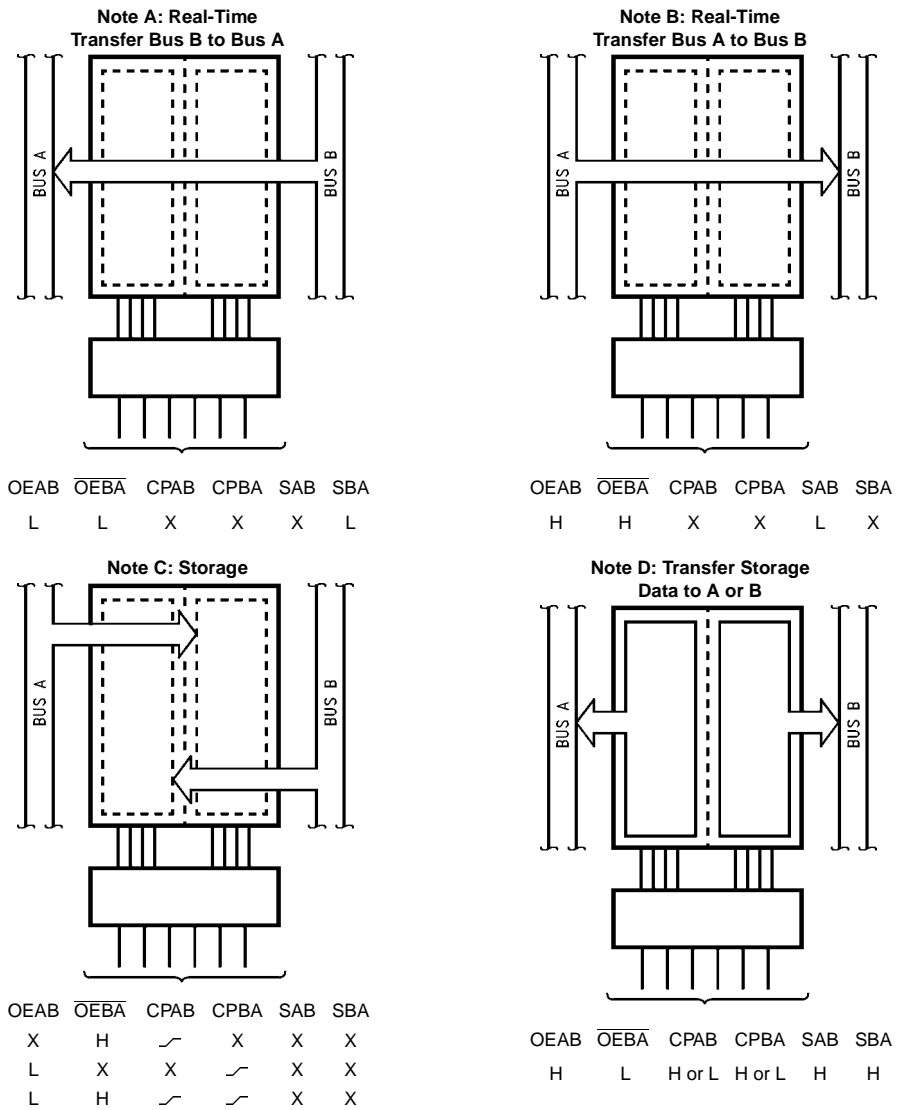

FIGURE 1.

Absolute Maximum Ratings (Note 2)		Over Voltage Latchup (I/O)	10V
Storage Temperature	-65°C to +150°C	Recommended Operating Conditions	Free Air Ambient Temperature -40°C to +85°C Supply Voltage +4.5V to +5.5V Minimum Input Edge Rate ($\Delta V/\Delta t$) Data Input 50 mV/ns Enable Input 20 mV/ns Clock Input 100 mV/ns
Ambient Temperature under Bias	-55°C to +125°C		
Junction Temperature under Bias	-55°C to +150°C		
V _{CC} Pin Potential to Ground Pin	-0.5V to +7.0V		
Input Voltage (Note 3)	-0.5V to +7.0V		
Input Current (Note 3)	-30 mA to +5.0 mA		
Voltage Applied to Any Output in the Disable or Power-Off State in the HIGH State	-0.5V to +5.5V -0.5V to V _{CC}		
Current Applied to Output in LOW State (Max)	twice the rated I _{OL} (mA)		
DC Latchup Source Current	-500 mA		

DC Electrical Characteristics

Symbol	Parameter	Min	Typ	Max	Units	V _{CC}	Conditions
V _{IH}	Input HIGH Voltage	2.0			V		Recognized HIGH Signal
V _{IL}	Input LOW Voltage			0.8	V		Recognized LOW Signal
V _{CD}	Input Clamp Diode Voltage			-1.2	V	Min	I _{IN} = -18 mA (Non I/O Pins)
V _{OH}	Output HIGH Voltage	2.5			V	Min	I _{OH} = -3 mA, (A _n , B _n) I _{OH} = -32 mA, (A _n , B _n)
V _{OL}	Output LOW Voltage			0.55	V	Min	I _{OL} = 64 mA, (A _n , B _n)
V _{ID}	Input Leakage Test	4.75			V	0.0	I _{ID} = 1.9 μA, (Non-I/O Pins) All Other Pins Grounded
I _{IH}	Input HIGH Current			1	μA	Max	V _{IN} = 2.7V (Non-I/O Pins) (Note 4) V _{IN} = V _{CC} (Non-I/O Pins)
I _{BVI}	Input HIGH Current Breakdown Test			7	μA	Max	V _{IN} = 7.0V (Non-I/O Pins)
I _{BVIT}	Input HIGH Current Breakdown Test (I/O)			100	μA	Max	V _{IN} = 5.5V (A _n , B _n)
I _{IL}	Input LOW Current			-1	μA	Max	V _{IN} = 0.5V (Non-I/O Pins) (Note 4) V _{IN} = 0.0V (Non-I/O Pins)
I _{IH} + I _{OZH}	Output Leakage Current			10	μA	0V-5.5V	V _{OUT} = 2.7V (A _n , B _n); OE \bar{B} A = 2.0V and OEAB = GND = 2.0V
I _{IL} + I _{OZL}	Output Leakage Current			-10	μA	0V-5.5V	V _{OUT} = 0.5V (A _n , B _n); OE \bar{B} A = 2.0V and OEAB = GND = 2.0V
I _{OS}	Output Short-Circuit Current	-100		-275	mA	Max	V _{OUT} = 0V (A _n , B _n)
I _{CEX}	Output HIGH Leakage Current			50	μA	Max	V _{OUT} = V _{CC} (A _n , B _n)
I _{ZZ}	Bus Drainage Test			100	μA	0.0V	V _{OUT} = 5.5V (A _n , B _n); All Others GND
I _{CCH}	Power Supply Current			250	μA	Max	All Outputs HIGH
I _{CCL}	Power Supply Current			30	mA	Max	All Outputs LOW
I _{CCZ}	Power Supply Current			50	μA	Max	Outputs 3-STATE; All others at V _{CC} or GND
I _{CCT}	Additional I _{CC} /Input			2.5	mA	Max	V _I = V _{CC} - 2.1V All others at V _{CC} or GND
I _{CCD}	Dynamic I _{CC} (Note 6)			0.18	mA/MHz	Max	Outputs Open (Note 5) OEAB = OE \bar{B} A = GND One bit toggling, 50% duty cycle

Note 4: Guaranteed but not tested.

Note 5: For 8 outputs toggling, I_{CCD} < 1.4 mA/MHz.

Note 6: Guaranteed, but not tested.

DC Electrical Characteristics

(SOIC package)

Symbol	Parameter	Min	Typ	Max	Units	V _{CC}	Conditions C _L = 50 pF, R _L = 500Ω
V _{OLP}	Quiet Output Maximum Dynamic V _{OL}		0.6	0.8	V	5.0	T _A = 25°C (Note 7)
V _{OLV}	Quiet Output Minimum Dynamic V _{OL}	-1.2	-0.9		V	5.0	T _A = 25°C (Note 7)
V _{OHV}	Minimum HIGH Level Dynamic Output Voltage	2.5	3.0		V	5.0	T _A = 25°C (Note 8)
V _{IHD}	Minimum HIGH Level Dynamic Input Voltage	2.2	1.8		V	5.0	T _A = 25°C (Note 9)
V _{ILD}	Maximum LOW Level Dynamic Input Voltage		0.8	0.4	V	5.0	T _A = 25°C (Note 9)

Note 7: Max number of outputs defined as (n). n – 1 data inputs are driven 0V to 3V. One output at LOW. Guaranteed, but not tested.

Note 8: Max number of outputs defined as (n). n – 1 data inputs are driven 0V to 3V. One output HIGH. Guaranteed, but not tested.

Note 9: Max number of data inputs (n) switching. n – 1 inputs switching 0V to 3V. Input-under-test switching: 3V to threshold (V_{ILD}), 0V to threshold (V_{IHD}). Guaranteed, but not tested.

AC Electrical Characteristics

(SOIC and SSOP Package)

Symbol	Parameter	T _A = +25°C V _{CC} = +5.0V C _L = 50 pF			T _A = -40°C to +85°C V _{CC} = 4.5V–5.5V C _L = 50 pF		Units
		Min	Typ	Max	Min	Max	
f _{max}	Max Clock Frequency	200			200		MHz
t _{PLH}	Propagation Delay	1.7	3.0	4.9	1.7	4.9	ns
t _{PHL}	Clock to Bus	1.7	3.4	4.9	1.7	4.9	ns
t _{PLH}	Propagation Delay	1.5	2.6	4.5	1.5	4.5	ns
t _{PHL}	Bus to Bus	1.5	3.0	4.5	1.5	4.5	ns
t _{PLH}	Propagation Delay	1.5	3.0	5.0	1.5	5.0	ns
t _{PHL}	SBA or SAB to A _n to B _n	1.5	3.4	5.0	1.5	5.0	ns
t _{PZH}	Enable Time	1.5	3.3	5.5	1.5	5.5	ns
t _{PZL}	OEBA or OEAB to A _n or B _n	1.5	3.7	5.5	1.5	5.5	ns
t _{PHZ}	Disable Time	1.5	3.7	6.0	1.5	6.0	ns
t _{PLZ}	OEBA or OEAB to A _n or B _n	1.5	3.3	6.0	1.5	6.0	ns

AC Operating Requirements								
Symbol	Parameter	$T_A = +25^\circ\text{C}$ $V_{CC} = +5.0\text{V}$ $C_L = 50\text{ pF}$		$T_A = -40^\circ\text{C to } +85^\circ\text{C}$ $V_{CC} = 4.5\text{V} - 5.5\text{V}$ $C_L = 50\text{ pF}$		Units		
		Min	Max	Min	Max			
$t_S(\text{H})$ $t_S(\text{L})$	Setup Time, HIGH or LOW Bus to Clock	1.5		1.5		ns		
$t_H(\text{H})$ $t_H(\text{L})$	Hold Time, HIGH or LOW Bus to Clock	1.0		1.0		ns		
$t_W(\text{H})$ $t_W(\text{L})$	Pulse Width, HIGH or LOW	3.0		3.0		ns		
Extended AC Electrical Characteristics								
(SOIC package):								
Symbol	Parameter	$T_A = -40^\circ\text{C to } +85^\circ\text{C}$ $V_{CC} = 4.5\text{V} - 5.5\text{V}$ $C_L = 50\text{ pF}$ 8 Outputs Switching (Note 10)		$T_A = -40^\circ\text{C to } +85^\circ\text{C}$ $V_{CC} = 4.5\text{V} - 5.5\text{V}$ $C_L = 250\text{ pF}$ 1 Output Switching (Note 11)		$T_A = -40^\circ\text{C to } +85^\circ\text{C}$ $V_{CC} = 4.5\text{V} - 5.5\text{V}$ $C_L = 250\text{ pF}$ 8 Outputs Switching (Note 12)		Units
		Min	Max	Min	Max	Min	Max	
t_{PLH} t_{PHL}	Propagation Delay Clock to Bus	1.5	5.5	2.0	7.5	2.5	10.0	ns
t_{PLH} t_{PHL}	Propagation Delay Bus to Bus	1.5	6.0	2.0	7.0	2.5	9.5	ns
t_{PLH} t_{PHL}	Propagation Delay SBA or SAB to A_n or B_n	1.5	6.0	2.0	7.5	2.5	10.0	ns
t_{PZH} t_{PZL}	Output Enable Time $\overline{\text{OEBA}}$ or OEAB to A_n or B_n	1.5	6.0	2.0	8.0	2.5	11.5	ns
t_{PHZ} t_{PLZ}	Output Disable Time $\overline{\text{OEBA}}$ or OEAB to A_n or B_n	1.5	6.0	(Note 13)		(Note 13)		ns
<p>Note 10: This specification is guaranteed but not tested. The limits apply to propagation delays for all paths described switching in phase (i.e., all LOW-to-HIGH, HIGH-to-LOW, etc.).</p> <p>Note 11: This specification is guaranteed but not tested. The limits represent propagation delay with 250 pF load capacitors in place of the 50 pF load capacitors in the standard AC load. This specification pertains to single output switching only.</p> <p>Note 12: This specification is guaranteed but not tested. The limits represent propagation delays for all paths described switching in phase (i.e., all LOW-to-HIGH, HIGH-to-LOW, etc.) with 250 pF load capacitors in place of the 50 pF load capacitors in the standard AC load.</p> <p>Note 13: The 3-STATE delay times are dominated by the RC network (500Ω, 250 pF) on the output and has been excluded from the datasheet.</p>								

Skew				
(SOIC Package)				
Symbol	Parameter	$T_A = -40^\circ\text{C to } +85^\circ\text{C}$	$T_A = -40^\circ\text{C to } +85^\circ\text{C}$	Units
		$V_{CC} = 4.5\text{V} - 5.5\text{V}$ $C_L = 50\text{ pF}$ 8 Outputs Switching (Note 16)	$V_{CC} = 4.5\text{V} - 5.5\text{V}$ $C_L = 250\text{ pF}$ 8 Outputs Switching (Note 17)	
		Max	Max	
t_{OSHL} (Note 14)	Pin to Pin Skew HL Transitions	1.3	2.5	ns
t_{OSLH} (Note 14)	Pin to Pin Skew LH Transitions	1.0	2.0	ns
t_{PS} (Note 18)	Duty Cycle LH-HL Skew	2.0	4.0	ns
t_{OST} (Note 14)	Pin to Pin Skew LH/HL Transitions	2.0	4.0	ns
t_{PV} (Note 15)	Device to Device Skew LH/HL Transitions	2.5	4.5	ns
<p>Note 14: Skew is defined as the absolute value of the difference between the actual propagation delays for any two separate outputs of the same device. The specification applies to any outputs switching HIGH to LOW (t_{OSHL}), LOW-to-HIGH (t_{OSLH}), or any combination switching LOW-to-HIGH and/or HIGH-to-LOW (t_{OST}). This specification is guaranteed but not tested.</p> <p>Note 15: Propagation delay variation for a given set of conditions (i.e., temperature and V_{CC}) from device to device. This specification is guaranteed but not tested.</p> <p>Note 16: This specification is guaranteed but not tested. The limits apply to propagation delays for all paths described switching in phase (i.e., all LOW-to-HIGH, HIGH-to-LOW, etc.).</p> <p>Note 17: This specification is guaranteed but not tested. The limits represent propagation delays with 250 pF load capacitors in place of the 50 pF load capacitors in the standard AC load.</p> <p>Note 18: This describes the difference between the delay of the LOW-to-HIGH and the HIGH-to-LOW transition on the same pin. It is measured across all the outputs (drivers) on the same chip, the worst (largest delta) number is the guaranteed specification. This specification is guaranteed but not tested.</p>				
Capacitance				
Symbol	Parameter	Typ	Units	Conditions ($T_A = 25^\circ\text{C}$)
C_{IN}	Input Capacitance	5.0	pF	$V_{CC} = 0\text{V}$ (non I/O pins)
$C_{\text{I/O}}$ (Note 19)	I/O Capacitance	11.0	pF	$V_{CC} = 5.0\text{V}$ (A_n, B_n)
<p>Note 19: $C_{\text{I/O}}$ is measured at frequency, $f = 1\text{ MHz}$, per MIL-STD-883D, Method 3012.</p>				

AC Loading

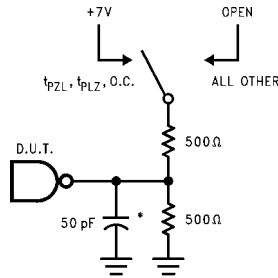

*Includes jig and probe capacitance

FIGURE 2. Standard AC Test Load

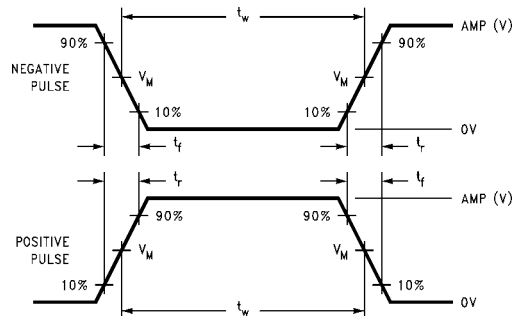

FIGURE 3. Test Input Signal Levels

Input Pulse Requirements

Amplitude	Rep. Rate	t_w	t_r	t_f
3.0V	1 MHz	500 ns	2.5 ns	2.5 ns

FIGURE 4. Test Input Signal Requirements

AC Waveforms

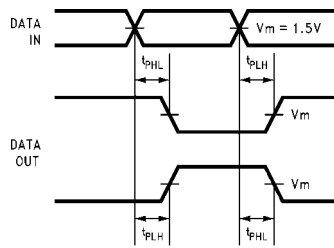

FIGURE 5. Propagation Delay Waveforms for Inverting and Non-Inverting Functions

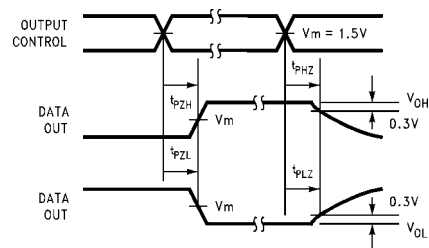

FIGURE 7. 3-STATE Output HIGH and LOW Enable and Disable Times

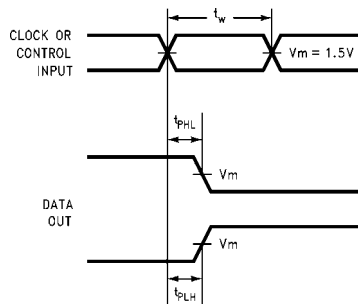

FIGURE 6. Propagation Delay, Pulse Width Waveforms

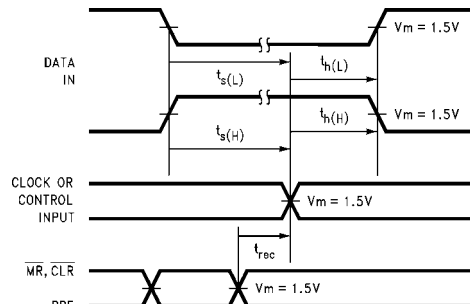
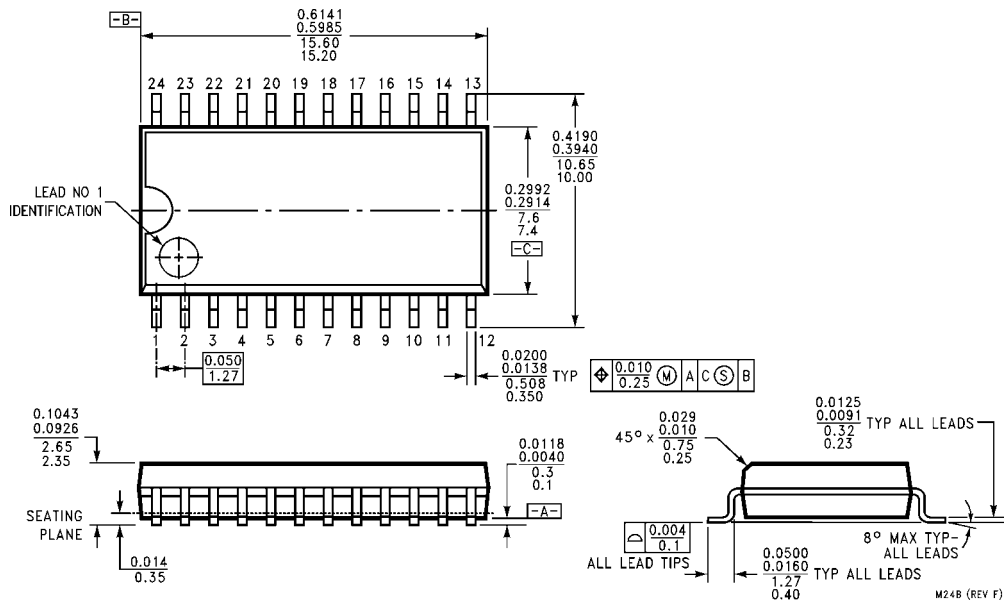
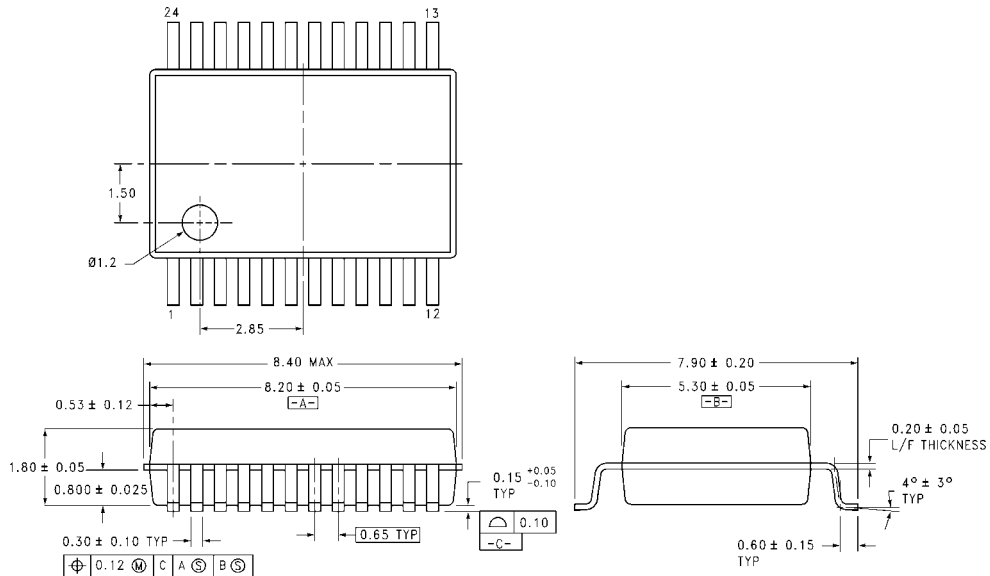

FIGURE 8. Setup Time, Hold Time and Recovery Time Waveforms

Physical Dimensions inches (millimeters) unless otherwise noted



24-Lead Small Outline Integrated Circuit (SOIC), JEDEC MS-013, 0.300" Wide Body Package Number M24B



24-Lead Shrink Small Outline Package (SSOP), EIAJ TYPE II, 5.3mm Wide Package Number MSA24

Physical Dimensions inches (millimeters) unless otherwise noted (Continued)

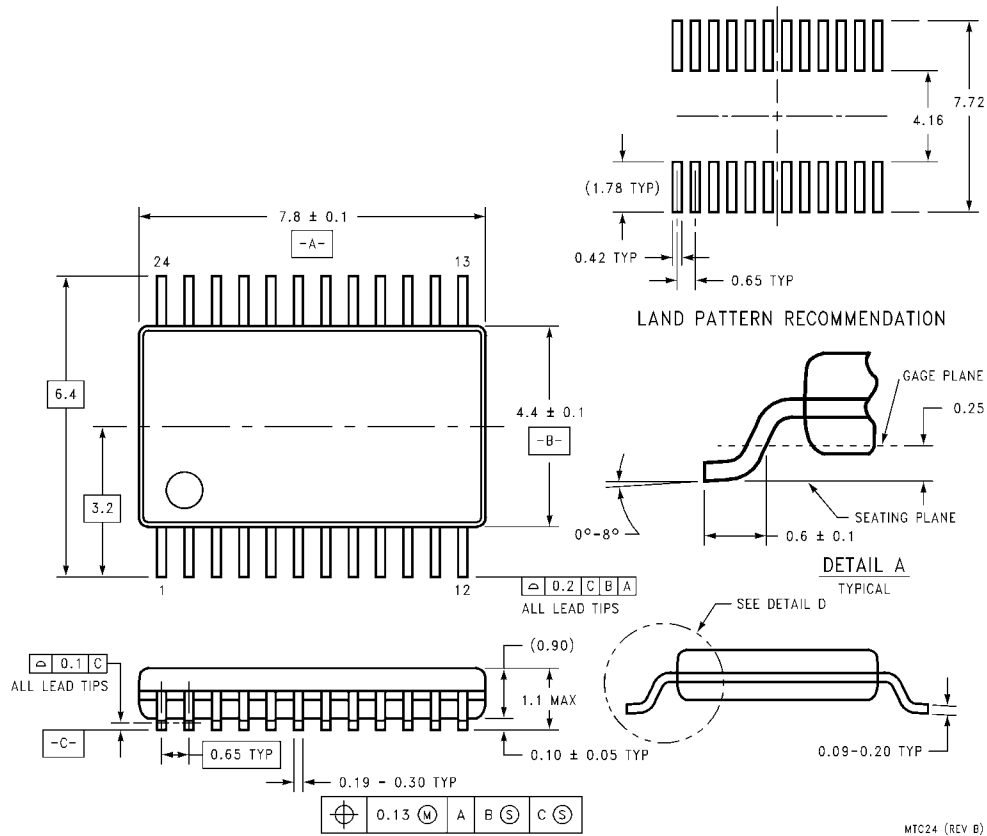

**24-Lead Thin Shrink Small Outline Package (TSSOP), JEDEC MO-153, 4.4mm Wide
Package Number MTC24**

LIFE SUPPORT POLICY

FAIRCHILD'S PRODUCTS ARE NOT AUTHORIZED FOR USE AS CRITICAL COMPONENTS IN LIFE SUPPORT DEVICES OR SYSTEMS WITHOUT THE EXPRESS WRITTEN APPROVAL OF THE PRESIDENT OF FAIRCHILD SEMICONDUCTOR CORPORATION. As used herein:

1. Life support devices or systems are devices or systems which, (a) are intended for surgical implant into the body, or (b) support or sustain life, and (c) whose failure to perform when properly used in accordance with instructions for use provided in the labeling, can be reasonably expected to result in a significant injury to the user.
2. A critical component in any component of a life support device or system whose failure to perform can be reasonably expected to cause the failure of the life support device or system, or to affect its safety or effectiveness.

www.fairchildsemi.com