



Chipsmall Limited consists of a professional team with an average of over 10 year of expertise in the distribution of electronic components. Based in Hongkong, we have already established firm and mutual-benefit business relationships with customers from,Europe,America and south Asia,supplying obsolete and hard-to-find components to meet their specific needs.

With the principle of “Quality Parts,Customers Priority,Honest Operation,and Considerate Service”,our business mainly focus on the distribution of electronic components. Line cards we deal with include Microchip,ALPS,ROHM,Xilinx,Pulse,ON,Everlight and Freescale. Main products comprise IC,Modules,Potentiometer,IC Socket,Relay,Connector.Our parts cover such applications as commercial,industrial, and automotives areas.

We are looking forward to setting up business relationship with you and hope to provide you with the best service and solution. Let us make a better world for our industry!



Contact us

Tel: +86-755-8981 8866 Fax: +86-755-8427 6832

Email & Skype: info@chipsmall.com Web: www.chipsmall.com

Address: A1208, Overseas Decoration Building, #122 Zhenhua RD., Futian, Shenzhen, China





74ACT244

OCTAL BUS BUFFER WITH 3 STATE OUTPUTS (NON INVERTED)

- HIGH SPEED: $t_{PD} = 4.6 \text{ ns}$ (TYP.) at $V_{CC} = 5V$
- LOW POWER DISSIPATION:
 $I_{CC} = 4 \mu\text{A}$ (MAX.) at $T_A=25^\circ\text{C}$
- COMPATIBLE WITH TTL OUTPUTS
 $V_{IH} = 2V$ (MIN.), $V_{IL} = 0.8V$ (MAX.)
- 50Ω TRANSMISSION LINE DRIVING CAPABILITY
- SYMMETRICAL OUTPUT IMPEDANCE:
 $|I_{OH}| = I_{OL} = 24\text{mA}$ (MIN)
- BALANCED PROPAGATION DELAYS:
 $t_{PLH} \approx t_{PHL}$
- OPERATING VOLTAGE RANGE:
 V_{CC} (OPR) = 4.5V to 5.5V
- PIN AND FUNCTION COMPATIBLE WITH 74 SERIES 244
- IMPROVED LATCH-UP IMMUNITY

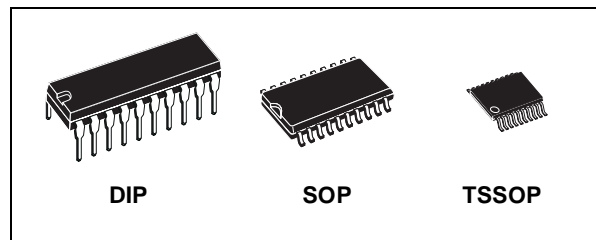

ORDER CODES

| PACKAGE | TUBE | T & R |
|---------|-----------|-------------|
| DIP | 74ACT244B | |
| SOP | 74ACT244M | 74ACT244MTR |
| TSSOP | | 74ACT244TTR |

DESCRIPTION

The 74ACT244 is an advanced high-speed CMOS OCTAL BUS BUFFER (3-STATE) fabricated with sub-micron silicon gate and double-layer metal wiring C²MOS technology. The \bar{G} input controls four BUS BUFFERS. This device is designed to be used with 3 state

memory address drivers, etc.

The device is designed to interface directly High Speed CMOS systems with TTL, NMOS and CMOS output voltage levels.

All inputs and outputs are equipped with protection circuits against static discharge, giving them 2KV ESD immunity and transient excess voltage.

PIN CONNECTION AND IEC LOGIC SYMBOLS

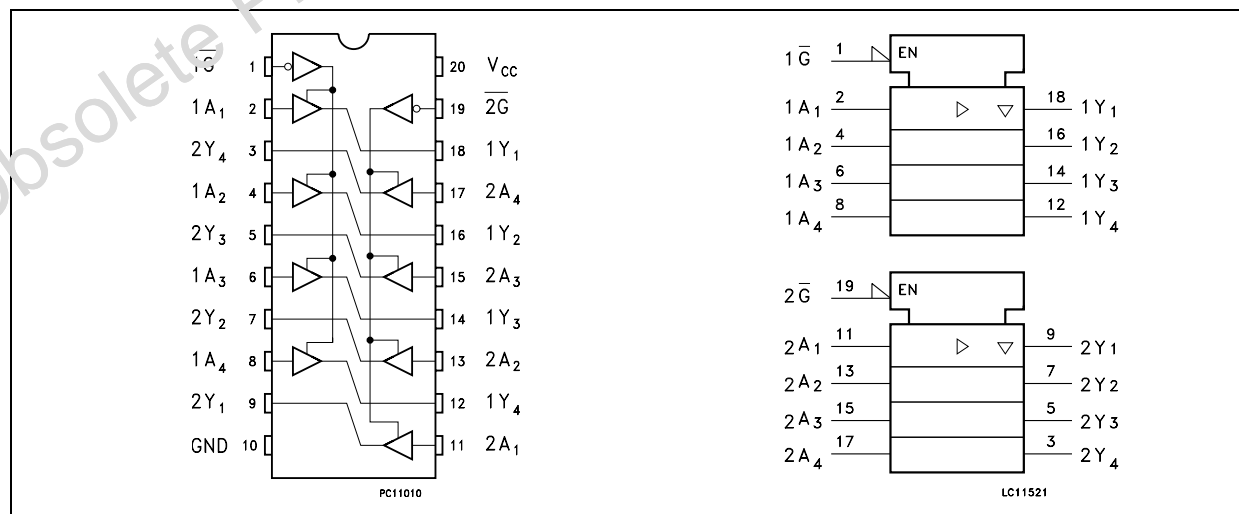

74ACT244

INPUT AND OUTPUT EQUIVALENT CIRCUIT

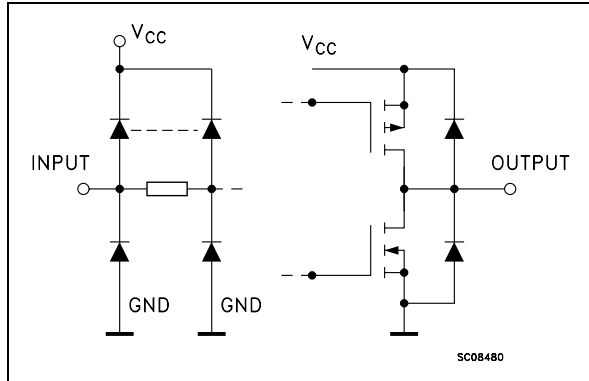

PIN DESCRIPTION

| PIN No | SYMBOL | NAME AND FUNCTION |
|----------------|-----------------|-------------------------|
| 1 | $\overline{1G}$ | Output Enable Input |
| 2, 4, 6, 8 | 1A1 to 1A4 | Data Inputs |
| 9, 7, 5, 3 | 2Y1 to 2Y4 | Data Outputs |
| 11, 13, 15, 17 | 2A1 to 2A4 | Data Inputs |
| 18, 16, 14, 12 | 1Y1 to 1Y4 | Data Outputs |
| 19 | $\overline{2G}$ | Output Enable Input |
| 10 | GND | Ground (0V) |
| 20 | V_{CC} | Positive Supply Voltage |

TRUTH TABLE

| INPUTS | | OUTPUT |
|----------------|-------|--------|
| \overline{G} | A_n | Y_n |
| L | L | L |
| L | H | H |
| H | X | Z |

X : Don't Care

Z : High Impedance

ABSOLUTE MAXIMUM RATINGS

| Symbol | Parameter | Value | Unit |
|-----------------------|-------------------------------|------------------------|-------------|
| V_{CC} | Supply Voltage | -0.5 to +7 | V |
| V_I | DC Input Voltage | -0.5 to $V_{CC} + 0.5$ | V |
| V_O | DC Output Voltage | -0.5 to $V_{CC} + 0.5$ | V |
| I_{IK} | DC Input Diode Current | ± 20 | mA |
| I_{OK} | DC Output Diode Current | ± 20 | mA |
| I_O | DC Output Current | ± 50 | mA |
| I_{CC} or I_{GND} | DC V_{CC} or Ground Current | ± 400 | mA |
| T_{stg} | Storage Temperature | -65 to +150 | $^{\circ}C$ |
| T_L | Lead Temperature (10 sec) | 300 | $^{\circ}C$ |

Absolute Maximum Ratings are those values beyond which damage to the device may occur. Functional operation under these conditions is not implied.

RECOMMENDED OPERATING CONDITIONS

| Symbol | Parameter | Value | Unit |
|----------|--|---------------|-------------|
| V_{CC} | Supply Voltage | 4.5 to 5.5 | V |
| V_I | Input Voltage | 0 to V_{CC} | V |
| V_O | Output Voltage | 0 to V_{CC} | V |
| T_{op} | Operating Temperature | -55 to 125 | $^{\circ}C$ |
| dt/dv | Input Rise and Fall Time $V_{CC} = 4.5$ to $5.5V$ (note 1) | 8 | ns/V |

1) V_{IN} from 0.8V to 2.0V

DC SPECIFICATIONS

| Symbol | Parameter | Test Condition | | Value | | | | | | Unit | |
|------------------|---------------------------------------|------------------------|--|-----------------------|-------|-------|-------------|-------|--------------|------|------|
| | | V _{CC} (V) | | T _A = 25°C | | | -40 to 85°C | | -55 to 125°C | | |
| | | | | Min. | Typ. | Max. | Min. | Max. | Min. | | Max. |
| V _{IH} | High Level Input Voltage | 4.5 | V _O = 0.1 V or V _{CC} -0.1V | 2.0 | 1.5 | | 2.0 | | 2.0 | | V |
| | | 5.5 | | 2.0 | 1.5 | | 2.0 | | 2.0 | | |
| V _{IL} | Low Level Input Voltage | 4.5 | V _O = 0.1 V or V _{CC} -0.1V | | 1.5 | 0.8 | | 0.8 | | 0.8 | V |
| | | 5.5 | | | 1.5 | 0.8 | | 0.8 | | 0.8 | |
| V _{OH} | High Level Output Voltage | 4.5 | I _O =-50 μA | 4.4 | 4.49 | | 4.4 | | 4.4 | | V |
| | | 5.5 | I _O =-50 μA | 5.4 | 5.49 | | 5.4 | | 5.4 | | |
| | | 4.5 | I _O =-24 mA | 3.86 | | | 3.76 | | 3.7 | | V |
| | | 5.5 | I _O =-24 mA | 4.86 | | | 4.76 | | 4.7 | | |
| V _{OL} | Low Level Output Voltage | 4.5 | I _O =50 μA | | 0.001 | 0.1 | | 0.1 | | 0.1 | V |
| | | 5.5 | I _O =50 μA | | 0.001 | 0.1 | | 0.1 | | 0.1 | |
| | | 4.5 | I _O =24 mA | | | 0.36 | | 0.44 | | 0.5 | V |
| | | 5.5 | I _O =24 mA | | | 0.36 | | 0.44 | | 0.5 | |
| I _I | Input Leakage Current | 5.5 | V _I = V _{CC} or GND | | | ± 0.1 | | ± 1 | | ± 1 | μA |
| I _{OZ} | High Impedance Output Leakage Current | 5.5 | V _I = V _{IH} or V _{IL} V _O = V _{CC} or GND | | | ± 0.5 | | ± 2.5 | | ± 5 | μA |
| I _{CCT} | Max I _{CC} /Input | 5.5 | V _I = V _{CC} - 2.1V | | 0.6 | | | 1.5 | | 1.6 | mA |
| I _{CC} | Quiescent Supply Current | 5.5 | V _I = V _{CC} or GND | | | 4 | | 40 | | 80 | μA |
| I _{OLD} | Dynamic Output Current (note 1, 2) | 5.5 | V _{OLD} = 1.65 V max | | | | | 75 | | 50 | mA |
| I _{OHD} | | | V _{OHD} = 3.85 V min | | | | | -75 | | -50 | mA |

1) Maximum test duration 2ms, one output loaded at time

2) Incident wave switching is guaranteed on transmission lines with impedances as low as 50Ω

AC ELECTRICAL CHARACTERISTICS (C_L = 50 pF, R_L = 500 Ω, Input t_r = t_f = 3ns)

| Symbol | Parameter | Test Condition | | Value | | | | | | Unit | |
|-----------------------------------|------------------------|------------------------|--|-----------------------|------|------|-------------|------|--------------|------|------|
| | | V _{CC} (V) | | T _A = 25°C | | | -40 to 85°C | | -55 to 125°C | | |
| | | | | Min. | Typ. | Max. | Min. | Max. | Min. | | Max. |
| t _{PLH} t _{PHL} | Propagation Delay Time | 5.0(*) | | 1.5 | 4.6 | 9.0 | 1.5 | 10.0 | 1.5 | 11 | ns |
| t _{PZL} t _{PZH} | Output Enable Time | 5.0(*) | | 1.5 | 5.7 | 9.5 | 1.5 | 10.5 | 1.5 | 11 | ns |
| t _{PLZ} t _{PHZ} | Output Disable Time | 5.0(*) | | 1.5 | 6.4 | 10.0 | 1.5 | 11.0 | 1.5 | 11.5 | ns |

(*) Voltage range is 5.0V ± 0.5V

CAPACITIVE CHARACTERISTICS

| Symbol | Parameter | Test Condition | | Value | | | | | | Unit | |
|------------------|--|---------------------|-------------------------|-----------------------|------|------|-------------|------|--------------|------|------|
| | | V _{CC} (V) | | T _A = 25°C | | | -40 to 85°C | | -55 to 125°C | | |
| | | | | Min. | Typ. | Max. | Min. | Max. | Min. | | Max. |
| C _{IN} | Input Capacitance | 5.0 | | | 4 | | | | | | pF |
| C _{OUT} | Output Capacitance | 5.0 | | | 8 | | | | | | pF |
| C _{PD} | Power Dissipation Capacitance (note 1) | 5.0 | f _{IN} = 10MHz | | 24 | | | | | | pF |

1) C_{PD} is defined as the value of the IC's internal equivalent capacitance which is calculated from the operating current consumption without load. (Refer to Test Circuit). Average operating current can be obtained by the following equation. I_{CC(opr)} = C_{PD} × V_{CC} × f_{IN} + I_{CC/n} (per circuit)

TEST CIRCUIT

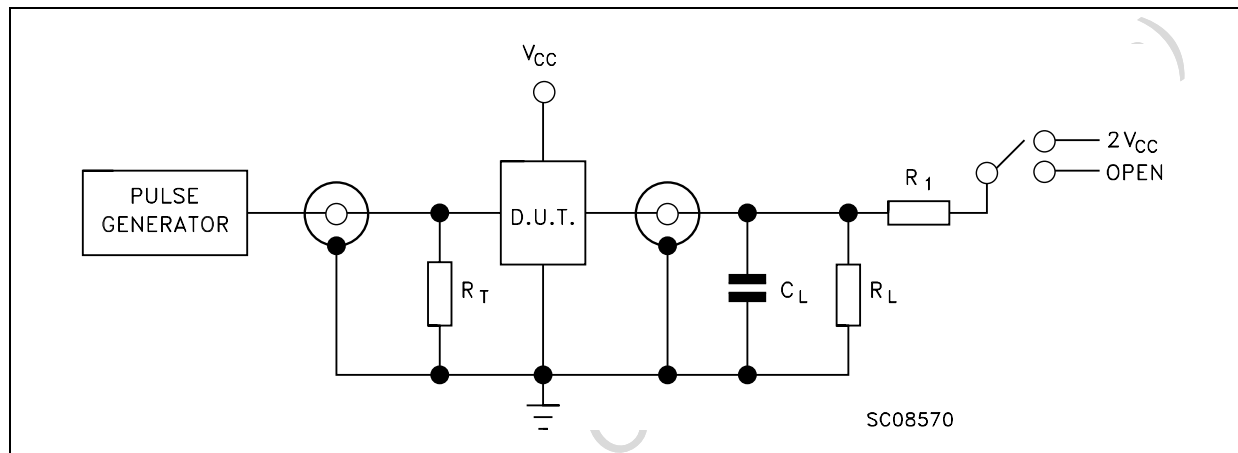

| TEST | SWITCH |
|-------------------------------------|------------------|
| t _{PLH} , t _{PHL} | Open |
| t _{PZL} , t _{PLZ} | 2V _{CC} |
| t _{PZH} , t _{PHZ} | Open |

C_L = 50pF or equivalent (includes jig and probe capacitance)
 R_L = R₁ = 500Ω or equivalent
 R_T = Z_{OUT} of pulse generator (typically 50Ω)

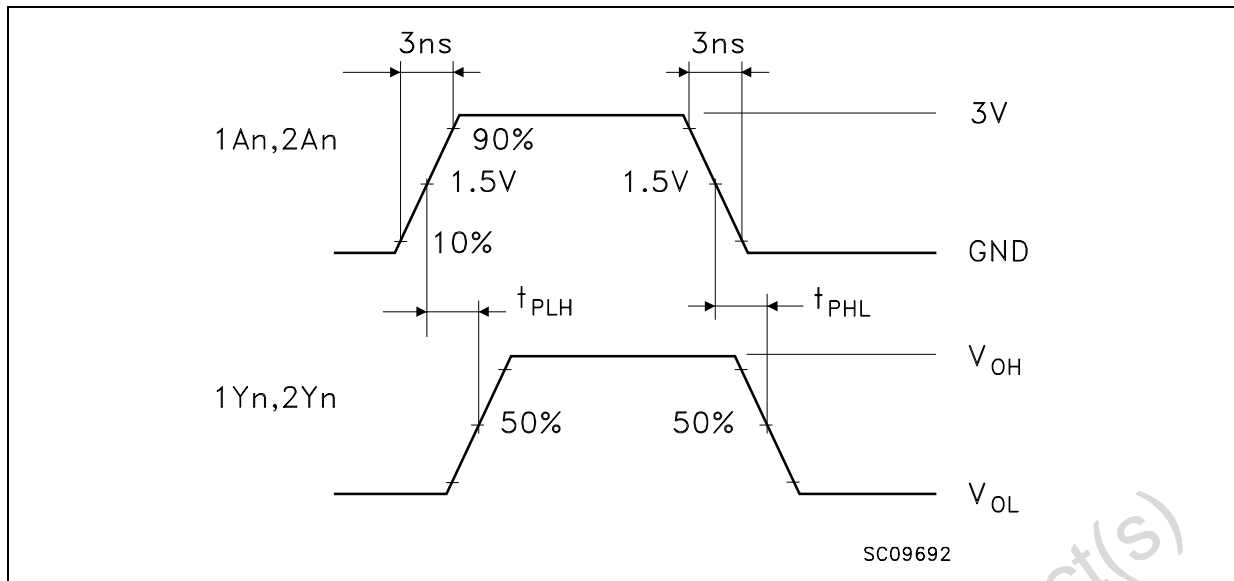
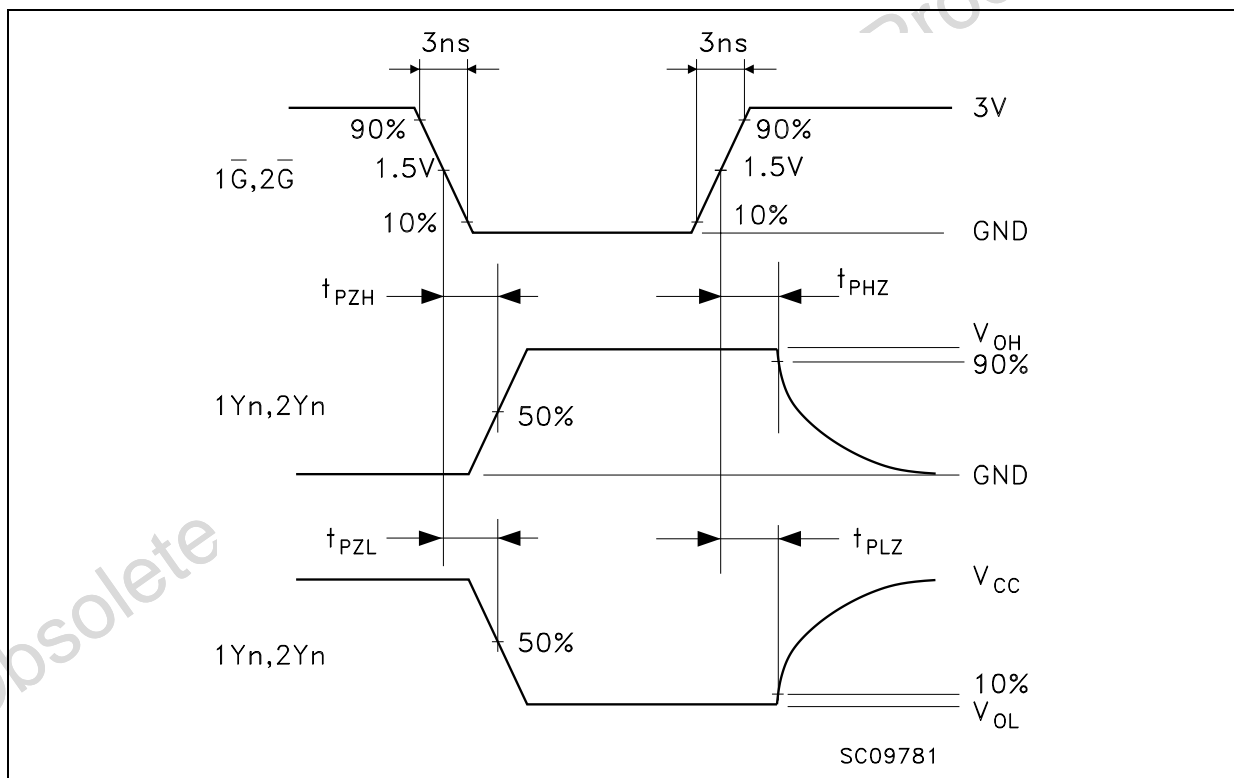
WAVEFORM 1: PROPAGATION DELAYS ($f=1\text{MHz}$; 50% duty cycle)**WAVEFORM 2: OUTPUT ENABLE AND DISABLE TIME** ($f=1\text{MHz}$; 50% duty cycle)

Plastic DIP-20 (0.25) MECHANICAL DATA

| DIM. | mm | | | inch | | |
|------|-------|-------|------|-------|-------|-------|
| | MIN. | TYP. | MAX. | MIN. | TYP. | MAX. |
| a1 | 0.254 | | | 0.010 | | |
| B | 1.39 | | 1.65 | 0.055 | | 0.065 |
| b | | 0.45 | | | 0.018 | |
| b1 | | 0.25 | | | 0.010 | |
| D | | | 25.4 | | | 1.000 |
| E | | 8.5 | | | 0.335 | |
| e | | 2.54 | | | 0.100 | |
| e3 | | 22.86 | | | 0.900 | |
| F | | | 7.1 | | | 0.280 |
| I | | | 3.93 | | | 0.155 |
| L | | 3.3 | | | 0.130 | |
| Z | | | 1.34 | | | 0.053 |

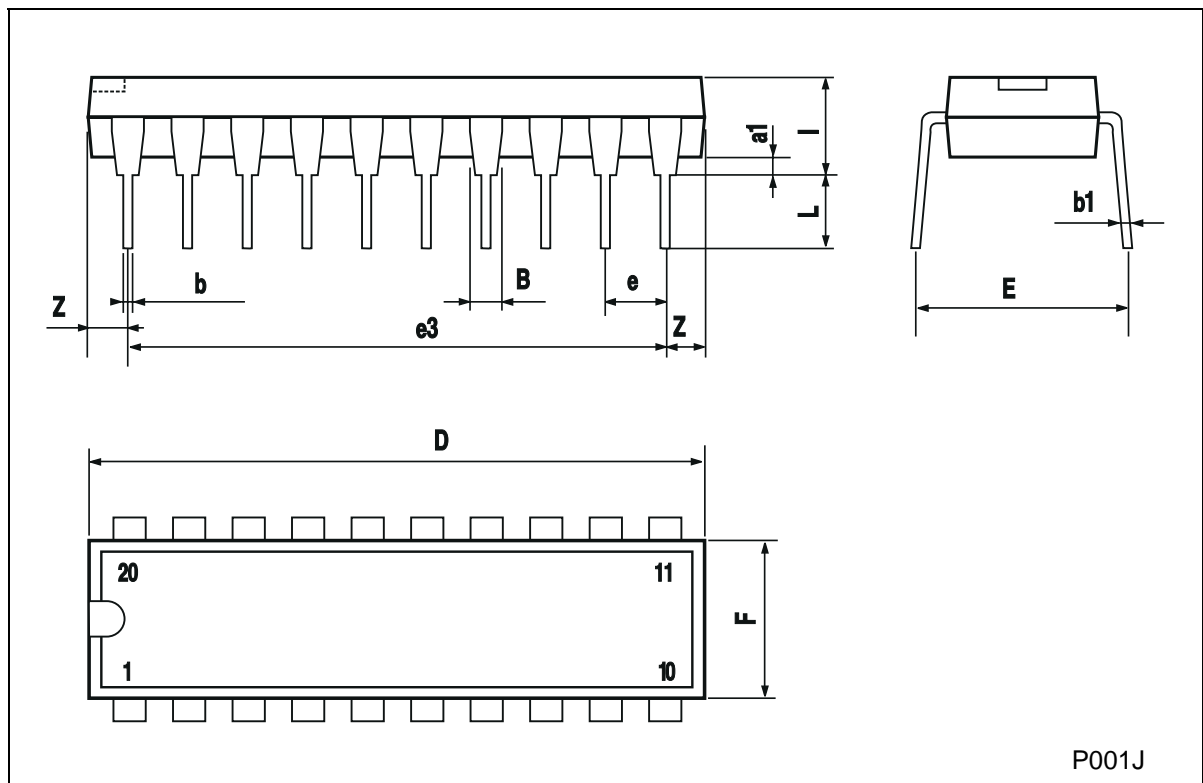

SO-20 MECHANICAL DATA

| DIM. | mm | | | inch | | |
|------|-----------|-------|-------|-------|-------|-------|
| | MIN. | TYP. | MAX. | MIN. | TYP. | MAX. |
| A | | | 2.65 | | | 0.104 |
| a1 | 0.10 | | 0.20 | 0.004 | | 0.007 |
| a2 | | | 2.45 | | | 0.096 |
| b | 0.35 | | 0.49 | 0.013 | | 0.019 |
| b1 | 0.23 | | 0.32 | 0.009 | | 0.012 |
| C | | 0.50 | | | 0.020 | |
| c1 | 45 (typ.) | | | | | |
| D | 12.60 | | 13.00 | 0.496 | | 0.512 |
| E | 10.00 | | 10.65 | 0.393 | | 0.419 |
| e | | 1.27 | | | 0.050 | |
| e3 | | 11.43 | | | 0.450 | |
| F | 7.40 | | 7.60 | 0.291 | | 0.299 |
| L | 0.50 | | 1.27 | 0.19 | | 0.050 |
| M | | | 0.75 | | | 0.029 |
| S | 8 (max.) | | | | | |

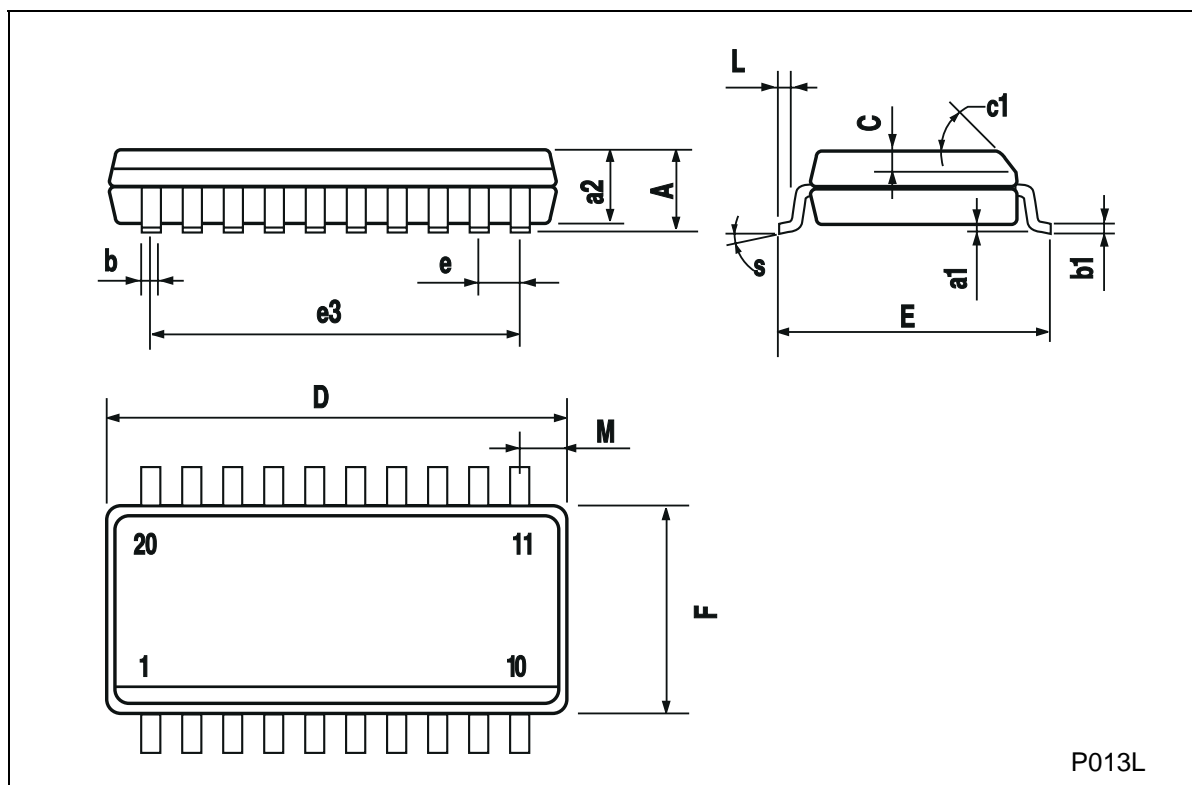

TSSOP20 MECHANICAL DATA

| DIM. | mm | | | inch | | |
|------|------|----------|------|--------|------------|--------|
| | MIN. | TYP. | MAX. | MIN. | TYP. | MAX. |
| A | | | 1.1 | | | 0.433 |
| A1 | 0.05 | 0.10 | 0.15 | 0.002 | 0.004 | 0.006 |
| A2 | 0.85 | 0.9 | 0.95 | 0.335 | 0.354 | 0.374 |
| b | 0.19 | | 0.30 | 0.0075 | | 0.0118 |
| c | 0.09 | | 0.2 | 0.0035 | | 0.0079 |
| D | 6.4 | 6.5 | 6.6 | 0.252 | 0.256 | 0.260 |
| E | 6.25 | 6.4 | 6.5 | 0.246 | 0.252 | 0.256 |
| E1 | 4.3 | 4.4 | 4.48 | 0.169 | 0.173 | 0.176 |
| e | | 0.65 BSC | | | 0.0256 BSC | |
| K | 0° | 4° | 8° | 0° | 4° | 8° |
| L | 0.50 | 0.60 | 0.70 | 0.020 | 0.024 | 0.028 |

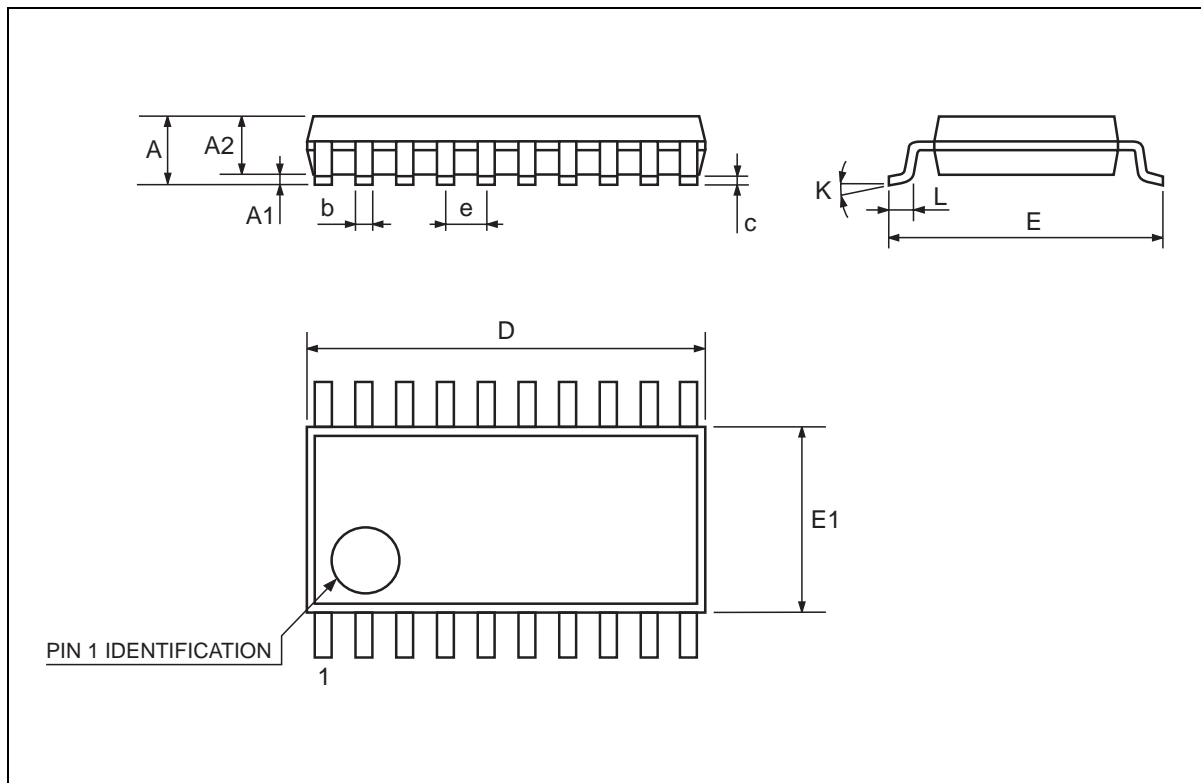

Obsolete Product(s) - Obsolete Product(s)

Information furnished is believed to be accurate and reliable. However, STMicroelectronics assumes no responsibility for the consequences of use of such information nor for any infringement of patents or other rights of third parties which may result from its use. No license is granted by implication or otherwise under any patent or patent rights of STMicroelectronics. Specifications mentioned in this publication are subject to change without notice. This publication supersedes and replaces all information previously supplied. STMicroelectronics products are not authorized for use as critical components in life support devices or systems without express written approval of STMicroelectronics.

© The ST logo is a registered trademark of STMicroelectronics

© 2001 STMicroelectronics - Printed in Italy - All Rights Reserved
STMicroelectronics GROUP OF COMPANIES

Australia - Brazil - China - Finland - France - Germany - Hong Kong - India - Italy - Japan - Malaysia - Malta - Morocco
Singapore - Spain - Sweden - Switzerland - United Kingdom

© <http://www.st.com>

