



Chipsmall Limited consists of a professional team with an average of over 10 year of expertise in the distribution of electronic components. Based in Hongkong, we have already established firm and mutual-benefit business relationships with customers from,Europe,America and south Asia,supplying obsolete and hard-to-find components to meet their specific needs.

With the principle of “Quality Parts,Customers Priority,Honest Operation,and Considerate Service”,our business mainly focus on the distribution of electronic components. Line cards we deal with include Microchip,ALPS,ROHM,Xilinx,Pulse,ON,Everlight and Freescale. Main products comprise IC,Modules,Potentiometer,IC Socket,Relay,Connector.Our parts cover such applications as commercial,industrial, and automotives areas.

We are looking forward to setting up business relationship with you and hope to provide you with the best service and solution. Let us make a better world for our industry!



Contact us

Tel: +86-755-8981 8866 Fax: +86-755-8427 6832

Email & Skype: info@chipsmall.com Web: www.chipsmall.com

Address: A1208, Overseas Decoration Building, #122 Zhenhua RD., Futian, Shenzhen, China



74ACT818 8-Bit Diagnostic Register

General Description

The ACT818 is a high-speed, general-purpose pipeline register with an on-board diagnostic register for performing serial diagnostics and/or writable control store loading.

The D-to-Y path provides an 8-bit parallel data path pipeline register for normal system operation. The diagnostic register can load parallel data to or from the pipeline register and can output data through the D input port (as in WCS loading).

The 8-bit diagnostic register has multiplexer inputs that select parallel inputs from the Y-port or adjacent bits in the diagnostic register to operate as a right-shift-only register. This register can then participate in a serial loop throughout the system where normal data, address, status and control registers are replaced with ACT818 diagnostic pipeline registers. The loop can be used to scan in a complete test routine starting point (Data, Address, etc.). Then after a specified number of machine cycles it scans out the results to be inspected for the expected results. WCS loading can be accomplished using the same technique. An instruction word can be serially shifted into the shadow register and written into the WCS RAM by enabling the D output.

Features

- On-line and off-line system diagnostics
- Swaps the contents of diagnostic register and output register
- Diagnostic register and diagnostic testing
- Cascadable for wide control words as used in microprogramming
- Edge-triggered D registers
- Outputs source/sink 24 mA
- ACT818 has TTL-compatible inputs
- ACT818 is functionally- and pin-compatible to AMD Am29818 and MMI 74S818

Applications

- Register for microprogram control store
- Status register
- Data register
- Instruction register
- Interrupt mask register
- Pipeline register
- General purpose register
- Parallel-serial/serial-parallel converter

Ordering Code:

Order Number	Order Package	Package Description
74ACT818SPC	N24C	24-Lead Plastic Dual-In-Line Package (PDIP), JEDEC MS-001, 0.300 Wide

Logic Symbol

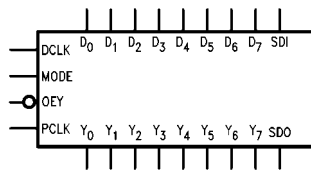

Connection Diagram

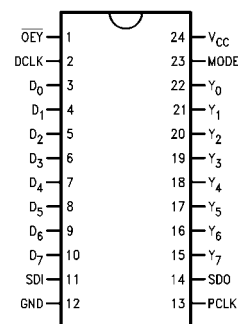

FACT™ is a trademark of Fairchild Semiconductor Corporation.

Pin Descriptions

Pin Names	Description
D ₀ -D ₇	Data Inputs
SDI	Serial Data Input
DCLK	Diagnostics Clock
MODE	Control Input
PCLK	Pipeline Register Clock

Functional Description

Data transfers into the diagnostic register occur on the LOW-to-HIGH transition of DCLK. Mode and SDI determine what data source will be loaded. The pipeline register is loaded on the LOW-to-HIGH transition of PCLK. Mode selects whether the data source is the data input or the diagnostic register output. Because of the independence of the clock inputs, data can be shifted in the diagnostic register via DCLK and loaded into the pipeline register from the data input via PCLK simultaneously, as long as no setup or hold times are violated. This simultaneous operation is legal.

Function Table

Inputs				Outputs			Operation
SDI	MODE	DCLK	PCLK	SDO	Diagnostic Reg.	Pipeline Reg.	
X	L	↗	X	S7	SI<SI - 1, SO<SD _I	NA	Serial Shift; D ₇ -D ₀ Disabled
X	L	X	↗	S7	NA	PI<DI	Normal Load Pipeline Register
L	H	↗	X	L	SI<Y _I	NA	Load Diagnostic Register from Y; DI Disabled
X	H	X	↗	SDI	NA	PI<SI	Load Pipeline Register from Diagnostic Register
H	H	↗	X	H	Hold	NA	Hold Diagnostic Register; DI Enabled

H = HIGH Voltage Level
 L = LOW Voltage Level
 X = Immaterial
 ↗ = LOW-to-HIGH Clock Transition

Diagnostic Register

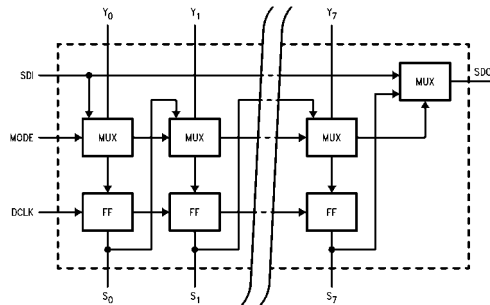

Block Diagram

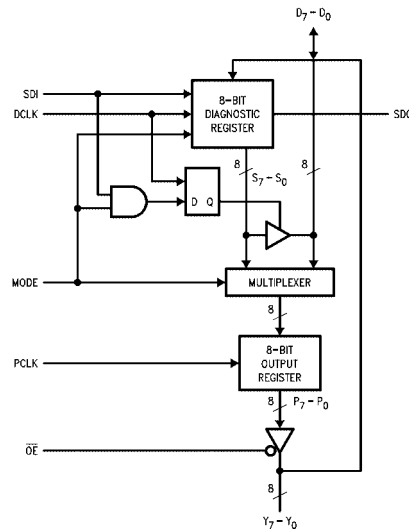

Absolute Maximum Ratings (Note 1)		Recommended Operating Conditions	
Supply Voltage (V_{CC})	-0.5V to +7.0V	Supply Voltage (V_{CC})	4.5V to 5.5V
DC Input Diode Current (I_{IK})		Input Voltage (V_I)	0V to V_{CC}
$V_I = -0.5V$	-20 mA	Output Voltage (V_O)	0V to V_{CC}
$V_I = V_{CC} + 0.5V$	+20 mA	Operating Temperature (T_A)	-40°C to +85°C
DC Input Voltage (V_I)	-0.5V to $V_{CC} + 0.5V$	Minimum Input Edge Rate ($\Delta V/\Delta t$)	125 mV/ns
DC Output Diode Current (I_{OK})		V_{IN} from 0.8V to 2.0V	
$V_O = -0.5V$	-20 mA	V_{CC} @ 4.5V, 5.5V	
$V_O = V_{CC} + 0.5V$	+20 mA		
DC Output Voltage (V_O)	-0.5V to $V_{CC} + 0.5V$		
DC Output Source			
or Sink Current (I_O)	± 50 mA		
DC V_{CC} or Ground Current			
per Output Pin (I_{CC} or I_{GND})	± 50 mA		
Storage Temperature (T_{STG})	-65°C to +150°C		
Junction Temperature (T_J)			
PDIP	140°C		

Note 1: Absolute maximum ratings are those values beyond which damage to the device may occur. The databook specifications should be met, without exception, to ensure that the system design is reliable over its power supply, temperature, and output/input loading variables. Fairchild does not recommend operation of FACT™ circuits outside databook specifications.

DC Electrical Characteristics

Symbol	Parameter	V_{CC} (V)	$T_A = +25^\circ\text{C}$		$T_A = -40^\circ\text{C to } +85^\circ\text{C}$		Units	Conditions
			Typ	Guaranteed Limits				
V_{IH}	Minimum HIGH Level Input Voltage	4.5	1.5	2.0	2.0	V	$V_{OUT} = 0.1V$ or $V_{CC} - 0.1V$	
		5.5	1.5	2.0	2.0			
V_{IL}	Maximum LOW Level Input Voltage	4.5	1.5	0.8	0.8	V	$V_{OUT} = 0.1V$ or $V_{CC} - 0.1V$	
		5.5	1.5	0.8	0.8			
I_{IN}	Maximum Input Leakage Current	5.5		± 0.1	± 1.0	μA	$V_{IN} = V_{CC}$	
I_{OZ}	Maximum 3-STATE Leakage Current	5.5		± 0.5	± 5.0	μA	$\overline{OE} = V_{IH}$ $V_{OUT} = 0V, V_{CC}$	
I_{CC}	Maximum Quiescent Supply Current	5.5		8.0	80.0	μA	$V_{IN} = V_{CC}$ or GND	
I_{CCT}	Maximum Additional I_{CC} /Input	5.5			1.5	mA	$V_{IN} = V_{CC} - 2.1V$ $V_{CC} = 5.5V$	
V_{OH}	Minimum HIGH Level Output Voltage, Y_0 - Y_7 Outputs	4.5		3.86	3.76	V	$V_{IN} = V_{IL}$ or V_{IH} $I_{OH} = -24$ mA	
		5.5		4.86	4.76	V	$I_{OH} = -24$ mA (Note 2)	
	Minimum HIGH Level Output Voltage, D_0 - D_7 , SDO Outputs	4.5		3.86	3.76	V	$I_{OH} = -8$ mA	
		5.5		4.86	4.76	V	$I_{OH} = -8$ mA	
V_{OL}	Maximum LOW Level Output Voltage, Y_0 - Y_7 Outputs	4.5		0.36	0.44	V	$V_{IN} = V_{IL}$ or V_{IH} $I_{OL} = 24$ mA	
		5.5		0.36	0.44	V	$I_{OL} = 24$ mA (Note 2)	
	Maximum LOW Level Output Voltage, D_0 - D_7 , SDO Outputs	4.5		0.36	0.44	V	$I_{OL} = 8$ mA	
		5.5		0.36	0.44	V	$I_{OL} = 8$ mA	
I_{OLD}	Minimum Dynamic Output Current Y_0 - Y_7 Outputs	5.5			75	mA	$V_{OLD} = 1.65V$ Max	
I_{OHD}	Minimum Dynamic Output Current Y_0 - Y_7 Outputs	5.5			-75	mA	$V_{OHD} = 3.85V$ Min	
I_{OLD}	Minimum Dynamic Output Current D_0 - D_7 , SDO Outputs (Note 3)	5.5			32	mA	$V_{OLD} = 1.65V$ Max	
I_{OHD}	Minimum Dynamic Output Current D_0 - D_7 , SDO Outputs (Note 3)	5.5			-32	mA	$V_{OHD} = 3.85V$ Min	

Note 2: All outputs loaded; thresholds on input associated with output under test.
Note 3: Test load 50 pF, 500 Ω to ground.

AC Electrical Characteristics								
Symbol	Parameter	V _{CC} (V) (Note 4)	T _A = +25°C C _L = 50 pF			T _A = -40°C to +85°C C _L = 50 pF		Units
			Min	Typ	Max	Min	Max	
t _{PHL}	Propagation Delay PCLK to Y	5.0	3.0	6.0	9.0	2.5	9.5	ns
t _{PLH}	Propagation Delay PCLK to Y	5.0	3.0	6.5	9.0	2.5	10.0	ns
t _{PHL}	Propagation Delay MODE to SDO	5.0	4.0	8.0	11.0	3.5	12.0	ns
t _{PLH}	Propagation Delay MODE to SDO	5.0	4.0	8.0	11.5	4.0	12.5	ns
t _{PHL}	Propagation Delay SDI to SDO	5.0	3.5	7.5	10.5	3.0	12.0	ns
t _{PLH}	Propagation Delay SDI to SDO	5.0	3.5	7.5	10.5	3.5	12.0	ns
t _{PHL}	Propagation Delay DCLK to SDO	5.0	4.5	9.0	12.5	4.0	14.0	ns
t _{PLH}	Propagation Delay DCLK to SDO	5.0	4.5	9.5	13.0	4.0	14.5	ns
t _{PZL}	Output Enable Time \overline{OEY} to Y _n	5.0	2.5	6.0	9.0	2.5	10.0	ns
t _{PLZ}	Output Disable Time \overline{OEY} to Y _n	5.0	1.5	5.5	8.0	1.0	9.0	ns
t _{PZL}	Output Enable Time DCLK to D _n	5.0	3.0	8.0	12.0	3.0	13.5	ns
t _{PLZ}	Output Disable Time DCLK to D _n	5.0	2.0	8.5	11.0	1.5	12.0	ns
t _{PZH}	Output Enable Time \overline{OEY} to Y _n	5.0	3.0	8.0	10.0	2.5	11.0	ns
t _{PHZ}	Output Disable Time \overline{OEY} to Y _n	5.0	2.5	9.0	11.0	2.0	11.5	ns
t _{PZH}	Output Enable Time DCLK to D _n	5.0	3.0	6.5	11.5	3.0	13.0	ns
t _{PHZ}	Output Disable Time DCLK to D _n	5.0	3.0	7.5	12.0	2.0	13.0	ns

Note 4: Voltage Range 5.0 is 5.0V ± 0.5V.

AC Operating Requirements						
Symbol	Parameter	V _{CC} (V) (Note 5)	T _A = +25°C C _L = 50 pF		T _A = -40°C to +85°C C _L = 50 pF	Units
			Typ	Guaranteed Minimum		
t _S	Setup Time D to PCLK	5.0	1.0	4.0	5.0	ns
t _H	Hold Time D to PCLK	5.0	0.0	1.0	1.0	ns
t _H	Setup Time MODE to PCLK	5.0	2.5	4.5	5.5	ns
t _H	Hold Time MODE to PCLK	5.0	-1.0	0.0	0.0	ns
t _S	Setup Time Y to DCLK	5.0	0.5	2.5	2.5	ns
t _S	Hold Time Y to DCLK	5.0	0	1.0	1.5	ns
t _S	Setup Time MODE to DCLK	5.0	2.0	4.0	4.0	ns
t _H	Hold Time MODE to DCLK	5.0	-0.5	1.0	1.0	ns
t _S	Setup Time SDI to DCLK	5.0	2.0	3.5	4.5	ns
t _H	Hold Time SDI to DCLK	5.0	-0.5	1.0	1.0	ns
t _S	Setup Time DCLK to PCLK	5.0	6.0	9.0	10.5	ns
t _S	Setup Time PCLK to DCLK	5.0	6.0	11.0	11.5	ns
t _W	Pulse Width PCLK HIGH or LOW	5.0	2.0	3.0	3.0	ns
t _W	Pulse Width DCLK HIGH or LOW	5.0	2.0	3.0	3.0	ns

Note 5: Voltage range 5.0 is 5.0V ± 0.5V.

Capacitance

Symbol	Parameter	Typ	Units	Conditions
C _{IN}	Input Capacitance	4.5	pF	V _{CC} = OPEN
C _{PD}	Power Dissipation Capacitance	20	pF	V _{CC} = 5.0V

Physical Dimensions inches (millimeters) unless otherwise noted

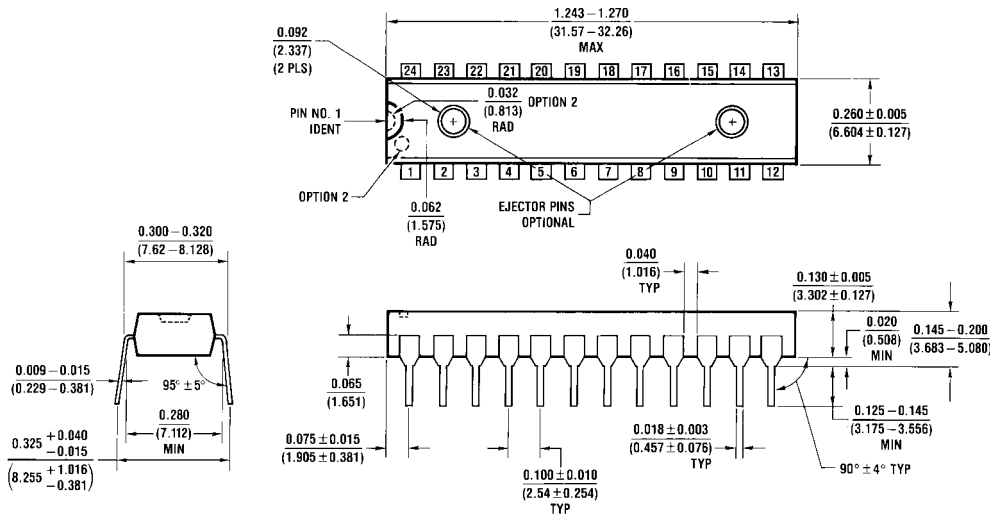

N24C (REV F)

24-Lead Plastic Dual-In-Line Package (PDIP), JEDEC MS-001, 0.300 Wide Package Number N24C

Fairchild does not assume any responsibility for use of any circuitry described, no circuit patent licenses are implied and Fairchild reserves the right at any time without notice to change said circuitry and specifications.

LIFE SUPPORT POLICY

FAIRCHILD'S PRODUCTS ARE NOT AUTHORIZED FOR USE AS CRITICAL COMPONENTS IN LIFE SUPPORT DEVICES OR SYSTEMS WITHOUT THE EXPRESS WRITTEN APPROVAL OF THE PRESIDENT OF FAIRCHILD SEMICONDUCTOR CORPORATION. As used herein:

1. Life support devices or systems are devices or systems which, (a) are intended for surgical implant into the body, or (b) support or sustain life, and (c) whose failure to perform when properly used in accordance with instructions for use provided in the labeling, can be reasonably expected to result in a significant injury to the user.
2. A critical component in any component of a life support device or system whose failure to perform can be reasonably expected to cause the failure of the life support device or system, or to affect its safety or effectiveness.

www.fairchildsemi.com