



Chipsmall Limited consists of a professional team with an average of over 10 year of expertise in the distribution of electronic components. Based in Hongkong, we have already established firm and mutual-benefit business relationships with customers from,Europe,America and south Asia,supplying obsolete and hard-to-find components to meet their specific needs.

With the principle of “Quality Parts,Customers Priority,Honest Operation,and Considerate Service”,our business mainly focus on the distribution of electronic components. Line cards we deal with include Microchip,ALPS,ROHM,Xilinx,Pulse,ON,Everlight and Freescale. Main products comprise IC,Modules,Potentiometer,IC Socket,Relay,Connector.Our parts cover such applications as commercial,industrial, and automotives areas.

We are looking forward to setting up business relationship with you and hope to provide you with the best service and solution. Let us make a better world for our industry!



## Contact us

Tel: +86-755-8981 8866 Fax: +86-755-8427 6832

Email & Skype: info@chipsmall.com Web: www.chipsmall.com

Address: A1208, Overseas Decoration Building, #122 Zhenhua RD., Futian, Shenzhen, China



# 74AHC1G66; 74AHCT1G66

Single-pole single-throw analog switch

Rev. 04 — 18 December 2008

Product data sheet

## 1. General description

74AHC1G66 and 74AHCT1G66 are high-speed Si-gate CMOS devices. They are single-pole single-throw analog switches. The switch has two input/output pins (Y and Z) and an active HIGH enable input pin (E). When pin E is LOW, the analog switch is turned off.

## 2. Features

- Very low ON resistance:
  - ◆ 26  $\Omega$  (typ.) at  $V_{CC} = 3.0\text{ V}$
  - ◆ 16  $\Omega$  (typ.) at  $V_{CC} = 4.5\text{ V}$
  - ◆ 14  $\Omega$  (typ.) at  $V_{CC} = 5.5\text{ V}$
- High noise immunity
- Low power dissipation
- Balanced propagation delays
- Multiple package options
- ESD protection:
  - ◆ HMB JESD22-A114E exceeds 2000 V
  - ◆ MM JESD22-A115-A exceeds 200 V
  - ◆ CDM JESD22-C101C exceeds 1000 V
- Specified from  $-40\text{ }^{\circ}\text{C}$  to  $+85\text{ }^{\circ}\text{C}$  and  $-40\text{ }^{\circ}\text{C}$  to  $+125\text{ }^{\circ}\text{C}$

## 3. Ordering information

Table 1. Ordering information

| Type number                 | Package   |        |   |          |
|-----------------------------|---|--------|---|----------|
|                             | Temperature range   | Name   | Description   | Version  |
| 74AHC1G66GW<br>74AHCT1G66GW | $-40\text{ }^{\circ}\text{C}$ to $+125\text{ }^{\circ}\text{C}$ | TSSOP5 | plastic thin shrink small outline package;<br>5 leads; body width 1.25 mm | SOT353-1 |
| 74AHC1G66GV<br>74AHCT1G66GV | $-40\text{ }^{\circ}\text{C}$ to $+125\text{ }^{\circ}\text{C}$ | SC-74A | plastic surface-mounted package; 5 leads                                  | SOT753   |

## 4. Marking

Table 2. Marking codes

| Type number  | Marking |
|--------------|---------|
| 74AHC1G66GW  | AL      |
| 74AHCT1G66GW | CL      |
| 74AHC1G66GV  | A66     |
| 74AHCT1G66GV | C66     |

## 5. Functional diagram

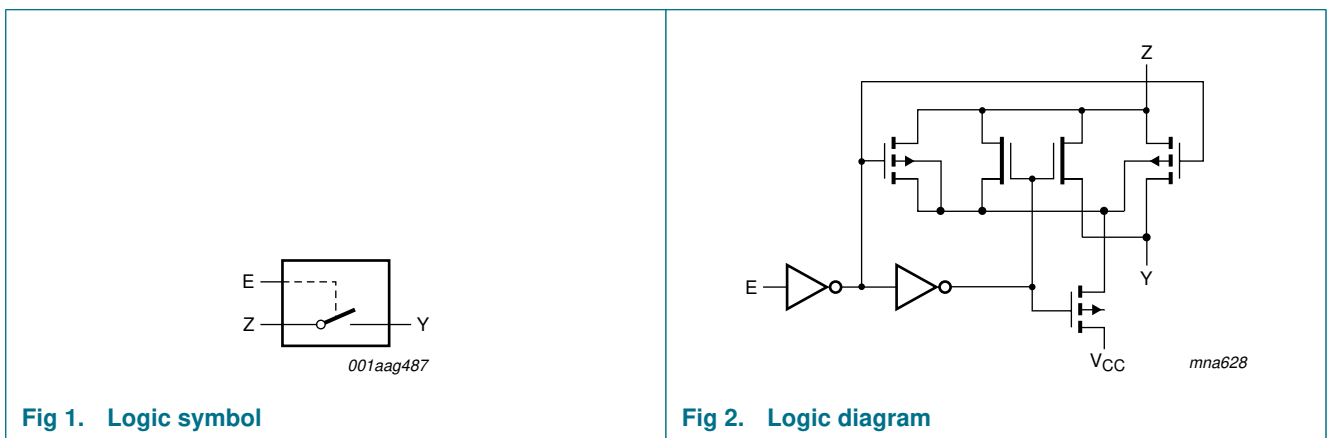

Fig 1. Logic symbol

Fig 2. Logic diagram

## 6. Pinning information

### 6.1 Pinning

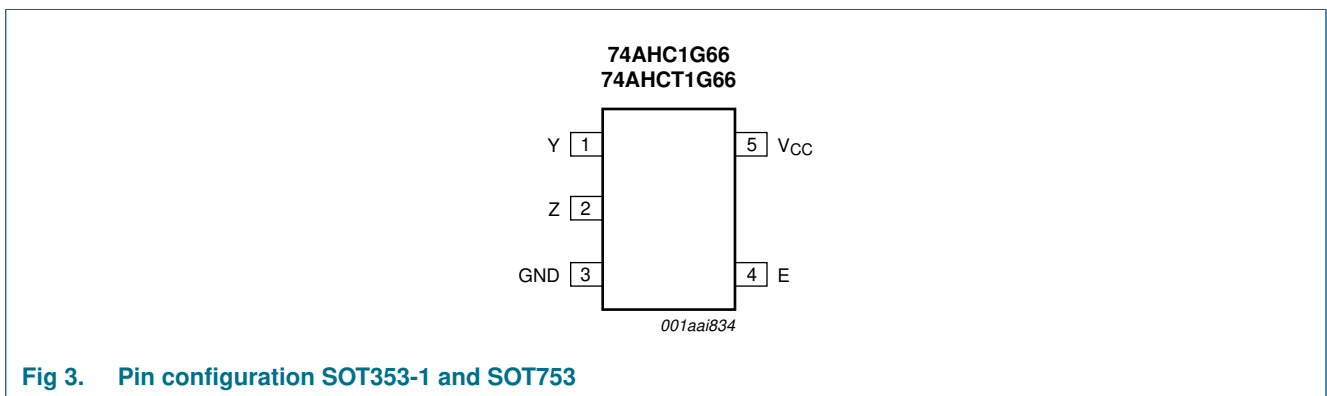

Fig 3. Pin configuration SOT353-1 and SOT753

## 6.2 Pin description

**Table 3. Pin description**

| Symbol          | Pin | Description                 |
|-----------------|-----|-----------------------------|
| Y               | 1   | independent input or output |
| Z               | 2   | independent input or output |
| GND             | 3   | ground (0 V)                |
| E               | 4   | enable input (active HIGH)  |
| V <sub>CC</sub> | 5   | supply voltage              |

## 7. Functional description

**Table 4. Function table<sup>[1]</sup>**

| Input E | Switch |
|---------|--------|
| L       | OFF    |
| H       | ON     |

[1] H = HIGH voltage level; L = LOW voltage level.

## 8. Limiting values

**Table 5. Limiting values**

In accordance with the Absolute Maximum Rating System (IEC 60134). Voltages are referenced to GND (ground = 0 V).

| Symbol           | Parameter               | Conditions  | Min                | Max  | Unit |
|------------------|-------------------------|---|--------------------|------|------|
| V <sub>CC</sub>  | supply voltage          |   | -0.5               | +7.0 | V    |
| I <sub>IK</sub>  | input clamping current  | V <sub>I</sub> < -0.5 V   | <sup>[1]</sup> -20 | -    | mA   |
| I <sub>SK</sub>  | switch clamping current | V <sub>I</sub> < -0.5 V or V <sub>I</sub> > V <sub>CC</sub> + 0.5 V | <sup>[1]</sup> -   | ±20  | mA   |
| I <sub>SW</sub>  | switch current          | -0.5 V < V <sub>O</sub> < V <sub>CC</sub> + 0.5 V                   | -                  | ±25  | mA   |
| I <sub>CC</sub>  | supply current          |   | -                  | 75   | mA   |
| I <sub>GND</sub> | ground current          |   | -75                | -    | mA   |
| T <sub>stg</sub> | storage temperature     |   | -65                | +150 | °C   |
| P <sub>tot</sub> | total power dissipation | T <sub>amb</sub> = -40 °C to +125 °C                                | <sup>[2]</sup> -   | 250  | mW   |

[1] The input and output voltage ratings may be exceeded if the input and output voltage ratings are observed.

[2] For TSSOP5 and SC-74A packages: above 87.5 °C the value of P<sub>tot</sub> derates linearly with 4.0 mW/K.

## 9. Recommended operating conditions

**Table 6. Recommended operating conditions**

Voltages are referenced to GND (ground = 0 V).<sup>[1]</sup>

| Symbol          | Parameter      | Conditions | 74AHC1G66 |     |                 | 74AHCT1G66 |     |                 | Unit |
|-----------------|----------------|------------|-----------|-----|-----------------|------------|-----|-----------------|------|
|                 |                |            | Min       | Typ | Max             | Min        | Typ | Max             |      |
| V <sub>CC</sub> | supply voltage |            | 2.0       | 5.0 | 5.5             | 4.5        | 5.0 | 5.5             | V    |
| V <sub>I</sub>  | input voltage  |            | 0         | -   | 5.5             | 0          | -   | 5.5             | V    |
| V <sub>SW</sub> | switch voltage |            | 0         | -   | V <sub>CC</sub> | 0          | -   | V <sub>CC</sub> | V    |

**Table 6. Recommended operating conditions ...continued**

*Voltages are referenced to GND (ground = 0 V).*<sup>[1]</sup>

| Symbol           | Parameter                           | Conditions                                   | 74AHC1G66 |     |      | 74AHCT1G66 |     |      | Unit |
|------------------|-------------------------------------|--|-----------|-----|------|------------|-----|------|------|
|                  |                                     |  | Min       | Typ | Max  | Min        | Typ | Max  |      |
| T <sub>amb</sub> | ambient temperature                 |  | -40       | +25 | +125 | -40        | +25 | +125 | °C   |
| Δt/ΔV            | input transition rise and fall rate | V <sub>CC</sub> = 3.3 ± 0.3 V <sup>[2]</sup> | -         | -   | 100  | -          | -   | -    | ns/V |
|                  |                                     | V <sub>CC</sub> = 5.0 ± 0.5 V <sup>[2]</sup> | -         | -   | 20   | -          | -   | 20   | ns/V |

[1] To avoid drawing V<sub>CC</sub> current out of pin Z, when switch current flows in pin Y, the voltage drop across the bidirectional switch must not exceed 0.4 V. If the switch current flows into pin Z, no V<sub>CC</sub> current will flow out of terminal Y. In this case there is no limit for the voltage drop across the switch, but the voltage at pins Y and Z may not exceed V<sub>CC</sub> or GND.

[2] Applies to control signal levels.

## 10. Static characteristics

**Table 7. Static characteristics**

*Voltages are referenced to GND (ground = 0 V).*

| Symbol              | Parameter                 | Conditions  | 25 °C |     |      | -40 °C to +85 °C |      | -40 °C to +125 °C |      | Unit |
|---------------------|---------------------------|---|-------|-----|------|------------------|------|-------------------|------|------|
|                     |                           |   | Min   | Typ | Max  | Min              | Max  | Min               | Max  |      |
| <b>74AHC1G66</b>    |                           |   |       |     |      |                  |      |                   |      |      |
| V <sub>IH</sub>     | HIGH-level input voltage  | V <sub>CC</sub> = 2.0 V                                       | 1.5   | -   | -    | 1.5              | -    | 1.5               | -    | V    |
|                     |                           | V <sub>CC</sub> = 3.0 V                                       | 2.1   | -   | -    | 2.1              | -    | 2.1               | -    | V    |
|                     |                           | V <sub>CC</sub> = 5.5 V                                       | 3.85  | -   | -    | 3.85             | -    | 3.85              | -    | V    |
| V <sub>IL</sub>     | LOW-level input voltage   | V <sub>CC</sub> = 2.0 V                                       | -     | -   | 0.5  | -                | 0.5  | -                 | 0.5  | V    |
|                     |                           | V <sub>CC</sub> = 3.0 V                                       | -     | -   | 0.9  | -                | 0.9  | -                 | 0.9  | V    |
|                     |                           | V <sub>CC</sub> = 5.5 V                                       | -     | -   | 1.65 | -                | 1.65 | -                 | 1.65 | V    |
| I <sub>I</sub>      | input leakage current     | V <sub>I</sub> = 5.5 V or GND; V <sub>CC</sub> = 5.5 V        | -     | -   | 0.1  | -                | 1.0  | -                 | 2.0  | μA   |
| I <sub>S(OFF)</sub> | OFF-state leakage current | Y or Z; V <sub>CC</sub> = 5.5 V; see <a href="#">Figure 4</a> | -     | -   | 0.1  | -                | 1.0  | -                 | 4.0  | μA   |
| I <sub>S(ON)</sub>  | ON-state leakage current  | Y or Z; V <sub>CC</sub> = 5.5 V; see <a href="#">Figure 5</a> | -     | -   | 0.1  | -                | 1.0  | -                 | 4.0  | μA   |
| I <sub>CC</sub>     | supply current            | E, Y or Z = V <sub>CC</sub> or GND; V <sub>CC</sub> = 5.5 V   | -     | -   | 1.0  | -                | 10   | -                 | 40   | μA   |
| C <sub>I</sub>      | input capacitance         | E input   | -     | 2.0 | 10   | -                | 10   | -                 | 10   | pF   |
| C <sub>S(ON)</sub>  | ON-state capacitance      | Y or Z input or output  | -     | 4.0 | 10   | -                | 10   | -                 | 10   | pF   |
| <b>74AHCT1G66</b>   |                           |   |       |     |      |                  |      |                   |      |      |
| V <sub>IH</sub>     | HIGH-level input voltage  | V <sub>CC</sub> = 4.5 V to 5.5 V                              | 2.0   | -   | -    | 2.0              | -    | 2.0               | -    | V    |
| V <sub>IL</sub>     | LOW-level input voltage   | V <sub>CC</sub> = 4.5 V to 5.5 V                              | -     | -   | 0.8  | -                | 0.8  | -                 | 0.8  | V    |
| I <sub>I</sub>      | input leakage current     | V <sub>I</sub> = 5.5 V or GND; V <sub>CC</sub> = 5.5 V        | -     | -   | 0.1  | -                | 1.0  | -                 | 2.0  | μA   |

**Table 7. Static characteristics ...continued**  
 Voltages are referenced to GND (ground = 0 V).

| Symbol          | Parameter                 | Conditions  | 25 °C |     |      | -40 °C to +85 °C |     | -40 °C to +125 °C |     | Unit          |
|-----------------|---------------------------|---|-------|-----|------|------------------|-----|-------------------|-----|---------------|
|                 |                           |   | Min   | Typ | Max  | Min              | Max | Min               | Max |               |
| $I_{S(OFF)}$    | OFF-state leakage current | Y or Z; $V_{CC} = 5.5\text{ V}$ ; see <a href="#">Figure 4</a>  | -     | -   | 0.1  | -                | 1.0 | -                 | 4.0 | $\mu\text{A}$ |
| $I_{S(ON)}$     | ON-state leakage current  | Y or Z; $V_{CC} = 5.5\text{ V}$ ; see <a href="#">Figure 5</a>  | -     | -   | 0.1  | -                | 1.0 | -                 | 4.0 | $\mu\text{A}$ |
| $I_{CC}$        | supply current            | E, Y or Z = $V_{CC}$ or GND; $V_{CC} = 5.5\text{ V}$  | -     | -   | 1.0  | -                | 10  | -                 | 40  | $\mu\text{A}$ |
| $\Delta I_{CC}$ | additional supply current | per input pin; $V_I = 3.4\text{ V}$ ; other inputs at $V_{CC}$ or GND; $I_O = 0\text{ A}$ ; $V_{CC} = 5.5\text{ V}$ | -     | -   | 1.35 | -                | 1.5 | -                 | 1.5 | $\text{mA}$   |
| $C_I$           | input capacitance         | E input   | -     | 2.0 | 10   | -                | 10  | -                 | 10  | $\text{pF}$   |
| $C_{S(ON)}$     | ON-state capacitance      | Y or Z input or output  | -     | 4.0 | 10   | -                | 10  | -                 | 10  | $\text{pF}$   |

## 10.1 Test circuits

$V_I = V_{CC}$  or GND and  $V_O = \text{GND}$  or  $V_{CC}$ .

**Fig 4. Test circuit for measuring OFF-state leakage current**

$V_I = V_{CC}$  or GND and  $V_O = \text{open circuit}$ .

**Fig 5. Test circuit for measuring ON-state leakage current**

## 10.2 ON resistance

**Table 8. ON resistance**

At recommended operating conditions; voltages are referenced to GND (ground 0 V); for graph see [Figure 7 \[1\]](#).

| Symbol                          | Parameter            | Conditions  | 25 °C              |     | -40 °C to +85 °C | -40 °C to +125 °C | Unit |
|---------------------------------|----------------------|---|--------------------|-----|------------------|-------------------|------|
|                                 |                      |   | Typ                | max | Max              | Max               |      |
| <b>74AHC1G66 and 74AHCT1G66</b> |                      |   |                    |     |                  |                   |      |
| R <sub>ON(peak)</sub>           | ON resistance (peak) | V <sub>I</sub> = V <sub>CC</sub> to GND; see <a href="#">Figure 6</a> |                    |     |                  |                   |      |
|                                 |                      | I <sub>SW</sub> = 1.0 mA; V <sub>CC</sub> = 2.0 V                     | 148 <sup>[1]</sup> | -   | -                | -                 | Ω    |
|                                 |                      | I <sub>SW</sub> = 10 mA; V <sub>CC</sub> = 3.0 V to 3.6 V             | 28                 | 50  | 70               | 110               | Ω    |
|                                 |                      | I <sub>SW</sub> = 10 mA; V <sub>CC</sub> = 4.5 V to 5.5 V             | 15                 | 30  | 40               | 60                | Ω    |
| R <sub>ON(rail)</sub>           | ON resistance (rail) | V <sub>I</sub> = GND; see <a href="#">Figure 6</a>                    |                    |     |                  |                   |      |
|                                 |                      | I <sub>SW</sub> = 1.0 mA; V <sub>CC</sub> = 2.0 V                     | 30                 | -   | -                | -                 | Ω    |
|                                 |                      | I <sub>SW</sub> = 10 mA; V <sub>CC</sub> = 3.0 V to 3.6 V             | 20                 | 50  | 65               | 90                | Ω    |
|                                 |                      | I <sub>SW</sub> = 10 mA; V <sub>CC</sub> = 4.5 V to 5.5 V             | 15                 | 22  | 26               | 40                | Ω    |
|                                 |                      | V <sub>I</sub> = V <sub>CC</sub> ; see <a href="#">Figure 6</a>       |                    |     |                  |                   |      |
|                                 |                      | I <sub>SW</sub> = 1.0 mA; V <sub>CC</sub> = 2.0 V                     | 28                 | -   | -                | -                 | Ω    |
|                                 |                      | I <sub>SW</sub> = 10 mA; V <sub>CC</sub> = 3.0 V to 3.6 V             | 18                 | 50  | 65               | 90                | Ω    |
|                                 |                      | I <sub>SW</sub> = 10 mA; V <sub>CC</sub> = 4.5 V to 5.5 V             | 13                 | 22  | 26               | 40                | Ω    |

[1] At supply voltages approaching 2 V, the analog switch ON resistance becomes extremely non-linear. Therefore it is recommended that these devices be used to transmit digital signals only, when using this supply voltage.

## 10.3 ON resistance test circuit and graphs

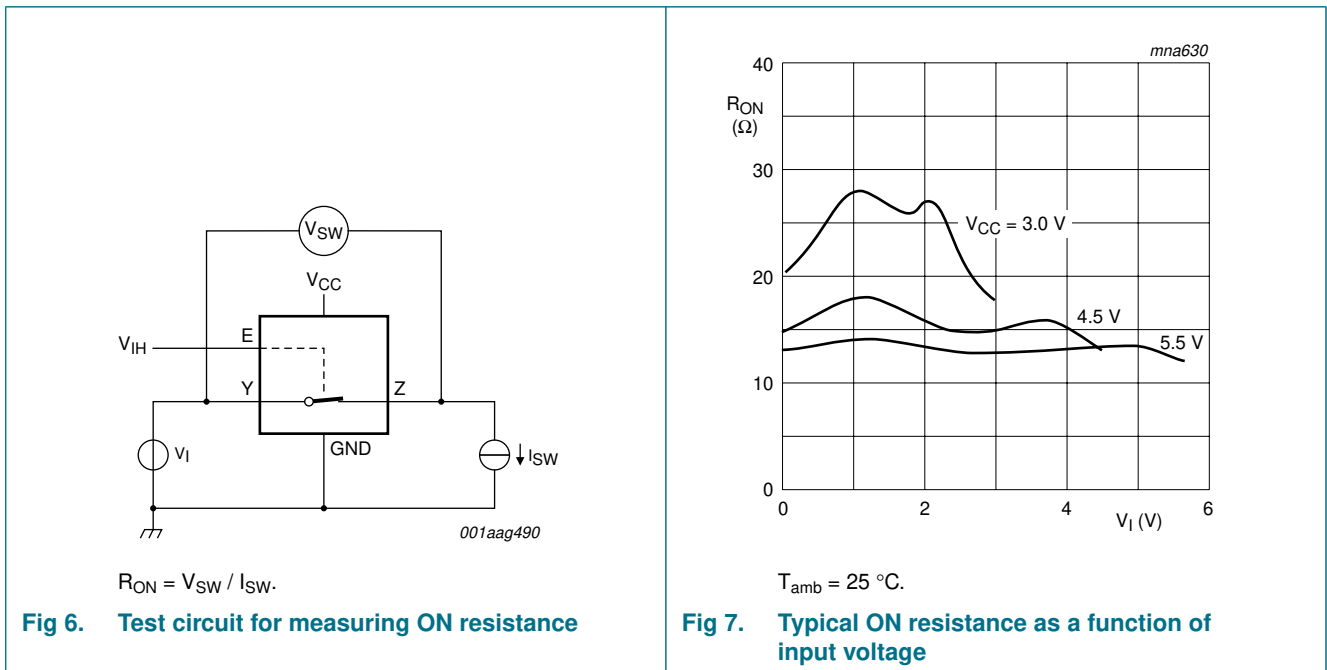

## 11. Dynamic characteristics

**Table 9. Dynamic characteristics**

Voltages are referenced to GND (ground = 0 V);  $C_L = 50$  pF; unless otherwise specified; For test circuit see [Figure 10](#).

| Symbol            | Parameter                     | Conditions  | 25 °C              |      | -40 °C to +85 °C | -40 °C to +125 °C | Unit |
|-------------------|-------------------------------|---|--------------------|------|------------------|-------------------|------|
|                   |                               |   | Typ <sup>[1]</sup> | max  | Max              | Max               |      |
| <b>74AHC1G66</b>  |                               |   |                    |      |                  |                   |      |
| $t_{pd}$          | propagation delay             | Y to Z or Z to Y; see <a href="#">Figure 8</a> <sup>[2]</sup> |                    |      |                  |                   |      |
|                   |                               | $V_{CC} = 2.0$ V  | 2.2                | 5.0  | 6.0              | 7.0               | ns   |
|                   |                               | $V_{CC} = 3.0$ V to 3.6 V                                     | 1.0                | 2.0  | 3.0              | 4.0               | ns   |
|                   |                               | $V_{CC} = 4.5$ V to 5.5 V                                     | 0.6                | 1.0  | 2.0              | 3.0               | ns   |
| $t_{en}$          | enable time                   | E to Y or Z; see <a href="#">Figure 9</a> <sup>[2]</sup>      |                    |      |                  |                   |      |
|                   |                               | $V_{CC} = 2.0$ V; $C_L = 15$ pF                               | 7.0                | 25.0 | 33.0             | 40.0              | ns   |
|                   |                               | $V_{CC} = 2.0$ V  | 11.0               | 35.0 | 46.0             | 57.0              | ns   |
|                   |                               | $V_{CC} = 3.0$ V to 3.6 V;<br>$C_L = 15$ pF                   | 4.0                | 11.0 | 14.0             | 18.0              | ns   |
|                   |                               | $V_{CC} = 3.0$ V to 3.6 V                                     | 5.8                | 15.0 | 20.0             | 25.0              | ns   |
|                   |                               | $V_{CC} = 4.5$ V to 5.5 V;<br>$C_L = 15$ pF                   | 3.0                | 8.0  | 10.0             | 13.0              | ns   |
|                   |                               | $V_{CC} = 4.5$ V to 5.5 V                                     | 4.0                | 11.0 | 13.0             | 17.0              | ns   |
| $t_{dis}$         | disable time                  | E to Y or Z; see <a href="#">Figure 9</a> <sup>[2]</sup>      |                    |      |                  |                   |      |
|                   |                               | $V_{CC} = 2.0$ V; $C_L = 15$ pF                               | 9.0                | 25.0 | 33.0             | 40.0              | ns   |
|                   |                               | $V_{CC} = 2.0$ V  | 13.0               | 35.0 | 46.0             | 57.0              | ns   |
|                   |                               | $V_{CC} = 3.0$ V to 3.6 V;<br>$C_L = 15$ pF                   | 6.0                | 11.0 | 14.0             | 18.0              | ns   |
|                   |                               | $V_{CC} = 3.0$ V to 3.6 V                                     | 8.4                | 15.0 | 20.0             | 25.0              | ns   |
|                   |                               | $V_{CC} = 4.5$ V to 5.5 V;<br>$C_L = 15$ pF                   | 5.0                | 8.0  | 10.0             | 13.0              | ns   |
|                   |                               | $V_{CC} = 4.5$ V to 5.5 V                                     | 6.1                | 11.0 | 13.0             | 17.0              | ns   |
| $C_{PD}$          | power dissipation capacitance | $V_I = \text{GND to } V_{CC}$ <sup>[3]</sup>                  | 13                 | -    | -                | -                 | pF   |
| <b>74AHCT1G66</b> |                               |   |                    |      |                  |                   |      |
| $t_{pd}$          | propagation delay             | Y to Z or Z to Y; see <a href="#">Figure 8</a> <sup>[2]</sup> |                    |      |                  |                   |      |
|                   |                               | $V_{CC} = 4.5$ V to 5.5 V                                     | 0.7                | 1.0  | 2.0              | 3.0               | ns   |
| $t_{en}$          | enable time                   | E to Y or Z; see <a href="#">Figure 9</a> <sup>[2]</sup>      |                    |      |                  |                   |      |
|                   |                               | $V_{CC} = 4.5$ V to 5.5 V;<br>$C_L = 15$ pF                   | 3.0                | 7.0  | 10.0             | 13.0              | ns   |
|                   |                               | $V_{CC} = 4.5$ V to 5.5 V                                     | 4.7                | 10.0 | 13.0             | 17.0              | ns   |
| $t_{dis}$         | disable time                  | E to Y or Z; see <a href="#">Figure 9</a> <sup>[2]</sup>      |                    |      |                  |                   |      |
|                   |                               | $V_{CC} = 4.5$ V to 5.5 V;<br>$C_L = 15$ pF                   | 5.0                | 8.0  | 10.0             | 13.0              | ns   |
|                   |                               | $V_{CC} = 4.5$ V to 5.5 V                                     | 6.5                | 11.0 | 13.0             | 17.0              | ns   |



**Table 9. Dynamic characteristics ...continued**

Voltages are referenced to GND (ground = 0 V);  $C_L = 50$  pF; unless otherwise specified; For test circuit see [Figure 10](#).

| Symbol   | Parameter                     | Conditions                    | 25 °C              |     | -40 °C to +85 °C | -40 °C to +125 °C | Unit |
|----------|-------------------------------|-------------------------------|--------------------|-----|------------------|-------------------|------|
|          |                               |                               | Typ <sup>[1]</sup> | max | Max              | Max               |      |
| $C_{PD}$ | power dissipation capacitance | $V_I = \text{GND to } V_{CC}$ | <sup>[3]</sup> 15  | -   | -                | -                 | pF   |

[1] All typical values are measured at  $V_{CC} = 2.0$  V,  $V_{CC} = 3.3$  V,  $V_{CC} = 5.0$  V and  $T_{amb} = 25$  °C.

[2]  $t_{pd}$  is the same as  $t_{PLH}$  and  $t_{PHL}$ .

$t_{en}$  is the same as  $t_{PZL}$  and  $t_{PZH}$ .

$t_{dis}$  is the same as  $t_{PLZ}$  and  $t_{PHZ}$ .

[3]  $C_{PD}$  is used to determine the dynamic power dissipation  $P_D$  ( $\mu$ W).

$P_D = C_{PD} \times V_{CC}^2 \times f_i + \Sigma ((C_L \times C_{SW}) \times V_{CC}^2 \times f_o)$  where:

$f_i$  = input frequency in MHz;

$f_o$  = output frequency in MHz;

$C_L$  = output load capacitance in pF;

$C_{SW}$  = maximum switch capacitance in pF (see [Table 7](#));

$V_{CC}$  = supply voltage in Volt;

$\Sigma ((C_L \times C_{SW}) \times V_{CC}^2 \times f_o)$  = sum of outputs.

### 11.1 Waveforms and test circuit

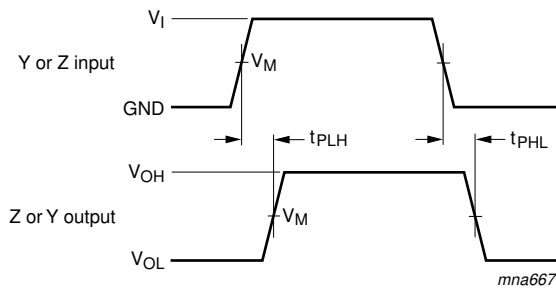

Measurement points are given in [Table 10](#).

Logic levels:  $V_{OL}$  and  $V_{OH}$  are typical output voltage levels that occur with the output load.

**Fig 8. Input (Y or Z) to output (Z or Y) propagation delays**

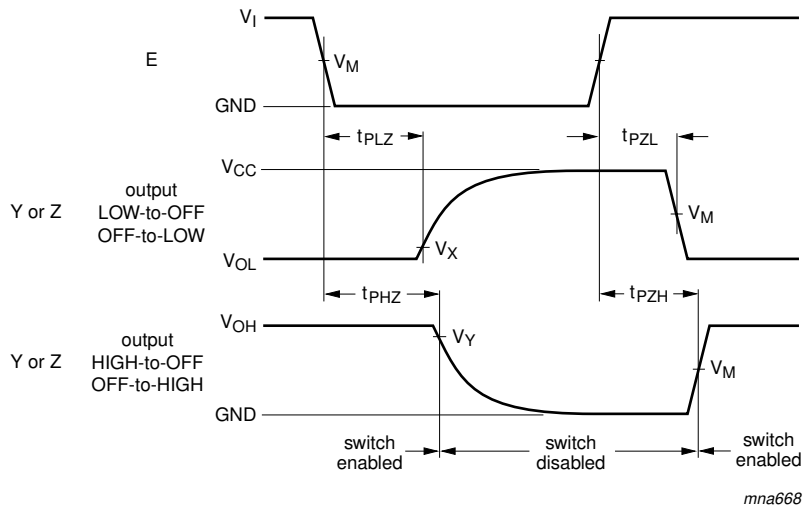

Measurement points are given in [Table 10](#).

Logic levels:  $V_{OL}$  and  $V_{OH}$  are typical output voltage levels that occur with the output load.

**Fig 9. Enable and disable times**

**Table 10. Measurement points**

| Type       | Input       | Output      |                  |                  |
|------------|-------------|-------------|------------------|------------------|
|            | $V_M$       | $V_M$       | $V_X$            | $V_Y$            |
| 74AHC1G66  | $0.5V_{CC}$ | $0.5V_{CC}$ | $V_{OL} + 0.3 V$ | $V_{OH} - 0.3 V$ |
| 74AHCT1G66 | 1.5 V       | 1.5 V       | $V_{OL} + 0.3 V$ | $V_{OH} - 0.3 V$ |

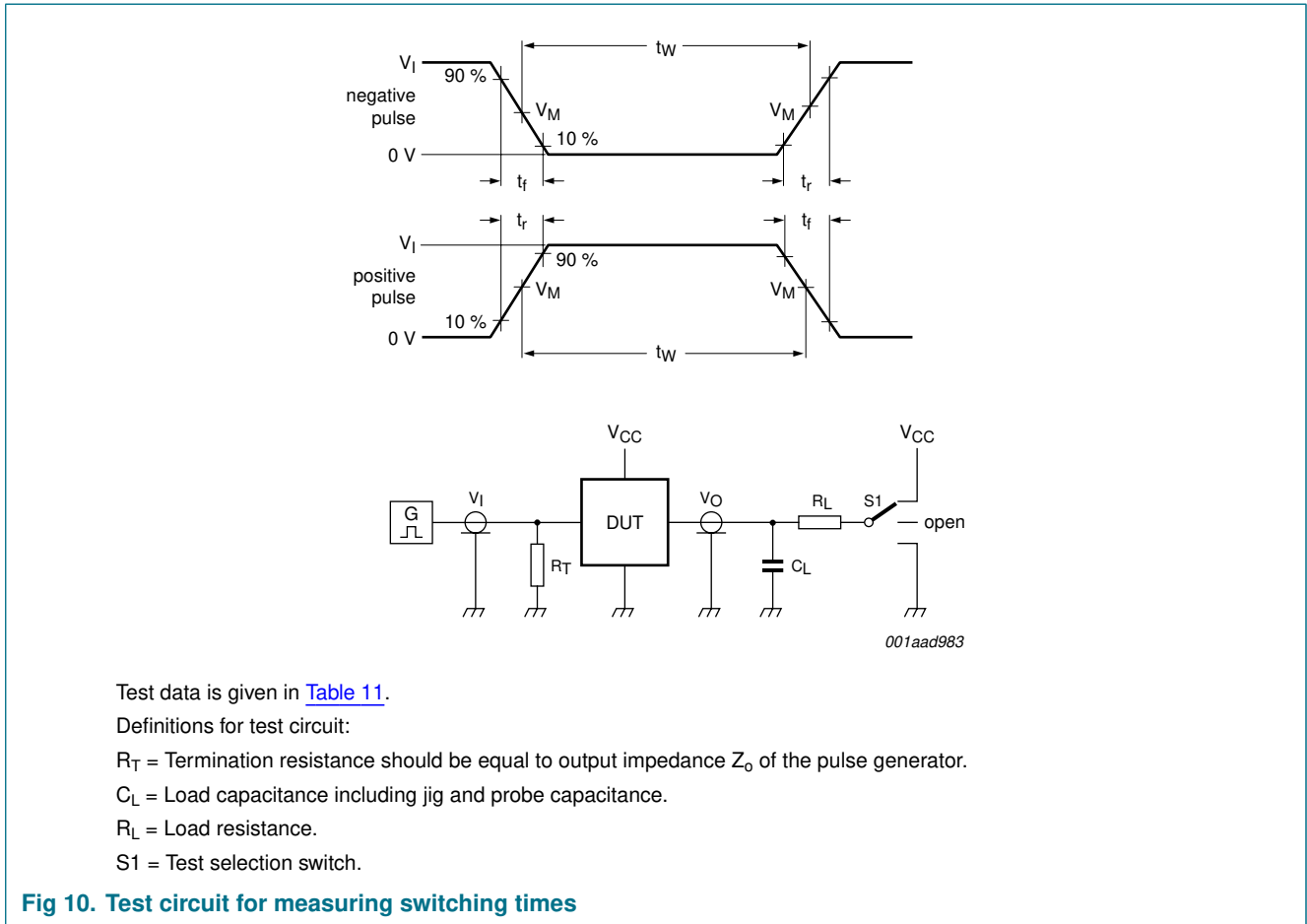

**Table 11. Test data**

| Type       | Input           |            | Load         |              | S1 position        |                    |                    |
|------------|-----------------|------------|--------------|--------------|--------------------|--------------------|--------------------|
|            | $V_I$           | $t_r, t_f$ | $C_L$        | $R_L$        | $t_{PHL}, t_{PLH}$ | $t_{PZH}, t_{PHZ}$ | $t_{PZL}, t_{PLZ}$ |
| 74AHC1G66  | GND to $V_{CC}$ | 3 ns       | 15 pF, 50 pF | 1 k $\Omega$ | open               | GND                | $V_{CC}$           |
| 74AHCT1G66 | GND to 3 V      | 3 ns       | 15 pF, 50 pF | 1 k $\Omega$ | open               | GND                | $V_{CC}$           |

## 11.2 Additional dynamic characteristics

**Table 12. Additional dynamic characteristics for 74AHC1G66 and 74AHCT1G66**

$GND = 0 V$ ;  $t_r = t_f = 3.0 ns$ ;  $C_L = 50 pF$ ; unless otherwise specified. All typical values are measured at  $T_{amb} = 25^\circ C$ .

| Symbol | Parameter                 | Conditions  | Min | Typ   | Max | Unit |  |
|--------|---------------------------|---|-----|-------|-----|------|--|
| THD    | total harmonic distortion | $f_i = 1 kHz$ ; $R_L = 10 k\Omega$ ; see <a href="#">Figure 11</a>  |     |       |     |      |  |
|        |                           | $V_{CC} = 3.0 V$ to $3.6 V$   | -   | 0.025 | -   | %    |  |
|        |                           | $V_{CC} = 4.5 V$ to $5.5 V$   | -   | 0.015 | -   | %    |  |
|        |                           | $f_i = 10 kHz$ ; $R_L = 10 k\Omega$ ; see <a href="#">Figure 11</a> |     |       |     |      |  |
|        |                           | $V_{CC} = 3.0 V$ to $3.6 V$ ; $V_I = 2.5 V$                         | -   | 0.025 | -   | %    |  |
|        |                           | $V_{CC} = 4.5 V$ to $5.5 V$ ; $V_I = 4.0 V$                         | -   | 0.015 | -   | %    |  |

**Table 12. Additional dynamic characteristics for 74AHC1G66 and 74AHCT1G66 ...continued**  
*GND = 0 V;  $t_r = t_f = 3.0$  ns;  $C_L = 50$  pF; unless otherwise specified. All typical values are measured at  $T_{amb} = 25^\circ\text{C}$ .*

| Symbol                | Parameter                | Conditions   | Min | Typ | Max | Unit |
|-----------------------|--------------------------|--|-----|-----|-----|------|
| $f_{(-3\text{dB})}$   | -3 dB frequency response | $R_L = 50\ \Omega$ ; $C_L = 10\ \text{pF}$ ;<br>see <a href="#">Figure 12</a> and <a href="#">13</a> |     |     |     |      |
|                       |                          | $V_{CC} = 3.0\ \text{V}$ to $3.6\ \text{V}$  | -   | 230 | -   | MHz  |
|                       |                          | $V_{CC} = 4.5\ \text{V}$ to $5.5\ \text{V}$  | -   | 280 | -   | MHz  |
| $\alpha_{\text{iso}}$ | isolation (OFF-state)    | $R_L = 600\ \Omega$ ; $f_i = 1\ \text{MHz}$ ; see <a href="#">Figure 14</a> <a href="#">[1]</a>      |     |     |     |      |
|                       |                          | $V_{CC} = 3.0\ \text{V}$ to $3.6\ \text{V}$ ; $V_I = 2.5\ \text{V}$                                  | -   | -50 | -   | dB   |
|                       |                          | $V_{CC} = 4.5\ \text{V}$ to $5.5\ \text{V}$ ; $V_I = 4.0\ \text{V}$                                  | -   | -50 | -   | dB   |

[1] Adjust input voltage  $V_I$  to 0 dBm level (0 dBm = 1 mW into 50  $\Omega$ ).

### 11.3 Test circuits and graphs

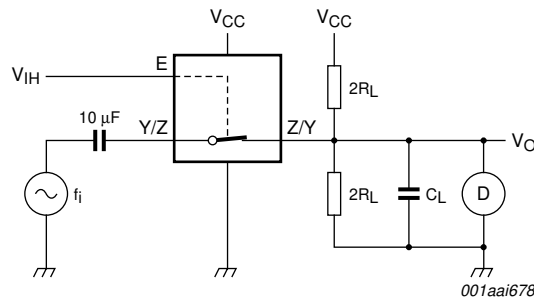

**Test conditions:**

$V_{CC} = 3.0\ \text{V}$  to  $3.6\ \text{V}$ ;  $V_I = 2.5\ \text{V}$  (p-p).

$V_{CC} = 4.5\ \text{V}$  to  $5.5\ \text{V}$ ;  $V_I = 4.0\ \text{V}$  (p-p).

**Fig 11. Test circuit for measuring total harmonic distortion**

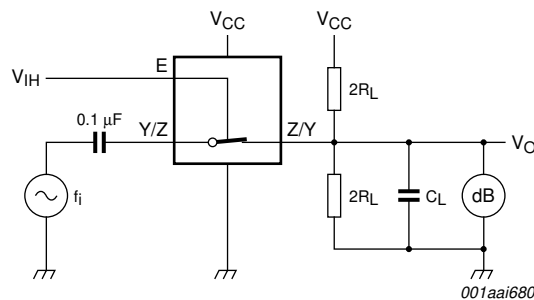

With  $f_i = 1\ \text{MHz}$  adjust the switch input voltage for a 0 dBm level at the switch output, (0 dBm = 1 mW into 50  $\Omega$ ). Then increase the input  $f_i$  frequency until the dB meter reads -3 dB.

**Fig 12. Test circuit for measuring the -3 dB frequency response**

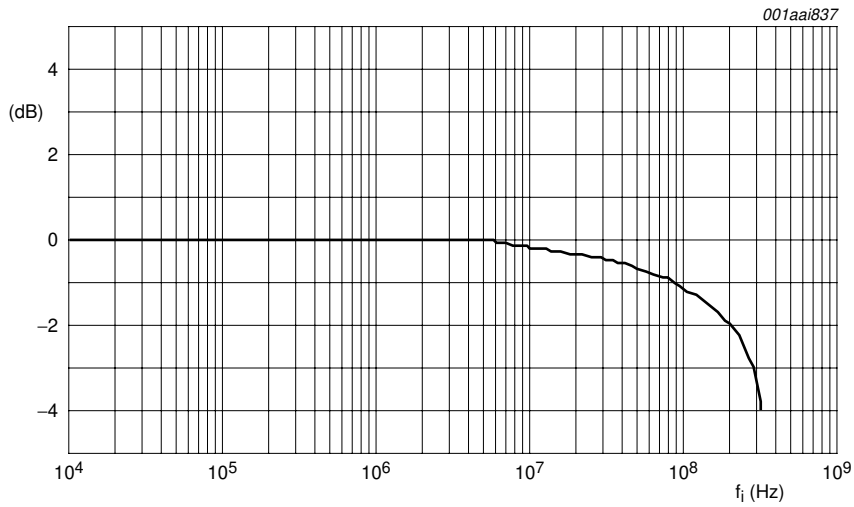

Test conditions:  $V_{CC} = 4.5\text{ V}$ ;  $GND = 0\text{ V}$ ;  $R_L = 50\ \Omega$ ;  $R_{SOURCE} = 1\text{ k}\Omega$ .

**Fig 13. Typical -3 dB frequency response**

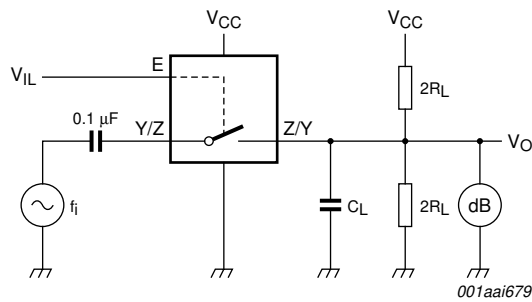

Adjust the switch input voltage for a 0 dBm level (0 dBm = 1 mW into 600  $\Omega$ ).

**Fig 14. Test circuit for measuring isolation (OFF-state)**

## 12. Package outline

TSSOP5: plastic thin shrink small outline package; 5 leads; body width 1.25 mm

SOT353-1

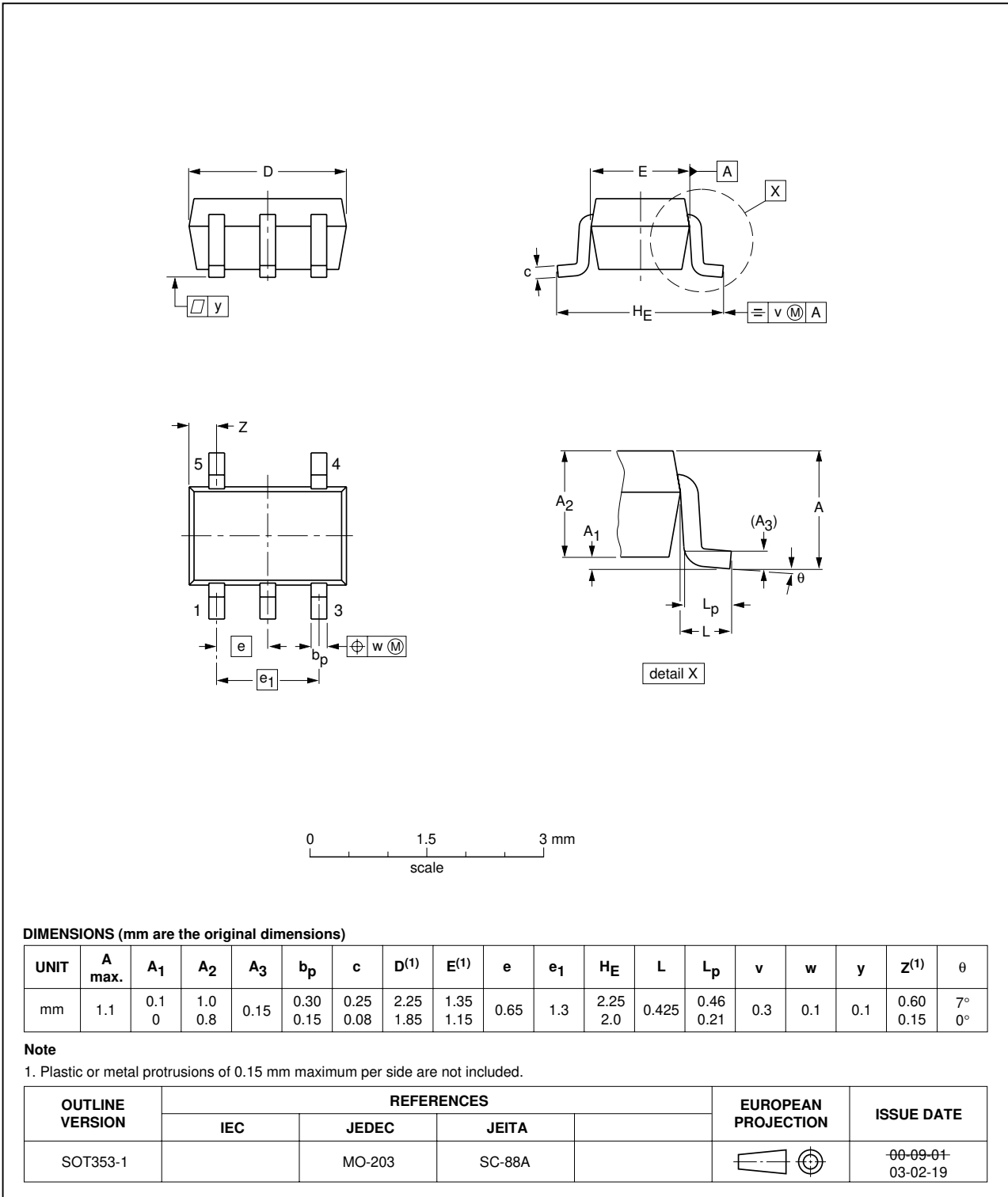

Fig 15. Package outline SOT353-1 (TSSOP5)

Plastic surface-mounted package; 5 leads

SOT753

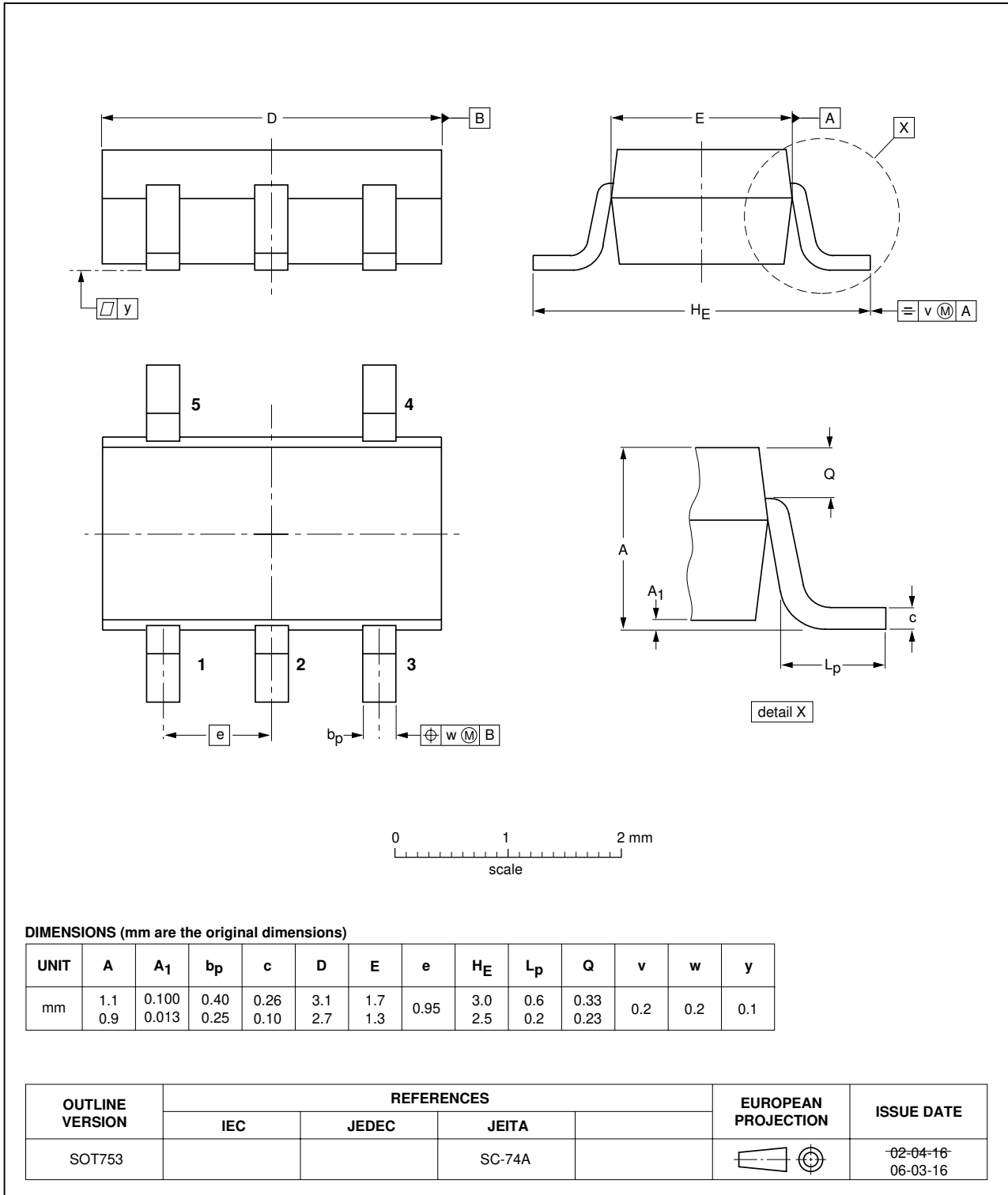

Fig 16. Package outline SOT753 (SC-74A)

## 13. Abbreviations

**Table 13. Abbreviations**

| Acronym | Description                             |
|---------|---|
| CDM     | Charged Device Model                    |
| CMOS    | Complementary Metal-Oxide Semiconductor |
| DUT     | Device Under Test                       |
| ESD     | ElectroStatic Discharge                 |
| HBM     | Human Body Model                        |
| MM      | Machine Model                           |

## 14. Revision history

**Table 14. Revision history**

| Document ID      | Release date   | Data sheet status     | Change notice | Supersedes       |
|------------------|--|-----------------------|---------------|------------------|
| 74AHC_AHCT1G66_4 | 20081218   | Product data sheet    | -             | 74AHC_AHCT1G66_3 |
| Modifications:   | <ul style="list-style-type: none"> <li>The format of this data sheet has been redesigned to comply with the new identity guidelines of NXP Semiconductors.</li> <li>Legal texts have been adapted to the new company name where appropriate.</li> <li>Package SOT353 changed to SOT353-1 in <a href="#">Table 1</a> and <a href="#">Figure 15</a>.</li> <li>Quick Reference Data and Soldering sections removed.</li> <li><a href="#">Section 2 "Features"</a> updated.</li> </ul> |                       |               |                  |
| 74AHC_AHCT1G66_3 | 20020606   | Product specification | -             | 74AHC_AHCT1G66_2 |
| 74AHC_AHCT1G66_2 | 20020215   | Product specification | -             | 74AHC_AHCT1G66_1 |
| 74AHC_AHCT1G66_1 | 20010129   | Product specification | -             | -                |



## 15. Legal information

### 15.1 Data sheet status

| Document status <sup>[1][2]</sup> | Product status <sup>[3]</sup> | Definition  |
|-----------------------------------|-------------------------------|---|
| Objective [short] data sheet      | Development                   | This document contains data from the objective specification for product development. |
| Preliminary [short] data sheet    | Qualification                 | This document contains data from the preliminary specification.                       |
| Product [short] data sheet        | Production                    | This document contains the product specification.                                     |

[1] Please consult the most recently issued document before initiating or completing a design.

[2] The term 'short data sheet' is explained in section "Definitions".

[3] The product status of device(s) described in this document may have changed since this document was published and may differ in case of multiple devices. The latest product status information is available on the Internet at URL <http://www.nxp.com>.

### 15.2 Definitions

**Draft** — The document is a draft version only. The content is still under internal review and subject to formal approval, which may result in modifications or additions. NXP Semiconductors does not give any representations or warranties as to the accuracy or completeness of information included herein and shall have no liability for the consequences of use of such information.

**Short data sheet** — A short data sheet is an extract from a full data sheet with the same product type number(s) and title. A short data sheet is intended for quick reference only and should not be relied upon to contain detailed and full information. For detailed and full information see the relevant full data sheet, which is available on request via the local NXP Semiconductors sales office. In case of any inconsistency or conflict with the short data sheet, the full data sheet shall prevail.

### 15.3 Disclaimers

**General** — Information in this document is believed to be accurate and reliable. However, NXP Semiconductors does not give any representations or warranties, expressed or implied, as to the accuracy or completeness of such information and shall have no liability for the consequences of use of such information.

**Right to make changes** — NXP Semiconductors reserves the right to make changes to information published in this document, including without limitation specifications and product descriptions, at any time and without notice. This document supersedes and replaces all information supplied prior to the publication hereof.

**Suitability for use** — NXP Semiconductors products are not designed, authorized or warranted to be suitable for use in medical, military, aircraft, space or life support equipment, nor in applications where failure or

malfunction of an NXP Semiconductors product can reasonably be expected to result in personal injury, death or severe property or environmental damage. NXP Semiconductors accepts no liability for inclusion and/or use of NXP Semiconductors products in such equipment or applications and therefore such inclusion and/or use is at the customer's own risk.

**Applications** — Applications that are described herein for any of these products are for illustrative purposes only. NXP Semiconductors makes no representation or warranty that such applications will be suitable for the specified use without further testing or modification.

**Limiting values** — Stress above one or more limiting values (as defined in the Absolute Maximum Ratings System of IEC 60134) may cause permanent damage to the device. Limiting values are stress ratings only and operation of the device at these or any other conditions above those given in the Characteristics sections of this document is not implied. Exposure to limiting values for extended periods may affect device reliability.

**Terms and conditions of sale** — NXP Semiconductors products are sold subject to the general terms and conditions of commercial sale, as published at <http://www.nxp.com/profile/terms>, including those pertaining to warranty, intellectual property rights infringement and limitation of liability, unless explicitly otherwise agreed to in writing by NXP Semiconductors. In case of any inconsistency or conflict between information in this document and such terms and conditions, the latter will prevail.

**No offer to sell or license** — Nothing in this document may be interpreted or construed as an offer to sell products that is open for acceptance or the grant, conveyance or implication of any license under any copyrights, patents or other industrial or intellectual property rights.

### 15.4 Trademarks

Notice: All referenced brands, product names, service names and trademarks are the property of their respective owners.

## 16. Contact information

For more information, please visit: <http://www.nxp.com>

For sales office addresses, please send an email to: [salesaddresses@nxp.com](mailto:salesaddresses@nxp.com)

## 17. Contents

|           |   |           |
|-----------|---|-----------|
| <b>1</b>  | <b>General description</b> .....              | <b>1</b>  |
| <b>2</b>  | <b>Features</b> .....                         | <b>1</b>  |
| <b>3</b>  | <b>Ordering information</b> .....             | <b>1</b>  |
| <b>4</b>  | <b>Marking</b> .....                          | <b>2</b>  |
| <b>5</b>  | <b>Functional diagram</b> .....               | <b>2</b>  |
| <b>6</b>  | <b>Pinning information</b> .....              | <b>2</b>  |
| 6.1       | Pinning .....                                 | 2         |
| 6.2       | Pin description .....                         | 3         |
| <b>7</b>  | <b>Functional description</b> .....           | <b>3</b>  |
| <b>8</b>  | <b>Limiting values</b> .....                  | <b>3</b>  |
| <b>9</b>  | <b>Recommended operating conditions</b> ..... | <b>3</b>  |
| <b>10</b> | <b>Static characteristics</b> .....           | <b>4</b>  |
| 10.1      | Test circuits .....                           | 5         |
| 10.2      | ON resistance .....                           | 6         |
| 10.3      | ON resistance test circuit and graphs .....   | 6         |
| <b>11</b> | <b>Dynamic characteristics</b> .....          | <b>7</b>  |
| 11.1      | Waveforms and test circuit .....              | 8         |
| 11.2      | Additional dynamic characteristics .....      | 10        |
| 11.3      | Test circuits and graphs .....                | 11        |
| <b>12</b> | <b>Package outline</b> .....                  | <b>13</b> |
| <b>13</b> | <b>Abbreviations</b> .....                    | <b>15</b> |
| <b>14</b> | <b>Revision history</b> .....                 | <b>15</b> |
| <b>15</b> | <b>Legal information</b> .....                | <b>16</b> |
| 15.1      | Data sheet status .....                       | 16        |
| 15.2      | Definitions .....                             | 16        |
| 15.3      | Disclaimers .....                             | 16        |
| 15.4      | Trademarks .....                              | 16        |
| <b>16</b> | <b>Contact information</b> .....              | <b>16</b> |
| <b>17</b> | <b>Contents</b> .....                         | <b>17</b> |

Please be aware that important notices concerning this document and the product(s) described herein, have been included in section 'Legal information'.



© NXP B.V. 2008.

All rights reserved.

For more information, please visit: <http://www.nxp.com>

For sales office addresses, please send an email to: [salesaddresses@nxp.com](mailto:salesaddresses@nxp.com)

Date of release: 18 December 2008

Document identifier: 74AHC\_AHCT1G66\_4