



Chipsmall Limited consists of a professional team with an average of over 10 year of expertise in the distribution of electronic components. Based in Hongkong, we have already established firm and mutual-benefit business relationships with customers from,Europe,America and south Asia,supplying obsolete and hard-to-find components to meet their specific needs.

With the principle of “Quality Parts,Customers Priority,Honest Operation,and Considerate Service”,our business mainly focus on the distribution of electronic components. Line cards we deal with include Microchip,ALPS,ROHM,Xilinx,Pulse,ON,Everlight and Freescale. Main products comprise IC,Modules,Potentiometer,IC Socket,Relay,Connector.Our parts cover such applications as commercial,industrial, and automotives areas.

We are looking forward to setting up business relationship with you and hope to provide you with the best service and solution. Let us make a better world for our industry!



Contact us

Tel: +86-755-8981 8866 Fax: +86-755-8427 6832

Email & Skype: info@chipsmall.com Web: www.chipsmall.com

Address: A1208, Overseas Decoration Building, #122 Zhenhua RD., Futian, Shenzhen, China



Important notice

Dear Customer,

On 7 February 2017 the former NXP Standard Product business became a new company with the tradename **Nexperia**. Nexperia is an industry leading supplier of Discrete, Logic and PowerMOS semiconductors with its focus on the automotive, industrial, computing, consumer and wearable application markets

In data sheets and application notes which still contain NXP or Philips Semiconductors references, use the references to Nexperia, as shown below.

Instead of <http://www.nxp.com>, <http://www.philips.com/> or <http://www.semiconductors.philips.com/>, use <http://www.nexperia.com>

Instead of sales.addresses@www.nxp.com or sales.addresses@www.semiconductors.philips.com, use salesaddresses@nexperia.com (email)

Replace the copyright notice at the bottom of each page or elsewhere in the document, depending on the version, as shown below:

- © NXP N.V. (year). All rights reserved or © Koninklijke Philips Electronics N.V. (year). All rights reserved

Should be replaced with:

- © **Nexperia B.V. (year). All rights reserved.**

If you have any questions related to the data sheet, please contact our nearest sales office via e-mail or telephone (details via salesaddresses@nexperia.com). Thank you for your cooperation and understanding,

Kind regards,

Team Nexperia

74AHC373; 74AHCT373

Octal D-type transparent latch; 3-state

Rev. 03 — 20 May 2008

Product data sheet

1. General description

The 74AHC373; 74AHCT373 is a high-speed Si-gate CMOS device and is pin compatible with Low-power Schottky TTL (LSTTL). It is specified in compliance with JEDEC standard No. 7-A.

The 74AHC373; 74AHCT373 consists of eight D-type transparent latches featuring separate D-type inputs for each latch and 3-state true outputs for bus oriented applications. A latch enable input (LE) and an output enable input (\overline{OE}) are common to all latches.

When pin LE is HIGH, data at the Dn inputs enters the latches. In this condition the latches are transparent, i.e. a latch output will change state each time its corresponding Dn input changes. When pin LE is LOW, the latches store the information that is present at the Dn inputs, after a set-up time preceding the HIGH-to-LOW transition of LE.

When pin \overline{OE} is LOW, the contents of the 8 latches are available at the outputs. When pin \overline{OE} is HIGH, the outputs go to the high-impedance OFF-state. Operation of the \overline{OE} input does not affect the state of the latches.

The 74AHC373; 74AHCT373 is functionally identical to the 74AHC573; 74AHCT573, but has a different pin arrangement.

2. Features

- Balanced propagation delays
- All inputs have a Schmitt-trigger action
- Common 3-state output enable input
- Inputs accepts voltages higher than V_{CC}
- Functionally identical to the 74AHC573; 74AHCT573
- Input levels:
 - ◆ For 74AHC373: CMOS input level
 - ◆ For 74AHCT373: TTL input level
- ESD protection:
 - ◆ HBM EIA/JESD22-A114E exceeds 2000 V
 - ◆ MM EIA/JESD22-A115-A exceeds 200 V
 - ◆ CDM EIA/JESD22-C101C exceeds 1000 V
- Multiple package options
- Specified from $-40\text{ }^{\circ}\text{C}$ to $+85\text{ }^{\circ}\text{C}$ and from $-40\text{ }^{\circ}\text{C}$ to $+125\text{ }^{\circ}\text{C}$

3. Ordering information

Table 1. Ordering information

Type number	Package			Version
	Temperature range	Name	Description	
74AHC373				
74AHC373D	-40 °C to +125 °C	SO20	plastic small outline package; 20 leads; body width 7.5 mm	SOT163-1
74AHC373PW	-40 °C to +125 °C	TSSOP20	plastic thin shrink small outline package; 20 leads; body width 4.4 mm	SOT360-1
74AHCT373				
74AHCT373D	-40 °C to +125 °C	SO20	plastic small outline package; 20 leads; body width 7.5 mm	SOT163-1
74AHCT373PW	-40 °C to +125 °C	TSSOP20	plastic thin shrink small outline package; 20 leads; body width 4.4 mm	SOT360-1

4. Functional diagram

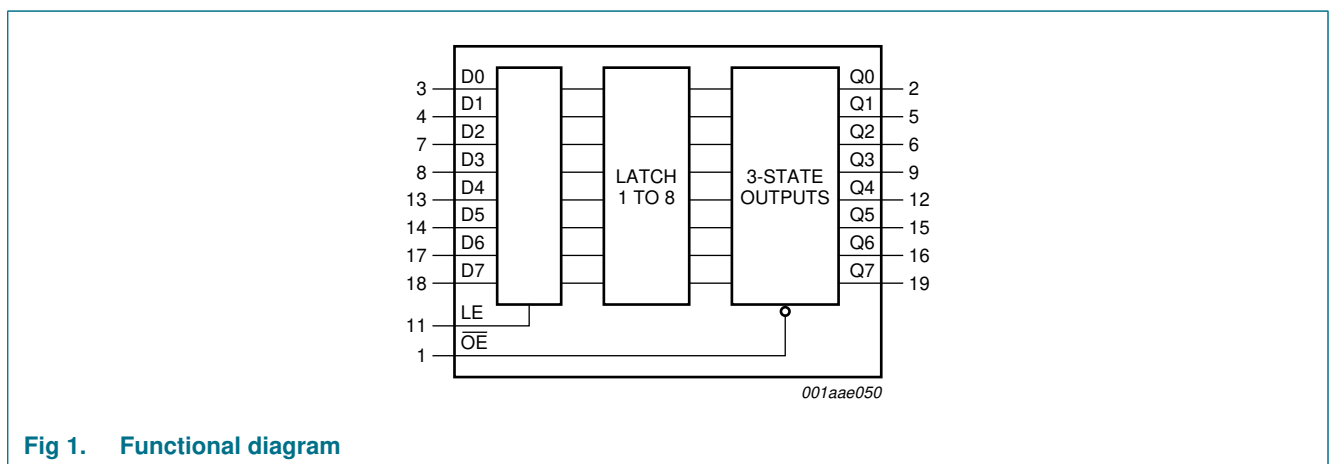

Fig 1. Functional diagram

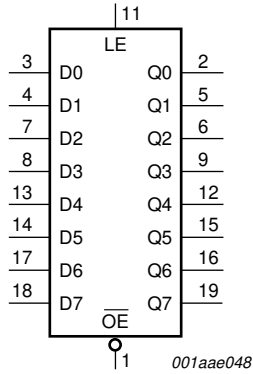

Fig 2. Logic symbol

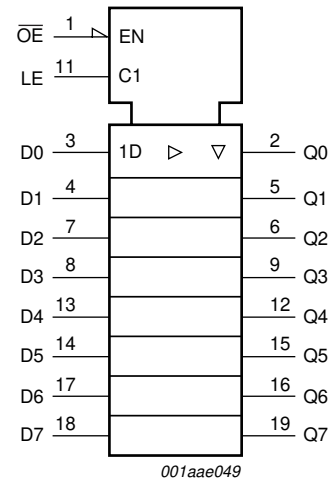

Fig 3. IEC logic symbol

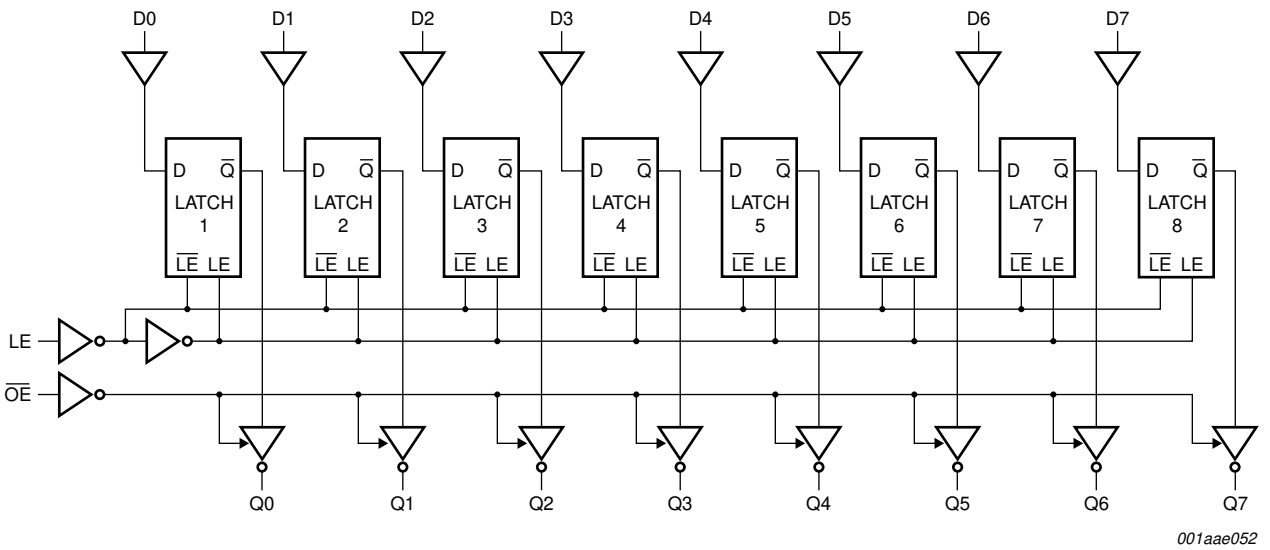

Fig 4. Logic diagram

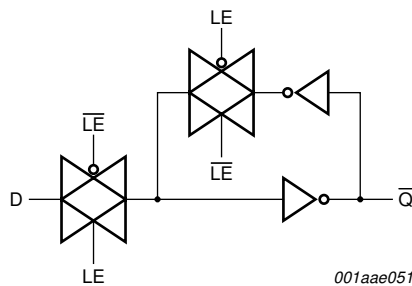
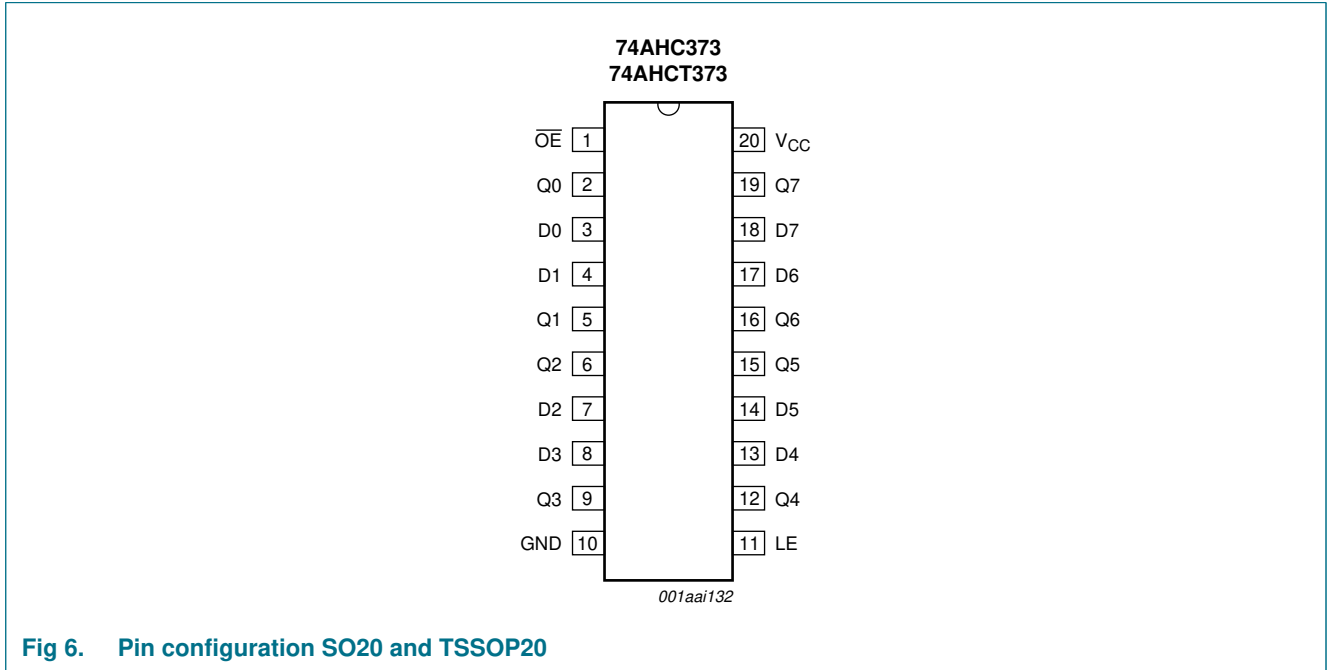

Fig 5. Logic diagram (one latch)

5. Pinning information

5.1 Pinning



5.2 Pin description

Table 2. Pin description

Symbol	Pin	Description
\overline{OE}	1	3-state output enable input (active LOW)
Q0	2	3-state latch output
D0	3	data input
D1	4	data input
Q1	5	3-state latch output
Q2	6	3-state latch output
D2	7	data input
D3	8	data input
Q3	9	3-state latch output
GND	10	ground (0 V)
LE	11	latch enable input (active HIGH)
Q4	12	3-state latch output
D4	13	data input
D5	14	data input
Q5	15	3-state latch output
Q6	16	3-state latch output
D6	17	data input

Table 2. Pin description ...continued

Symbol	Pin	Description
D7	18	data input
Q7	19	3-state latch output
V _{CC}	20	supply voltage

6. Functional description

Table 3. Function table^[1]

Operating mode	Control		Input	Internal latch	Output
	OE	LE	Dn		Q0 to Q7
Enable and read register (transparent mode)	L	H	L	L	L
			H	H	H
Latch and read register	L	L	l	L	L
			h	H	H
Latch register and disable outputs	H	X	X	X	Z
			X	X	Z

- [1] H = HIGH voltage level;
 h = HIGH voltage level one set-up time prior to the HIGH-to-LOW LE transition;
 L = LOW voltage level;
 l = LOW voltage level one set-up time prior to the HIGH-to-LOW LE transition;
 X = don't care;
 Z = high-impedance OFF-state.

7. Limiting values

Table 4. Limiting values

In accordance with the Absolute Maximum Rating System (IEC 60134). Voltages are referenced to GND (ground = 0 V).

Symbol	Parameter	Conditions	Min	Max	Unit
V _{CC}	supply voltage		-0.5	+7.0	V
V _I	input voltage		-0.5	+7.0	V
I _{IK}	input clamping current	V _I < -0.5 V	[1] -20	-	mA
I _{OK}	output clamping current	V _O < -0.5 V or V _O > V _{CC} + 0.5 V	[1] -20	+20	mA
I _O	output current	V _O = -0.5 V to (V _{CC} + 0.5 V)	-25	+25	mA
I _{CC}	supply current		-	+75	mA
I _{GND}	ground current		-75	-	mA
T _{stg}	storage temperature		-65	+150	°C
P _{tot}	total power dissipation	T _{amb} = -40 °C to +125 °C	[2] -	500	mW

- [1] The input and output voltage ratings may be exceeded if the input and output current ratings are observed.
 [2] For SO20 packages: above 70 °C the value of P_{tot} derates linearly at 8 mW/K.
 For TSSOP20 packages: above 60 °C the value of P_{tot} derates linearly at 5.5 mW/K.

8. Recommended operating conditions

Table 5. Operating conditions

Symbol	Parameter	Conditions	Min	Typ	Max	Unit
74AHC373						
V_{CC}	supply voltage		2.0	5.0	5.5	V
V_I	input voltage		0	-	5.5	V
V_O	output voltage		0	-	V_{CC}	V
T_{amb}	ambient temperature		-40	+25	+125	°C
$\Delta t/\Delta V$	input transition rise and fall rate	$V_{CC} = 3.0\text{ V to }3.6\text{ V}$	-	-	100	ns/V
		$V_{CC} = 4.5\text{ V to }5.5\text{ V}$	-	-	20	ns/V
74AHCT373						
V_{CC}	supply voltage		4.5	5.0	5.5	V
V_I	input voltage		0	-	5.5	V
V_O	output voltage		0	-	V_{CC}	V
T_{amb}	ambient temperature		-40	+25	+125	°C
$\Delta t/\Delta V$	input transition rise and fall rate	$V_{CC} = 4.5\text{ V to }5.5\text{ V}$	-	-	20	ns/V

9. Static characteristics

Table 6. Static characteristics

At recommended operating conditions; voltages are referenced to GND (ground = 0 V).

Symbol	Parameter	Conditions	25 °C			-40 °C to +85 °C		-40 °C to +125 °C		Unit
			Min	Typ	Max	Min	Max	Min	Max	
74AHC373										
V_{IH}	HIGH-level input voltage	$V_{CC} = 2.0\text{ V}$	1.5	-	-	1.5	-	1.5	-	V
		$V_{CC} = 3.0\text{ V}$	2.1	-	-	2.1	-	2.1	-	V
		$V_{CC} = 5.5\text{ V}$	3.85	-	-	3.85	-	3.85	-	V
V_{IL}	LOW-level input voltage	$V_{CC} = 2.0\text{ V}$	-	-	0.5	-	0.5	-	0.5	V
		$V_{CC} = 3.0\text{ V}$	-	-	0.9	-	0.9	-	0.9	V
		$V_{CC} = 5.5\text{ V}$	-	-	1.65	-	1.65	-	1.65	V
V_{OH}	HIGH-level output voltage	$V_I = V_{IH}$ or V_{IL}								
		$I_O = -50\ \mu\text{A}; V_{CC} = 2.0\text{ V}$	1.9	2.0	-	1.9	-	1.9	-	V
		$I_O = -50\ \mu\text{A}; V_{CC} = 3.0\text{ V}$	2.9	3.0	-	2.9	-	2.9	-	V
		$I_O = -50\ \mu\text{A}; V_{CC} = 4.5\text{ V}$	4.4	4.5	-	4.4	-	4.4	-	V
		$I_O = -4.0\text{ mA}; V_{CC} = 3.0\text{ V}$	2.58	-	-	2.48	-	2.40	-	V
		$I_O = -8.0\text{ mA}; V_{CC} = 4.5\text{ V}$	3.94	-	-	3.80	-	3.70	-	V
V_{OL}	LOW-level output voltage	$V_I = V_{IH}$ or V_{IL}								
		$I_O = 50\ \mu\text{A}; V_{CC} = 2.0\text{ V}$	-	0	0.1	-	0.1	-	0.1	V
		$I_O = 50\ \mu\text{A}; V_{CC} = 3.0\text{ V}$	-	0	0.1	-	0.1	-	0.1	V
		$I_O = 50\ \mu\text{A}; V_{CC} = 4.5\text{ V}$	-	0	0.1	-	0.1	-	0.1	V
		$I_O = 4.0\text{ mA}; V_{CC} = 3.0\text{ V}$	-	-	0.36	-	0.44	-	0.55	V
		$I_O = 8.0\text{ mA}; V_{CC} = 4.5\text{ V}$	-	-	0.36	-	0.44	-	0.55	V

Table 6. Static characteristics ...continued

At recommended operating conditions; voltages are referenced to GND (ground = 0 V).

Symbol	Parameter	Conditions	25 °C			-40 °C to +85 °C		-40 °C to +125 °C		Unit
			Min	Typ	Max	Min	Max	Min	Max	
I_{OZ}	OFF-state output current	$V_I = V_{IH}$ or V_{IL} ; $V_O = V_{CC}$ or GND; $V_{CC} = 5.5$ V	-	-	± 0.2 5	-	± 2.5	-	± 10.0	μA
I_I	input leakage current	$V_I = V_{CC}$ or GND; $V_{CC} = 0$ V to 5.5 V	-	-	0.1	-	1.0	-	2.0	μA
I_{CC}	supply current	$V_I = V_{CC}$ or GND; $I_O = 0$ A; $V_{CC} = 5.5$ V	-	-	4.0	-	40	-	80	μA
C_I	input capacitance	$V_I = V_{CC}$ or GND	-	3	10	-	10	-	10	pF
C_O	output capacitance		-	4	-	-	-	-	10	pF

74AHCT373

V_{IH}	HIGH-level input voltage	$V_{CC} = 4.5$ V to 5.5 V	2.0	-	-	2.0	-	2.0	-	V
V_{IL}	LOW-level input voltage	$V_{CC} = 4.5$ V to 5.5 V	-	-	0.8	-	0.8	-	0.8	V
V_{OH}	HIGH-level output voltage	$V_I = V_{IH}$ or V_{IL} ; $V_{CC} = 4.5$ V								
		$I_O = -50$ μA	4.4	4.5	-	4.4	-	4.4	-	V
		$I_O = -8.0$ mA	3.94	-	-	3.80	-	3.70	-	V
V_{OL}	LOW-level output voltage	$V_I = V_{IH}$ or V_{IL} ; $V_{CC} = 4.5$ V								
		$I_O = 50$ μA	-	0	0.1	-	0.1	-	0.1	V
		$I_O = 8.0$ mA	-	-	0.36	-	0.44	-	0.55	V
I_{OZ}	OFF-state output current	$V_I = V_{IH}$ or V_{IL} ; $V_O = V_{CC}$ or GND per input pin; other inputs at V_{CC} or GND; $I_O = 0$ A; $V_{CC} = 5.5$ V	-	-	± 0.2 5	-	± 2.5	-	± 10.0	μA
I_I	input leakage current	$V_I = 5.5$ V or GND; $V_{CC} = 0$ V to 5.5 V	-	-	0.1	-	1.0	-	2.0	μA
I_{CC}	supply current	$V_I = V_{CC}$ or GND; $I_O = 0$ A; $V_{CC} = 5.5$ V	-	-	4.0	-	40	-	80	μA
ΔI_{CC}	additional supply current	per input pin; $V_I = V_{CC} - 2.1$ V; other pins at V_{CC} or GND; $I_O = 0$ A; $V_{CC} = 4.5$ V to 5.5 V	-	-	1.35	-	1.5	-	1.5	μA
C_I	input capacitance	$V_I = V_{CC}$ or GND	-	3	10	-	10	-	10	pF
C_O	output capacitance		-	4	-	-	-	-	10	pF

10. Dynamic characteristics

Table 7. Dynamic characteristics

Voltages are referenced to GND (ground = 0 V); for test circuit see [Figure 11](#).

Symbol	Parameter	Conditions	25 °C			-40 °C to +85 °C		-40 °C to +125 °C		Unit
			Min	Typ ^[1]	Max	Min	Max	Min	Max	
74AHC373										
t _{pd}	propagation delay	Dn to Qn; see Figure 7 ^[2]								
		V _{CC} = 3.0 V to 3.6 V								
		C _L = 15 pF	-	6.0	11.4	1.0	13.5	1.0	14.5	ns
		C _L = 50 pF	-	7.8	14.9	1.0	17.0	1.0	19.0	ns
		V _{CC} = 4.5 V to 5.5 V								
		C _L = 15 pF	-	4.0	7.2	1.0	8.5	1.0	9.0	ns
		C _L = 50 pF	-	5.3	9.2	1.0	10.5	1.0	11.5	ns
		LE to Qn; see Figure 8 ^[2]								
		V _{CC} = 3.0 V to 3.6 V								
		C _L = 15 pF	-	6.3	11.0	1.0	13.0	1.0	14.0	ns
		C _L = 50 pF	-	8.3	14.5	1.0	16.5	1.0	18.5	ns
		t _{en}	enable time	\overline{OE} to Qn; see Figure 9 ^[3]						
V _{CC} = 3.0 V to 3.6 V										
C _L = 15 pF	-			5.6	11.4	1.0	13.5	1.0	14.5	ns
C _L = 50 pF	-			7.5	14.9	1.0	17.0	1.0	19.0	ns
V _{CC} = 4.5 V to 5.5 V										
C _L = 15 pF	-			3.8	8.1	1.0	9.5	1.0	10.5	ns
t _{dis}	disable time	\overline{OE} to Qn; see Figure 9 ^[4]								
		V _{CC} = 3.0 V to 3.6 V								
		C _L = 15 pF	-	5.6	10.0	1.0	12.0	1.0	13.0	ns
		C _L = 50 pF	-	9.2	13.3	1.0	15.0	1.0	17.0	ns
		V _{CC} = 4.5 V to 5.5 V								
		C _L = 15 pF	-	4.3	7.2	1.0	8.5	1.0	9.5	ns
t _w	pulse width	LE HIGH or LOW; see Figure 8								
		V _{CC} = 3.0 V to 3.6 V	5.0	-	-	5.0	-	5.0	-	ns
		V _{CC} = 4.5 V to 5.5 V	5.0	-	-	5.0	-	5.0	-	ns
t _{su}	set-up time	Dn to LE; see Figure 10								
		V _{CC} = 3.0 V to 3.6 V	4.0	-	-	4.0	-	4.0	-	ns
		V _{CC} = 4.5 V to 5.5 V	4.0	-	-	4.0	-	4.0	-	ns

Table 7. Dynamic characteristics ...continued

Voltages are referenced to GND (ground = 0 V); for test circuit see [Figure 11](#).

Symbol	Parameter	Conditions	25 °C			-40 °C to +85 °C		-40 °C to +125 °C		Unit
			Min	Typ ^[1]	Max	Min	Max	Min	Max	
t _h	hold time	Dn to LE; see Figure 10								
		V _{CC} = 3.0 V to 3.6 V	1.0	-	-	1.0	-	1.0	-	ns
		V _{CC} = 4.5 V to 5.5 V	1.0	-	-	1.0	-	1.0	-	ns
C _{PD}	power dissipation capacitance	f _i = 1 MHz; V _I = GND to V _{CC}	^[5]	-	10	-	-	-	-	pF
74AHCT373; V_{CC} = 4.5 V to 5.5 V										
t _{pd}	propagation delay	Dn to Qn; see Figure 7	^[4]							
		C _L = 15 pF	-	4.0	8.5	1.0	9.5	1.0	11.0	ns
		C _L = 50 pF	-	5.2	9.5	1.0	10.5	1.0	12.0	ns
		LE to Qn; see Figure 8								
		C _L = 15 pF	^[4]	-	4.3	12.3	1.0	13.5	1.0	15.5
t _{en}	enable time	\overline{OE} to Qn; see Figure 9								
		C _L = 15 pF	-	4.0	10.9	1.0	12.5	1.0	14.0	ns
		C _L = 50 pF	^[4]	-	5.2	11.9	1.0	13.5	1.0	15.0
t _{dis}	disable time	\overline{OE} to Qn; see Figure 9								
		C _L = 15 pF	-	4.4	10.2	1.0	11.0	1.0	13.0	ns
		C _L = 50 pF	-	6.5	11.2	1.0	12.0	1.0	14.0	ns
t _w	pulse width	LE HIGH; see Figure 8	^[4]	6.5	-	-	6.5	-	6.5	ns
t _{su}	set-up time	Dn to LE; see Figure 10		3.5	-	-	3.5	-	3.5	ns
t _h	hold time	Dn to LE; see Figure 10		1.5	-	-	1.5	-	1.5	ns
C _{PD}	power dissipation capacitance	f _i = 1 MHz; V _I = GND to V _{CC}	^[5]	-	12	-	-	-	-	pF

[1] Typical values are measured at nominal supply voltage (V_{CC} = 3.3 V and V_{CC} = 5.0 V).

[2] t_{pd} is the same as t_{PHL} and t_{PLH}.

[3] t_{en} is the same as t_{PZH} and t_{PZL}.

[4] t_{dis} is the same as t_{PHZ} and t_{PLZ}.

[5] C_{PD} is used to determine the dynamic power dissipation (P_D in μW).

$$P_D = C_{PD} \times V_{CC}^2 \times f_i \times N + \Sigma(C_L \times V_{CC}^2 \times f_o) \text{ where:}$$

f_i = input frequency in MHz;

f_o = output frequency in MHz;

C_L = output load capacitance in pF;

V_{CC} = supply voltage in V;

N = number of inputs switching;

Σ(C_L × V_{CC}² × f_o) = sum of the outputs.

11. Waveforms

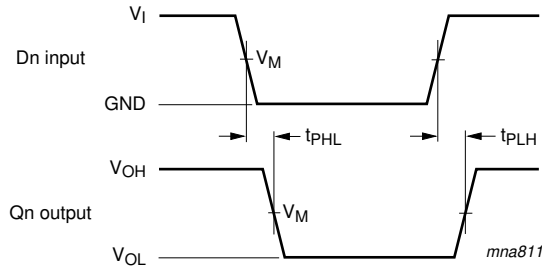

Measurement points are given in [Table 8](#).
 V_{OL} and V_{OH} are typical voltage output levels that occur with the output load.

Fig 7. Data input to output propagation delays

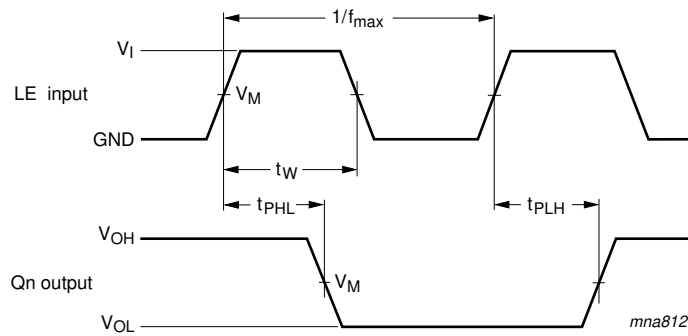

Measurement points are given in [Table 8](#).
 V_{OL} and V_{OH} are typical voltage output levels that occur with the output load.

Fig 8. Latch enable pulse width and input to output propagation delays

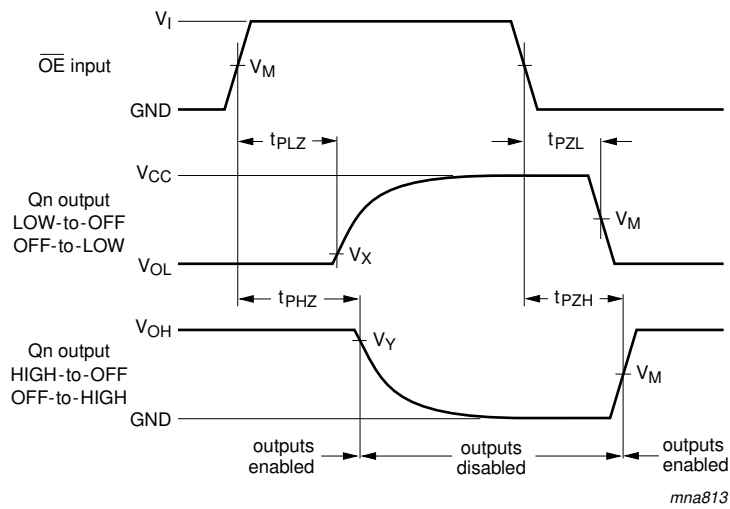

Measurement points are given in [Table 8](#).
 V_{OL} and V_{OH} are typical voltage output levels that occur with the output load.

Fig 9. Enable and disable times

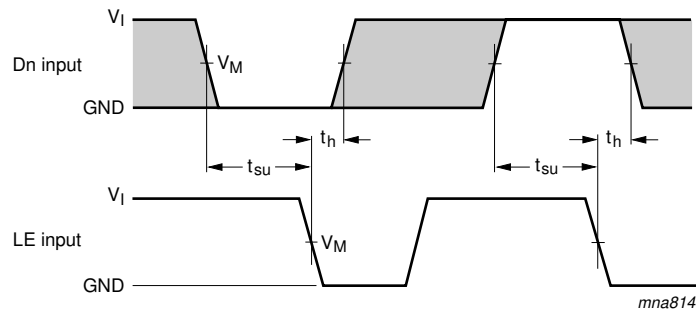

Measurement points are given in [Table 8](#).
 V_{OL} and V_{OH} are typical voltage output levels that occur with the output load.
 The shaded areas indicate when the input is permitted to change for predictable output performance.

Fig 10. Data set-up and hold times

Table 8. Measurement points

Type	Input	Output		
	V_M	V_M	V_X	V_Y
74AHC373	$0.5 \times V_{CC}$	$0.5 \times V_{CC}$	$V_{OL} + 0.3 \text{ V}$	$V_{OH} - 0.3 \text{ V}$
74AHCT373	1.5 V	$0.5 \times V_{CC}$	$V_{OL} + 0.3 \text{ V}$	$V_{OH} - 0.3 \text{ V}$

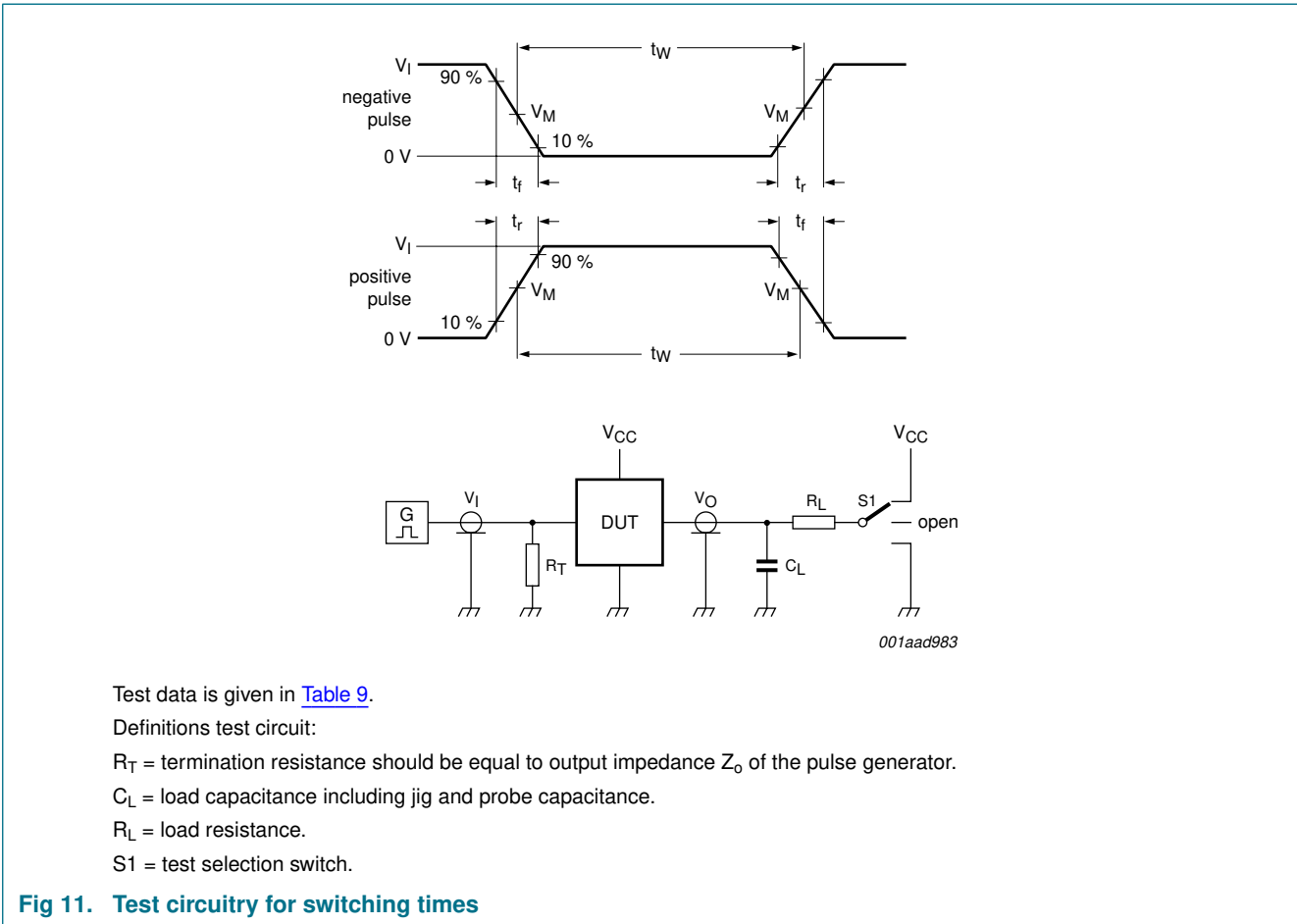

Table 9. Test data

Type	Input		Load		S1 position		
	V_I	t_r, t_f	C_L	R_L	t_{PHL}, t_{PLH}	t_{PZH}, t_{PHZ}	t_{PZL}, t_{PLZ}
74AHC373	V_{CC}	≤ 3.0 ns	15 pF, 50 pF	1 k Ω	open	GND	V_{CC}
74AHCT373	3.0 V	≤ 3.0 ns	15 pF, 50 pF	1 k Ω	open	GND	V_{CC}

12. Package outline

SO20: plastic small outline package; 20 leads; body width 7.5 mm

SOT163-1

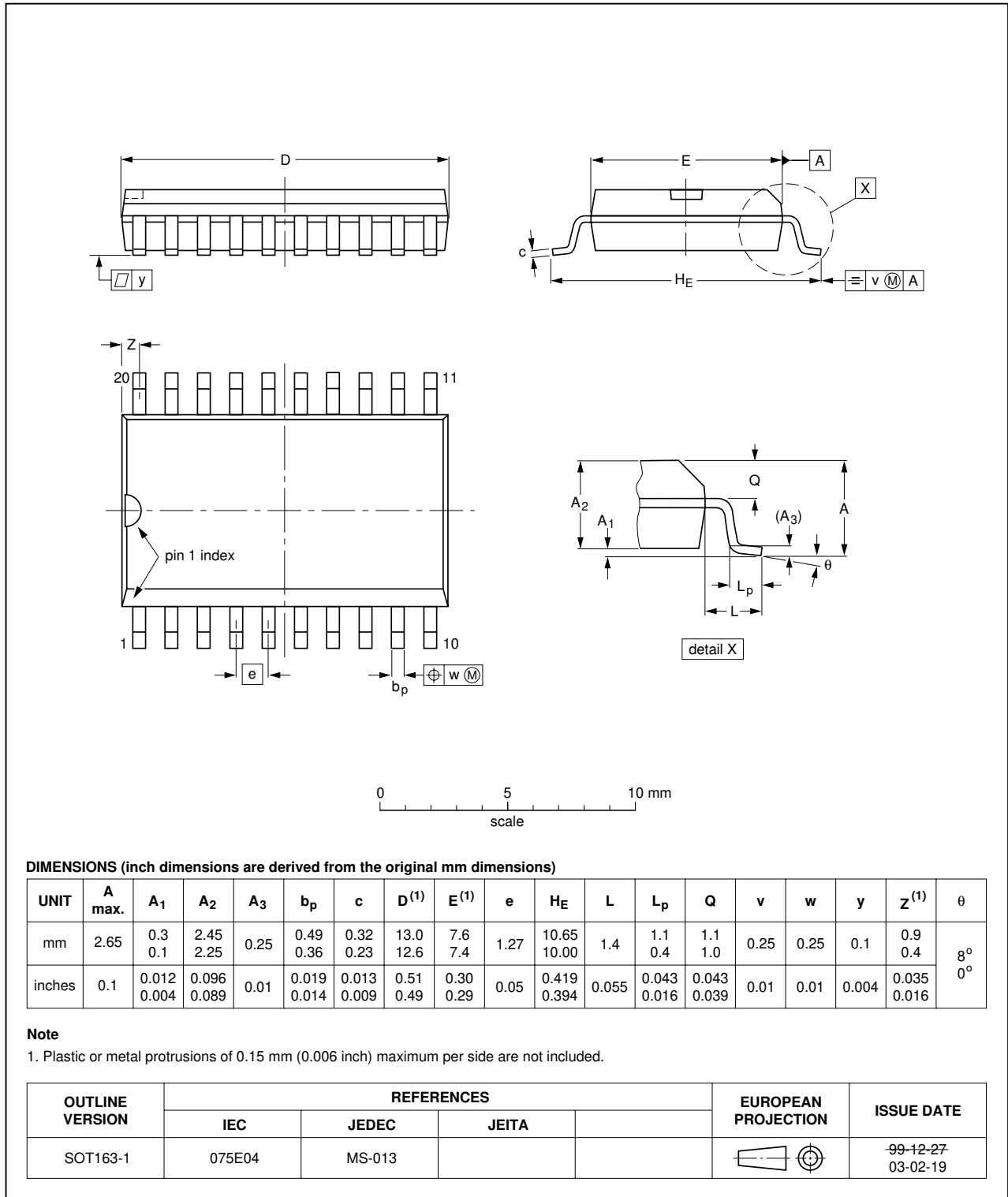

Fig 12. Package outline SOT163-1 (SO20)

TSSOP20: plastic thin shrink small outline package; 20 leads; body width 4.4 mm

SOT360-1

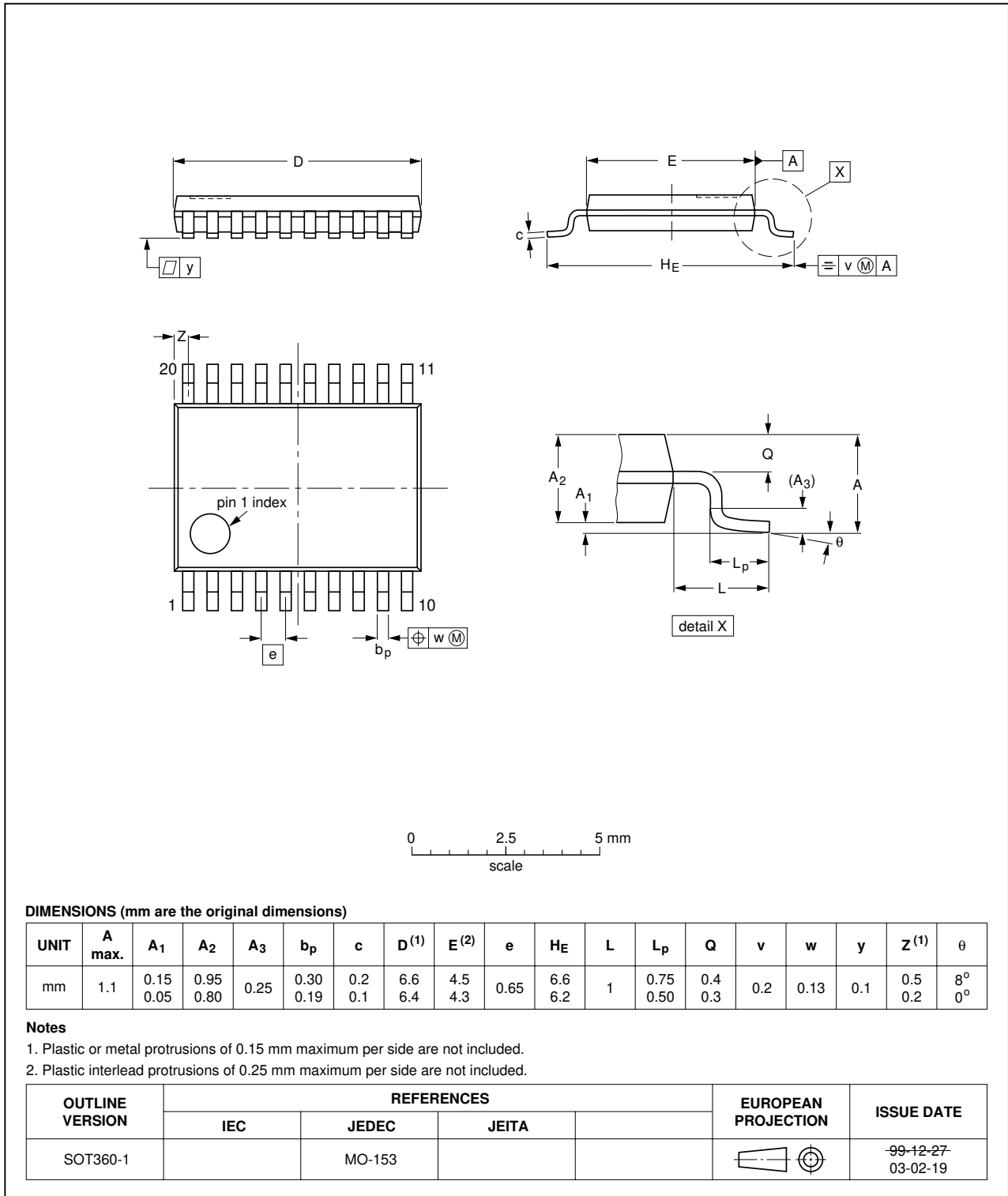

Fig 13. Package outline SOT360-1 (TSSOP20)

13. Abbreviations

Table 10. Abbreviations

Acronym	Description
CDM	Charged Device Model
CMOS	Complementary Metal-Oxide Semiconductor
ESD	ElectroStatic Discharge
HBM	Human Body Model
MM	Machine Model
TTL	Transistor-Transistor Logic

14. Revision history

Table 11. Revision history

Document ID	Release date	Data sheet status	Change notice	Supersedes
74AHC_AHCT373_3	20080520	Product data sheet	-	74AHC_AHCT373_2
Modifications:				
				<ul style="list-style-type: none">• The format of this data sheet has been redesigned to comply with the new identity guidelines of NXP Semiconductors.• Legal texts have been adapted to the new company name where appropriate.• Table 6: conditions for the input leakage current have been changed.
74AHC_AHCT373_2	19991123	Product specification	-	74AHC_AHCT373_1
74AHC_AHCT373_1	19981211	Product specification	-	-

15. Legal information

15.1 Data sheet status

Document status ^{[1][2]}	Product status ^[3]	Definition
Objective [short] data sheet	Development	This document contains data from the objective specification for product development.
Preliminary [short] data sheet	Qualification	This document contains data from the preliminary specification.
Product [short] data sheet	Production	This document contains the product specification.

[1] Please consult the most recently issued document before initiating or completing a design.

[2] The term 'short data sheet' is explained in section "Definitions".

[3] The product status of device(s) described in this document may have changed since this document was published and may differ in case of multiple devices. The latest product status information is available on the Internet at URL <http://www.nxp.com>.

15.2 Definitions

Draft — The document is a draft version only. The content is still under internal review and subject to formal approval, which may result in modifications or additions. NXP Semiconductors does not give any representations or warranties as to the accuracy or completeness of information included herein and shall have no liability for the consequences of use of such information.

Short data sheet — A short data sheet is an extract from a full data sheet with the same product type number(s) and title. A short data sheet is intended for quick reference only and should not be relied upon to contain detailed and full information. For detailed and full information see the relevant full data sheet, which is available on request via the local NXP Semiconductors sales office. In case of any inconsistency or conflict with the short data sheet, the full data sheet shall prevail.

15.3 Disclaimers

General — Information in this document is believed to be accurate and reliable. However, NXP Semiconductors does not give any representations or warranties, expressed or implied, as to the accuracy or completeness of such information and shall have no liability for the consequences of use of such information.

Right to make changes — NXP Semiconductors reserves the right to make changes to information published in this document, including without limitation specifications and product descriptions, at any time and without notice. This document supersedes and replaces all information supplied prior to the publication hereof.

Suitability for use — NXP Semiconductors products are not designed, authorized or warranted to be suitable for use in medical, military, aircraft, space or life support equipment, nor in applications where failure or

malfunction of an NXP Semiconductors product can reasonably be expected to result in personal injury, death or severe property or environmental damage. NXP Semiconductors accepts no liability for inclusion and/or use of NXP Semiconductors products in such equipment or applications and therefore such inclusion and/or use is at the customer's own risk.

Applications — Applications that are described herein for any of these products are for illustrative purposes only. NXP Semiconductors makes no representation or warranty that such applications will be suitable for the specified use without further testing or modification.

Limiting values — Stress above one or more limiting values (as defined in the Absolute Maximum Ratings System of IEC 60134) may cause permanent damage to the device. Limiting values are stress ratings only and operation of the device at these or any other conditions above those given in the Characteristics sections of this document is not implied. Exposure to limiting values for extended periods may affect device reliability.

Terms and conditions of sale — NXP Semiconductors products are sold subject to the general terms and conditions of commercial sale, as published at <http://www.nxp.com/profile/terms>, including those pertaining to warranty, intellectual property rights infringement and limitation of liability, unless explicitly otherwise agreed to in writing by NXP Semiconductors. In case of any inconsistency or conflict between information in this document and such terms and conditions, the latter will prevail.

No offer to sell or license — Nothing in this document may be interpreted or construed as an offer to sell products that is open for acceptance or the grant, conveyance or implication of any license under any copyrights, patents or other industrial or intellectual property rights.

15.4 Trademarks

Notice: All referenced brands, product names, service names and trademarks are the property of their respective owners.

16. Contact information

For more information, please visit: <http://www.nxp.com>

For sales office addresses, please send an email to: salesaddresses@nxp.com

17. Contents

1	General description	1
2	Features	1
3	Ordering information	2
4	Functional diagram	2
5	Pinning information	4
5.1	Pinning	4
5.2	Pin description	4
6	Functional description	5
7	Limiting values	5
8	Recommended operating conditions	6
9	Static characteristics	6
10	Dynamic characteristics	8
11	Waveforms	10
12	Package outline	13
13	Abbreviations	15
14	Revision history	15
15	Legal information	16
15.1	Data sheet status	16
15.2	Definitions	16
15.3	Disclaimers	16
15.4	Trademarks	16
16	Contact information	16
17	Contents	17

Please be aware that important notices concerning this document and the product(s) described herein, have been included in section 'Legal information'.



© NXP B.V. 2008.

All rights reserved.

For more information, please visit: <http://www.nxp.com>

For sales office addresses, please send an email to: salesaddresses@nxp.com

Date of release: 20 May 2008

Document identifier: 74AHC_AHCT373_3