



Chipsmall Limited consists of a professional team with an average of over 10 year of expertise in the distribution of electronic components. Based in Hongkong, we have already established firm and mutual-benefit business relationships with customers from,Europe,America and south Asia,supplying obsolete and hard-to-find components to meet their specific needs.

With the principle of “Quality Parts,Customers Priority,Honest Operation,and Considerate Service”,our business mainly focus on the distribution of electronic components. Line cards we deal with include Microchip,ALPS,ROHM,Xilinx,Pulse,ON,Everlight and Freescale. Main products comprise IC,Modules,Potentiometer,IC Socket,Relay,Connector.Our parts cover such applications as commercial,industrial, and automotives areas.

We are looking forward to setting up business relationship with you and hope to provide you with the best service and solution. Let us make a better world for our industry!



## Contact us

Tel: +86-755-8981 8866 Fax: +86-755-8427 6832

Email & Skype: info@chipsmall.com Web: www.chipsmall.com

Address: A1208, Overseas Decoration Building, #122 Zhenhua RD., Futian, Shenzhen, China





## 3.3V CMOS 16-BIT BUFFER/DRIVER WITH 3-STATE OUTPUTS AND BUS-HOLD

**IDT74ALVCH16244**

### FEATURES:

- 0.5 MICRON CMOS Technology
- Typical  $t_{sk(o)}$  (Output Skew) < 250ps
- ESD > 2000V per MIL-STD-883, Method 3015; > 200V using machine model (C = 200pF, R = 0)
- $V_{cc} = 3.3V \pm 0.3V$ , Normal Range
- $V_{cc} = 2.7V$  to  $3.6V$ , Extended Range
- $V_{cc} = 2.5V \pm 0.2V$
- CMOS power levels (0.4 $\mu$  W typ. static)
- Rail-to-Rail output swing for increased noise margin
- Available in TSSOP package

### DRIVE FEATURES:

- High Output Drivers:  $\pm 24mA$
- Suitable for heavy loads

### APPLICATIONS:

- 3.3V high speed systems
- 3.3V and lower voltage computing systems

### DESCRIPTION:

This 16-bit buffer/driver is built using advanced dual metal CMOS technology. The ALVCH16244 is designed specifically to improve the performance and density of 3-state memory address drivers, clock drivers, and bus-oriented receivers and transmitters. The device can be used as four 4-bit buffers, two 8-bit buffers, or one 16-bit buffer. It provides true outputs and symmetrical active-low output-enable ( $\overline{OE}$ ) inputs.

The ALVCH16244 has been designed with a  $\pm 24mA$  output driver. This driver is capable of driving a moderate to heavy load while maintaining speed performance.

The ALVCH16244 has "bus-hold" which retains the inputs' last state whenever the input bus goes to a high impedance. This prevents floating inputs and eliminates the need for pull-up/down resistors.

### FUNCTIONAL BLOCK DIAGRAM

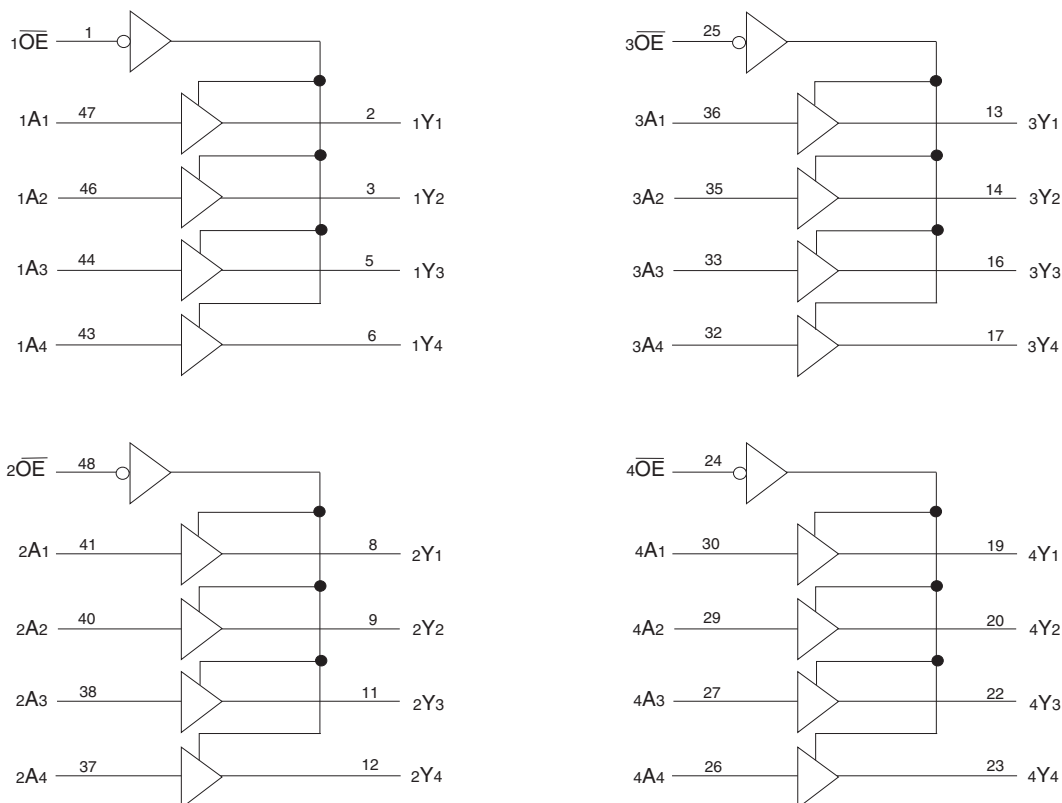

IDT and the IDT logo are registered trademarks of Integrated Device Technology, Inc.

**INDUSTRIAL TEMPERATURE RANGE**

**AUGUST 2016**

## PIN CONFIGURATION

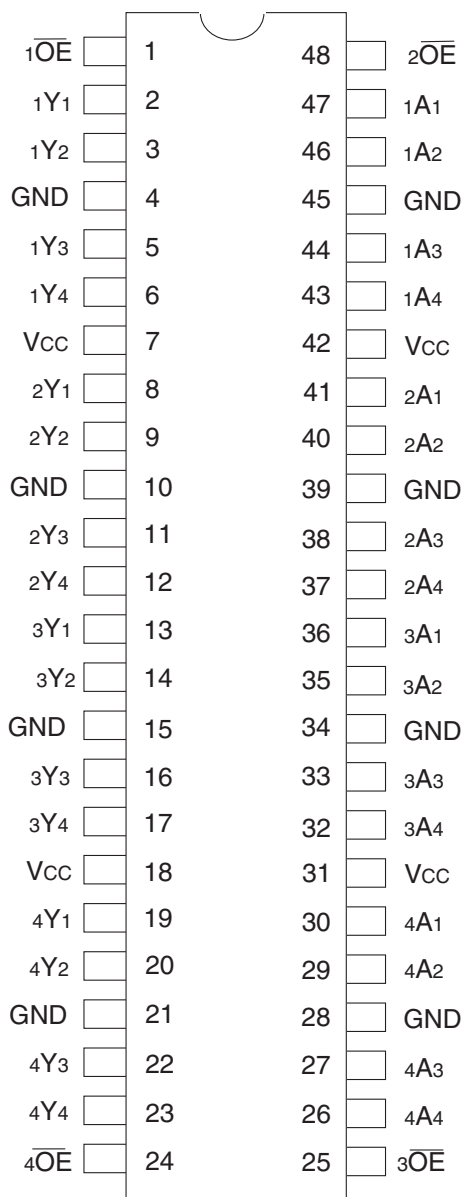

TSSOP  
TOP VIEW

## ABSOLUTE MAXIMUM RATINGS<sup>(1)</sup>

Symbol	Description	Max	Unit
VTERM <sup>(2)</sup>	Terminal Voltage with Respect to GND	-0.5 to +4.6	V
VTERM <sup>(3)</sup>	Terminal Voltage with Respect to GND	-0.5 to VCC+0.5	V
TSTG	Storage Temperature	-65 to +150	°C
IOUT	DC Output Current	-50 to +50	mA
I <sub>IK</sub>	Continuous Clamp Current, V <sub>I</sub> < 0 or V <sub>I</sub> > V <sub>CC</sub>	±50	mA
I <sub>OK</sub>	Continuous Clamp Current, V <sub>O</sub> < 0	-50	mA
I <sub>CC</sub> I <sub>SS</sub>	Continuous Current through each V <sub>CC</sub> or GND	±100	mA

### NOTES:

- Stresses greater than those listed under ABSOLUTE MAXIMUM RATINGS may cause permanent damage to the device. This is a stress rating only and functional operation of the device at these or any other conditions above those indicated in the operational sections of this specification is not implied. Exposure to absolute maximum rating conditions for extended periods may affect reliability.
- V<sub>CC</sub> terminals.
- All terminals except V<sub>CC</sub>.

## CAPACITANCE (T<sub>A</sub> = +25°C, F = 1.0MHz)

Symbol	Parameter <sup>(1)</sup>	Conditions	Typ.	Max.	Unit
C <sub>IN</sub>	Input Capacitance	V <sub>IN</sub> = 0V	5	7	pF
C <sub>OUT</sub>	Output Capacitance	V <sub>OUT</sub> = 0V	7	9	pF
C <sub>I/O</sub>	I/O Port Capacitance	V <sub>IN</sub> = 0V	7	9	pF

### NOTE:

- As applicable to the device type.

## PIN DESCRIPTION

Pin Names	Description
x $\overline{OE}$	3-State Output Enable Inputs (Active LOW)
xAx	Data Inputs <sup>(1)</sup>
xYx	3-State Outputs

### NOTE:

- These pins have "Bus-Hold". All other pins are standard inputs, outputs, or I/Os.

## FUNCTION TABLE (EACH 4-BIT BUFFER)<sup>(1)</sup>

Inputs		Outputs
x $\overline{OE}$	xAx	xYx
L	H	H
L	L	L
H	X	Z

### NOTE:

- H = HIGH Voltage Level  
X = Don't Care  
L = LOW Voltage Level  
Z = High-Impedance

## DC ELECTRICAL CHARACTERISTICS OVER OPERATING RANGE

Following Conditions Apply Unless Otherwise Specified:

Operating Condition:  $T_A = -40^{\circ}\text{C}$  to  $+85^{\circ}\text{C}$

Symbol	Parameter	Test Conditions		Min.	Typ. <sup>(1)</sup>	Max.	Unit
V <sub>IH</sub>	Input HIGH Voltage Level	V <sub>CC</sub> = 2.3V to 2.7V		1.7	—	—	V
		V <sub>CC</sub> = 2.7V to 3.6V		2	—	—	
V <sub>IL</sub>	Input LOW Voltage Level	V <sub>CC</sub> = 2.3V to 2.7V		—	—	0.7	V
		V <sub>CC</sub> = 2.7V to 3.6V		—	—	0.8	
I <sub>IH</sub>	Input HIGH Current	V <sub>CC</sub> = 3.6V	V <sub>I</sub> = V <sub>CC</sub>	—	—	±5	μA
I <sub>IL</sub>	Input LOW Current	V <sub>CC</sub> = 3.6V	V <sub>I</sub> = GND	—	—	±5	μA
I <sub>OZH</sub> I <sub>OZL</sub>	High Impedance Output Current (3-State Output pins)	V <sub>CC</sub> = 3.6V	V <sub>O</sub> = V <sub>CC</sub>	—	—	±10	μA
			V <sub>O</sub> = GND	—	—	±10	
V <sub>IK</sub>	Clamp Diode Voltage	V <sub>CC</sub> = 2.3V, I <sub>IN</sub> = -18mA		—	-0.7	-1.2	V
V <sub>H</sub>	Input Hysteresis	V <sub>CC</sub> = 3.3V		—	100	—	mV
I <sub>CC1</sub> I <sub>CC2</sub> I <sub>CC3</sub>	Quiescent Power Supply Current	V <sub>CC</sub> = 3.6V V <sub>IN</sub> = GND or V <sub>CC</sub>		—	0.1	40	μA
ΔI <sub>CC</sub>	Quiescent Power Supply Current Variation	One input at V <sub>CC</sub> - 0.6V, other inputs at V <sub>CC</sub> or GND		—	—	750	μA

**NOTE:**

1. Typical values are at V<sub>CC</sub> = 3.3V, +25°C ambient.

## BUS-HOLD CHARACTERISTICS

Symbol	Parameter <sup>(1)</sup>	Test Conditions		Min.	Typ. <sup>(2)</sup>	Max.	Unit
I <sub>BHH</sub> I <sub>BHL</sub>	Bus-Hold Input Sustain Current	V <sub>CC</sub> = 3V	V <sub>I</sub> = 2V	-75	—	—	μA
			V <sub>I</sub> = 0.8V	75	—	—	
I <sub>BHH</sub> I <sub>BHL</sub>	Bus-Hold Input Sustain Current	V <sub>CC</sub> = 2.3V	V <sub>I</sub> = 1.7V	-45	—	—	μA
			V <sub>I</sub> = 0.7V	45	—	—	
I <sub>BHHO</sub> I <sub>BHLO</sub>	Bus-Hold Input Overdrive Current	V <sub>CC</sub> = 3.6V	V <sub>I</sub> = 0 to 3.6V	—	—	±500	μA

**NOTES:**

1. Pins with Bus-Hold are identified in the pin description.
2. Typical values are at V<sub>CC</sub> = 3.3V, +25°C ambient.

## OUTPUT DRIVE CHARACTERISTICS

Symbol	Parameter	Test Conditions <sup>(1)</sup>		Min.	Max.	Unit
VOH	Output HIGH Voltage	V <sub>CC</sub> = 2.3V to 3.6V	I <sub>OH</sub> = -0.1mA	V <sub>CC</sub> -0.2	—	V
		V <sub>CC</sub> = 2.3V	I <sub>OH</sub> = -6mA	2	—	
		V <sub>CC</sub> = 2.3V	I <sub>OH</sub> = -12mA	1.7	—	
		V <sub>CC</sub> = 2.7V		2.2	—	
		V <sub>CC</sub> = 3V		2.4	—	
		V <sub>CC</sub> = 3V	I <sub>OH</sub> = -24mA	2	—	
VOL	Output LOW Voltage	V <sub>CC</sub> = 2.3V to 3.6V	I <sub>OL</sub> = 0.1mA	—	0.2	V
		V <sub>CC</sub> = 2.3V	I <sub>OL</sub> = 6mA	—	0.4	
			I <sub>OL</sub> = 12mA	—	0.7	
		V <sub>CC</sub> = 2.7V	I <sub>OL</sub> = 12mA	—	0.4	
		V <sub>CC</sub> = 3V	I <sub>OL</sub> = 24mA	—	0.55	

**NOTE:**  
1. V<sub>IH</sub> and V<sub>IL</sub> must be within the min. or max. range shown in the DC ELECTRICAL CHARACTERISTICS OVER OPERATING RANGE table for the appropriate V<sub>CC</sub> range. T<sub>A</sub> = -40°C to +85°C.

## OPERATING CHARACTERISTICS, T<sub>A</sub> = 25°C

Symbol	Parameter	Test Conditions	V <sub>CC</sub> = 2.5V ± 0.2V	V <sub>CC</sub> = 3.3V ± 0.3V	Unit
			Typical	Typical	
CPD	Power Dissipation Capacitance Outputs enabled	C <sub>L</sub> = 0pF, f = 10Mhz	16	19	pF
CPD	Power Dissipation Capacitance Outputs disabled		4	5	

## SWITCHING CHARACTERISTICS<sup>(1)</sup>

Symbol	Parameter	V <sub>CC</sub> = 2.5V ± 0.2V		V <sub>CC</sub> = 2.7V		V <sub>CC</sub> = 3.3V ± 0.3V		Unit
		Min.	Max.	Min.	Max.	Min.	Max.	
t <sub>PLH</sub>	Propagation Delay	1	3.7	—	3.6	1	3	ns
t <sub>PHL</sub>	xAx to xYx							
t <sub>PZH</sub>	Output Enable Time	1	5.7	—	5.4	1	4.4	ns
t <sub>PZL</sub>	x $\overline{OE}$ to xYx							
t <sub>PHZ</sub>	Output Disable Time	1	5.2	—	4.6	1	4.1	ns
t <sub>PLZ</sub>	x $\overline{OE}$ to xYx							
t <sub>SK(o)</sub>	Output Skew <sup>(2)</sup>	—	—	—	—	—	500	ps

**NOTES:**  
1. See TEST CIRCUITS AND WAVEFORMS. T<sub>A</sub> = -40°C to +85°C.  
2. Skew between any two outputs of the same package and switching in the same direction.

## TEST CIRCUITS AND WAVEFORMS

### TEST CONDITIONS

Symbol	V <sub>CC</sub> <sup>(1)</sup> =3.3V±0.3V	V <sub>CC</sub> <sup>(1)</sup> =2.7V	V <sub>CC</sub> <sup>(2)</sup> =2.5V±0.2V	Unit
V <sub>LOAD</sub>	6	6	2 x V <sub>CC</sub>	V
V <sub>IH</sub>	2.7	2.7	V <sub>CC</sub>	V
V <sub>T</sub>	1.5	1.5	V <sub>CC</sub> / 2	V
V <sub>LZ</sub>	300	300	150	mV
V <sub>HZ</sub>	300	300	150	mV
C <sub>L</sub>	50	50	30	pF

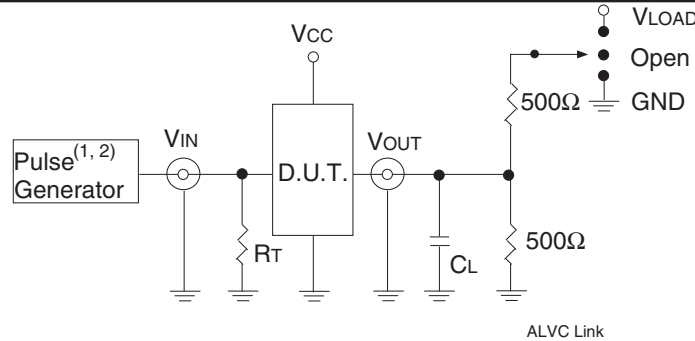

Test Circuit for All Outputs

#### DEFINITIONS:

C<sub>L</sub> = Load capacitance: includes jig and probe capacitance.  
R<sub>T</sub> = Termination resistance: should be equal to Z<sub>OUT</sub> of the Pulse Generator.

#### NOTES:

1. Pulse Generator for All Pulses: Rate ≤ 1.0MHz; t<sub>r</sub> ≤ 2.5ns; t<sub>r</sub> ≤ 2.5ns.
2. Pulse Generator for All Pulses: Rate ≤ 1.0MHz; t<sub>r</sub> ≤ 2ns; t<sub>r</sub> ≤ 2ns.

### SWITCH POSITION

Test	Switch
Open Drain Disable Low Enable Low	V <sub>LOAD</sub>
Disable High Enable High	GND
All Other Tests	Open

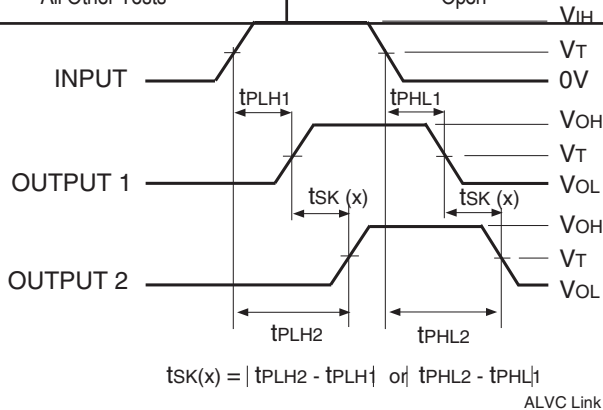

Output Skew - tsk(x)

#### NOTES:

1. For tsk(o) OUTPUT1 and OUTPUT2 are any two outputs.
2. For tsk(b) OUTPUT1 and OUTPUT2 are in the same bank.

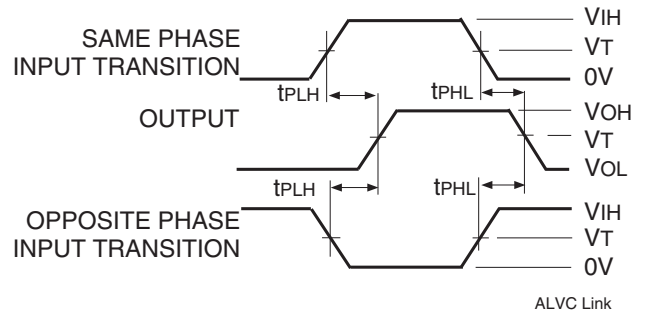

#### Propagation Delay

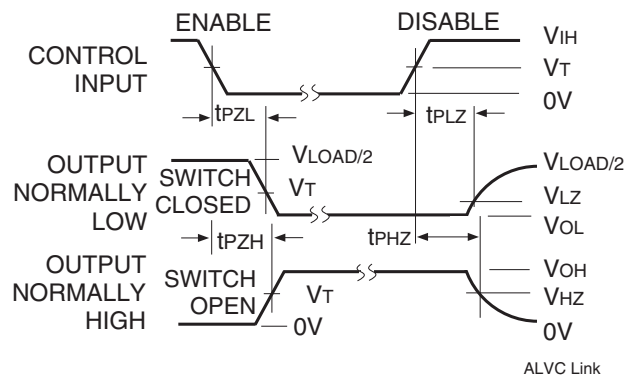

#### Enable and Disable Times

#### NOTE:

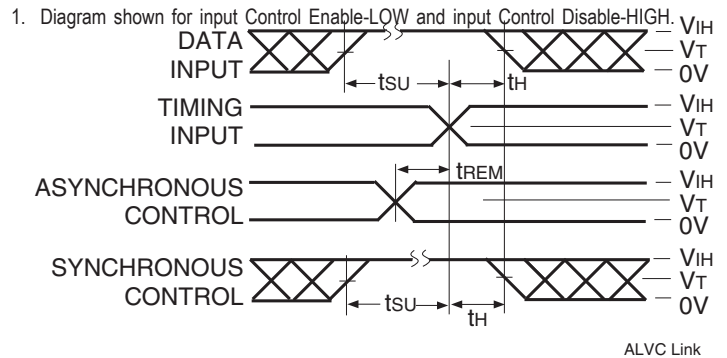

#### Set-up, Hold, and Release Times

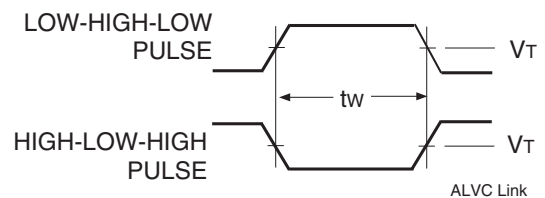

#### Pulse Width

## ORDERING INFORMATION

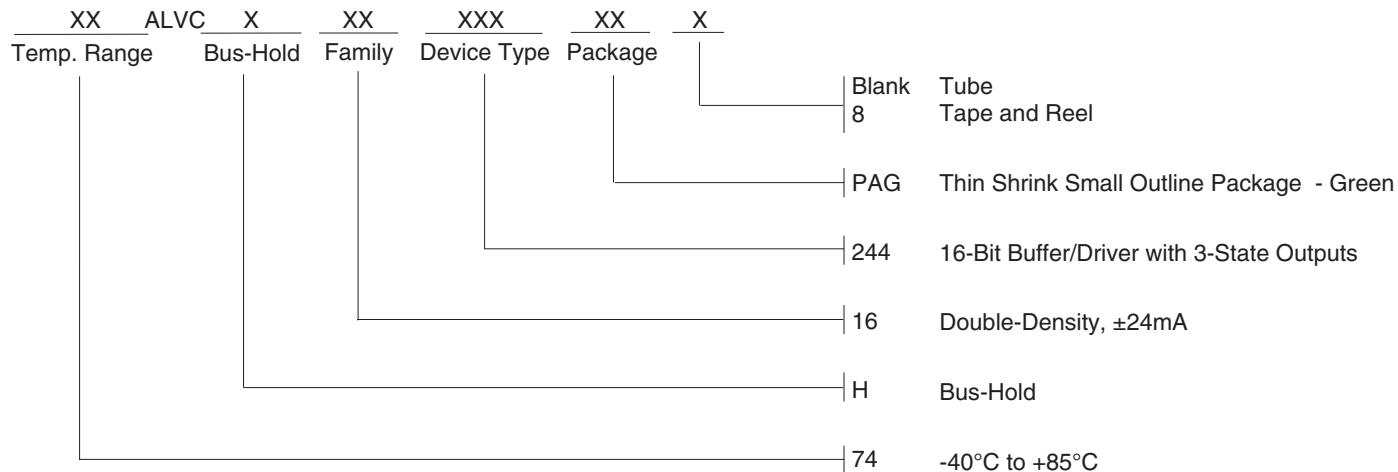

## Datasheet Document History

08/18/2016 Pg. 6 Updated the ordering information by adding Tape and Reel.



**CORPORATE HEADQUARTERS**  
 6024 Silver Creek Valley Road  
 San Jose, CA 95138

**for SALES:**  
 800-345-7015 or 408-284-8200  
 fax: 408-284-2775  
 www.idt.com

**for Tech Support:**  
 logichelp@idt.com