



Chipsmall Limited consists of a professional team with an average of over 10 year of expertise in the distribution of electronic components. Based in Hongkong, we have already established firm and mutual-benefit business relationships with customers from,Europe,America and south Asia,supplying obsolete and hard-to-find components to meet their specific needs.

With the principle of “Quality Parts,Customers Priority,Honest Operation,and Considerate Service”,our business mainly focus on the distribution of electronic components. Line cards we deal with include Microchip,ALPS,ROHM,Xilinx,Pulse,ON,Everlight and Freescale. Main products comprise IC,Modules,Potentiometer,IC Socket,Relay,Connector.Our parts cover such applications as commercial,industrial, and automotives areas.

We are looking forward to setting up business relationship with you and hope to provide you with the best service and solution. Let us make a better world for our industry!



Contact us

Tel: +86-755-8981 8866 Fax: +86-755-8427 6832

Email & Skype: info@chipsmall.com Web: www.chipsmall.com

Address: A1208, Overseas Decoration Building, #122 Zhenhua RD., Futian, Shenzhen, China



Important notice

Dear Customer,

On 7 February 2017 the former NXP Standard Product business became a new company with the tradename **Nexperia**. Nexperia is an industry leading supplier of Discrete, Logic and PowerMOS semiconductors with its focus on the automotive, industrial, computing, consumer and wearable application markets

In data sheets and application notes which still contain NXP or Philips Semiconductors references, use the references to Nexperia, as shown below.

Instead of <http://www.nxp.com>, <http://www.philips.com/> or <http://www.semiconductors.philips.com/>, use <http://www.nexperia.com>

Instead of sales.addresses@www.nxp.com or sales.addresses@www.semiconductors.philips.com, use salesaddresses@nexperia.com (email)

Replace the copyright notice at the bottom of each page or elsewhere in the document, depending on the version, as shown below:

- © NXP N.V. (year). All rights reserved or © Koninklijke Philips Electronics N.V. (year). All rights reserved

Should be replaced with:

- © **Nexperia B.V. (year). All rights reserved.**

If you have any questions related to the data sheet, please contact our nearest sales office via e-mail or telephone (details via salesaddresses@nexperia.com). Thank you for your cooperation and understanding,

Kind regards,

Team Nexperia

DATA SHEET

74ALVCH16843

18-bit bus-interface D-type latch (3-State)

Product specification

1998 Aug 04

IC24 Data Handbook

18-bit bus interface D-type latch (3-State)

74ALVCH16843

FEATURES

- Wide supply voltage range of 1.2V to 3.6V
- Complies with JEDEC standard no. 8-1A.
- CMOS low power consumption
- Direct interface with TTL levels
- Current drive ± 24 mA at 3.0 V
- MULTIBYTE™ flow-through standard pin-out architecture
- Low inductance multiple V_{CC} and GND pins for minimum noise and ground bounce
- All data inputs have bus hold
- Output drive capability 50Ω transmission lines @ 85°C

DESCRIPTION

The 74ALVCH16843 has two 9-bit D-type latch featuring separate D-type inputs for each latch and 3-State outputs for bus oriented applications. The two sections of each register are controlled independently by the latch enable (\overline{nLE}), clear (\overline{nCLR}), preset (\overline{nPRE}) and output enable (\overline{nOE}) control gates.

When \overline{nOE} is LOW, the data in the registers appear at the outputs. When \overline{nOE} is HIGH, the outputs are in the high impedance OFF state. Operation of the \overline{nOE} input does not affect the state of the flip-flops.

The 74ALVCH16843 has active bus hold circuitry which is provided to hold unused or floating data inputs at a valid logic level. This feature eliminates the need for external pull-up or pull-down resistors.

PIN CONFIGURATION

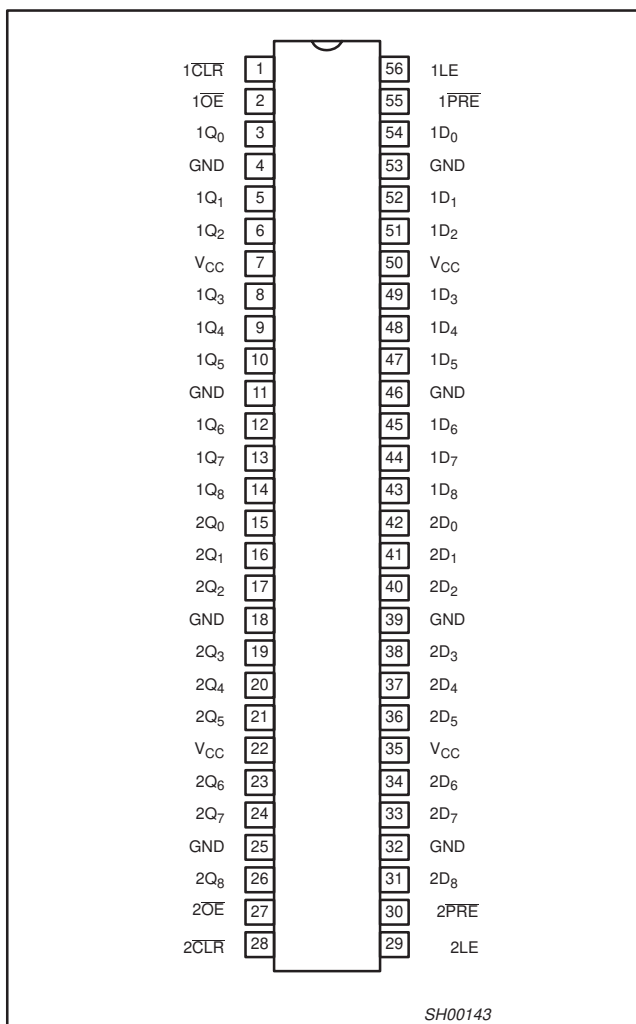

SH00143

QUICK REFERENCE DATA

GND = 0V; $T_{amb} = 25^\circ\text{C}$; $t_r = t_f \leq 2.5\text{ns}$

SYMBOL	PARAMETER	CONDITIONS	TYPICAL	UNIT	
t_{PHL}/t_{PLH}	Propagation delay nDn to nQn	$V_{CC} = 2.5\text{V}, C_L = 30\text{pF}$ $V_{CC} = 3.3\text{V}, C_L = 50\text{pF}$	2.2 2.1	ns	
	Propagation delay nLE to nQn	$V_{CC} = 2.5\text{V}, C_L = 30\text{pF}$ $V_{CC} = 3.3\text{V}, C_L = 50\text{pF}$	2.3 2.0	ns	
C_I	Input capacitance		5.0	pF	
C_{PD}	Power dissipation capacitance per buffer	$V_I = \text{GND to } V_{CC}^1$	transparent mode Output enabled Output disabled	17 3	pF
			Clocked mode Output enabled Output disabled	19 9	

NOTES:

1. C_{PD} is used to determine the dynamic power dissipation (P_D in μW):
 $P_D = C_{PD} \times V_{CC}^2 \times f_i + \sum (C_L \times V_{CC}^2 \times f_o)$ where: f_i = input frequency in MHz; C_L = output load capacitance in pF;
 f_o = output frequency in MHz; V_{CC} = supply voltage in V; $\sum (C_L \times V_{CC}^2 \times f_o)$ = sum of outputs.

ORDERING INFORMATION

PACKAGES	TEMPERATURE RANGE	OUTSIDE NORTH AMERICA	NORTH AMERICA	DRAWING NUMBER
56-Pin Plastic Thin Shrink Small Outline (TSSOP) Type II	-40°C to +85°C	74ALVCH16843 DGG	ACH16843 DGG	SOT364-1

18-bit bus interface D-type latch (3-State)

74ALVCH16843

PIN DESCRIPTION

PIN NUMBER	SYMBOL	NAME AND FUNCTION
1	1 $\overline{\text{CLR}}$	Clear input (active LOW)
2	1 $\overline{\text{OE}}$	Output enable input (active LOW)
55	1PRE	Preset input (active LOW)
56	1LE	Latch enable input (active HIGH)
54, 52, 51, 49, 48, 47, 45, 44, 43	1D0 to 1D8	Data inputs
3, 5, 6, 8, 9, 10, 12, 13, 14	1Q0 to 1Q8	Data outputs
4, 11, 18, 25, 32, 39, 46, 53	GND	Ground (0V)
7, 22, 35, 50	V _{CC}	Positive supply voltage
27	2 $\overline{\text{OE}}$	Output enable input (active LOW)
28	2 $\overline{\text{CLR}}$	Clear input (active LOW)
29	2LE	Latch enable input (active HIGH)
30	2PRE	Preset input (active LOW)
42, 41, 40, 38, 37, 36, 34, 33, 31	2D0 to 2D8	Data inputs
15, 16, 17, 19, 20, 21, 23, 24, 26	2Q0 to 2Q8	Data outputs

FUNCTION TABLE

INPUTS					OUTPUT
nPRE	n $\overline{\text{CLR}}$	n $\overline{\text{OE}}$	LE	D _x	Q
L	X	L	X	X	H
H	L	L	X	X	L
H	H	L	H	L	L
H	H	L	H	H	H
H	H	L	H	X	Q ₀
X	X	H	H	X	Z

- H = HIGH voltage level
- L = LOW voltage level
- X = Don't care
- Z = High impedance "off" state

LOGIC SYMBOL

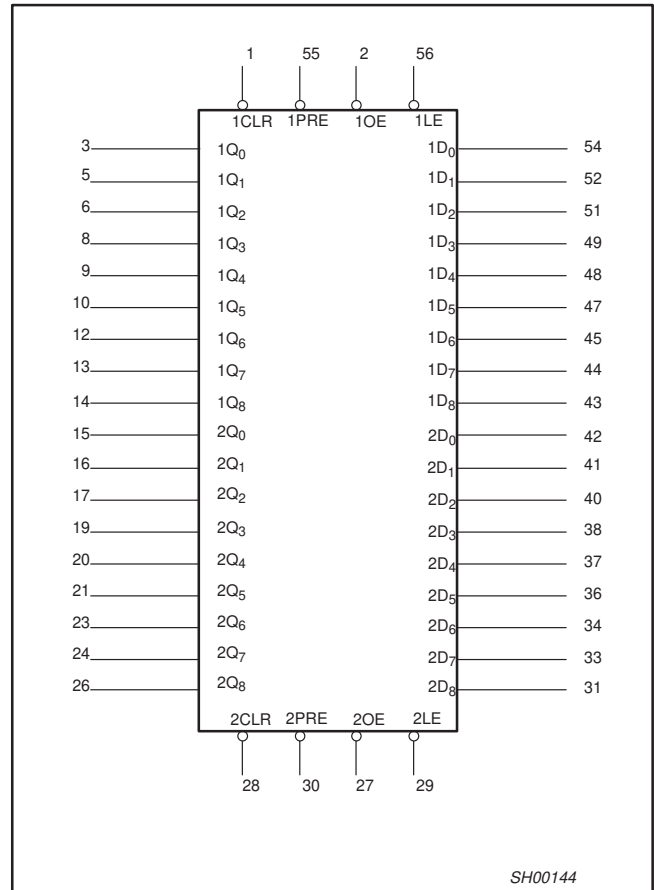

18-bit bus interface D-type latch (3-State)

74ALVCH16843

LOGIC DIAGRAM

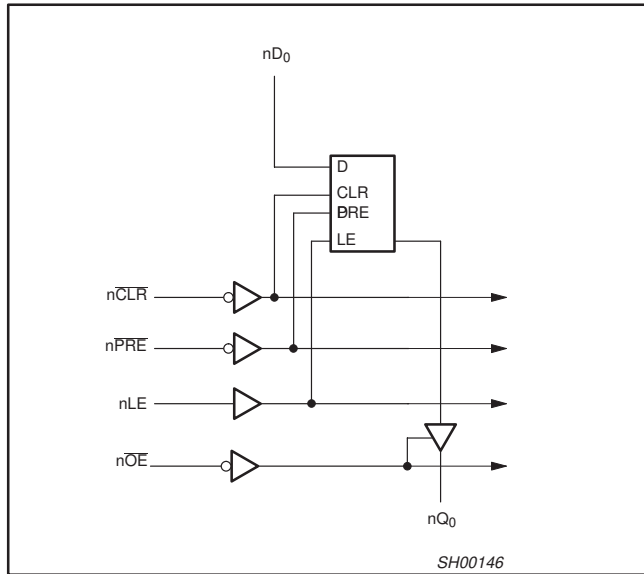

LOGIC SYMBOL (IEEE/IEC)

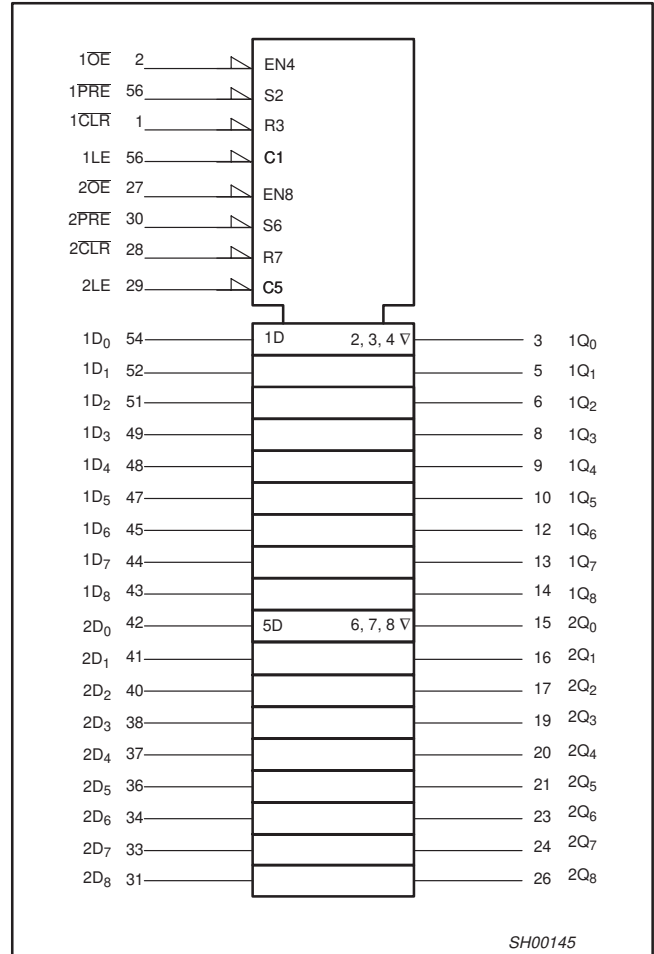

BUS HOLD CIRCUIT

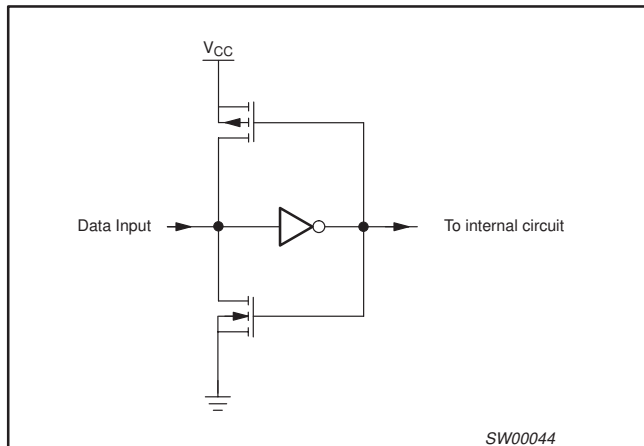

18-bit bus interface D-type latch (3-State)

74ALVCH16843

RECOMMENDED OPERATING CONDITIONS

SYMBOL	PARAMETER	CONDITIONS	MIN	MAX	UNIT
V_{CC}	DC supply voltage 2.5V range (for max. speed performance @ 30 pF output load)		2.3	2.7	V
	DC supply voltage 3.3V range (for max. speed performance @ 50 pF output load)		3.0	3.6	
V_I	DC Input voltage range		0	V_{CC}	V
V_O	DC output voltage range		0	V_{CC}	V
T_{amb}	Operating free-air temperature range		-40	+85	°C
t_r, t_f	Input rise and fall times	$V_{CC} = 2.3$ to $3.0V$ $V_{CC} = 3.0$ to $3.6V$	0 0	20 10	ns/V

ABSOLUTE MAXIMUM RATINGS

In accordance with the Absolute Maximum Rating System (IEC 134)
 Voltages are referenced to GND (ground = 0V)

SYMBOL	PARAMETER	CONDITIONS	RATING	UNIT
V_{CC}	DC supply voltage		-0.5 to +4.6	V
I_{IK}	DC input diode current	$V_I < 0$	-50	mA
V_I	DC input voltage	For control pins ²	-0.5 to +4.6	V
		For data inputs ²	-0.5 to $V_{CC} + 0.5$	
I_{OK}	DC output diode current	$V_O > V_{CC}$ or $V_O < 0$	±50	mA
V_O	DC output voltage	Note 2	-0.5 to $V_{CC} + 0.5$	V
I_O	DC output source or sink current	$V_O = 0$ to V_{CC}	±50	mA
I_{GND}, I_{CC}	DC V_{CC} or GND current		±100	mA
T_{stg}	Storage temperature range		-65 to +150	°C
P_{TOT}	Power dissipation per package –plastic medium-shrink (SSOP) –plastic thin-medium-shrink (TSSOP)	For temperature range: -40 to +125 °C above +55°C derate linearly with 11.3 mW/K above +55°C derate linearly with 8 mW/K	850	mW
			600	

NOTE:

- Stresses beyond those listed may cause permanent damage to the device. These are stress ratings only and functional operation of the device at these or any other conditions beyond those indicated under “recommended operating conditions” is not implied. Exposure to absolute-maximum-rated conditions for extended periods may affect device reliability.
- The input and output voltage ratings may be exceeded if the input and output current ratings are observed.

18-bit bus interface D-type latch (3-State)

74ALVCH16843

DC ELECTRICAL CHARACTERISTICS

Over recommended operating conditions. Voltage are referenced to GND (ground = 0 V).

SYMBOL	PARAMETER	TEST CONDITIONS	LIMITS			UNIT
			Temp = -40°C to +85°C			
			MIN	TYP ¹	MAX	
V _{IH}	HIGH level Input voltage	V _{CC} = 2.3 to 2.7V	1.7	1.2		V
		V _{CC} = 2.7 to 3.6V	2.0	1.5		
V _{IL}	LOW level Input voltage	V _{CC} = 2.3 to 2.7V		1.2	0.7	V
		V _{CC} = 2.7 to 3.6V		1.5	0.8	
V _{OH}	HIGH level output voltage	V _{CC} = 2.3 to 3.6V; V _I = V _{IH} or V _{IL} ; I _O = -100μA	V _{CC} - 0.2	V _{CC}		V
		V _{CC} = 2.3V; V _I = V _{IH} or V _{IL} ; I _O = -6mA	V _{CC} - 0.3	V _{CC} - 0.08		
		V _{CC} = 2.3V; V _I = V _{IH} or V _{IL} ; I _O = -12mA	V _{CC} - 0.6	V _{CC} - 0.26		
		V _{CC} = 2.7V; V _I = V _{IH} or V _{IL} ; I _O = -12mA	V _{CC} - 0.5	V _{CC} - 0.14		
		V _{CC} = 3.0V; V _I = V _{IH} or V _{IL} ; I _O = -12mA	V _{CC} - 0.6	V _{CC} - 0.09		
		V _{CC} = 3.0V; V _I = V _{IH} or V _{IL} ; I _O = -24mA	V _{CC} - 1.0	V _{CC} - 0.28		
V _{OL}	LOW level output voltage	V _{CC} = 2.3 to 3.6V; V _I = V _{IH} or V _{IL} ; I _O = 100μA		GND	0.20	V
		V _{CC} = 2.3V; V _I = V _{IH} or V _{IL} ; I _O = 6mA		0.07	0.40	V
		V _{CC} = 2.3V; V _I = V _{IH} or V _{IL} ; I _O = 12mA		0.15	0.70	V
		V _{CC} = 2.7V; V _I = V _{IH} or V _{IL} ; I _O = 12mA		0.14	0.40	
		V _{CC} = 3.0V; V _I = V _{IH} or V _{IL} ; I _O = 24mA		0.27	0.55	
I _I	Input leakage current	V _{CC} = 2.3 to 3.6V; V _I = V _{CC} or GND		0.1	5	μA
I _{OZ}	3-State output OFF-state current	V _{CC} = 2.3 to 3.6V; V _I = V _{IH} or V _{IL} ; V _O = V _{CC} or GND		0.1	10	μA
I _{CC}	Quiescent supply current	V _{CC} = 2.3 to 3.6V; V _I = V _{CC} or GND; I _O = 0		0.2	40	μA
ΔI _{CC}	Additional quiescent supply current	V _{CC} = 2.3V to 3.6V; V _I = V _{CC} - 0.6V; I _O = 0		150	750	μA
I _{BHL} ²	Bus hold LOW sustaining current	V _{CC} = 2.3V; V _I = 0.7V	45	-		μA
		V _{CC} = 3.0V; V _I = 0.8V	75	150		
I _{BHH} ²	Bus hold HIGH sustaining current	V _{CC} = 2.3V; V _I = 1.7V	-45			μA
		V _{CC} = 3.0V; V _I = 2.0V	-75	-175		
I _{BHLO} ²	Bus hold LOW overdrive current	V _{CC} = 3.6V	500			μA
I _{BHHO} ²	Bus hold HIGH overdrive current	V _{CC} = 3.6V	-500			μA

NOTES:

1. All typical values are at T_{amb} = 25°C.
2. Valid for data inputs of bus hold parts.

18-bit bus interface D-type latch (3-State)

74ALVCH16843

AC CHARACTERISTICS FOR $V_{CC} = 2.3V$ TO $2.7V$ RANGEGND = 0V; $t_r = t_f \leq 2.0ns$; $C_L = 30pF$

SYMBOL	PARAMETER	WAVEFORM	LIMITS			UNIT
			$V_{CC} = 2.3$ to $2.7V$			
			MIN	TYP ¹	MAX	
t_{PHL}/t_{PLH}	Propagation delay nDn to nQn	1, 6	1.0	2.2	4.3	ns
	Propagation delay nLE to nQn	2, 6	1.0	2.3	4.6	
	Propagation delay nPRE to nQn	1, 6	1.0	2.5	4.8	
	Propagation delay nCLR to nQn	1, 6	1.0	2.5	4.8	
t_{PZH}/t_{PZL}	3-State output enable time nOE to nQn	5, 6	1.0	2.8	5.8	ns
t_{PHZ}/t_{PLZ}	3-State output disable time nOE to nQn	5, 6	1.1	2.2	4.3	ns
t_{SU}	Set-up time nDn to nLE	3, 6	0.5	-0.1	-	ns
t_h	Hold time nDn to nLE	3, 6	0.9	0.5	-	ns
t_w	nLE pulse width HIGH	2, 6	1.5	0.5	-	ns
	nPRE pulse width LOW	4, 6	1.5	0.5	-	
	nCLR pulse width LOW	4, 6	1.5	0.5	-	
t_{REM}	Recovery time nPRE to nLE	4, 6	0.5	1.1	-	ns
	Recovery time nCLR to nLE	4, 6	0.5	1.0	-	

NOTE:1. All typical values are at $V_{CC} = 3.3V$ and $T_{amb} = 25^\circ C$.**AC CHARACTERISTICS FOR $V_{CC} = 3.0V$ TO $3.6V$ RANGE AND $V_{CC} = 2.7V$** GND = 0V; $t_r = t_f \leq 2.5ns$; $C_L = 50pF$

SYMBOL	PARAMETER	WAVEFORM	LIMITS			LIMITS			UNIT
			$V_{CC} = 3.3 \pm 0.3V$			$V_{CC} = 2.7V$			
			MIN	TYP ^{1, 2}	MAX	MIN	TYP ¹	MAX	
t_{PHL}/t_{PLH}	Propagation delay nDn to nQn	1, 6	1.0	2.1	3.5	1.0	2.3	4.0	ns
	Propagation delay nLE to nQn	2, 6	1.0	2.0	3.5	1.0	2.1	3.9	
	Propagation delay nPRE to nQn	1, 6	1.0	2.2	3.8	1.0	2.6	4.5	
	Propagation delay nCLR to nQn	1, 6	1.0	2.3	3.9	1.0	2.5	4.3	
t_{PZH}/t_{PZL}	3-State output enable time nOE to nQn	5, 6	1.0	2.5	4.4	1.0	3.0	5.3	ns
t_{PHZ}/t_{PLZ}	3-State output disable time nOE to nQn	5, 6	1.3	2.6	4.0	1.3	2.8	4.4	ns
t_{SU}	Set-up time nDn to nLE	3, 6	0.5	0.0	-	0.5	-0.3	-	ns
t_h	Hold time nDn to nLE	3, 6	0.9	0.5	-	0.9	0.5	-	ns
t_w	nLE pulse width HIGH	2, 6	1.5	0.5	-	1.5	0.5	-	ns
	nPRE pulse width LOW	4, 6	1.5	0.5	-	1.5	0.6	-	
	nCLR pulse width LOW	4, 6	1.5	0.5	-	1.5	0.5	-	
t_{REM}	Recovery time nPRE to nLE	4, 6	1.0	0.4	-	0.8	-0.2	-	ns
	Recovery time nCLR to nLE	4, 6	0.8	0.2	-	0.6	-0.4	-	

NOTES:

- All typical values are measured $T_{amb} = 25^\circ C$.
- Typical value is measured at $V_{CC} = 3.3V$

18-bit bus interface D-type latch (3-State)

74ALVCH16843

AC WAVEFORMS FOR $V_{CC} = 2.3V$ TO $2.7V$ AND $V_{CC} < 2.3V$ RANGE

$V_M = 0.5 V$
 $V_X = V_{OL} + 0.15V$
 $V_Y = V_{OH} - 0.15V$
 V_{OL} and V_{OH} are the typical output voltage drop that occur with the output load.
 $V_I = V_{CC}$

AC WAVEFORMS FOR $V_{CC} = 3.0V$ TO $3.6V$ AND $V_{CC} = 2.7V$ RANGE

$V_M = 1.5 V$
 $V_X = V_{OL} + 0.3V$
 $V_Y = V_{OH} - 0.3V$
 V_{OL} and V_{OH} are the typical output voltage drop that occur with the output load.
 $V_I = 2.7V$

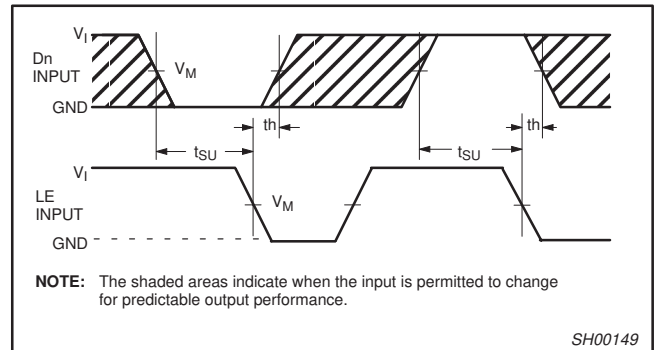

Waveform 3. Data set-up and hold times for the Dn input to the LE input

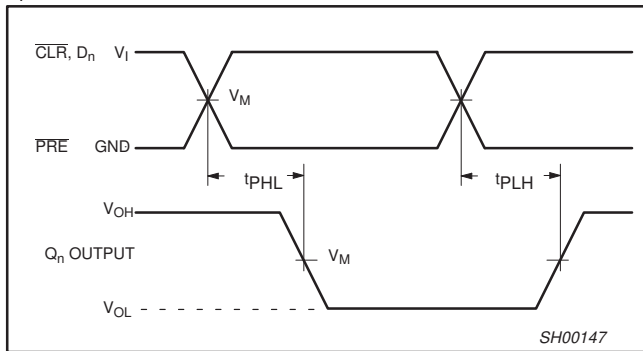

Waveform 1. Data input (Dn) to output (Qn), clear input (CLR) to output (Qn) and preset input (PRE) to output (Qn) propagation delay

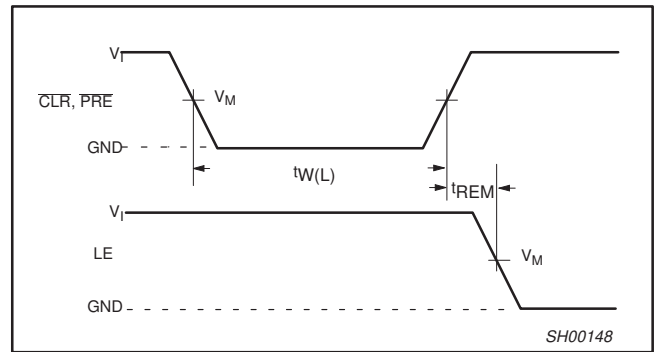

Waveform 4. Clear (CLR) and preset (PRE) pulse width, the clear (CLR) and preset (PRE) to latch (LE) removal time

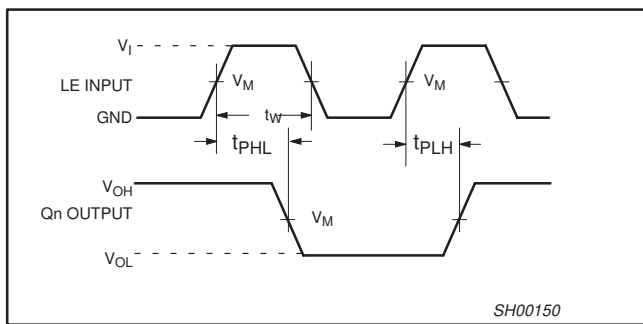

Waveform 2. Latch enable input (LE) pulse width, the latch enable input to output (Qn) propagation delay

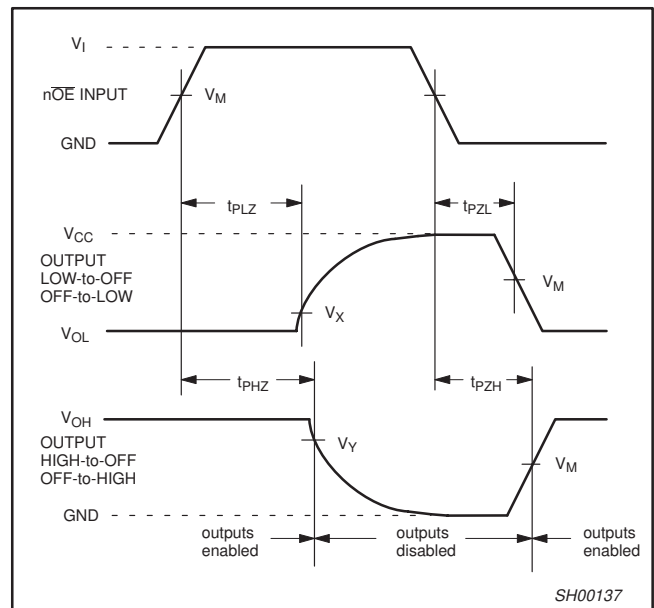

Waveform 5. 3-State enable and disable times

18-bit bus interface D-type latch (3-State)

74ALVCH16843

TEST CIRCUIT

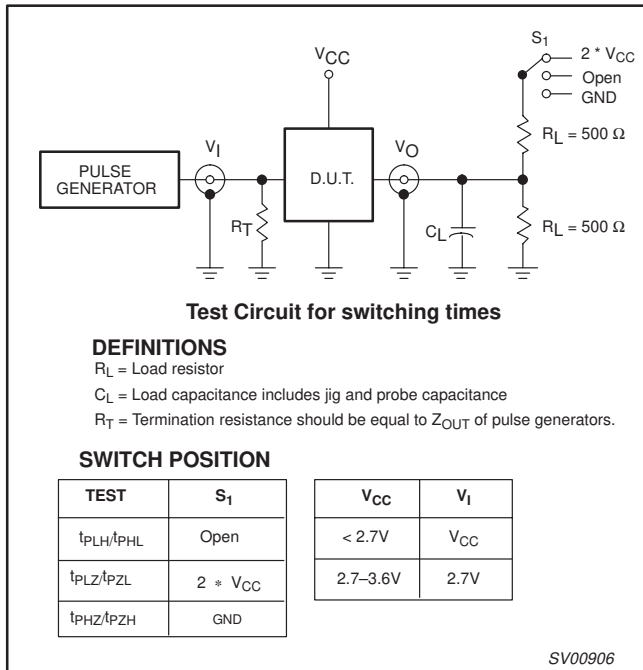

Waveform 6. Load circuitry for switching times

18-bit bus interface D-type latch (3-State)

74ALVCH16843

TSSOP56: plastic thin shrink small outline package; 56 leads; body width 6.1 mm

SOT364-1

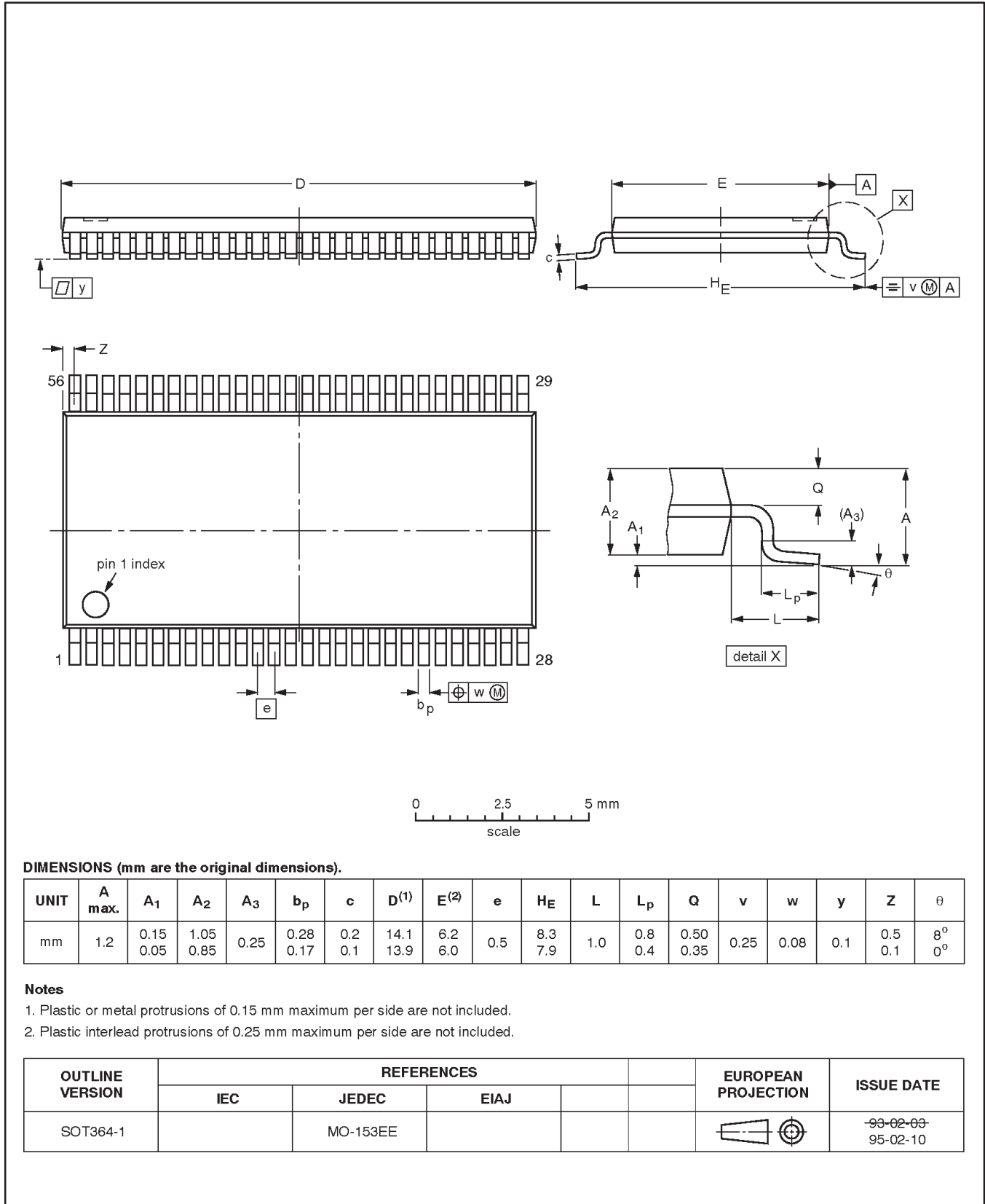

18-bit bus interface D-type latch (3-State)

74ALVCH16843

NOTES

18-bit bus interface D-type latch (3-State)

74ALVCH16843

Data sheet status

Data sheet status	Product status	Definition [1]
Objective specification	Development	This data sheet contains the design target or goal specifications for product development. Specification may change in any manner without notice.
Preliminary specification	Qualification	This data sheet contains preliminary data, and supplementary data will be published at a later date. Philips Semiconductors reserves the right to make changes at any time without notice in order to improve design and supply the best possible product.
Product specification	Production	This data sheet contains final specifications. Philips Semiconductors reserves the right to make changes at any time without notice in order to improve design and supply the best possible product.

[1] Please consult the most recently issued datasheet before initiating or completing a design.

Definitions

Short-form specification — The data in a short-form specification is extracted from a full data sheet with the same type number and title. For detailed information see the relevant data sheet or data handbook.

Limiting values definition — Limiting values given are in accordance with the Absolute Maximum Rating System (IEC 134). Stress above one or more of the limiting values may cause permanent damage to the device. These are stress ratings only and operation of the device at these or at any other conditions above those given in the Characteristics sections of the specification is not implied. Exposure to limiting values for extended periods may affect device reliability.

Application information — Applications that are described herein for any of these products are for illustrative purposes only. Philips Semiconductors make no representation or warranty that such applications will be suitable for the specified use without further testing or modification.

Disclaimers

Life support — These products are not designed for use in life support appliances, devices or systems where malfunction of these products can reasonably be expected to result in personal injury. Philips Semiconductors customers using or selling these products for use in such applications do so at their own risk and agree to fully indemnify Philips Semiconductors for any damages resulting from such application.

Right to make changes — Philips Semiconductors reserves the right to make changes, without notice, in the products, including circuits, standard cells, and/or software, described or contained herein in order to improve design and/or performance. Philips Semiconductors assumes no responsibility or liability for the use of any of these products, conveys no license or title under any patent, copyright, or mask work right to these products, and makes no representations or warranties that these products are free from patent, copyright, or mask work right infringement, unless otherwise specified.

Philips Semiconductors
811 East Arques Avenue
P.O. Box 3409
Sunnyvale, California 94088-3409
Telephone 800-234-7381

© Copyright Philips Electronics North America Corporation 1998
All rights reserved. Printed in U.S.A.

print code

Date of release: 07-98

Document order number:

9397-750-04562

Let's make things better.