



Chipsmall Limited consists of a professional team with an average of over 10 year of expertise in the distribution of electronic components. Based in Hongkong, we have already established firm and mutual-benefit business relationships with customers from,Europe,America and south Asia,supplying obsolete and hard-to-find components to meet their specific needs.

With the principle of “Quality Parts,Customers Priority,Honest Operation,and Considerate Service”,our business mainly focus on the distribution of electronic components. Line cards we deal with include Microchip,ALPS,ROHM,Xilinx,Pulse,ON,Everlight and Freescale. Main products comprise IC,Modules,Potentiometer,IC Socket,Relay,Connector.Our parts cover such applications as commercial,industrial, and automotives areas.

We are looking forward to setting up business relationship with you and hope to provide you with the best service and solution. Let us make a better world for our industry!



Contact us

Tel: +86-755-8981 8866 Fax: +86-755-8427 6832

Email & Skype: info@chipsmall.com Web: www.chipsmall.com

Address: A1208, Overseas Decoration Building, #122 Zhenhua RD., Futian, Shenzhen, China



Important notice

Dear Customer,

On 7 February 2017 the former NXP Standard Product business became a new company with the tradename **Nexperia**. Nexperia is an industry leading supplier of Discrete, Logic and PowerMOS semiconductors with its focus on the automotive, industrial, computing, consumer and wearable application markets

In data sheets and application notes which still contain NXP or Philips Semiconductors references, use the references to Nexperia, as shown below.

Instead of <http://www.nxp.com>, <http://www.philips.com/> or <http://www.semiconductors.philips.com/>, use <http://www.nexperia.com>

Instead of sales.addresses@www.nxp.com or sales.addresses@www.semiconductors.philips.com, use salesaddresses@nexperia.com (email)

Replace the copyright notice at the bottom of each page or elsewhere in the document, depending on the version, as shown below:

- © NXP N.V. (year). All rights reserved or © Koninklijke Philips Electronics N.V. (year). All rights reserved

Should be replaced with:

- © **Nexperia B.V. (year). All rights reserved.**

If you have any questions related to the data sheet, please contact our nearest sales office via e-mail or telephone (details via salesaddresses@nexperia.com). Thank you for your cooperation and understanding,

Kind regards,

Team Nexperia

74ALVT162823

18-bit bus-interface D-type flip-flop with reset and enable with 30 Ω termination resistors; 3-state

Rev. 02 — 11 August 2005

Product data sheet

1. General description

The 74ALVT162823 18-bit bus interface register is designed to eliminate the extra packages required to buffer existing registers and provide extra data width for wider data or address paths of buses carrying parity.

The 74ALVT162823 has two 9-bit wide buffered registers with clock enable (\overline{nCE}) and master reset (\overline{nMR}) which are ideal for parity bus interfacing in high microprogrammed systems.

The registers are fully edge-triggered. The state of each D input, one set-up time before the LOW-to-HIGH clock transition is transferred to the corresponding Q output of the flip-flop.

The 74ALVT162823 is designed with 30 Ω series resistance in both the pull-up and pull-down output structures. This design reduces line noise in applications such as memory address drivers, clock drivers, and bus receivers or transmitters.

2. Features

- Two sets of high speed parallel registers with positive edge-triggered D-type flip-flops
- 5 V I/O compatible
- Ideal where high speed, light loading or increased fan-in are required with MOS microprocessors
- Bus hold data inputs eliminate the need for external pull-up resistors to hold unused inputs
- Live insertion and extraction permitted
- Power-up 3-state
- Power-up reset
- Output capability: +12 mA to -12 mA
- Outputs include series resistance of 30 Ω making external termination resistors unnecessary
- Latch-up protection:
 - ◆ JESD78: exceeds 500 mA
- ESD protection:
 - ◆ MIL STD 883, method 3015: exceeds 2000 V
 - ◆ Machine Model: exceeds 200 V

PHILIPS

3. Quick reference data

Table 1: Quick reference data

$T_{amb} = 25^{\circ}\text{C}$.

Symbol	Parameter	Conditions	Min	Typ	Max	Unit
t _{PLH}	propagation delay nCP to nQx	C _L = 50 pF; V _{CC} = 2.5 V	-	3.7	-	ns
		C _L = 50 pF; V _{CC} = 3.3 V	-	2.9	-	ns
t _{PHL}	propagation delay nCP to nQx	C _L = 50 pF; V _{CC} = 2.5 V	-	2.8	-	ns
		C _L = 50 pF; V _{CC} = 3.3 V	-	2.3	-	ns
C _i	input capacitance	V _I = 0 V or V _{CC}	-	3	-	pF
C _o	output capacitance	V _{I/O} = 0 V or 3.0 V	-	9	-	pF
I _{CC}	quiescent supply current	outputs disabled; V _{CC} = 2.5 V	-	40	-	μA
		outputs disabled; V _{CC} = 3.3 V	-	70	-	μA

4. Ordering information

Table 2: Ordering information

Type number	Package			
	Temperature range	Name	Description	Version
74ALVT162823DL	-40 °C to +85 °C	SSOP56	plastic shrink small outline package; 56 leads; body width 7.5 mm	SOT371-1
74ALVT162823DGG	-40 °C to +85 °C	TSSOP56	plastic thin shrink small outline package; 56 leads; body width 6.1 mm	SOT364-1

5. Functional diagram

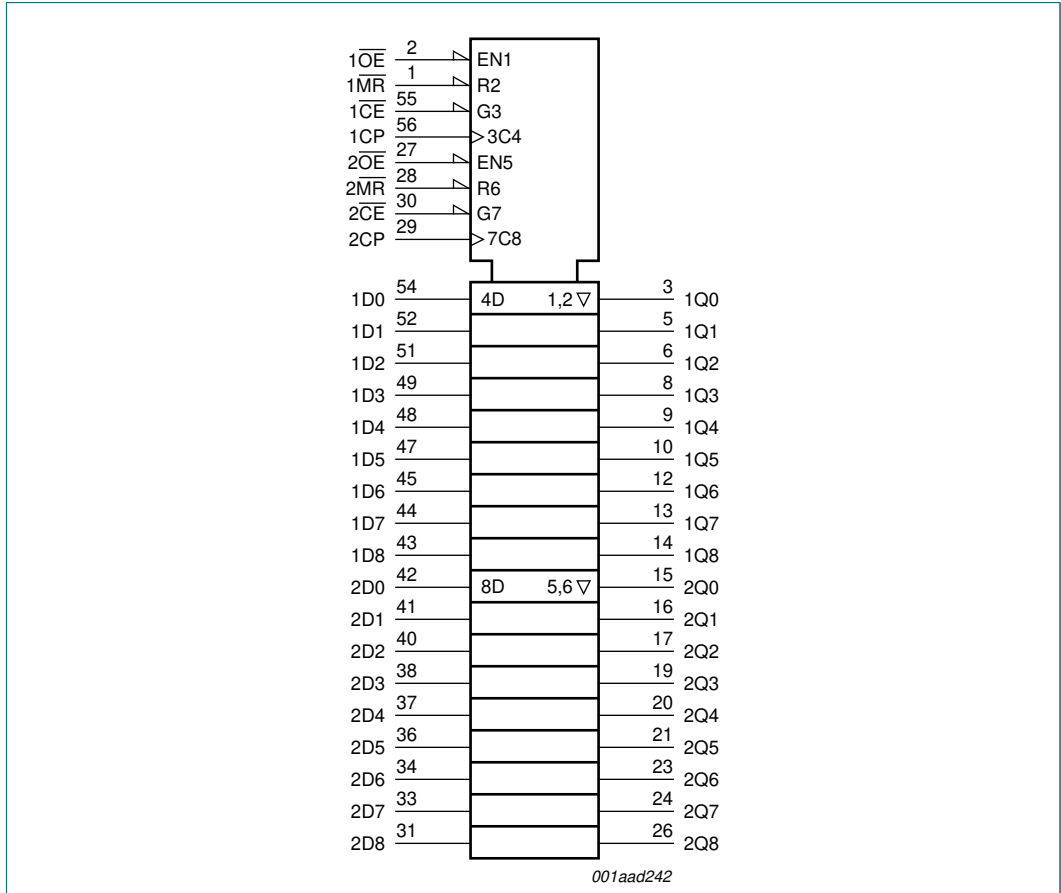

Fig 1. IEC logic symbol

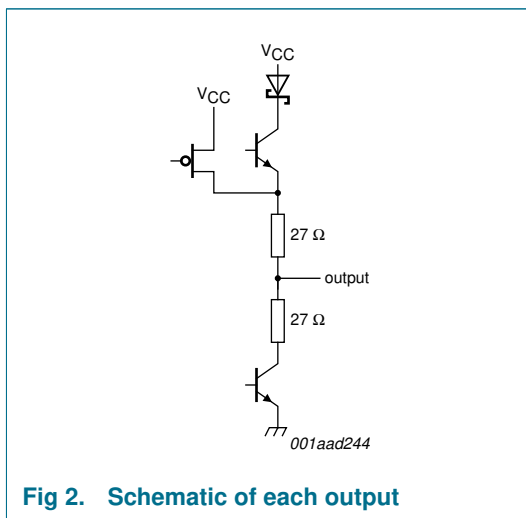

Fig 2. Schematic of each output

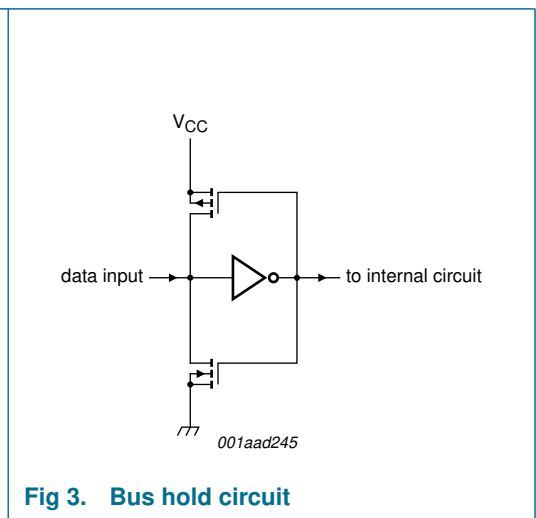

Fig 3. Bus hold circuit

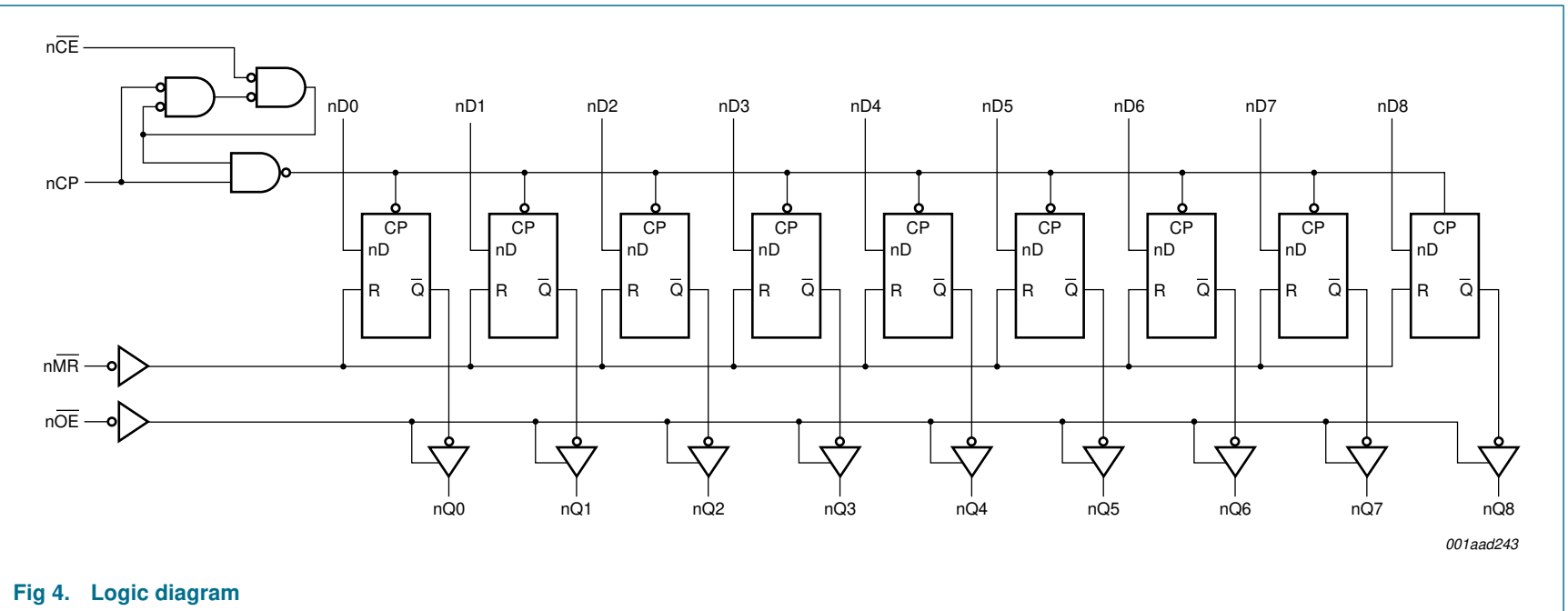

Fig 4. Logic diagram

6. Pinning information

6.1 Pinning

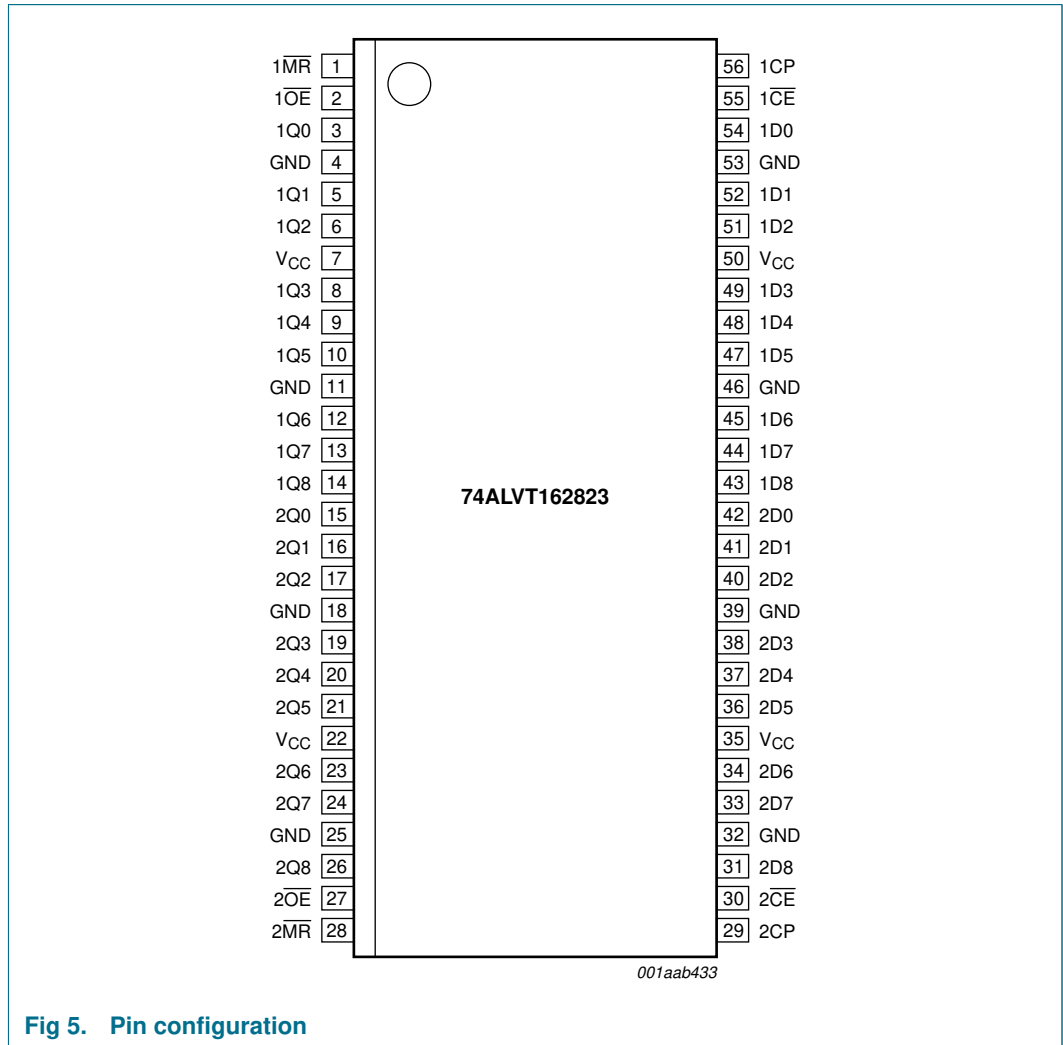

Fig 5. Pin configuration

6.2 Pin description

Table 3: Pin description

Symbol	Pin	Description
1MR	1	1 master reset input (active LOW)
1OE	2	1 output enable input (active LOW)
1Q0	3	1 data output 0
GND	4	ground (0 V)
1Q1	5	1 data output 1
1Q2	6	1 data output 2
V _{CC}	7	supply voltage
1Q3	8	1 data output 3

Table 3: Pin description ...continued

Symbol	Pin	Description
1Q4	9	1 data output 4
1Q5	10	1 data output 5
GND	11	ground (0 V)
1Q6	12	1 data output 6
1Q7	13	1 data output 7
1Q8	14	1 data output 8
2Q0	15	2 data output 0
2Q1	16	2 data output 1
2Q2	17	2 data output 2
GND	18	ground (0 V)
2Q3	19	2 data output 3
2Q4	20	2 data output 4
2Q5	21	2 data output 5
V _{CC}	22	supply voltage
2Q6	23	2 data output 6
2Q7	24	2 data output 7
GND	25	ground (0 V)
2Q8	26	2 data output 8
2 \overline{OE}	27	2 output enable input (active LOW)
2 \overline{MR}	28	2 master reset input (active LOW)
2CP	29	2 clock pulse input (active rising edge)
2 \overline{CE}	30	2 clock enable input (active LOW)
2D8	31	2 data input 8
GND	32	ground (0 V)
2D7	33	2 data input 7
2D6	34	2 data input 6
V _{CC}	35	supply voltage
2D5	36	2 data input 5
2D4	37	2 data input 4
2D3	38	2 data input 3
GND	39	ground (0 V)
2D2	40	2 data input 2
2D1	41	2 data input 1
2D0	42	2 data input 0
1D8	43	1 data input 8
1D7	44	1 data input 7
1D6	45	1 data input 6
GND	46	ground (0 V)
1D5	47	1 data input 5
1D4	48	1 data input 4
1D3	49	1 data input 3

Table 3: Pin description ...continued

Symbol	Pin	Description
V _{CC}	50	supply voltage
1D2	51	1 data input 2
1D1	52	1 data input 1
GND	53	ground (0 V)
1D0	54	1 data input 0
1 $\overline{\text{CE}}$	55	1 clock enable input (active LOW)
1CP	56	1 clock pulse input (active rising edge)

7. Functional description

7.1 Function table

Table 4: Function table [1]

Operating mode	Input					Output
	n $\overline{\text{OE}}$	n $\overline{\text{MR}}$	n $\overline{\text{CE}}$	nCP	nDx	nQx
Clear	L	L	X	X	X	L
Load and read data	L	H	L	\uparrow	h	H
					l	L
Hold	L	H	H	NC	X	NC
High-impedance	H	X	X	X	X	Z

- [1] H = HIGH voltage level;
h = HIGH voltage level one set-up time prior to the LOW-to-HIGH clock transition;
L = LOW voltage level;
l = LOW voltage level one set-up time prior to the LOW-to-HIGH clock transition;
NC = no change;
X = don't care;
Z = high-impedance OFF-state;
 \uparrow = LOW-to-HIGH clock transition;

8. Limiting values

Table 5: Limiting values

In accordance with the Absolute Maximum Rating System (IEC 60134).

Symbol	Parameter	Conditions	Min	Max	Unit
V _{CC}	supply voltage		-0.5	+4.6	V
V _I	input voltage		[1] -0.5	+7.0	V
V _O	output voltage	output in OFF-state or HIGH-state	[1] -0.5	+7.0	V
I _{IK}	input diode current	V _I < 0 V	-	-50	mA
I _{OK}	output diode current	V _O < 0 V	-	-50	mA

Table 5: Limiting values ...continued

In accordance with the Absolute Maximum Rating System (IEC 60134).

Symbol	Parameter	Conditions	Min	Max	Unit
I_O	output current	output in LOW-state	-	128	mA
		output in HIGH-state	-	-64	mA
T_{stg}	storage temperature		-65	+150	°C
T_j	junction temperature		[2]	150	°C

[1] The input and output negative voltage ratings may be exceeded if the input and output clamp current ratings are observed.

[2] The performance capability of a high-performance integrated circuit in conjunction with its thermal environment can create junction temperatures which are detrimental to reliability.

9. Recommended operating conditions

Table 6: Recommended operating conditions

Symbol	Parameter	Conditions	Min	Typ	Max	Unit
$V_{CC} = 2.5\text{ V}$						
V_{CC}	supply voltage		2.3	-	2.7	V
V_I	input voltage		0	-	5.5	V
V_{IH}	HIGH-level input voltage		1.7	-	-	V
V_{IL}	LOW-level input voltage		-	-	0.7	V
I_{OH}	HIGH-level output current		-	-	-8	mA
I_{OL}	LOW-level output current		-	-	12	mA
$\Delta t/\Delta V$	input transition rise or fall rate	outputs enabled	-	-	10	ns/V
T_{amb}	ambient temperature	in free air	-40	-	+85	°C
$V_{CC} = 3.3\text{ V}$						
V_{CC}	supply voltage		3.0	-	3.6	V
V_I	input voltage		0	-	5.5	V
V_{IH}	HIGH-level input voltage		2.0	-	-	V
V_{IL}	LOW-level input voltage		-	-	0.8	V
I_{OH}	HIGH-level output current		-	-	-12	mA
I_{OL}	LOW-level output current		-	-	12	mA
$\Delta t/\Delta V$	input transition rise or fall rate	outputs enabled	-	-	10	ns/V
T_{amb}	ambient temperature	in free air	-40	-	+85	°C

10. Static characteristics

Table 7: Static characteristics

At recommended operating conditions; voltages are referenced to GND (ground = 0 V); $T_{amb} = -40^{\circ}\text{C}$ to $+85^{\circ}\text{C}$.

Symbol	Parameter	Conditions	Min	Typ	Max	Unit	
$V_{CC} = 2.5\text{ V} \pm 0.2\text{ V}$ [1]							
V_{IK}	input diode voltage	$V_{CC} = 2.3\text{ V}$; $I_{IK} = -18\text{ mA}$	-	-0.85	-1.2	V	
V_{OH}	HIGH-level output voltage	$V_{CC} = 2.3\text{ V}$; $I_{OH} = -8\text{ mA}$	1.7	2.5	-	V	
V_{OL}	LOW-level output voltage	$V_{CC} = 2.3\text{ V}$; $I_{OL} = 12\text{ mA}$	-	0.3	0.5	V	
V_{RST}	power-up LOW-state output voltage	$V_{CC} = 2.7\text{ V}$; $I_O = 1\text{ mA}$; $V_I = V_{CC}$ or GND	[2]	-	0.2	0.55	V
I_{LI}	input leakage current	control pins	$V_{CC} = 2.7\text{ V}$; $V_I = \text{GND}$	-	0.1	± 1	μA
			$V_{CC} = 2.7\text{ V}$; $V_I = 5.5\text{ V}$	-	0.1	10	μA
	data pins	$V_{CC} = 2.7\text{ V}$; $V_I = 5.5\text{ V}$	[3]	-	0.1	10	μA
		$V_{CC} = 2.7\text{ V}$; $V_I = V_{CC}$	[3]	-	0.5	1	μA
		$V_{CC} = 2.7\text{ V}$; $V_I = 0\text{ V}$	[3]	-	+0.1	-5	μA
I_{OFF}	power-down output current	$V_{CC} = 0\text{ V}$; V_I or $V_O = 0\text{ V}$ to 4.5 V	-	+0.1	± 100	μA	
I_{HOLD}	bus hold current data inputs	$V_{CC} = 2.5\text{ V}$; $V_I = 0.7\text{ V}$	[4]	-	100	-	μA
		$V_{CC} = 2.5\text{ V}$; $V_I = 1.7\text{ V}$	[4]	-	-70	-	μA
I_{EX}	external current into output	output HIGH-state when $V_O > V_{CC}$; $V_O = 5.5\text{ V}$; $V_{CC} = 2.5\text{ V}$	-	10	125	μA	
I_{PU}	power-up 3-state output current	$V_{CC} \leq 1.2\text{ V}$; $V_O = 0.5\text{ V}$ to V_{CC} ; $V_I = \text{GND}$ or V_{CC}	[5]	-	1	± 100	μA
I_{PD}	power-down 3-state output current	$V_{CC} \leq 1.2\text{ V}$; $V_O = 0.5\text{ V}$ to V_{CC} ; $V_I = \text{GND}$ or V_{CC}	[5]	-	1	± 100	μA
I_{OZ}	3-state output current	$V_{CC} = 2.7\text{ V}$; $V_I = V_{IL}$ or V_{IH}					
		output HIGH-state; $V_O = 2.3\text{ V}$	-	0.5	5	μA	
		output LOW-state; $V_O = 0.5\text{ V}$	-	+0.5	-5	μA	
I_{CC}	quiescent supply current	$V_{CC} = 2.7\text{ V}$; $V_I = \text{GND}$ or V_{CC} ; $I_O = 0\text{ A}$					
		outputs HIGH-state	-	0.04	0.1	mA	
		outputs LOW-state	-	2.7	4.5	mA	
		outputs disabled	[6]	-	0.04	0.1	mA
ΔI_{CC}	additional quiescent supply current per input pin	$V_{CC} = 2.3\text{ V}$ to 2.7 V ; one input at $V_{CC} - 0.6\text{ V}$, other inputs at V_{CC} or GND	[7]	-	0.04	0.4	mA
C_i	input capacitance	$V_I = 0\text{ V}$ or V_{CC}	-	3	-	pF	
C_o	output capacitance	$V_{IO} = 0\text{ V}$ or 3.0 V	-	9	-	pF	
$V_{CC} = 3.3\text{ V} \pm 0.3\text{ V}$ [8]							
V_{IK}	input diode voltage	$V_{CC} = 3.0\text{ V}$; $I_{IK} = -18\text{ mA}$	-	-0.85	-1.2	V	
V_{OH}	HIGH-level output voltage	$V_{CC} = 3.0\text{ V}$; $I_{OH} = -12\text{ mA}$	2.0	2.3	-	V	
V_{OL}	LOW-level output voltage	$V_{CC} = 3.0\text{ V}$; $I_{OL} = 12\text{ mA}$	-	0.5	0.8	V	
V_{RST}	power-up LOW-state output voltage	$V_{CC} = 3.6\text{ V}$; $I_O = 1\text{ mA}$; $V_I = V_{CC}$ or GND	[2]	-	-	0.55	V

Table 7: Static characteristics ...continuedAt recommended operating conditions; voltages are referenced to GND (ground = 0 V); $T_{amb} = -40\text{ }^{\circ}\text{C}$ to $+85\text{ }^{\circ}\text{C}$.

Symbol	Parameter	Conditions	Min	Typ	Max	Unit	
I_{LI}	input leakage current	control pins					
		$V_{CC} = 3.6\text{ V}$; $V_I = V_{CC}$ or GND	-	0.1	± 1	μA	
		$V_{CC} = 0\text{ V}$ or 3.6 V ; $V_I = 5.5\text{ V}$	-	0.1	10	μA	
	data pins	$V_{CC} = 3.6\text{ V}$; $V_I = 5.5\text{ V}$	[3]	-	0.1	10	μA
		$V_{CC} = 3.6\text{ V}$; $V_I = V_{CC}$	[3]	-	0.5	1	μA
$V_{CC} = 3.6\text{ V}$; $V_I = 0\text{ V}$		[3]	-	+0.1	-5	μA	
I_{OFF}	power-down output current	$V_{CC} = 0\text{ V}$; V_I or $V_O = 0\text{ V}$ to 4.5 V	-	0.1	± 100	μA	
I_{HOLD}	bus hold current data inputs	$V_{CC} = 3\text{ V}$; $V_I = 0.8\text{ V}$	[9]	75	130	-	μA
		$V_{CC} = 3\text{ V}$; $V_I = 2.0\text{ V}$	[9]	-75	-140	-	μA
		$V_{CC} = 3.6\text{ V}$; $V_I = 0\text{V}$ to 3.6 V	[9]	± 500	-	-	μA
I_{EX}	external current into output	output HIGH-state when $V_O > V_{CC}$; $V_O = 5.5\text{ V}$; $V_{CC} = 3.0\text{ V}$	-	10	125	μA	
I_{PU}	power-up 3-state output current	$V_{CC} \leq 1.2\text{ V}$; $V_O = 0.5\text{ V}$ to V_{CC} ; $V_I = \text{GND}$ or V_{CC}	[10]	-	1	± 100	μA
I_{PD}	power-down 3-state output current	$V_{CC} \leq 1.2\text{ V}$; $V_O = 0.5\text{ V}$ to V_{CC} ; $V_I = \text{GND}$ or V_{CC}	[10]	-	1	± 100	μA
I_{OZ}	3-state output current	$V_{CC} = 3.6\text{ V}$; $V_I = V_{IL}$ or V_{IH}					
		output HIGH-state; $V_O = 3.0\text{ V}$	-	0.5	5	μA	
		output LOW-state; $V_O = 0.5\text{ V}$	-	+0.5	-5	μA	
I_{CC}	quiescent supply current	$V_{CC} = 3.6\text{ V}$; $V_I = \text{GND}$ or V_{CC} ; $I_O = 0\text{ A}$					
		outputs HIGH-state	-	0.05	0.1	mA	
		outputs LOW-state	-	3.9	5.5	mA	
		outputs disabled	[6]	-	0.06	0.1	mA
ΔI_{CC}	additional quiescent supply current per input pin	$V_{CC} = 3\text{ V}$ to 3.6 V ; one input at $V_{CC} - 0.6\text{ V}$, other inputs at V_{CC} or GND	[7]	-	0.04	0.4	mA
C_i	input capacitance	$V_I = 0\text{ V}$ or V_{CC}	-	3	-	pF	
C_o	output capacitance	$V_{IO} = 0\text{ V}$ or 3.0 V	-	9	-	pF	

[1] All typical values are at $V_{CC} = 2.5\text{ V}$ and $T_{amb} = 25\text{ }^{\circ}\text{C}$.

[2] For valid test results, data must not be loaded into the flip-flops (or latches) after applying power.

[3] Unused pins at V_{CC} or GND.

[4] Not guaranteed.

[5] This parameter is valid for any V_{CC} between 0 V and 1.2 V with a transition time of up to 10 ms . From $V_{CC} = 1.2\text{ V}$ to $V_{CC} = 2.5\text{ V} \pm 0.2\text{ V}$ a transition time of $100\text{ }\mu\text{s}$ is permitted. This parameter is valid for $T_{amb} = 25\text{ }^{\circ}\text{C}$ only.[6] I_{CC} is measured with outputs pulled up to V_{CC} or pulled down to ground.[7] This is the increase in supply current for each input at the specified voltage level other than V_{CC} or GND.[8] All typical values are at $V_{CC} = 3.3\text{ V}$ and $T_{amb} = 25\text{ }^{\circ}\text{C}$.

[9] This is the bus hold overdrive current required to force the input to the opposite logic state.

[10] This parameter is valid for any V_{CC} between 0 V and 1.2 V with a transition time of up to 10 ms . From $V_{CC} = 1.2\text{ V}$ to $V_{CC} = 3.3\text{ V} \pm 0.3\text{ V}$ a transition time of $100\text{ }\mu\text{s}$ is permitted. This parameter is valid for $T_{amb} = 25\text{ }^{\circ}\text{C}$ only.

11. Dynamic characteristics

Table 8: Dynamic characteristics

Voltages are referenced to GND (ground = 0 V); for test circuit see [Figure 11](#);

$T_{amb} = -40\text{ }^{\circ}\text{C}$ to $+85\text{ }^{\circ}\text{C}$.

Symbol	Parameter	Conditions	Min	Typ	Max	Unit
$V_{CC} = 2.5\text{ V} \pm 0.2\text{ V}$ [1]						
t _{PLH}	propagation delay nCP to nQx	see Figure 6	2.1	3.7	5.8	ns
t _{PHL}	propagation delay					
	nCP to nQx	see Figure 6	2.0	2.8	4.6	ns
	nMR to nQx	see Figure 8	2.0	3.0	4.6	ns
t _{PZH}	output enable time to HIGH-level	see Figure 9	2.8	4.4	6.6	ns
t _{PZL}	output enable time to LOW-level	see Figure 10	2.0	3.4	5.2	ns
t _{PHZ}	output disable time from HIGH-level	see Figure 9	2.3	3.2	4.6	ns
t _{PLZ}	output disable time from LOW-level	see Figure 10	2.0	2.5	3.5	ns
t _{su(H)}	set-up time HIGH					
	nDx to nCP	see Figure 7	1.0	0.5	-	ns
	n $\overline{\text{CE}}$ to nCP	see Figure 7	1.0	0.2	-	ns
t _{su(L)}	set-up time LOW					
	nDx to nCP	see Figure 7	2.0	1.3	-	ns
	n $\overline{\text{CE}}$ to nCP	see Figure 7	+0.5	-0.1	-	ns
t _{h(H)}	hold time HIGH					
	nDx to nCP	see Figure 7	+0.1	-1.4	-	ns
	n $\overline{\text{CE}}$ to nCP	see Figure 7	1.0	0.2	-	ns
t _{h(L)}	hold time LOW					
	nDx to nCP	see Figure 7	+0.1	-0.5	-	ns
	n $\overline{\text{CE}}$ to nCP	see Figure 7	+1.0	-0.1	-	ns
t _{WH}	pulse width HIGH nCP	see Figure 6	2.0	0.8	-	ns
t _{WL}	pulse width LOW					
	nCP	see Figure 6	3.0	2.1	-	ns
	nMR	see Figure 8	2.0	0.8	-	ns
t _{rec}	recovery time nMR to nCP	see Figure 8	2.3	1.3	-	ns
$V_{CC} = 3.3\text{ V} \pm 0.3\text{ V}$ [2]						
t _{PLH}	propagation delay nCP to nQx	see Figure 6	1.8	2.9	4.4	ns
t _{PHL}	propagation delay					
	nCP to nQx	see Figure 6	1.6	2.3	3.6	ns
	nMR to nQx	see Figure 8	1.8	2.5	3.7	ns
t _{PZH}	output enable time to HIGH-level	see Figure 9	2.0	3.5	5.2	ns
t _{PZL}	output enable time to LOW-level	see Figure 10	1.7	2.8	3.8	ns
t _{PHZ}	output disable time from HIGH-level	see Figure 9	2.4	3.5	4.7	ns
t _{PLZ}	output disable time from LOW-level	see Figure 10	1.9	2.8	3.8	ns

Table 8: Dynamic characteristics ...continued

Voltages are referenced to GND (ground = 0 V); for test circuit see [Figure 11](#);
 $T_{amb} = -40\text{ }^{\circ}\text{C}$ to $+85\text{ }^{\circ}\text{C}$.

Symbol	Parameter	Conditions	Min	Typ	Max	Unit
$t_{su(H)}$	set-up time HIGH					
	nDx to nCP	see Figure 7	1.0	0.5	-	ns
	n $\overline{\text{CE}}$ to nCP	see Figure 7	1.0	0.1	-	ns
$t_{su(L)}$	set-up time LOW					
	nDx to nCP	see Figure 7	1.6	1.1	-	ns
	n $\overline{\text{CE}}$ to nCP	see Figure 7	+0.5	-0.5	-	ns
$t_{h(H)}$	hold time HIGH					
	nDx to nCP	see Figure 7	+0.1	-0.5	-	ns
	n $\overline{\text{CE}}$ to nCP	see Figure 7	1.0	-0.1	-	ns
$t_{h(L)}$	hold time LOW					
	nDx to nCP	see Figure 7	+0.1	-0.7	-	ns
	n $\overline{\text{CE}}$ to nCP	see Figure 7	1.0	0.5	-	ns
t_{WH}	pulse width HIGH nCP	see Figure 6	1.5	0.7	-	ns
t_{WL}	pulse width LOW					
	nCP	see Figure 6	2.5	1.4	-	ns
	n $\overline{\text{MR}}$	see Figure 8	2.0	1.5	-	ns
t_{rec}	recovery time n $\overline{\text{MR}}$ to nCP	see Figure 8	2.0	1.1	-	ns

[1] All typical values are measured at $V_{CC} = 2.5\text{ V}$ and $T_{amb} = 25\text{ }^{\circ}\text{C}$.

[2] All typical values are measured at $V_{CC} = 3.3\text{ V}$ and $T_{amb} = 25\text{ }^{\circ}\text{C}$.

12. Waveforms

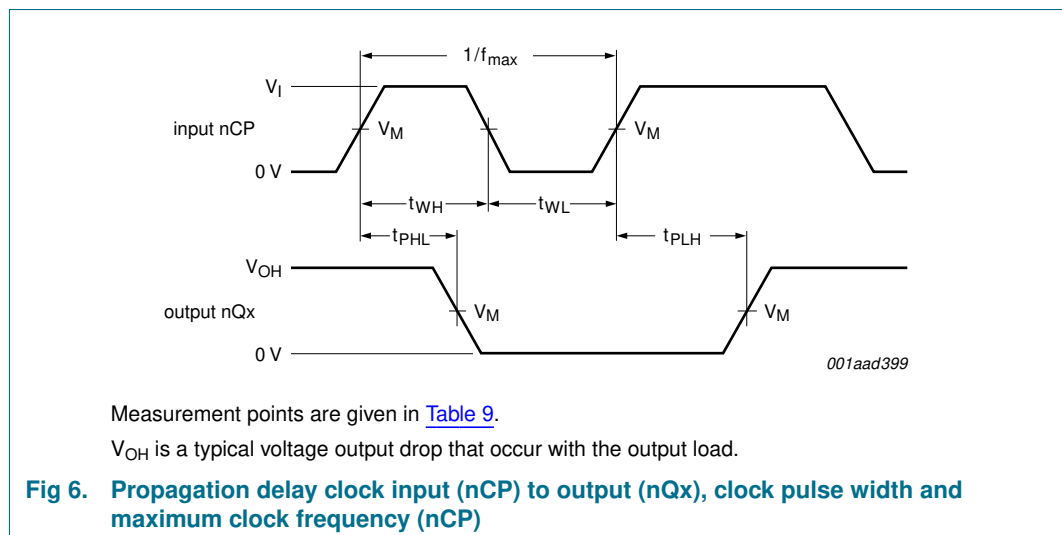

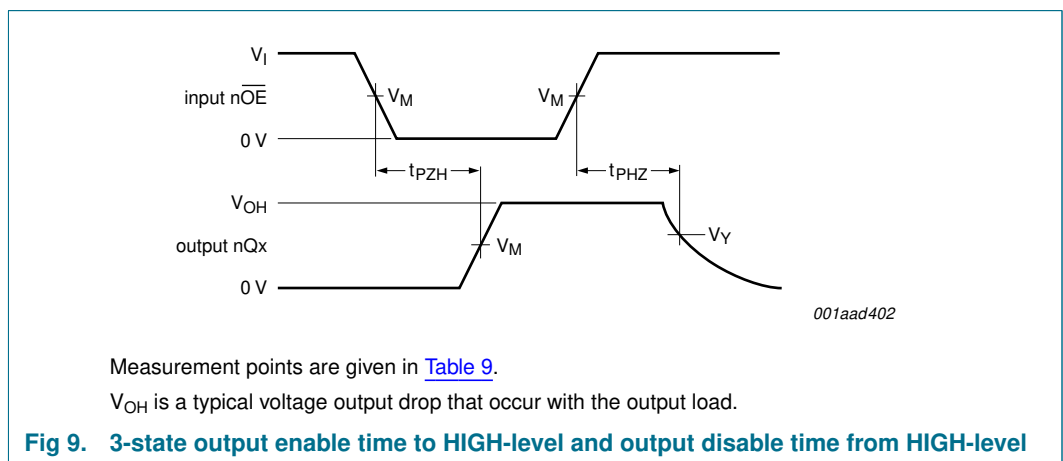
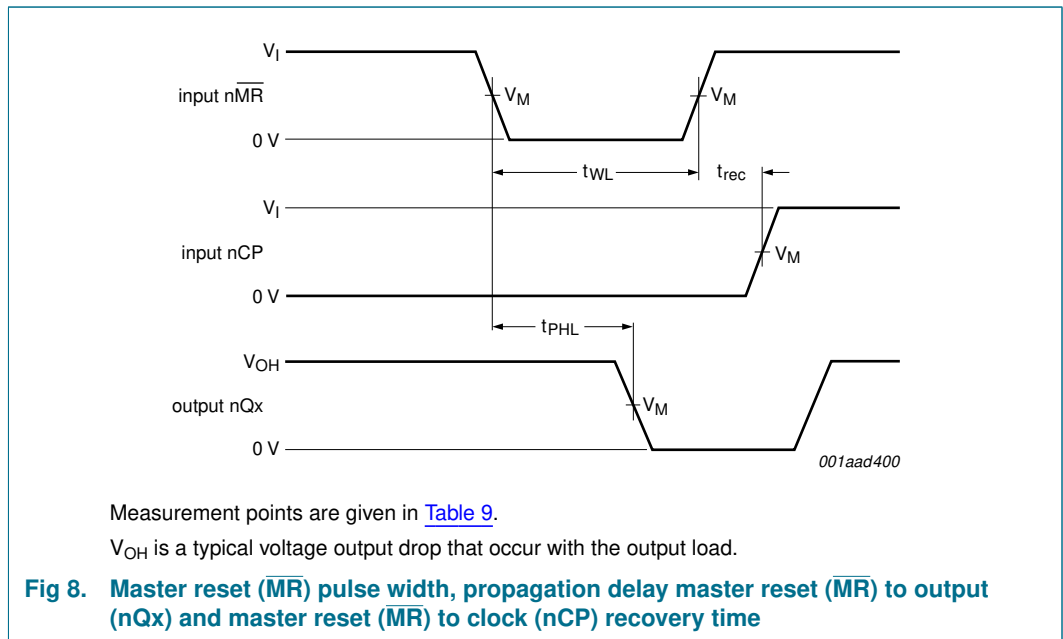
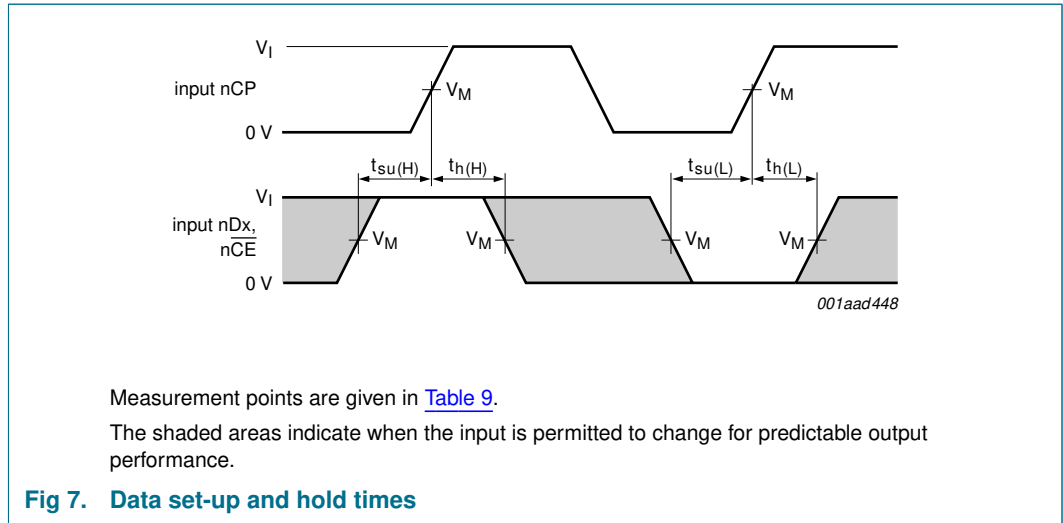

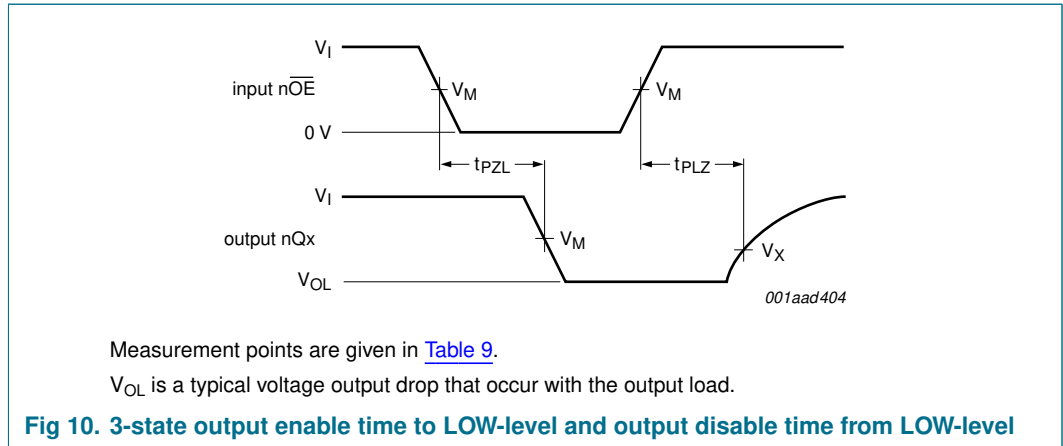

Table 9: Measurement points

Supply voltage	Input	Output		
	V_M	V_M	V_X	V_Y
$\geq 3\text{ V}$	1.5 V	1.5 V	$V_{OL} + 0.3\text{ V}$	$V_{OH} - 0.3\text{ V}$
$\leq 2.7\text{ V}$	$0.5 \times V_{CC}$	$0.5 \times V_{CC}$	$V_{OL} + 0.3\text{ V}$	$V_{OH} - 0.3\text{ V}$

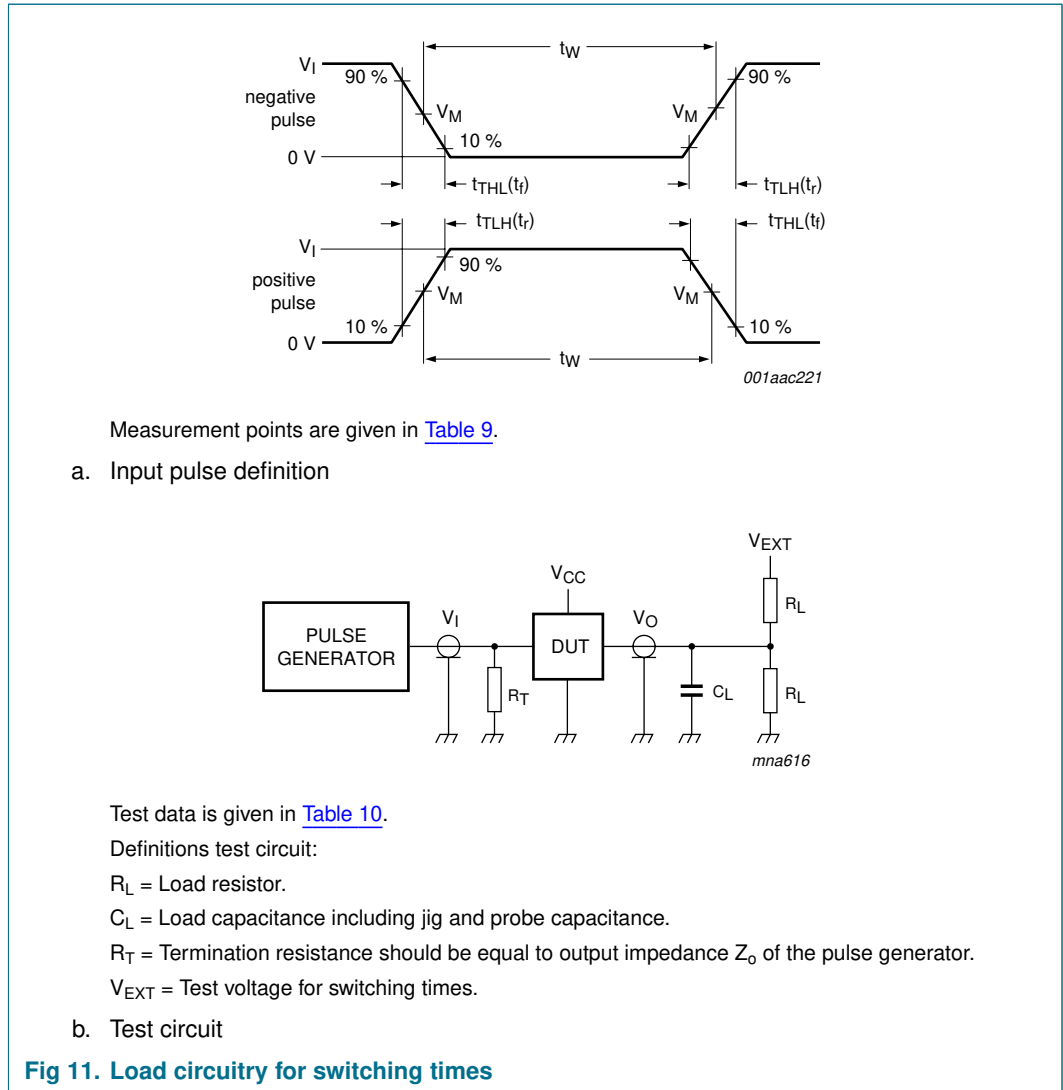

Table 10: Test data

Input				Load		V _{EXT}		
V _I	f _i	t _w	t _r , t _f	C _L	R _L	t _{PLZ} , t _{PZL}	t _{PLH} , t _{PHL}	t _{PHZ} , t _{PZH}
3.0 V or V _{CC} whichever is less	≤ 10 MHz	500 ns	≤ 2.5 ns	50 pF	500 Ω	6 V or 2 × V _{CC}	open	GND

13. Package outline

SSOP56: plastic shrink small outline package; 56 leads; body width 7.5 mm

SOT371-1

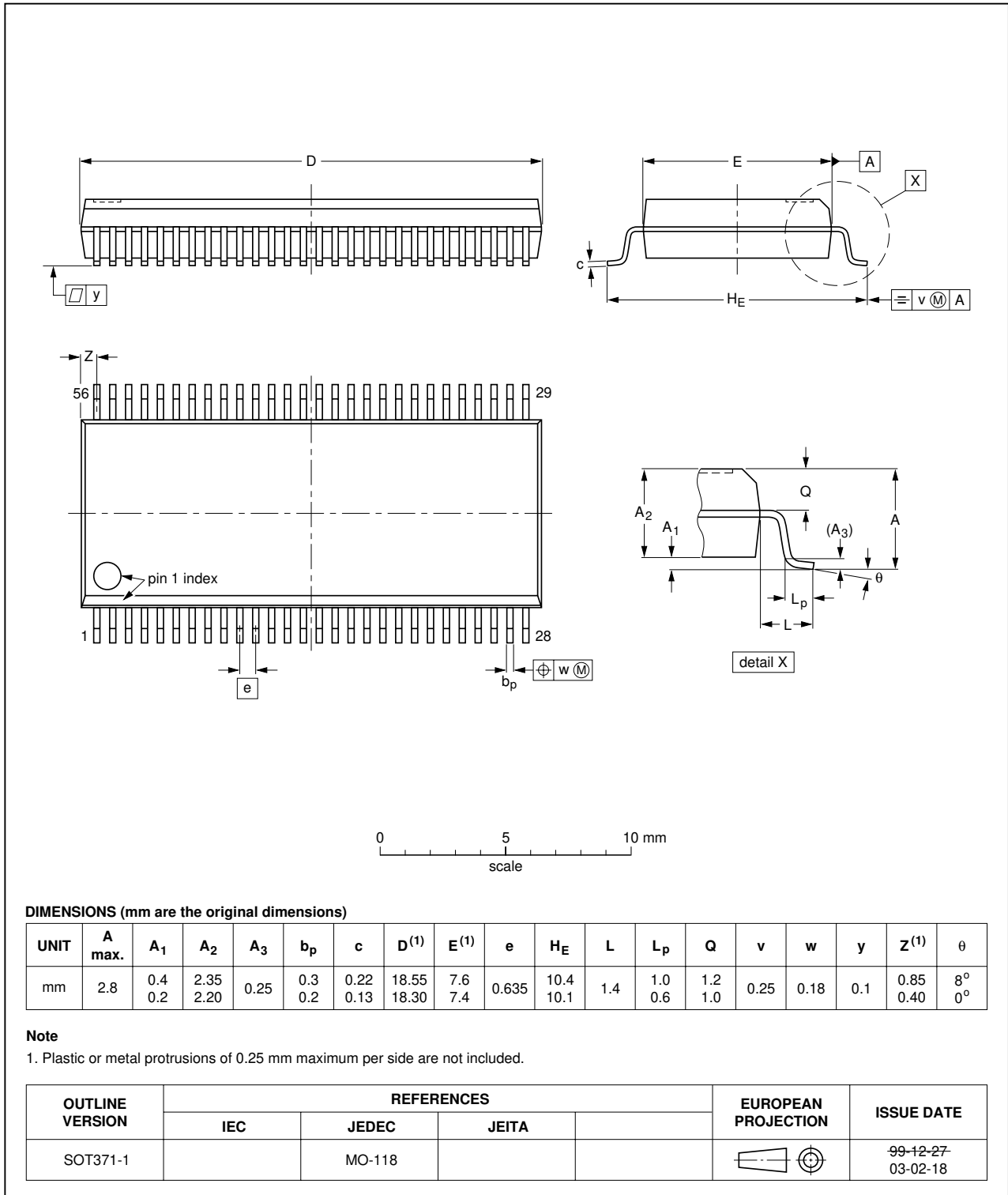

Fig 12. Package outline SOT371-1 (SSOP56)

TSSOP56: plastic thin shrink small outline package; 56 leads; body width 6.1 mm

SOT364-1

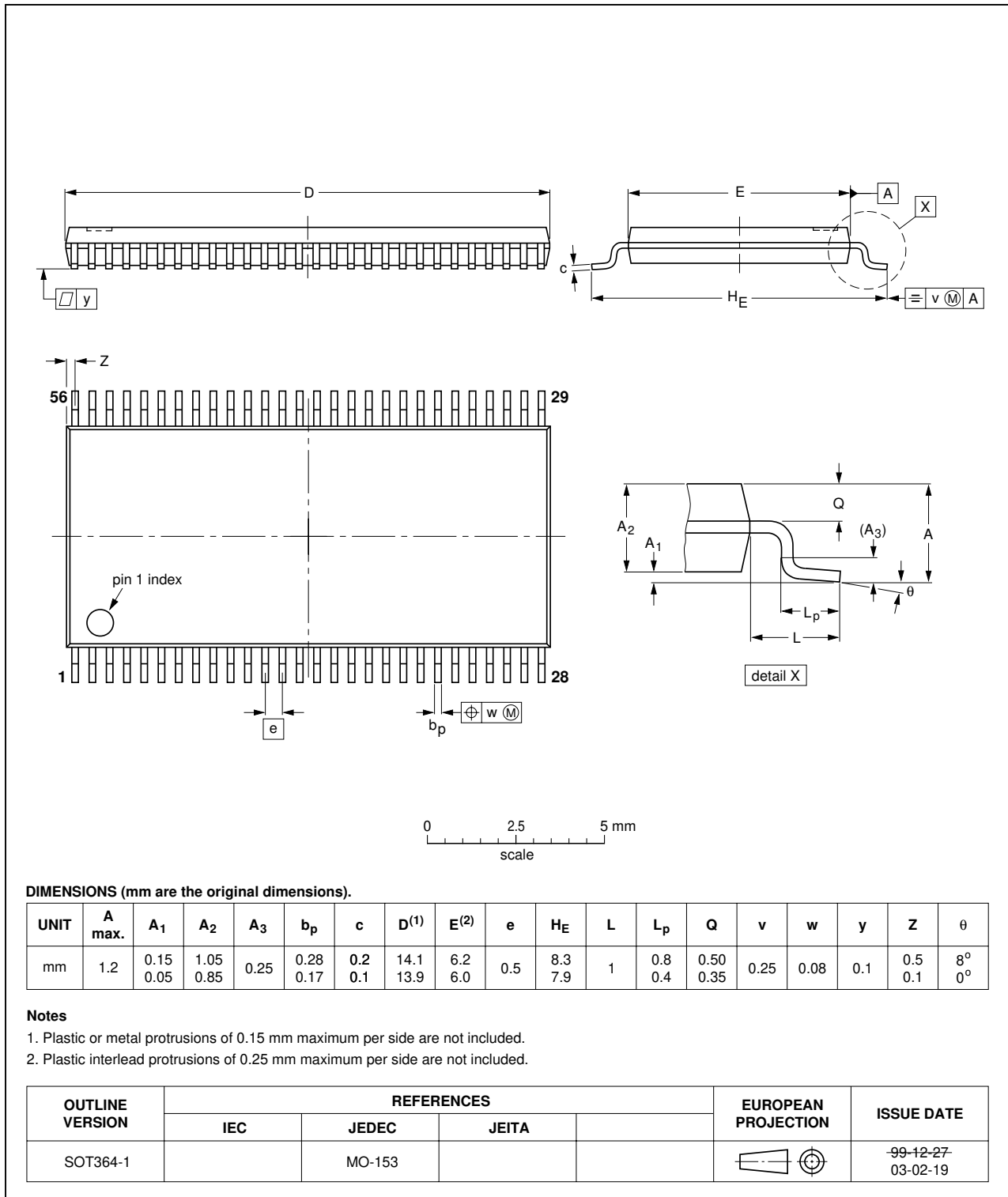

Fig 13. Package outline SOT364-1 (TSSOP56)

14. Revision history

Table 11: Revision history

Document ID	Release date	Data sheet status	Change notice	Doc. number	Supersedes
74ALVT162823_2	20050811	Product data sheet	-	-	74ALVT162823_1
Modifications:					
					<ul style="list-style-type: none">• The format of this data sheet has been redesigned to comply with the new presentation and information standard of Philips Semiconductors.• Section 2 “Features”: modified ‘Jedec Std 17’ into ‘JESD78’• Table 1 and Table 8: changed propagation delays.
74ALVT162823_1	19980827	Product specification	-	9397 750 03577	-

15. Data sheet status

Level	Data sheet status ^[1]	Product status ^[2] ^[3]	Definition
I	Objective data	Development	This data sheet contains data from the objective specification for product development. Philips Semiconductors reserves the right to change the specification in any manner without notice.
II	Preliminary data	Qualification	This data sheet contains data from the preliminary specification. Supplementary data will be published at a later date. Philips Semiconductors reserves the right to change the specification without notice, in order to improve the design and supply the best possible product.
III	Product data	Production	This data sheet contains data from the product specification. Philips Semiconductors reserves the right to make changes at any time in order to improve the design, manufacturing and supply. Relevant changes will be communicated via a Customer Product/Process Change Notification (CPCN).

[1] Please consult the most recently issued data sheet before initiating or completing a design.

[2] The product status of the device(s) described in this data sheet may have changed since this data sheet was published. The latest information is available on the Internet at URL <http://www.semiconductors.philips.com>.

[3] For data sheets describing multiple type numbers, the highest-level product status determines the data sheet status.

16. Definitions

Short-form specification — The data in a short-form specification is extracted from a full data sheet with the same type number and title. For detailed information see the relevant data sheet or data handbook.

Limiting values definition — Limiting values given are in accordance with the Absolute Maximum Rating System (IEC 60134). Stress above one or more of the limiting values may cause permanent damage to the device. These are stress ratings only and operation of the device at these or at any other conditions above those given in the Characteristics sections of the specification is not implied. Exposure to limiting values for extended periods may affect device reliability.

Application information — Applications that are described herein for any of these products are for illustrative purposes only. Philips Semiconductors make no representation or warranty that such applications will be suitable for the specified use without further testing or modification.

17. Disclaimers

Life support — These products are not designed for use in life support appliances, devices, or systems where malfunction of these products can reasonably be expected to result in personal injury. Philips Semiconductors

19. Contact information

For additional information, please visit: <http://www.semiconductors.philips.com>

For sales office addresses, send an email to: sales.addresses@www.semiconductors.philips.com

customers using or selling these products for use in such applications do so at their own risk and agree to fully indemnify Philips Semiconductors for any damages resulting from such application.

Right to make changes — Philips Semiconductors reserves the right to make changes in the products - including circuits, standard cells, and/or software - described or contained herein in order to improve design and/or performance. When the product is in full production (status 'Production'), relevant changes will be communicated via a Customer Product/Process Change Notification (CPCN). Philips Semiconductors assumes no responsibility or liability for the use of any of these products, conveys no license or title under any patent, copyright, or mask work right to these products, and makes no representations or warranties that these products are free from patent, copyright, or mask work right infringement, unless otherwise specified.

18. Trademarks

Notice — All referenced brands, product names, service names and trademarks are the property of their respective owners.

20. Contents

1	General description	1
2	Features	1
3	Quick reference data	2
4	Ordering information	2
5	Functional diagram	3
6	Pinning information	5
6.1	Pinning	5
6.2	Pin description	5
7	Functional description	7
7.1	Function table	7
8	Limiting values	7
9	Recommended operating conditions	8
10	Static characteristics	9
11	Dynamic characteristics	11
12	Waveforms	12
13	Package outline	16
14	Revision history	18
15	Data sheet status	19
16	Definitions	19
17	Disclaimers	19
18	Trademarks	19
19	Contact information	19



© Koninklijke Philips Electronics N.V. 2005

All rights are reserved. Reproduction in whole or in part is prohibited without the prior written consent of the copyright owner. The information presented in this document does not form part of any quotation or contract, is believed to be accurate and reliable and may be changed without notice. No liability will be accepted by the publisher for any consequence of its use. Publication thereof does not convey nor imply any license under patent- or other industrial or intellectual property rights.

Date of release: 11 August 2005
Document number: 74ALVT162823_2

Published in The Netherlands