



Chipsmall Limited consists of a professional team with an average of over 10 year of expertise in the distribution of electronic components. Based in Hongkong, we have already established firm and mutual-benefit business relationships with customers from,Europe,America and south Asia,supplying obsolete and hard-to-find components to meet their specific needs.

With the principle of “Quality Parts,Customers Priority,Honest Operation,and Considerate Service”,our business mainly focus on the distribution of electronic components. Line cards we deal with include Microchip,ALPS,ROHM,Xilinx,Pulse,ON,Everlight and Freescale. Main products comprise IC,Modules,Potentiometer,IC Socket,Relay,Connector.Our parts cover such applications as commercial,industrial, and automotives areas.

We are looking forward to setting up business relationship with you and hope to provide you with the best service and solution. Let us make a better world for our industry!



Contact us

Tel: +86-755-8981 8866 Fax: +86-755-8427 6832

Email & Skype: info@chipsmall.com Web: www.chipsmall.com

Address: A1208, Overseas Decoration Building, #122 Zhenhua RD., Futian, Shenzhen, China



74AVCH16T245

16-bit dual supply translating transceiver with configurable voltage translation; 3-state

Rev. 02 — 29 March 2010

Product data sheet

1. General description

The 74AVCH16T245 is a 16-bit transceiver with bidirectional level voltage translation and 3-state outputs. The device can be used as two 8-bit transceivers or as a 16-bit transceiver. It has dual supplies ($V_{CC(A)}$ and $V_{CC(B)}$) for voltage translation and two 8-bit input-output ports (nAn , nBn) each with its own output enable (\overline{nOE}) and send/receive ($nDIR$) input for direction control. $V_{CC(A)}$ and $V_{CC(B)}$ can be independently supplied at any voltage between 0.8 V and 3.6 V making the device suitable for low voltage translation between any of the following voltages: 0.8 V, 1.2 V, 1.5 V, 1.8 V, 2.5 V and 3.3 V. A HIGH on $nDIR$ selects transmission from nAn to nBn while a LOW on $nDIR$ selects transmission from nBn to nAn . A HIGH on \overline{nOE} causes the outputs to assume a high-impedance OFF-state

The device is fully specified for partial power-down applications using I_{OFF} . The I_{OFF} circuitry disables the output, preventing any damaging backflow current through the device when it is powered down. In suspend mode when either $V_{CC(A)}$ or $V_{CC(B)}$ are at GND level, both A and B outputs are in the high-impedance OFF-state. The bus-hold circuitry on the powered-up side always stays active.

The 74AVCH16T245 has active bus hold circuitry which is provided to hold unused or floating data inputs at a valid logic level. This feature eliminates the need for external pull-up or pull-down resistors.

2. Features and benefits

- Wide supply voltage range:
 - ◆ $V_{CC(A)}$: 0.8 V to 3.6 V
 - ◆ $V_{CC(B)}$: 0.8 V to 3.6 V
- Complies with JEDEC standards:
 - ◆ JESD8-12 (0.8 V to 1.3 V)
 - ◆ JESD8-11 (0.9 V to 1.65 V)
 - ◆ JESD8-7 (1.2 V to 1.95 V)
 - ◆ JESD8-5 (1.8 V to 2.7 V)
 - ◆ JESD8-B (2.7 V to 3.6 V)
- ESD protection:
 - ◆ HBM JESD22-A114F Class 3B exceeds 8000 V
 - ◆ MM JESD22-A115-A exceeds 200 V
 - ◆ CDM JESD22-C101D exceeds 1000 V
- Maximum data rates:
 - ◆ 380 Mbit/s (\geq 1.8 V to 3.3 V translation)



- ◆ 200 Mbit/s (≥ 1.1 V to 3.3 V translation)
- ◆ 200 Mbit/s (≥ 1.1 V to 2.5 V translation)
- ◆ 200 Mbit/s (≥ 1.1 V to 1.8 V translation)
- ◆ 150 Mbit/s (≥ 1.1 V to 1.5 V translation)
- ◆ 100 Mbit/s (≥ 1.1 V to 1.2 V translation)
- Suspend mode
- Bus hold on data inputs
- Latch-up performance exceeds 100 mA per JESD 78 Class II
- Inputs accept voltages up to 3.6 V
- I_{OFF} circuitry provides partial Power-down mode operation
- Multiple package options
- Specified from -40 °C to $+85$ °C and -40 °C to $+125$ °C

3. Ordering information

Table 1. Ordering information

Type number	Package			Version
	Temperature range	Name	Description	
74AVCH16T245DGG	-40 °C to $+125$ °C	TSSOP48	plastic thin shrink small outline package; 48 leads; body width 6.1 mm	SOT362-1
74AVCH16T245DGV	-40 °C to $+125$ °C	TSSOP48 ^[1]	plastic thin shrink small outline package; 48 leads; body width 4.4 mm; lead pitch 0.4 mm	SOT480-1
74AVCH16T245EV	-40 °C to $+125$ °C	VFBGA56	plastic very thin fine-pitch ball grid array package; 56 balls; body $4.5 \times 7 \times 0.65$ mm	SOT702-1
74AVCH16T245BQ	-40 °C to $+125$ °C	HXQFN60U	plastic thermal enhanced extremely thin quad flat package; no leads; 60 terminals; UTLP based; body $4 \times 6 \times 0.5$ mm	SOT1134-1

[1] Also known as TVSOP48.

4. Functional diagram

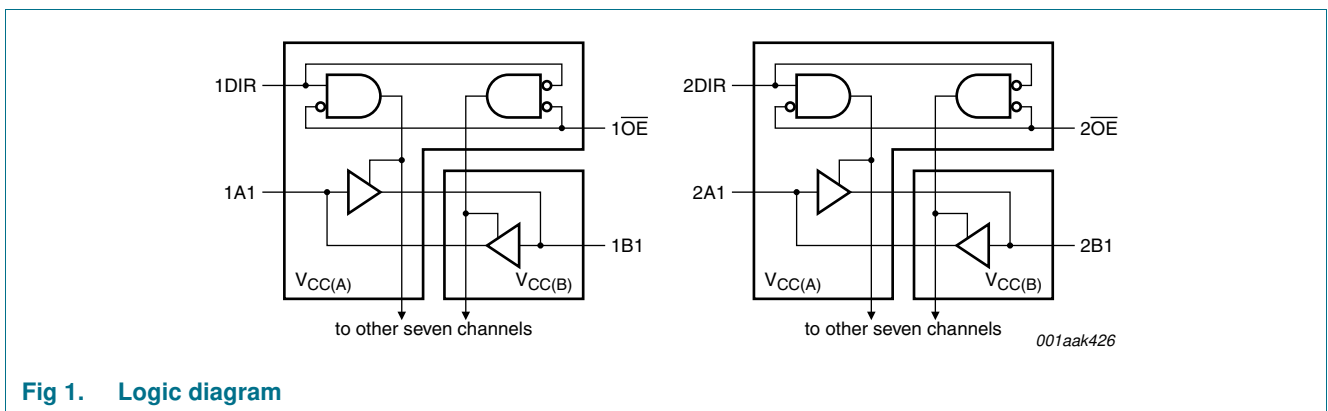

Fig 1. Logic diagram

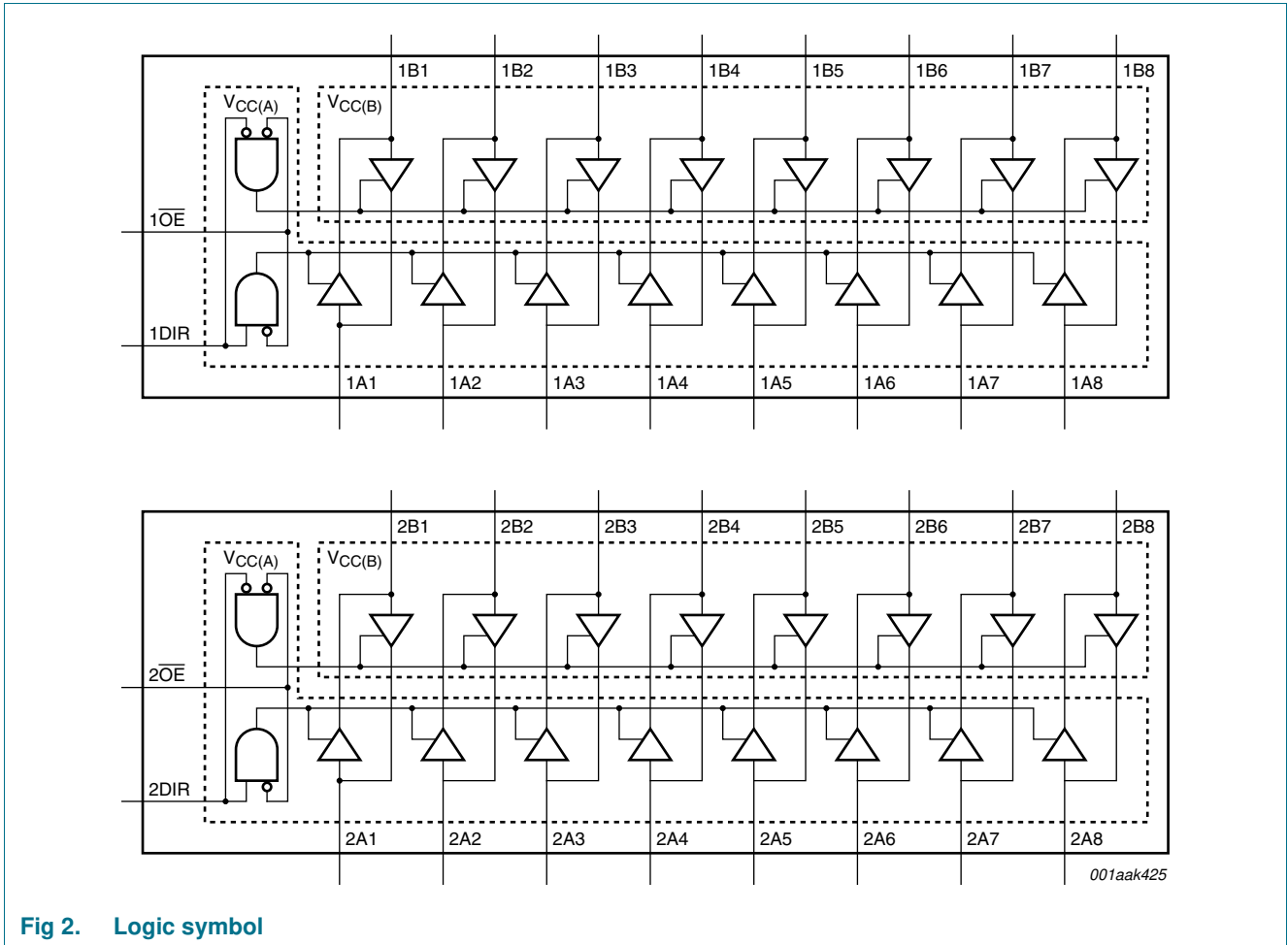
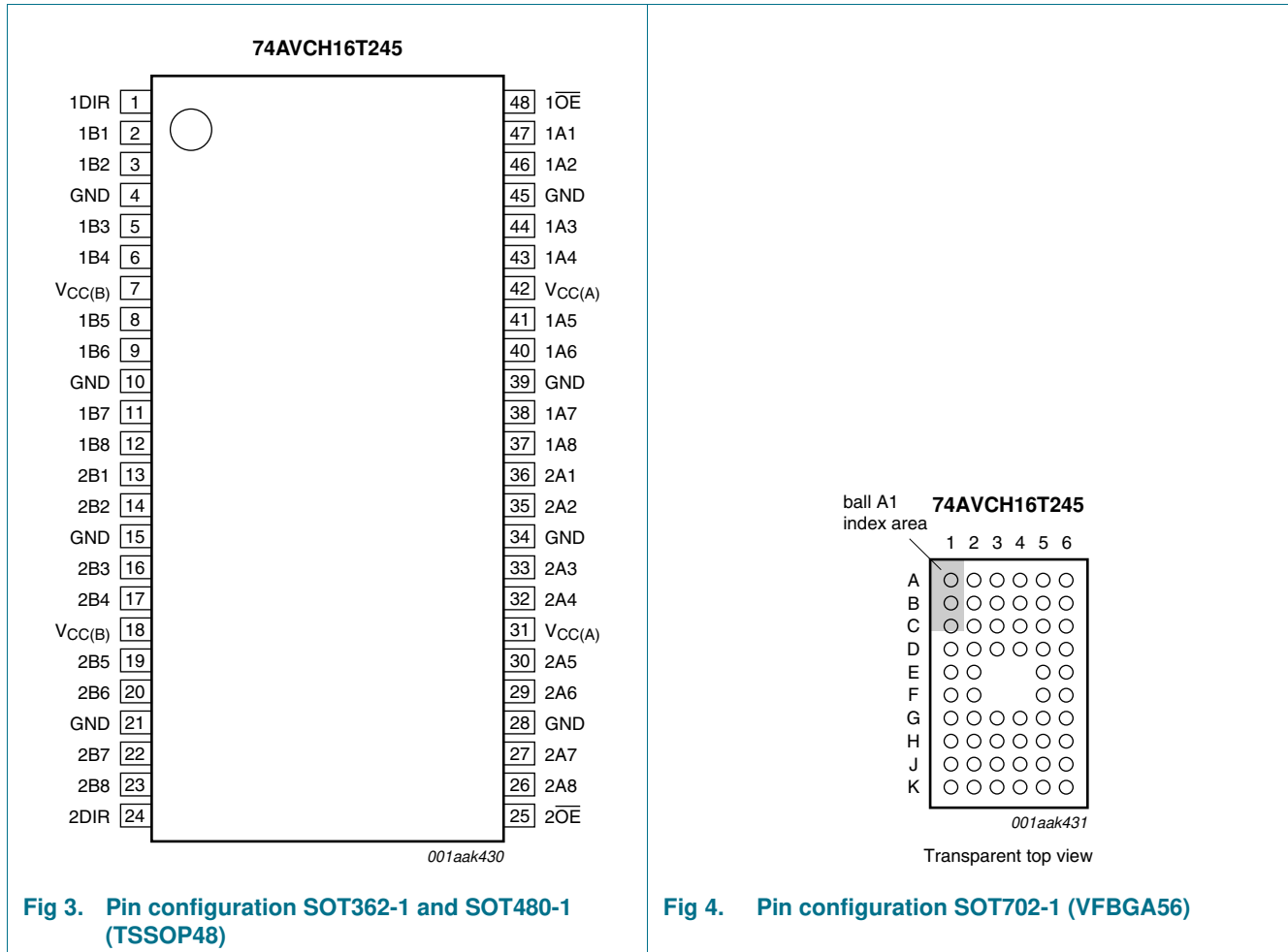
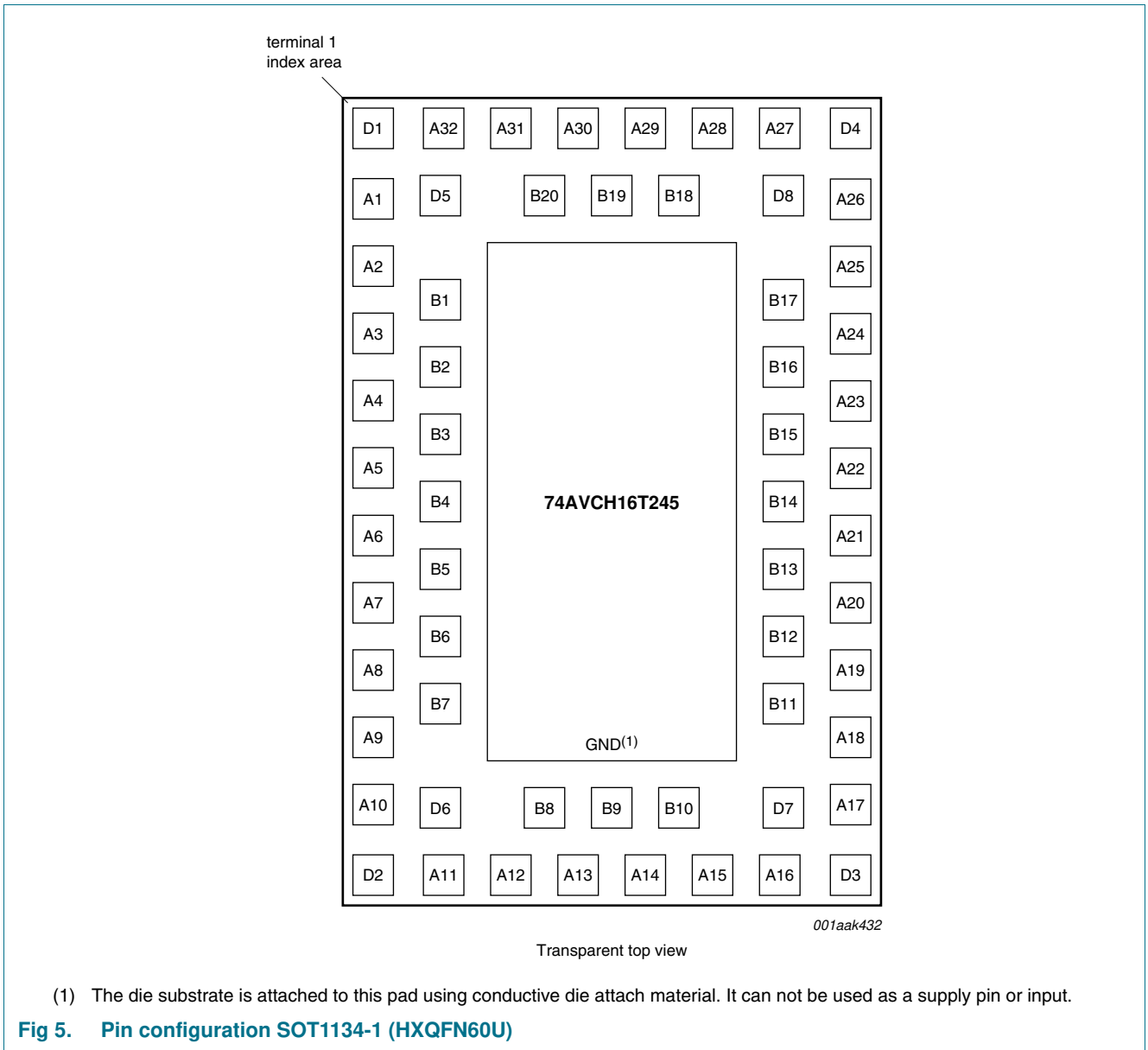

Fig 2. Logic symbol

5. Pinning information

5.1 Pinning





5.2 Pin description

Table 2. Pin description

Symbol	Pin			Description
	SOT362-1 and SOT480-1	SOT702-1	SOT1134-1	
1DIR, 2DIR	1, 24	A1, K1	A30, A13	direction control
1B1 to 1B8	2, 3, 5, 6, 8, 9, 11, 12	B2, B1, C2, C1, D2, D1, E2, E1	B20, A31, D5, D1, A2, B2, B3, A5	data input or output
2B1 to 2B8	13, 14, 16, 17, 19, 20, 22, 23	F1, F2, G1, G2, H1, H2, J1, J2	A6, B5, B6, A9, D2, D6, A12, B8	data input or output
GND ^[1]	4, 10, 15, 21, 28, 34, 39, 45	B3, D3, G3, J3, J4, G4, D4, B4	A32, A3, A8, A11, A16, A19, A24, A27	ground (0 V)
V _{CC(B)}	7, 18	C3, H3	A1, A10	supply voltage B (nBn inputs are referenced to V _{CC(B)})
$\overline{1OE}, \overline{2OE}$	48, 25	A6, K6	A29, A14	output enable input (active LOW)
1A1 to 1A8	47, 46, 44, 43, 41, 40, 38, 37	B5, B6, C5, C6, D5, D6, E5, E6	B18, A28, D8, D4, A25, B16, B15, A22	data input or output
2A1 to 2A8	36, 35, 33, 32, 30, 29, 27, 26	F6, F5, G6, G5, H6, H5, J6, J5	A21, B13, B12, A18, D3, D7, A15, B10	data input or output
V _{CC(A)}	31, 42	C4, H4	A17, A26	supply voltage A (nAn, \overline{nOE} and nDIR inputs are referenced to V _{CC(A)})
n.c.	-	A2, A3, A4, A5, K2, K3, K4, K5	A4, A7, A20, A23, B1, B4, B7, B9, B11, B14, B17, B19	not connected

[1] All GND pins must be connected to ground (0 V).

6. Functional description

Table 3. Function table^[1]

Supply voltage	Input		Input/output ^[3]	
	\overline{nOE} ^[2]	nDIR ^[2]	nAn ^[2]	nBn ^[2]
0.8 V to 3.6 V	L	L	nAn = nBn	input
0.8 V to 3.6 V	L	H	input	nBn = nAn
0.8 V to 3.6 V	H	X	Z	Z
GND ^[3]	X	X	Z	Z

[1] H = HIGH voltage level; L = LOW voltage level; X = don't care; Z = high-impedance OFF-state.

[2] The nAn, nDIR and \overline{nOE} input circuit is referenced to V_{CC(A)}; The nBn input circuit is referenced to V_{CC(B)}.

[3] If at least one of V_{CC(A)} or V_{CC(B)} is at GND level, the device goes into suspend mode.

7. Limiting values

Table 4. Limiting values

In accordance with the Absolute Maximum Rating System (IEC 60134). Voltages are referenced to GND (ground = 0 V).

Symbol	Parameter	Conditions	Min	Max	Unit
$V_{CC(A)}$	supply voltage A		-0.5	+4.6	V
$V_{CC(B)}$	supply voltage B		-0.5	+4.6	V
I_{IK}	input clamping current	$V_I < 0$ V	-50	-	mA
V_I	input voltage		[1] -0.5	+4.6	V
I_{OK}	output clamping current	$V_O < 0$ V	-50	-	mA
V_O	output voltage	Active mode	[1][2][3] -0.5	$V_{CCO} + 0.5$	V
		Suspend or 3-state mode	[1] -0.5	+4.6	V
I_O	output current	$V_O = 0$ V to V_{CC}	[2] -	± 50	mA
I_{CC}	supply current	$I_{CC(A)}$ or $I_{CC(B)}$	-	100	mA
I_{GND}	ground current		-100	-	mA
T_{stg}	storage temperature		-65	+150	°C
P_{tot}	total power dissipation	$T_{amb} = -40$ °C to $+125$ °C;			
		TSSOP48 package	[4] -	500	mW
		VFBGA56 package	[5] -	1000	mW
		HXQFN60U package	[5] -	1000	mW

- [1] The minimum input voltage ratings and output voltage ratings may be exceeded if the input and output current ratings are observed.
 [2] V_{CCO} is the supply voltage associated with the output port.
 [3] $V_{CCO} + 0.5$ V should not exceed 4.6 V.
 [4] Above 60 °C the value of P_{tot} derates linearly with 5.5 mW/K.
 [5] Above 70 °C the value of P_{tot} derates linearly with 1.8 mW/K.

8. Recommended operating conditions

Table 5. Recommended operating conditions

Symbol	Parameter	Conditions	Min	Max	Unit
$V_{CC(A)}$	supply voltage A		0.8	3.6	V
$V_{CC(B)}$	supply voltage B		0.8	3.6	V
V_I	input voltage		0	3.6	V
V_O	output voltage	Active mode	[1] 0	V_{CCO}	V
		Suspend or 3-state mode	0	3.6	V
T_{amb}	ambient temperature		-40	+125	°C
$\Delta t/\Delta V$	input transition rise and fall rate	$V_{CCI} = 0.8$ V to 3.6 V	[2] -	5	ns/V

- [1] V_{CCO} is the supply voltage associated with the output port.
 [2] V_{CCI} is the supply voltage associated with the input port.

9. Static characteristics

Table 6. Typical static characteristics at $T_{amb} = 25\text{ }^{\circ}\text{C}$

At recommended operating conditions; voltages are referenced to GND (ground = 0 V).

Symbol	Parameter	Conditions	Min	Typ	Max	Unit
V_{OH}	HIGH-level output voltage	$V_I = V_{IH}$ or V_{IL} $I_O = -1.5\text{ mA}$; $V_{CC(A)} = V_{CC(B)} = 0.8\text{ V}$	-	0.69	-	V
V_{OL}	LOW-level output voltage	$V_I = V_{IH}$ or V_{IL} $I_O = 1.5\text{ mA}$; $V_{CC(A)} = V_{CC(B)} = 0.8\text{ V}$	-	0.07	-	V
I_I	input leakage current	nDIR, \overline{nOE} input; $V_I = 0\text{ V}$ or 3.6 V ; $V_{CC(A)} = V_{CC(B)} = 0.8\text{ V}$ to 3.6 V	-	± 0.025	± 0.25	μA
I_{BHL}	bus hold LOW current	A or B port; $V_I = 0.42\text{ V}$; $V_{CC(A)} = V_{CC(B)} = 1.2\text{ V}$	[3]	26	-	μA
I_{BHH}	bus hold HIGH current	A or B port; $V_I = 0.78\text{ V}$; $V_{CC(A)} = V_{CC(B)} = 1.2\text{ V}$	[4]	-24	-	μA
I_{BHLO}	bus hold LOW overdrive current	A or B port; $V_{CC(A)} = V_{CC(B)} = 1.2\text{ V}$	[5]	27	-	μA
I_{BHHO}	bus hold HIGH overdrive current	A or B port; $V_{CC(A)} = V_{CC(B)} = 1.2\text{ V}$	[6]	-26	-	μA
I_{OZ}	OFF-state output current	A or B port; $V_O = 0\text{ V}$ or V_{CCO} ; $V_{CC(A)} = V_{CC(B)} = 3.6\text{ V}$	[7]	± 0.5	± 2.5	μA
		suspend mode A port; $V_O = 0\text{ V}$ or V_{CCO} ; $V_{CC(A)} = 3.6\text{ V}$; $V_{CC(B)} = 0\text{ V}$	[7]	± 0.5	± 2.5	μA
		suspend mode B port; $V_O = 0\text{ V}$ or V_{CCO} ; $V_{CC(A)} = 0\text{ V}$; $V_{CC(B)} = 3.6\text{ V}$	[7]	± 0.5	± 2.5	μA
I_{OFF}	power-off leakage current	A port; V_I or $V_O = 0\text{ V}$ to 3.6 V ; $V_{CC(A)} = 0\text{ V}$; $V_{CC(B)} = 0.8\text{ V}$ to 3.6 V	-	± 0.1	± 1	μA
		B port; V_I or $V_O = 0\text{ V}$ to 3.6 V ; $V_{CC(B)} = 0\text{ V}$; $V_{CC(A)} = 0.8\text{ V}$ to 3.6 V	-	± 0.1	± 1	μA
C_I	input capacitance	nDIR, \overline{nOE} input; $V_I = 0\text{ V}$ or 3.3 V ; $V_{CC(A)} = V_{CC(B)} = 3.3\text{ V}$	-	2.0	-	pF
$C_{I/O}$	input/output capacitance	A and B port; $V_O = 3.3\text{ V}$ or 0 V ; $V_{CC(A)} = V_{CC(B)} = 3.3\text{ V}$	-	4.5	-	pF

[1] V_{CCO} is the supply voltage associated with the output port.

[2] V_{CCI} is the supply voltage associated with the data input port.

[3] The bus hold circuit can sink at least the minimum low sustaining current at V_{IL} max. I_{BHL} should be measured after lowering V_I to GND and then raising it to V_{IL} max.

[4] The bus hold circuit can source at least the minimum high sustaining current at V_{IH} min. I_{BHH} should be measured after raising V_I to V_{CC} and then lowering it to V_{IH} min.

[5] An external driver must source at least I_{BHLO} to switch this node from LOW to HIGH.

[6] An external driver must sink at least I_{BHHO} to switch this node from HIGH to LOW.

[7] For I/O ports, the parameter I_{OZ} includes the input leakage current.

Table 7. Static characteristics [1][2]

At recommended operating conditions; voltages are referenced to GND (ground = 0 V).

Symbol	Parameter	Conditions	-40 °C to +85 °C		-40 °C to +125 °C		Unit
			Min	Max	Min	Max	
V _{IH}	HIGH-level input voltage	data input					
		V _{CCI} = 0.8 V	0.70V _{CCI}	-	0.70V _{CCI}	-	V
		V _{CCI} = 1.1 V to 1.95 V	0.65V _{CCI}	-	0.65V _{CCI}	-	V
		V _{CCI} = 2.3 V to 2.7 V	1.6	-	1.6	-	V
		V _{CCI} = 3.0 V to 3.6 V	2	-	2	-	V
		nDIR, n $\overline{\text{OE}}$ input					
		V _{CC(A)} = 0.8 V	0.70V _{CC(A)}	-	0.70V _{CC(A)}	-	V
		V _{CC(A)} = 1.1 V to 1.95 V	0.65V _{CC(A)}	-	0.65V _{CC(A)}	-	V
		V _{CC(A)} = 2.3 V to 2.7 V	1.6	-	1.6	-	V
		V _{CC(A)} = 3.0 V to 3.6 V	2	-	2	-	V
V _{IL}	LOW-level input voltage	data input					
		V _{CCI} = 0.8 V	-	0.30V _{CCI}	-	0.30V _{CCI}	V
		V _{CCI} = 1.1 V to 1.95 V	-	0.35V _{CCI}	-	0.35V _{CCI}	V
		V _{CCI} = 2.3 V to 2.7 V	-	0.7	-	0.7	V
		V _{CCI} = 3.0 V to 3.6 V	-	0.8	-	0.8	V
		nDIR, n $\overline{\text{OE}}$ input					
		V _{CC(A)} = 0.8 V	-	0.30V _{CC(A)}	-	0.30V _{CC(A)}	V
		V _{CC(A)} = 1.1 V to 1.95 V	-	0.35V _{CC(A)}	-	0.35V _{CC(A)}	V
		V _{CC(A)} = 2.3 V to 2.7 V	-	0.7	-	0.7	V
		V _{CC(A)} = 3.0 V to 3.6 V	-	0.8	-	0.8	V
V _{OH}	HIGH-level output voltage	V _I = V _{IH} or V _{IL}					
		I _O = -100 μ A; V _{CC(A)} = V _{CC(B)} = 0.8 V to 3.6 V	V _{CCO} - 0.1	-	V _{CCO} - 0.1	-	V
		I _O = -3 mA; V _{CC(A)} = V _{CC(B)} = 1.1 V	0.85	-	0.85	-	V
		I _O = -6 mA; V _{CC(A)} = V _{CC(B)} = 1.4 V	1.05	-	1.05	-	V
		I _O = -8 mA; V _{CC(A)} = V _{CC(B)} = 1.65 V	1.2	-	1.2	-	V
		I _O = -9 mA; V _{CC(A)} = V _{CC(B)} = 2.3 V	1.75	-	1.75	-	V
		I _O = -12 mA; V _{CC(A)} = V _{CC(B)} = 3.0 V	2.3	-	2.3	-	V
V _{OL}	LOW-level output voltage	V _I = V _{IH} or V _{IL}					
		I _O = 100 μ A; V _{CC(A)} = V _{CC(B)} = 0.8 V to 3.6 V	-	0.1	-	0.1	V
		I _O = 3 mA; V _{CC(A)} = V _{CC(B)} = 1.1 V	-	0.25	-	0.25	V
		I _O = 6 mA; V _{CC(A)} = V _{CC(B)} = 1.4 V	-	0.35	-	0.35	V
		I _O = 8 mA; V _{CC(A)} = V _{CC(B)} = 1.65 V	-	0.45	-	0.45	V
		I _O = 9 mA; V _{CC(A)} = V _{CC(B)} = 2.3 V	-	0.55	-	0.55	V
		I _O = 12 mA; V _{CC(A)} = V _{CC(B)} = 3.0 V	-	0.7	-	0.7	V
I _I	input leakage current	nDIR, n $\overline{\text{OE}}$ input; V _I = 0 V or 3.6 V; V _{CC(A)} = V _{CC(B)} = 0.8 V to 3.6 V	-	± 1	-	± 5	μ A

Table 7. Static characteristics ...continued [1][2]

At recommended operating conditions; voltages are referenced to GND (ground = 0 V).

Symbol	Parameter	Conditions	-40 °C to +85 °C		-40 °C to +125 °C		Unit
			Min	Max	Min	Max	
I _{BHL}	bus hold LOW current	A or B port [3]					
		V _I = 0.49 V; V _{CC(A)} = V _{CC(B)} = 1.4 V	15	-	15	-	μA
		V _I = 0.58 V; V _{CC(A)} = V _{CC(B)} = 1.65 V	25	-	25	-	μA
		V _I = 0.70 V; V _{CC(A)} = V _{CC(B)} = 2.3 V	45	-	45	-	μA
		V _I = 0.80 V; V _{CC(A)} = V _{CC(B)} = 3.0 V	100	-	90	-	μA
I _{BHH}	bus hold HIGH current	A or B port [4]					
		V _I = 0.91 V; V _{CC(A)} = V _{CC(B)} = 1.4 V	-15	-	-15	-	μA
		V _I = 1.07 V; V _{CC(A)} = V _{CC(B)} = 1.65 V	-25	-	-25	-	μA
		V _I = 1.60 V; V _{CC(A)} = V _{CC(B)} = 2.3 V	-45	-	-45	-	μA
		V _I = 2.00 V; V _{CC(A)} = V _{CC(B)} = 3.0 V	-100	-	-100	-	μA
I _{BHLO}	bus hold LOW overdrive current	A or B port [5]					
		V _{CC(A)} = V _{CC(B)} = 1.6 V	125	-	125	-	μA
		V _{CC(A)} = V _{CC(B)} = 1.95 V	200	-	200	-	μA
		V _{CC(A)} = V _{CC(B)} = 2.7 V	300	-	300	-	μA
		V _{CC(A)} = V _{CC(B)} = 3.6 V	500	-	500	-	μA
I _{BHHO}	bus hold HIGH overdrive current	A or B port [6]					
		V _{CC(A)} = V _{CC(B)} = 1.6 V	-125	-	-125	-	μA
		V _{CC(A)} = V _{CC(B)} = 1.95 V	-200	-	-200	-	μA
		V _{CC(A)} = V _{CC(B)} = 2.7 V	-300	-	-300	-	μA
		V _{CC(A)} = V _{CC(B)} = 3.6 V	-500	-	-500	-	μA
I _{OZ}	OFF-state output current	A or B port; V _O = 0 V or V _{CCO} ; V _{CC(A)} = V _{CC(B)} = 3.6 V [7]	-	±5	-	±30	μA
		suspend mode A port; V _O = 0 V or V _{CCO} ; V _{CC(A)} = 3.6 V; V _{CC(B)} = 0 V [7]	-	±5	-	±30	μA
		suspend mode B port; V _O = 0 V or V _{CCO} ; V _{CC(A)} = 0 V; V _{CC(B)} = 3.6 V [7]	-	±5	-	±30	μA
I _{OFF}	power-off leakage current	A port; V _I or V _O = 0 V to 3.6 V; V _{CC(A)} = 0 V; V _{CC(B)} = 0.8 V to 3.6 V	-	±5	-	±30	μA
		B port; V _I or V _O = 0 V to 3.6 V; V _{CC(B)} = 0 V; V _{CC(A)} = 0.8 V to 3.6 V	-	±5	-	±30	μA

Table 7. Static characteristics ...continued [1][2]

At recommended operating conditions; voltages are referenced to GND (ground = 0 V).

Symbol	Parameter	Conditions	-40 °C to +85 °C		-40 °C to +125 °C		Unit
			Min	Max	Min	Max	
I _{CC}	supply current	A port; V _I = 0 V or V _{CCI} ; I _O = 0 A					
		V _{CC(A)} = 0.8 V to 3.6 V; V _{CC(B)} = 0.8 V to 3.6 V	-	30	-	125	μA
		V _{CC(A)} = 1.1 V to 3.6 V; V _{CC(B)} = 1.1 V to 3.6 V	-	25	-	100	μA
		V _{CC(A)} = 3.6 V; V _{CC(B)} = 0 V	-	25	-	100	μA
		V _{CC(A)} = 0 V; V _{CC(B)} = 3.6 V	-5	-	-20	-	μA
		B port; V _I = 0 V or V _{CCI} ; I _O = 0 A					
		V _{CC(A)} = 0.8 V to 3.6 V; V _{CC(B)} = 0.8 V to 3.6 V	-	30	-	125	μA
		V _{CC(A)} = 1.1 V to 3.6 V; V _{CC(B)} = 1.1 V to 3.6 V	-	25	-	100	μA
		V _{CC(A)} = 3.6 V; V _{CC(B)} = 0 V	-5	-	-20	-	μA
		V _{CC(A)} = 0 V; V _{CC(B)} = 3.6 V	-	25	-	100	μA
		A plus B port (I _{CC(A)} + I _{CC(B)}); I _O = 0 A; V _I = 0 V or V _{CCI} ; V _{CC(A)} = 0.8 V to 3.6 V; V _{CC(B)} = 0.8 V to 3.6 V	-	55	-	185	μA
		A plus B port (I _{CC(A)} + I _{CC(B)}); I _O = 0 A; V _I = 0 V or V _{CCI} ; V _{CC(A)} = 1.1 V to 3.6 V; V _{CC(B)} = 1.1 V to 3.6 V	-	45	-	150	μA

- [1] V_{CCO} is the supply voltage associated with the output port.
- [2] V_{CCI} is the supply voltage associated with the data input port.
- [3] The bus hold circuit can sink at least the minimum low sustaining current at V_{IL} max. I_{BHL} should be measured after lowering V_I to GND and then raising it to V_{IL} max.
- [4] The bus hold circuit can source at least the minimum high sustaining current at V_{IH} min. I_{BHH} should be measured after raising V_I to V_{CC} and then lowering it to V_{IH} min.
- [5] An external driver must source at least I_{BHLO} to switch this node from LOW to HIGH.
- [6] An external driver must sink at least I_{BHHO} to switch this node from HIGH to LOW.
- [7] For I/O ports, the parameter I_{OZ} includes the input leakage current.

Table 8. Typical total supply current (I_{CC(A)} + I_{CC(B)})

V _{CC(A)}	V _{CC(B)}							Unit
	0 V	0.8 V	1.2 V	1.5 V	1.8 V	2.5 V	3.3 V	
0 V	0	0.1	0.1	0.1	0.1	0.1	0.1	μA
0.8 V	0.1	0.1	0.1	0.1	0.1	0.3	1.6	μA
1.2 V	0.1	0.1	0.1	0.1	0.1	0.1	0.8	μA
1.5 V	0.1	0.1	0.1	0.1	0.1	0.1	0.4	μA
1.8 V	0.1	0.1	0.1	0.1	0.1	0.1	0.2	μA
2.5 V	0.1	0.3	0.1	0.1	0.1	0.1	0.1	μA
3.3 V	0.1	1.6	0.8	0.4	0.2	0.1	0.1	μA

10. Dynamic characteristics

Table 9. Typical power dissipation capacitance at $V_{CC(A)} = V_{CC(B)}$ and $T_{amb} = 25\text{ °C}$ [1][2]

Voltages are referenced to GND (ground = 0 V).

Symbol	Parameter	Conditions	$V_{CC(A)} = V_{CC(B)}$						Unit
			0.8 V	1.2 V	1.5 V	1.8 V	2.5 V	3.3 V	
C_{PD}	power dissipation capacitance	A port: (direction nAn to nBn); output enabled	0.2	0.2	0.2	0.2	0.3	0.4	pF
		A port: (direction nAn to nBn); output disabled	0.2	0.2	0.2	0.2	0.3	0.4	pF
		A port: (direction nBn to nAn); output enabled	9	9.7	9.8	10.3	11.7	13.7	pF
		A port: (direction nBn to nAn); output disabled	0.6	0.6	0.6	0.7	0.7	0.7	pF
		B port: (direction nAn to nBn); output enabled	9	9.7	9.8	10.3	11.7	13.7	pF
		B port: (direction nAn to nBn); output disabled	0.6	0.6	0.6	0.7	0.7	0.7	pF
		B port: (direction nBn to nAn); output enabled	0.2	0.2	0.2	0.2	0.3	0.4	pF
		B port: (direction nBn to nAn); output disabled	0.2	0.2	0.2	0.2	0.3	0.4	pF

[1] C_{PD} is used to determine the dynamic power dissipation (P_D in μW).

$$P_D = C_{PD} \times V_{CC}^2 \times f_i \times N + \Sigma(C_L \times V_{CC}^2 \times f_o) \text{ where:}$$

f_i = input frequency in MHz;

f_o = output frequency in MHz;

C_L = load capacitance in pF;

V_{CC} = supply voltage in V;

N = number of inputs switching;

$\Sigma(C_L \times V_{CC}^2 \times f_o)$ = sum of the outputs.

[2] $f_i = 10\text{ MHz}$; $V_i = \text{GND to } V_{CC}$; $t_r = t_f = 1\text{ ns}$; $C_L = 0\text{ pF}$; $R_L = \infty\ \Omega$.

Table 10. Typical dynamic characteristics at $V_{CC(A)} = 0.8\text{ V}$ and $T_{amb} = 25\text{ °C}$

Voltages are referenced to GND (ground = 0 V); for test circuit see [Figure 8](#); for wave forms see [Figure 6](#) and [Figure 7](#)

Symbol	Parameter	Conditions	$V_{CC(B)}$						Unit
			0.8 V	1.2 V	1.5 V	1.8 V	2.5 V	3.3 V	
t_{pd}	propagation delay	nAn to nBn	14.4	7.0	6.2	6.0	5.9	6.0	ns
		nBn to nAn	14.4	12.4	12.1	11.9	11.8	11.8	ns
t_{dis}	disable time	\overline{nOE} to nAn	16.2	16.2	16.2	16.2	16.2	16.2	ns
		\overline{nOE} to nBn	17.6	10.0	9.0	9.1	8.7	9.3	ns
t_{en}	enable time	\overline{nOE} to nAn	21.9	21.9	21.9	21.9	21.9	21.9	ns
		\overline{nOE} to nBn	22.2	11.1	9.8	9.4	9.4	9.6	ns

[1] t_{pd} is the same as t_{PLH} and t_{PHL} ; t_{dis} is the same as t_{PLZ} and t_{PHZ} ; t_{en} is the same as t_{PZL} and t_{PZH} .

Table 11. Typical dynamic characteristics at $V_{CC(B)} = 0.8\text{ V}$ and $T_{amb} = 25\text{ °C}$

Voltages are referenced to GND (ground = 0 V); for test circuit see [Figure 8](#); for wave forms see [Figure 6](#) and [Figure 7](#)

Symbol	Parameter	Conditions	$V_{CC(A)}$						Unit
			0.8 V	1.2 V	1.5 V	1.8 V	2.5 V	3.3 V	
t_{pd}	propagation delay	nAn to nBn	14.4	12.4	12.1	11.9	11.8	11.8	ns
		nBn to nAn	14.4	7.0	6.2	6.0	5.9	6.0	ns
t_{dis}	disable time	\overline{nOE} to nAn	16.2	5.9	4.4	4.2	3.1	3.5	ns
		\overline{nOE} to nBn	17.6	14.2	13.7	13.6	13.3	13.1	ns
t_{en}	enable time	\overline{nOE} to nAn	21.9	6.4	4.4	3.5	2.6	2.3	ns
		\overline{nOE} to nBn	22.2	17.7	17.2	17.0	16.8	16.7	ns

[1] t_{pd} is the same as t_{PLH} and t_{PHL} ; t_{dis} is the same as t_{PLZ} and t_{PHZ} ; t_{en} is the same as t_{PZL} and t_{PZH} .

Table 12. Dynamic characteristics for temperature range $-40\text{ }^{\circ}\text{C}$ to $+85\text{ }^{\circ}\text{C}$ [1]

Voltages are referenced to GND (ground = 0 V); for test circuit see [Figure 8](#); for wave forms see [Figure 6](#) and [Figure 7](#).

Symbol	Parameter	Conditions	$V_{CC(B)}$										Unit
			$1.2\text{ V} \pm 0.1\text{ V}$		$1.5\text{ V} \pm 0.1\text{ V}$		$1.8\text{ V} \pm 0.15\text{ V}$		$2.5\text{ V} \pm 0.2\text{ V}$		$3.3\text{ V} \pm 0.3\text{ V}$		
			Min	Max	Min	Max	Min	Max	Min	Max	Min	Max	
$V_{CC(A)} = 1.1\text{ V to }1.3\text{ V}$													
t_{pd}	propagation delay	nAn to nBn	0.5	9.2	0.5	6.9	0.5	6.0	0.5	5.1	0.5	4.9	ns
		nBn to nAn	0.5	9.2	0.5	8.7	0.5	8.5	0.5	8.2	0.5	8.0	ns
t_{dis}	disable time	\overline{nOE} to nAn	1.5	11.6	1.5	11.6	1.5	11.6	1.5	11.6	1.5	11.6	ns
		\overline{nOE} to nBn	1.5	12.5	1.5	9.7	1.5	9.5	1.0	8.1	1.0	8.9	ns
t_{en}	enable time	\overline{nOE} to nAn	1.0	14.5	1.0	14.5	1.0	14.5	1.0	14.5	1.0	14.5	ns
		\overline{nOE} to nBn	1.1	14.9	1.1	11.0	1.1	9.6	1.0	8.1	1.0	7.7	ns
$V_{CC(A)} = 1.4\text{ V to }1.6\text{ V}$													
t_{pd}	propagation delay	nAn to nBn	0.5	8.7	0.5	6.2	0.5	5.2	0.5	4.1	0.5	3.7	ns
		nBn to nAn	0.5	6.9	0.5	6.2	0.5	5.9	0.5	5.6	0.5	5.5	ns
t_{dis}	disable time	\overline{nOE} to nAn	1.5	9.1	1.5	9.1	1.5	9.1	1.5	9.1	1.5	9.1	ns
		\overline{nOE} to nBn	1.5	11.4	1.5	8.7	1.5	7.5	1.0	6.5	1.0	6.3	ns
t_{en}	enable time	\overline{nOE} to nAn	1.0	10.1	1.0	10.1	1.0	10.1	1.0	10.1	1.0	10.1	ns
		\overline{nOE} to nBn	1.0	13.5	1.0	10.1	0.5	8.1	0.5	5.9	0.5	5.2	ns
$V_{CC(A)} = 1.65\text{ V to }1.95\text{ V}$													
t_{pd}	propagation delay	nAn to nBn	0.5	8.5	0.5	5.9	0.5	4.8	0.5	3.7	0.5	3.3	ns
		nBn to nAn	0.5	6.0	0.5	5.2	0.5	4.8	0.5	4.5	0.5	4.4	ns
t_{dis}	disable time	\overline{nOE} to nAn	1.5	7.7	1.5	7.7	1.5	7.7	1.5	7.7	1.5	7.7	ns
		\overline{nOE} to nBn	1.5	11.1	1.5	8.4	1.5	7.1	1.0	5.9	1.0	5.7	ns
t_{en}	enable time	\overline{nOE} to nAn	1.0	7.8	1.0	7.8	1.0	7.8	1.0	7.8	1.0	7.8	ns
		\overline{nOE} to nBn	1.0	13.0	1.0	9.2	0.5	7.4	0.5	5.3	0.5	4.5	ns
$V_{CC(A)} = 2.3\text{ V to }2.7\text{ V}$													
t_{pd}	propagation delay	nAn to nBn	0.5	8.2	0.5	5.6	0.5	4.6	0.5	3.3	0.5	2.8	ns
		nBn to nAn	0.5	5.1	0.5	4.1	0.5	3.7	0.5	3.4	0.5	3.2	ns
t_{dis}	disable time	\overline{nOE} to nAn	1.0	6.1	1.0	6.1	1.0	6.1	1.0	6.1	1.0	6.1	ns
		\overline{nOE} to nBn	1.0	10.6	1.0	7.9	1.0	6.6	1.0	6.1	1.0	5.2	ns
t_{en}	enable time	\overline{nOE} to nAn	0.5	5.3	0.5	5.3	0.5	5.3	0.5	5.3	0.5	5.3	ns
		\overline{nOE} to nBn	0.5	12.5	0.5	9.4	0.5	7.3	0.5	5.1	0.5	4.5	ns
$V_{CC(A)} = 3.0\text{ V to }3.6\text{ V}$													
t_{pd}	propagation delay	nAn to nBn	0.5	8.0	0.5	5.5	0.5	4.4	0.5	3.2	0.5	2.7	ns
		nBn to nAn	0.5	4.9	0.5	3.7	0.5	3.3	0.5	2.9	0.5	2.7	ns
t_{dis}	disable time	\overline{nOE} to nAn	0.5	5.0	0.5	5.0	0.5	5.0	0.5	5.0	0.5	5.0	ns
		\overline{nOE} to nBn	1.0	10.3	1.0	7.7	1.0	6.5	1.0	5.2	0.5	5.0	ns
t_{en}	enable time	\overline{nOE} to nAn	0.5	4.3	0.5	4.3	0.5	4.2	0.5	4.1	0.5	4.0	ns
		\overline{nOE} to nBn	0.5	12.4	0.5	9.3	0.5	7.2	0.5	4.9	0.5	4.0	ns

[1] t_{pd} is the same as t_{PLH} and t_{PHL} ; t_{dis} is the same as t_{PLZ} and t_{PHZ} ; t_{en} is the same as t_{PZL} and t_{PZH} .

Table 13. Dynamic characteristics for temperature range -40 °C to +125 °C [1]

Voltages are referenced to GND (ground = 0 V); for test circuit see [Figure 8](#); for wave forms see [Figure 6](#) and [Figure 7](#)

Symbol	Parameter	Conditions	V _{CC(B)}										Unit
			1.2 V ± 0.1 V		1.5 V ± 0.1 V		1.8 V ± 0.15 V		2.5 V ± 0.2 V		3.3 V ± 0.3 V		
			Min	Max	Min	Max	Min	Max	Min	Max	Min	Max	
V_{CC(A)} = 1.1 V to 1.3 V													
t _{pd}	propagation delay	nAn to nBn	0.5	10.2	0.5	7.6	0.5	6.6	0.5	5.7	0.5	5.4	ns
		nBn to nAn	0.5	10.2	0.5	9.6	0.5	9.4	0.5	9.1	0.5	8.8	ns
t _{dis}	disable time	n $\overline{\text{OE}}$ to nAn	1.5	12.8	1.5	12.8	1.5	12.8	1.5	12.8	1.5	12.8	ns
		n $\overline{\text{OE}}$ to nBn	1.5	13.8	1.5	10.7	1.5	10.5	1.0	9.0	1.5	9.8	ns
t _{en}	enable time	n $\overline{\text{OE}}$ to nAn	1.0	16.0	1.0	16.0	1.0	16.0	1.0	16.0	1.0	16.0	ns
		n $\overline{\text{OE}}$ to nBn	1.1	16.4	1.1	12.1	1.1	10.6	1.0	9.0	1.0	8.5	ns
V_{CC(A)} = 1.4 V to 1.6 V													
t _{pd}	propagation delay	nAn to nBn	0.5	9.6	0.5	6.9	0.5	5.8	0.5	4.6	0.5	4.1	ns
		nBn to nAn	0.5	7.6	0.5	6.9	0.5	6.5	0.5	6.2	0.5	6.1	ns
t _{dis}	disable time	n $\overline{\text{OE}}$ to nAn	1.5	10.1	1.5	10.1	1.5	10.1	1.5	10.1	1.5	10.1	ns
		n $\overline{\text{OE}}$ to nBn	1.5	12.6	1.5	9.6	1.5	8.3	1.0	7.2	1.0	7.0	ns
t _{en}	enable time	n $\overline{\text{OE}}$ to nAn	1.0	11.2	1.0	11.2	1.0	11.2	1.0	11.2	1.0	11.2	ns
		n $\overline{\text{OE}}$ to nBn	1.0	14.9	1.0	11.2	0.5	9.0	0.5	6.5	0.5	5.8	ns
V_{CC(A)} = 1.65 V to 1.95 V													
t _{pd}	propagation delay	nAn to nBn	0.5	9.4	0.5	6.5	0.5	5.3	0.5	4.1	0.5	3.7	ns
		nBn to nAn	0.5	6.6	0.5	5.8	0.5	5.3	0.5	5.0	0.5	4.9	ns
t _{dis}	disable time	n $\overline{\text{OE}}$ to nAn	1.5	8.5	1.5	8.5	1.5	8.5	1.5	8.5	1.5	8.5	ns
		n $\overline{\text{OE}}$ to nBn	1.5	12.3	1.5	9.3	1.5	7.9	1.0	6.5	1.0	6.3	ns
t _{en}	enable time	n $\overline{\text{OE}}$ to nAn	1.0	8.6	1.0	8.6	1.0	8.6	1.0	8.6	1.0	8.6	ns
		n $\overline{\text{OE}}$ to nBn	1.0	14.3	1.0	10.2	0.5	8.2	0.5	5.9	0.5	5.0	ns
V_{CC(A)} = 2.3 V to 2.7 V													
t _{pd}	propagation delay	nAn to nBn	0.5	9.1	0.5	6.2	0.5	5.1	0.5	3.7	0.5	3.1	ns
		nBn to nAn	0.5	5.7	0.5	4.6	0.5	4.1	0.5	3.8	0.5	3.6	ns
t _{dis}	disable time	n $\overline{\text{OE}}$ to nAn	1.0	6.8	1.0	6.8	1.0	6.8	1.0	6.8	1.0	6.8	ns
		n $\overline{\text{OE}}$ to nBn	1.0	11.7	1.0	8.7	1.0	7.3	1.0	6.8	1.0	5.8	ns
t _{en}	enable time	n $\overline{\text{OE}}$ to nAn	0.5	5.9	0.5	5.9	0.5	5.9	0.5	5.9	0.5	5.9	ns
		n $\overline{\text{OE}}$ to nBn	0.5	13.8	0.5	10.4	0.5	8.1	0.5	5.7	0.5	5.0	ns
V_{CC(A)} = 3.0 V to 3.6 V													
t _{pd}	propagation delay	nAn to nBn	0.5	8.8	0.5	6.1	0.5	4.9	0.5	3.6	0.5	3.0	ns
		nBn to nAn	0.5	5.4	0.5	4.1	0.5	3.7	0.5	3.2	0.5	3.0	ns
t _{dis}	disable time	n $\overline{\text{OE}}$ to nAn	0.5	5.5	0.5	5.5	0.5	5.5	0.5	5.5	0.5	5.5	ns
		n $\overline{\text{OE}}$ to nBn	1.0	11.4	1.0	8.5	1.0	7.2	1.0	5.8	0.5	5.5	ns
t _{en}	enable time	n $\overline{\text{OE}}$ to nAn	0.5	4.8	0.5	4.8	0.5	4.7	0.5	4.6	0.5	4.4	ns
		n $\overline{\text{OE}}$ to nBn	0.5	13.7	0.5	10.3	0.5	8.0	0.5	5.4	0.5	4.4	ns

[1] t_{pd} is the same as t_{PLH} and t_{PHL}; t_{dis} is the same as t_{PLZ} and t_{PHZ}; t_{en} is the same as t_{PZL} and t_{PZH}.

11. Waveforms

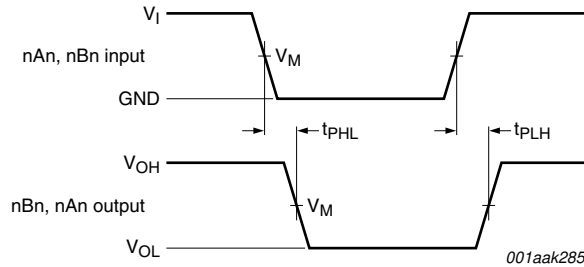

Measurement points are given in [Table 14](#).
 VOL and VOH are typical output voltage levels that occur with the output load.

Fig 6. The data input (nAn, nBn) to output (nBn, nAn) propagation delay times

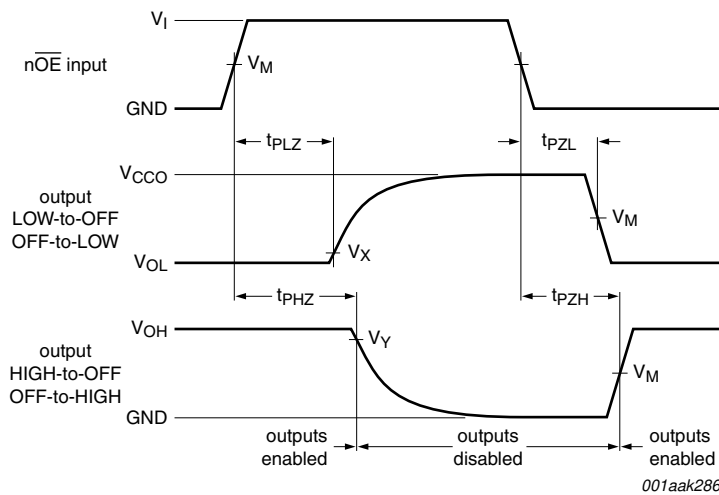

Measurement points are given in [Table 14](#).
 VOL and VOH are typical output voltage levels that occur with the output load.

Fig 7. Enable and disable times

Table 14. Measurement points

Supply voltage	Input ^[1]		Output ^[2]		
	V _{CC(A)} , V _{CC(B)}	V _M	V _M	V _X	V _Y
0.8 V to 1.6 V		0.5V _{CCI}	0.5V _{CCO}	V _{OL} + 0.1 V	V _{OH} - 0.1 V
1.65 V to 2.7 V		0.5V _{CCI}	0.5V _{CCO}	V _{OL} + 0.15 V	V _{OH} - 0.15 V
3.0 V to 3.6 V		0.5V _{CCI}	0.5V _{CCO}	V _{OL} + 0.3 V	V _{OH} - 0.3 V

[1] V_{CCI} is the supply voltage associated with the data input port.

[2] V_{CCO} is the supply voltage associated with the output port.

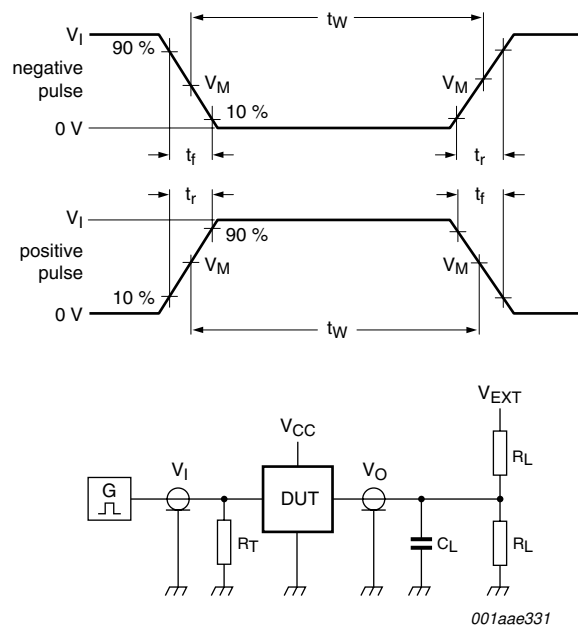

Test data is given in [Table 15](#).

R_L = Load resistance.

C_L = Load capacitance including jig and probe capacitance.

R_T = Termination resistance.

V_{EXT} = External voltage for measuring switching times.

Fig 8. Load circuit for switching times

Table 15. Test data

Supply voltage	Input		Load		V_{EXT}		
$V_{CC(A)}, V_{CC(B)}$	V_I ^[1]	$\Delta t/\Delta V$ ^[2]	C_L	R_L	t_{PLH}, t_{PHL}	t_{PZH}, t_{PHZ}	t_{PZL}, t_{PLZ} ^[3]
0.8 V to 1.6 V	V_{CCI}	≤ 1.0 ns/V	15 pF	2 k Ω	open	GND	$2V_{CCO}$
1.65 V to 2.7 V	V_{CCI}	≤ 1.0 ns/V	15 pF	2 k Ω	open	GND	$2V_{CCO}$
3.0 V to 3.6 V	V_{CCI}	≤ 1.0 ns/V	15 pF	2 k Ω	open	GND	$2V_{CCO}$

[1] V_{CCI} is the supply voltage associated with the data input port.

[2] $dV/dt \geq 1.0$ V/ns

[3] V_{CCO} is the supply voltage associated with the output port.

12. Typical propagation delay characteristics

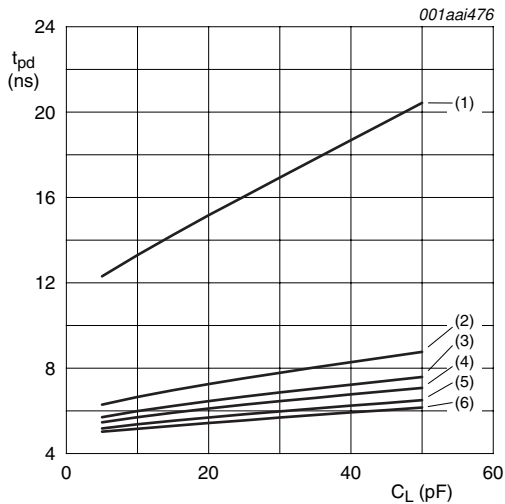

a. Propagation delay (nAn to nBn); $V_{CC(A)} = 0.8\text{ V}$

- (1) $V_{CC(B)} = 0.8\text{ V}$.
- (2) $V_{CC(B)} = 1.2\text{ V}$.
- (3) $V_{CC(B)} = 1.5\text{ V}$.
- (4) $V_{CC(B)} = 1.8\text{ V}$.
- (5) $V_{CC(B)} = 2.5\text{ V}$.
- (6) $V_{CC(B)} = 3.3\text{ V}$.

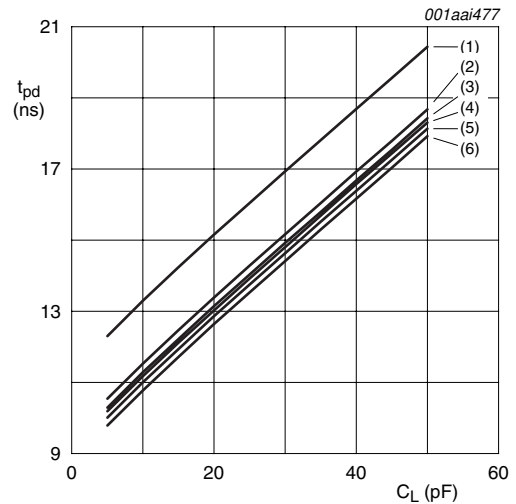

b. Propagation delay (nAn to nBn); $V_{CC(B)} = 0.8\text{ V}$

- (1) $V_{CC(A)} = 0.8\text{ V}$.
- (2) $V_{CC(A)} = 1.2\text{ V}$.
- (3) $V_{CC(A)} = 1.5\text{ V}$.
- (4) $V_{CC(A)} = 1.8\text{ V}$.
- (5) $V_{CC(A)} = 2.5\text{ V}$.
- (6) $V_{CC(A)} = 3.3\text{ V}$.

Fig 9. Typical propagation delay versus load capacitance; $T_{amb} = 25\text{ }^\circ\text{C}$

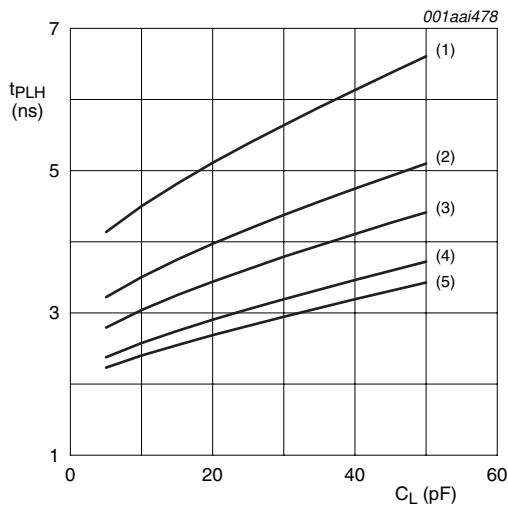

a. LOW to HIGH propagation delay (nAn to nBn);
V_{CC(A)} = 1.2 V

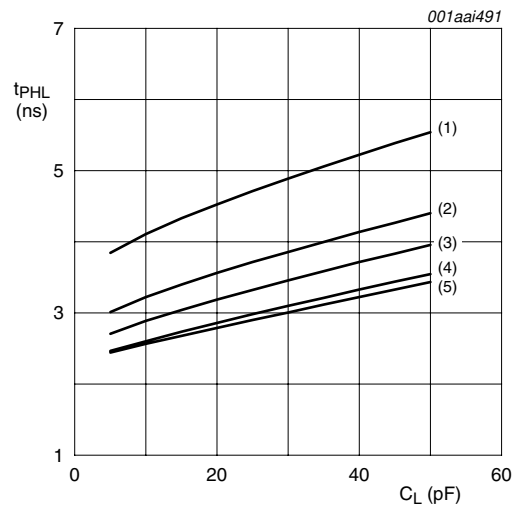

b. HIGH to LOW propagation delay (nAn to nBn);
V_{CC(A)} = 1.2 V

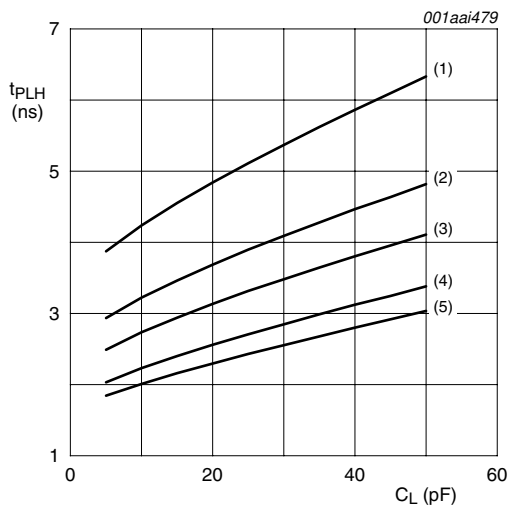

c. LOW to HIGH propagation delay (nAn to nBn);
V_{CC(A)} = 1.5 V

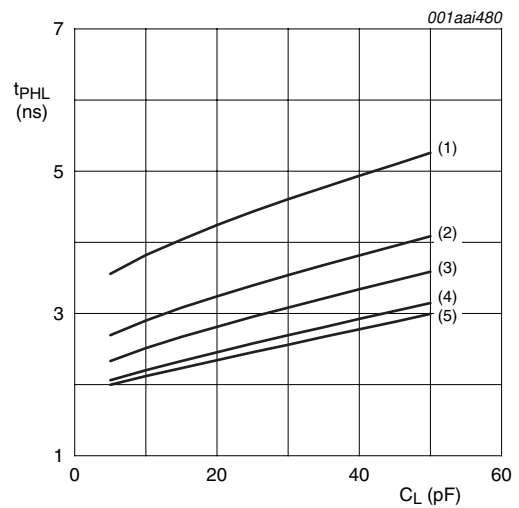

d. HIGH to LOW propagation delay (nAn to nBn);
V_{CC(A)} = 1.5 V

- (1) V_{CC(B)} = 1.2 V.
- (2) V_{CC(B)} = 1.5 V.
- (3) V_{CC(B)} = 1.8 V.
- (4) V_{CC(B)} = 2.5 V.
- (5) V_{CC(B)} = 3.3 V.

Fig 10. Typical propagation delay versus load capacitance; T_{amb} = 25 °C

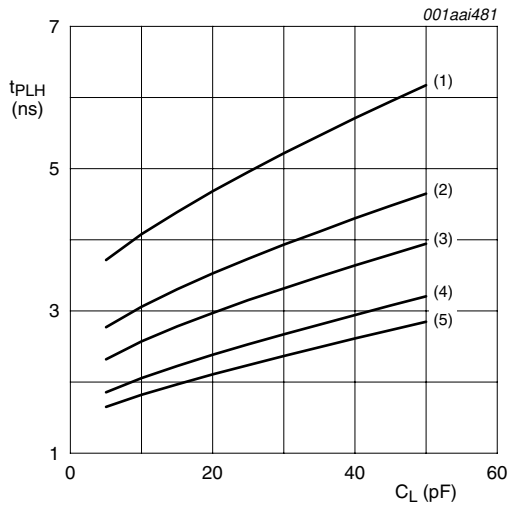

a. LOW to HIGH propagation delay (nAn to nBn);
V_{CC(A)} = 1.8 V

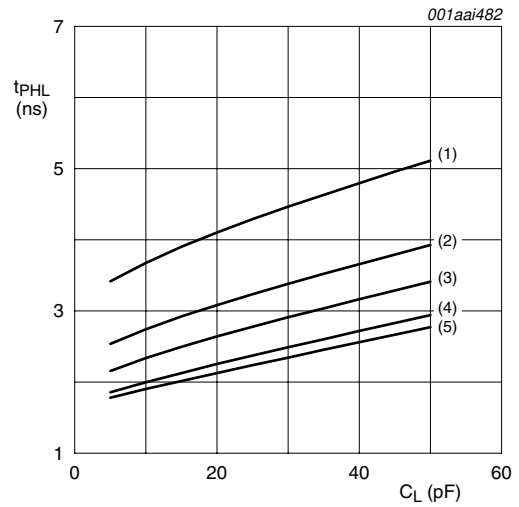

b. HIGH to LOW propagation delay (nAn to nBn);
V_{CC(A)} = 1.8 V

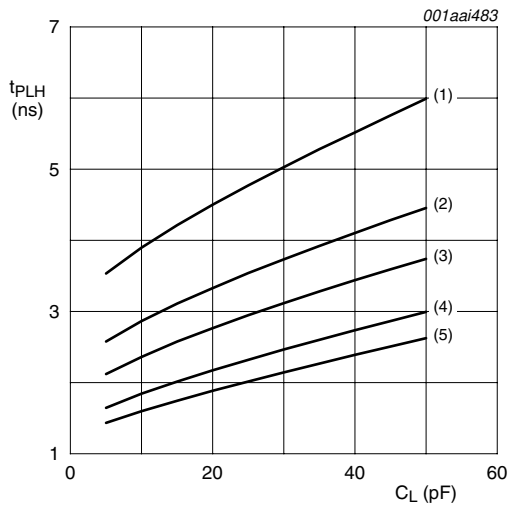

c. LOW to HIGH propagation delay (nAn to nBn);
V_{CC(A)} = 2.5 V

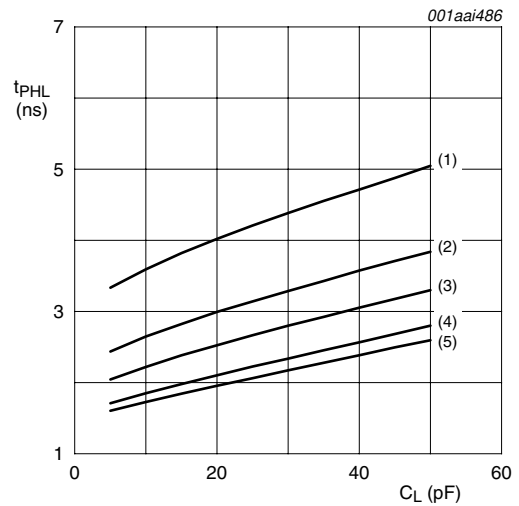

d. HIGH to LOW propagation delay (nAn to nBn);
V_{CC(A)} = 2.5 V

- (1) V_{CC(B)} = 1.2 V.
- (2) V_{CC(B)} = 1.5 V.
- (3) V_{CC(B)} = 1.8 V.
- (4) V_{CC(B)} = 2.5 V.
- (5) V_{CC(B)} = 3.3 V.

Fig 11. Typical propagation delay versus load capacitance; T_{amb} = 25 °C

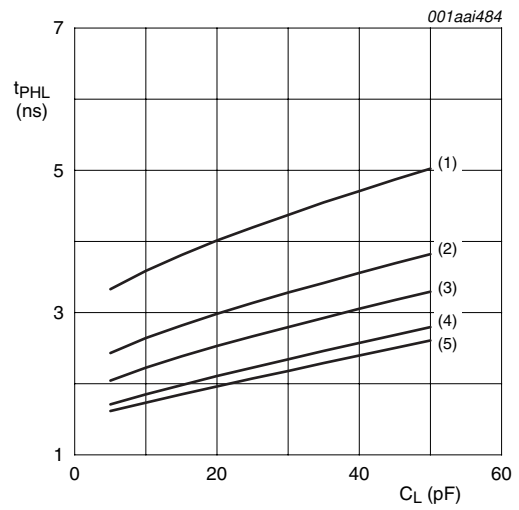
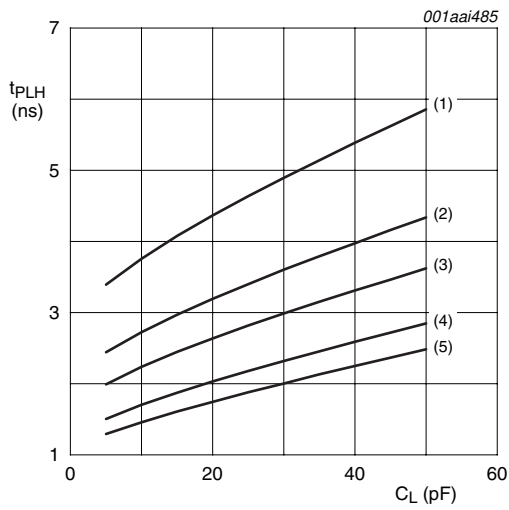

a. LOW to HIGH propagation delay (nAn to nBn);
 $V_{CC(A)} = 3.3\text{ V}$

- (1) $V_{CC(B)} = 1.2\text{ V}$.
- (2) $V_{CC(B)} = 1.5\text{ V}$.
- (3) $V_{CC(B)} = 1.8\text{ V}$.
- (4) $V_{CC(B)} = 2.5\text{ V}$.
- (5) $V_{CC(B)} = 3.3\text{ V}$.

b. HIGH to LOW propagation delay (nAn to nBn);
 $V_{CC(A)} = 3.3\text{ V}$

Fig 12. Typical propagation delay versus load capacitance; $T_{amb} = 25\text{ °C}$

13. Package outline

TSSOP48: plastic thin shrink small outline package; 48 leads; body width 6.1 mm

SOT362-1

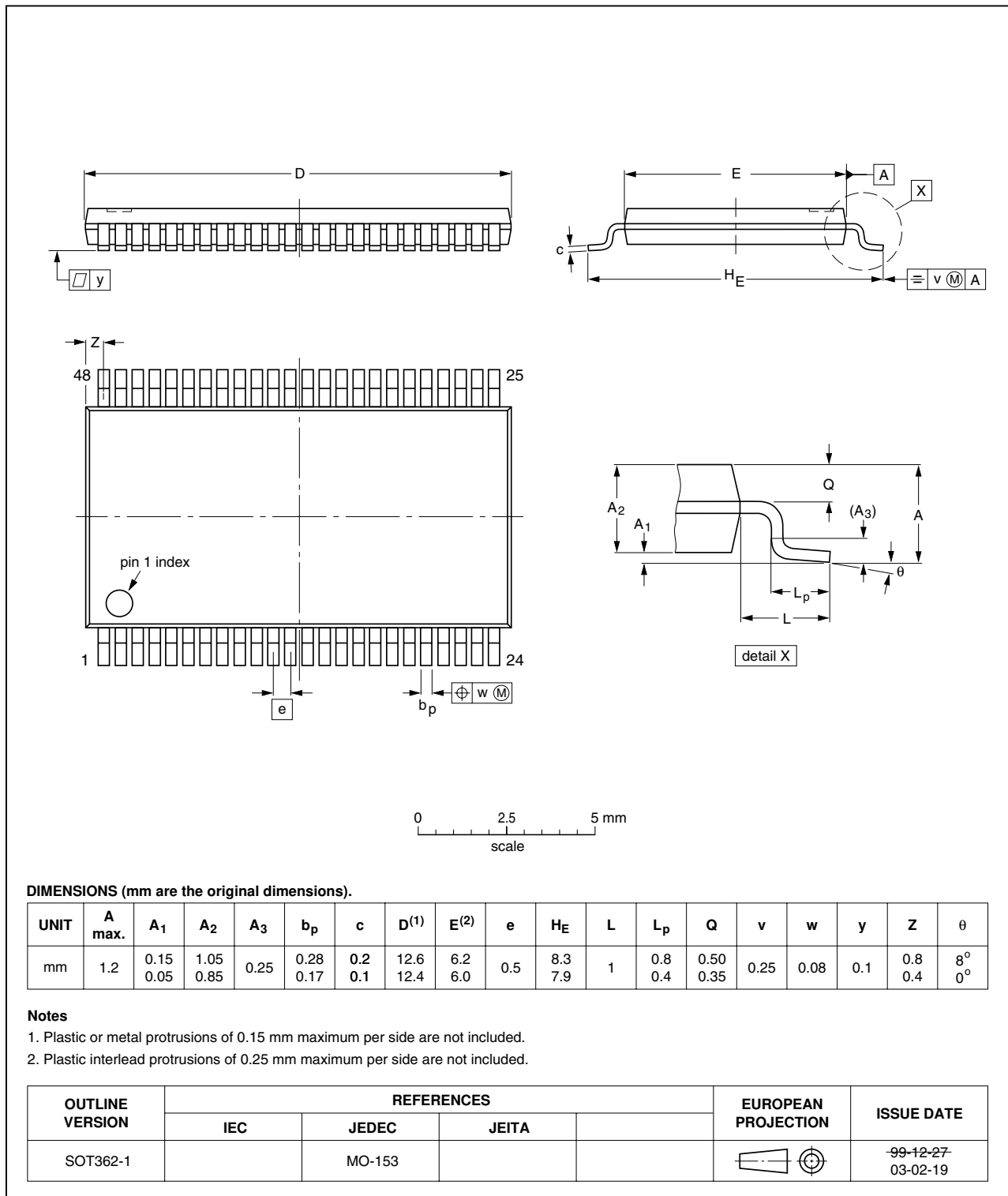

Fig 13. Package outline SOT362-1 (TSSOP48)

TSSOP48: plastic thin shrink small outline package; 48 leads;
body width 4.4 mm; lead pitch 0.4 mm

SOT480-1

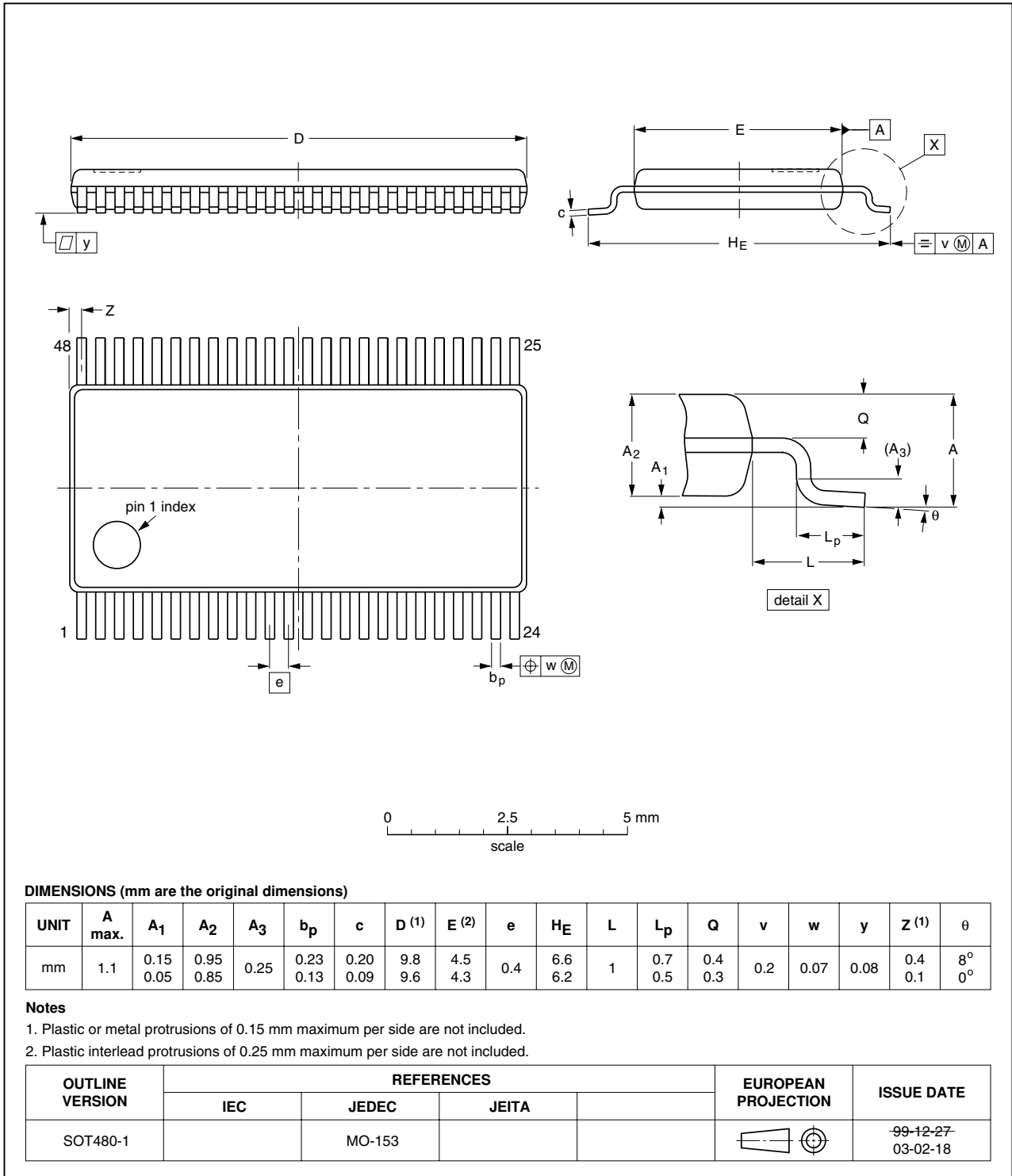

Fig 14. Package outline SOT480-1 (TSSOP48)

VFBGA56: plastic very thin fine-pitch ball grid array package; 56 balls; body 4.5 x 7 x 0.65 mm

SOT702-1

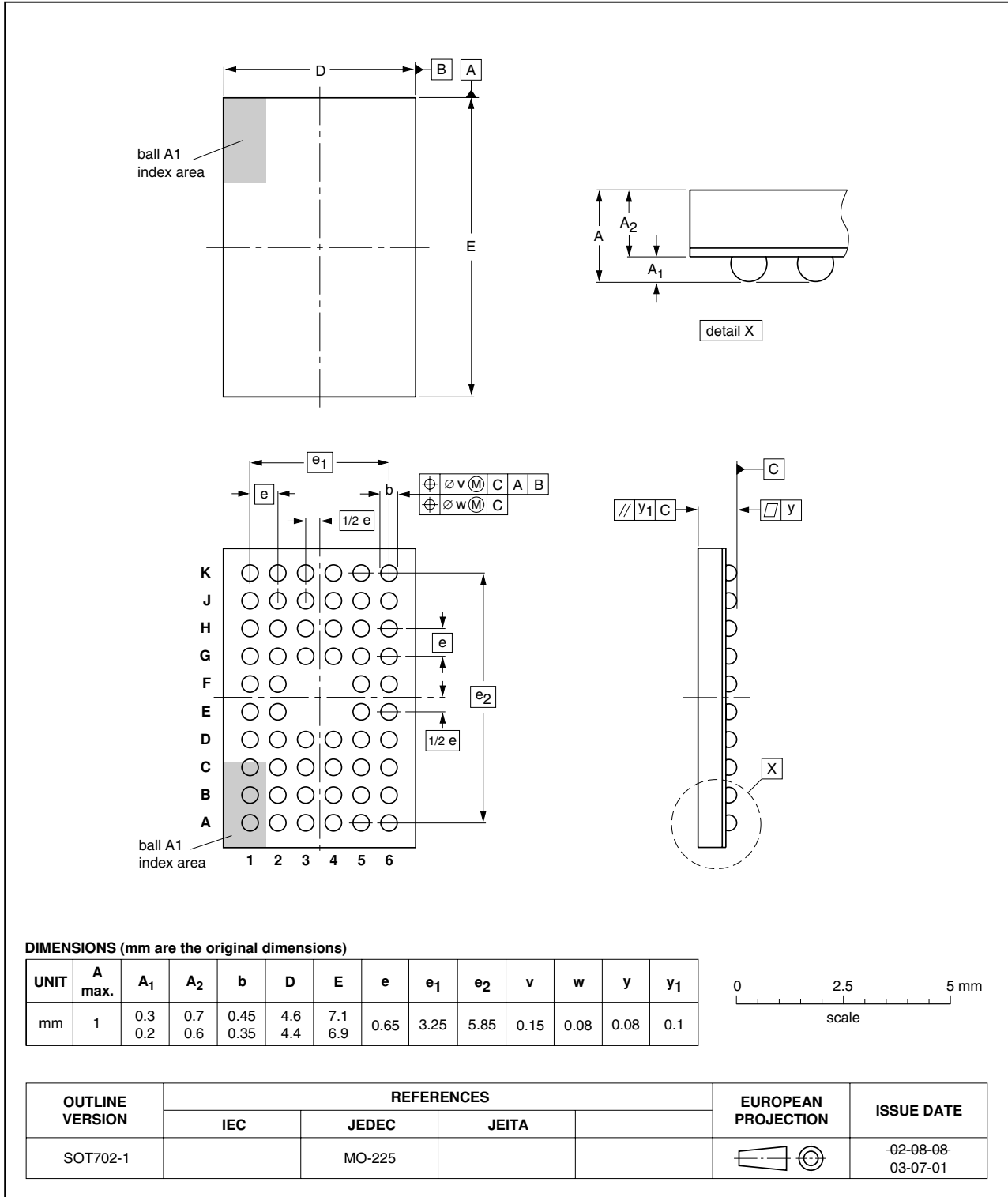

Fig 15. Package outline SOT702-1 (VFBGA56)

HXQFN60U: plastic thermal enhanced extremely thin quad flat package; no leads;
60 terminals; UTLP based; body 4 x 6 x 0.5 mm

SOT1134-1

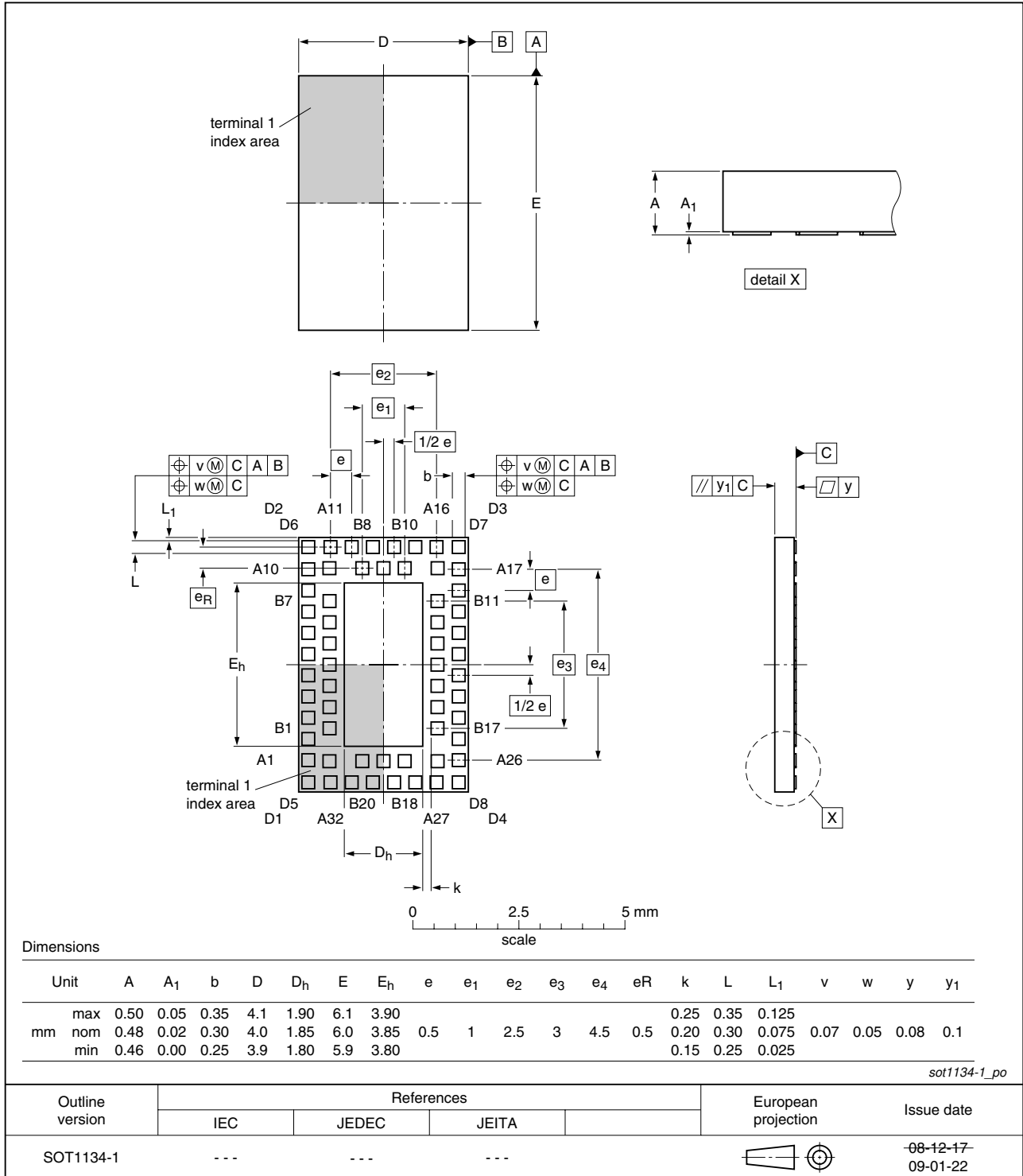

Fig 16. Package outline SOT1134-1 (HXQFN60U)