



Chipsmall Limited consists of a professional team with an average of over 10 year of expertise in the distribution of electronic components. Based in Hongkong, we have already established firm and mutual-benefit business relationships with customers from,Europe,America and south Asia,supplying obsolete and hard-to-find components to meet their specific needs.

With the principle of “Quality Parts,Customers Priority,Honest Operation,and Considerate Service”,our business mainly focus on the distribution of electronic components. Line cards we deal with include Microchip,ALPS,ROHM,Xilinx,Pulse,ON,Everlight and Freescale. Main products comprise IC,Modules,Potentiometer,IC Socket,Relay,Connector.Our parts cover such applications as commercial,industrial, and automotives areas.

We are looking forward to setting up business relationship with you and hope to provide you with the best service and solution. Let us make a better world for our industry!



Contact us

Tel: +86-755-8981 8866 Fax: +86-755-8427 6832

Email & Skype: info@chipsmall.com Web: www.chipsmall.com

Address: A1208, Overseas Decoration Building, #122 Zhenhua RD., Futian, Shenzhen, China



DATA SHEET

74AVCM162835

18-bit registered driver with 15 Ω
termination resistors (3-State)

Product specification

2001 Apr 20

File under Integrated Circuits ICL03

18-bit registered driver with 15 Ω termination resistors (3-State)

74AVCM162835

FEATURES

- Wide supply voltage range of 1.2 V to 3.6 V
- Complies with JEDEC standard no. 8-1A/5/7.
- CMOS low power consumption
- Input/output tolerant up to 3.6 V
- Low inductance multiple V_{CC} and GND pins for minimum noise and ground bounce
- Integrated 15 Ω termination resistors to minimize output overshoot and undershoot
- Full PC133 solution provided when used with PCK2510S and CBT16292

DESCRIPTION

The 74AVCM162835 is a 18-bit universal bus driver. Data flow is controlled by output enable (\overline{OE}), latch enable (LE) and clock inputs (CP).

This product is designed to have an extremely fast propagation delay and a minimum amount of power consumption.

To ensure the high-impedance state during power up or power down, OE should be tied to V_{CC} through a pullup resistor (Live Insertion).

PIN CONFIGURATION

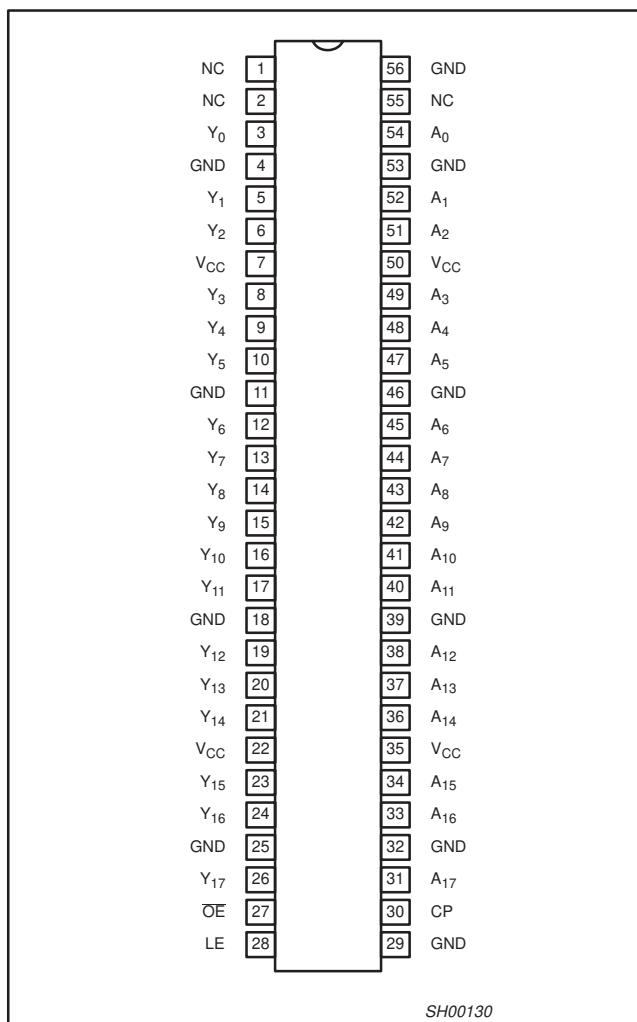

QUICK REFERENCE DATA

GND = 0 V; T_{amb} = 25 °C; t_r = t_f ≤ 2.0 ns; C_L = 30 pF.

SYMBOL	PARAMETER	CONDITIONS	TYPICAL	UNIT	
t _{PHL} /t _{PLH}	Propagation delay An to Yn	V _{CC} = 1.8 V V _{CC} = 2.5 V V _{CC} = 3.3 V	2.6 2.0 1.7	ns	
t _{PHL} /t _{PLH}	Propagation delay LE to Yn; CP to Yn	V _{CC} = 1.8 V V _{CC} = 2.5 V V _{CC} = 3.3 V	2.8 2.2 1.8	ns	
C _I	Input capacitance		5.0	pF	
C _{PD}	Power dissipation capacitance per buffer	V _I = GND to V _{CC} ¹	Outputs enabled Output disabled	25 6	pF

NOTES:

1. C_{PD} is used to determine the dynamic power dissipation (P_D in μW):
 $P_D = C_{PD} \times V_{CC}^2 \times f_i + \sum (C_L \times V_{CC}^2 \times f_o)$ where: f_i = input frequency in MHz; C_L = output load capacitance in pF;
 f_o = output frequency in MHz; V_{CC} = supply voltage in V; $\sum (C_L \times V_{CC}^2 \times f_o)$ = sum of outputs.

ORDERING INFORMATION

PACKAGES	TEMPERATURE RANGE	ORDER CODE	DRAWING NUMBER
56-Pin Plastic Thin Shrink Small Outline (TSSOP) Type II	-40 to +85 °C	74AVCM162835DGG	SOT364-1

18-bit registered driver with 15 Ω termination resistors (3-State)

74AVCM162835

PIN DESCRIPTION

PIN NUMBER	SYMBOL	NAME AND FUNCTION
1, 2, 55	NC	No connection
3, 5, 6, 8, 9, 10, 12, 13, 14, 15, 16, 17, 19, 20, 21, 23, 24, 26	Y ₀ to Y ₁₇	Data outputs
4, 11, 18, 25, 32, 39, 46, 53, 56	GND	Ground (0V)
7, 22, 35, 50	V _{CC}	Positive supply voltage
27	\overline{OE}	Output enable input (active LOW)
28	LE	Latch enable input (active HIGH)
30	CP	Clock input
54, 52, 51, 49, 48, 47, 45, 44, 43, 42, 41, 40, 38, 37, 36, 34, 33, 31	A ₀ to A ₁₇	Data inputs

LOGIC SYMBOL

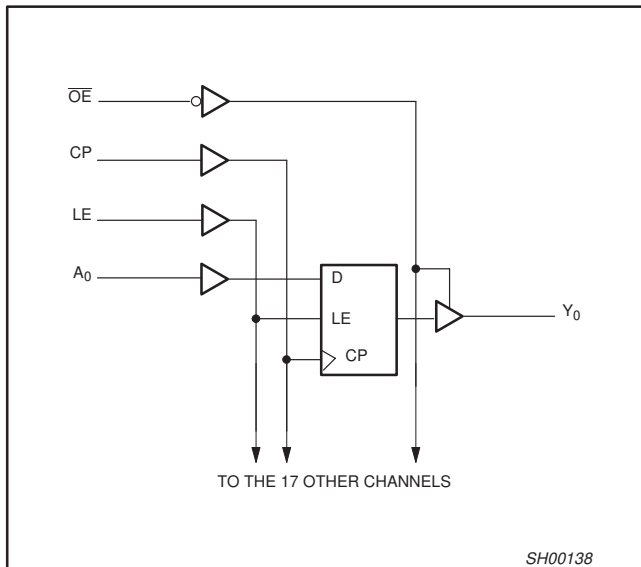

LOGIC SYMBOL (IEEE/IEC)

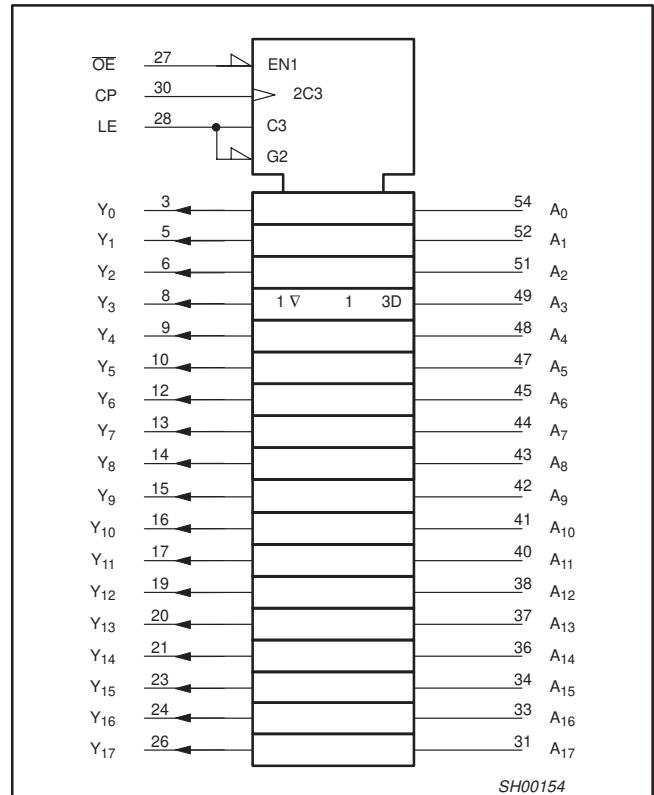

FUNCTION TABLE

INPUTS				OUTPUTS
\overline{OE}	LE	CP	A	
H	X	X	X	Z
L	H	X	L	L
L	H	X	H	H
L	L	↑	L	L
L	L	↑	H	H
L	L	H	X	Y ₀ ¹
L	L	L	X	Y ₀ ²

- H = HIGH voltage level
- L = LOW voltage level
- X = Don't care
- Z = High impedance "off" state
- ↑ = LOW-to-HIGH level transition

NOTES:

1. Output level before the indicated steady-state input conditions were established, provided that CP is high before LE goes low.
2. Output level before the indicated steady-state input conditions were established.

18-bit registered driver with 15 Ω termination resistors (3-State)

74AVCM162835

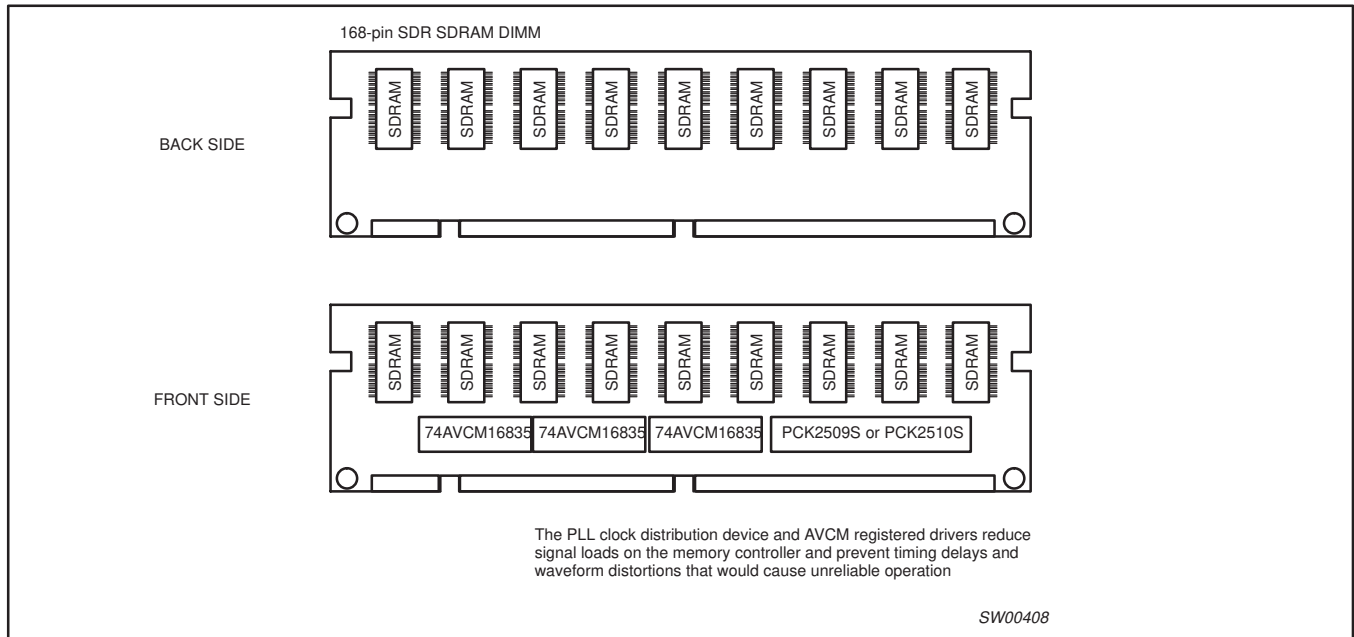

RECOMMENDED OPERATING CONDITIONS

SYMBOL	PARAMETER	CONDITIONS	MIN	MAX	UNIT
V _{CC}	DC supply voltage (according to JEDEC Low Voltage Standards)		1.65 2.3 3.0	1.95 2.7 3.6	V
	DC supply voltage (for low voltage applications)		1.2	3.6	
V _I	DC Input voltage range		0	3.6	V
V _O	DC output voltage range; output 3-State		0	3.6	V
	DC output voltage range; output HIGH or LOW state		0	V _{CC}	
T _{amb}	Operating free-air temperature range		-40	+85	°C
t _r , t _f	Input rise and fall times	V _{CC} = 1.65 to 2.3 V V _{CC} = 2.3 to 3.0 V V _{CC} = 3.0 to 3.6 V	0 0 0	30 20 10	ns/V

18-bit registered driver with 15 Ω termination resistors (3-State)

74AVCM162835

ABSOLUTE MAXIMUM RATINGS

In accordance with the Absolute Maximum Rating System (IEC 134)

Voltages are referenced to GND (ground = 0 V)

SYMBOL	PARAMETER	CONDITIONS	RATING	UNIT
V_{CC}	DC supply voltage		-0.5 to +4.6	V
I_{IK}	DC input diode current	$V_I < 0$	-50	mA
V_I	DC input voltage	For all inputs ¹	-0.5 to 4.6	V
I_{OK}	DC output diode current	$V_O > V_{CC}$ or $V_O < 0$	± 50	mA
V_O	DC output voltage; output 3-State	Note 1	-0.5 to 4.6	V
V_O	DC output voltage; output HIGH or LOW state	Note 1	-0.5 to $V_{CC} + 0.5$	V
I_O	DC output source or sink current	$V_O = 0$ to V_{CC}	± 50	mA
I_{GND}, I_{CC}	DC V_{CC} or GND current		± 100	mA
T_{stg}	Storage temperature range		-65 to +150	$^{\circ}\text{C}$
P_{TOT}	Power dissipation per package -plastic thin-medium-shrink (TSSOP)	For temperature range: -40 to +125 $^{\circ}\text{C}$ above +55 $^{\circ}\text{C}$ derate linearly with 8 mW/K	600	mW

NOTE:

1. The input and output voltage ratings may be exceeded if the input and output current ratings are observed.

DC ELECTRICAL CHARACTERISTICS

Over recommended operating conditions. Voltage are referenced to GND (ground = 0 V).

SYMBOL	PARAMETER	TEST CONDITIONS	LIMITS			UNIT
			Temp = -40 to +85 $^{\circ}\text{C}$			
			MIN	TYP ¹	MAX	
V_{IH}	HIGH level Input voltage	$V_{CC} = 1.2\text{ V}$	V_{CC}	-	-	V
		$V_{CC} = 1.65\text{ to }1.95\text{ V}$	$0.65V_{CC}$	0.9	-	
		$V_{CC} = 2.3\text{ to }2.7\text{ V}$	1.7	1.2	-	
		$V_{CC} = 3.0\text{ to }3.6\text{ V}$	2.0	1.5	-	
V_{IL}	LOW level Input voltage	$V_{CC} = 1.2\text{ V}$	-	-	GND	V
		$V_{CC} = 1.65\text{ to }1.95\text{ V}$	-	0.9	$0.35V_{CC}$	
		$V_{CC} = 2.3\text{ to }2.7\text{ V}$	-	1.2	0.7	
		$V_{CC} = 3.0\text{ to }3.6\text{ V}$	-	1.5	0.8	
V_{OH}	HIGH level output voltage	$V_{CC} = 1.65\text{ to }3.6\text{ V}; V_I = V_{IH}\text{ or }V_{IL}; I_O = -100\ \mu\text{A}$	$V_{CC} - 0.20$	V_{CC}	-	V
		$V_{CC} = 1.65\text{ V}; V_I = V_{IH}\text{ or }V_{IL}; I_O = -4\text{ mA}$	$V_{CC} - 0.45$	$V_{CC} - 0.10$	-	
		$V_{CC} = 2.3\text{ V}; V_I = V_{IH}\text{ or }V_{IL}; I_O = -8\text{ mA}$	$V_{CC} - 0.55$	$V_{CC} - 0.28$	-	
		$V_{CC} = 3.0\text{ V}; V_I = V_{IH}\text{ or }V_{IL}; I_O = -12\text{ mA}$	$V_{CC} - 0.70$	$V_{CC} - 0.32$	-	
V_{OL}	LOW level output voltage	$V_{CC} = 1.65\text{ to }3.6\text{ V}; V_I = V_{IH}\text{ or }V_{IL}; I_O = 100\ \mu\text{A}$	-	GND	0.20	V
		$V_{CC} = 1.65\text{ V}; V_I = V_{IH}\text{ or }V_{IL}; I_O = 4\text{ mA}$	-	0.10	0.45	
		$V_{CC} = 2.3\text{ V}; V_I = V_{IH}\text{ or }V_{IL}; I_O = 8\text{ mA}$	-	0.26	0.55	
		$V_{CC} = 3.0\text{ V}; V_I = V_{IH}\text{ or }V_{IL}; I_O = 12\text{ mA}$	-	0.36	0.70	
I_I	Input leakage current	$V_{CC} = 1.65\text{ to }3.6\text{ V}; V_I = V_{CC}\text{ or GND}$	-	0.1	2.5	μA
I_{OFF}	3-State output OFF-state current	$V_{CC} = 0\text{ V}; V_I\text{ or }V_O = 3.6\text{ V}$	-	0.1	± 10	μA
I_{IHZ}/I_{ILZ}	3-State output OFF-state current	$V_{CC} = 1.65\text{ to }3.6\text{ V}; V_I = V_{CC}\text{ or GND}$	-	0.1	12.5	μA
I_{OZ}	3-State output OFF-state current	$V_{CC} = 1.65\text{ to }2.7\text{ V}; V_I = V_{IH}\text{ or }V_{IL}; V_O = V_{CC}\text{ or GND}$	-	0.1	5	μA
		$V_{CC} = 3.0\text{ to }3.6\text{ V}; V_I = V_{IH}\text{ or }V_{IL}; V_O = V_{CC}\text{ or GND}$	-	0.1	10	
I_{CC}	Quiescent supply current	$V_{CC} = 1.65\text{ to }2.7\text{ V}; V_I = V_{CC}\text{ or GND}; I_O = 0$	-	0.1	20	μA
		$V_{CC} = 3.0\text{ to }3.6\text{ V}; V_I = V_{CC}\text{ or GND}; I_O = 0$	-	0.2	40	

NOTES:

1. All typical values are at $T_{amb} = 25\text{ }^{\circ}\text{C}$.

18-bit registered driver with 15 Ω termination resistors (3-State)

74AVCM162835

AC CHARACTERISTICS

GND = 0 V; $t_r = t_f \leq 2.0$ ns; $C_L = 30$ pF

SYMBOL	PARAMETER	WAVE-FORM	LIMITS										UNIT	
			$V_{CC} = 3.3 \pm 0.3$ V			$V_{CC} = 2.5 \pm 0.2$ V			$V_{CC} = 1.8 \pm 0.15$ V			$V_{CC} = 1.2$ V		
			MIN	TYP ¹	MAX	MIN	TYP ¹	MAX	MIN	TYP ¹	MAX	MIN		TYP
t_{PHL}/t_{PLH}	Propagation delay An to Yn	1, 7	0.7	1.7	2.5	0.8	2.0	3.1	1.0	2.6	4.5	–	5.2	ns
	Propagation delay LE to Yn	2, 7	0.7	1.8	2.7	0.8	2.2	3.3	1.0	2.8	5.0	–	5.6	
	Propagation delay CP to Yn	3, 7	0.7	1.7	2.5	0.8	2.0	3.0	1.0	2.6	4.5	–	5.2	
t_{PZH}/t_{PZL}	3-State output enable time \overline{OE} to Yn	6, 7	1.0	2.3	4.5	1.0	2.5	4.5	1.5	3.0	6.5	–	5.5	ns
t_{PHZ}/t_{PLZ}	3-State output disable time \overline{OE} to Yn	6, 7	1.0	2.3	3.5	1.0	2.2	4.0	1.5	3.5	6.5	–	6.9	ns
t_w	CP pulse width HIGH or LOW	3, 7	1.0	–	–	1.2	–	–	2.0	–	–	–	–	ns
	LE pulse width HIGH	2, 7	1.0	–	–	1.2	–	–	2.0	–	–	–	–	
t_{SU}	Set-up time An to CP	5, 7	0.7	–	–	0.7	–	–	0.7	–	–	1.0	–	ns
	Set-up time An to LE HIGH	4, 7	0.5	–	–	0.5	–	–	0.5	–	–	0.2	–	
	Set-up time An to LE LOW	4, 7	0.5	–	–	0.5	–	–	0.6	–	–	2.0	–	
t_h	Hold time An to CP	5, 7	0.9	–	–	0.9	–	–	1.0	–	–	1.5	–	ns
	Hold time An to LE HIGH	4, 7	1.6	–	–	1.7	–	–	2.0	–	–	3.2	–	
	Hold time An to LE LOW	4, 7	1.4	–	–	1.5	–	–	1.7	–	–	2.8	–	
F_{max}	Maximum clock pulse frequency	3, 7	500	–	–	400	–	–	250	–	–	–	–	MHz

NOTES:

1. All typical values are measured at $T_{amb} = 25$ °C and at $V_{CC} = 1.8$ V, 2.5 V, 3.3 V.

18-bit registered driver with 15 Ω termination resistors (3-State)

74AVCM162835

AC WAVEFORMS FOR $V_{CC} = 3.0\text{ V TO } 3.6\text{ V RANGE}$

$V_M = 0.5 V_{CC}$
 $V_X = V_{OL} + 0.300\text{ V}$
 $V_Y = V_{OH} - 0.300\text{ V}$
 V_{OL} and V_{OH} are the typical output voltage drop that occur with the output load.
 $V_I = V_{CC}$

AC WAVEFORMS FOR $V_{CC} = 2.3\text{ V TO } 2.7\text{ V AND } V_{CC} < 2.3\text{ V RANGE}$

$V_M = 0.5 V_{CC}$
 $V_X = V_{OL} + 0.15\text{ V}$
 $V_Y = V_{OH} - 0.15\text{ V}$
 V_{OL} and V_{OH} are the typical output voltage drop that occur with the output load.
 $V_I = V_{CC}$

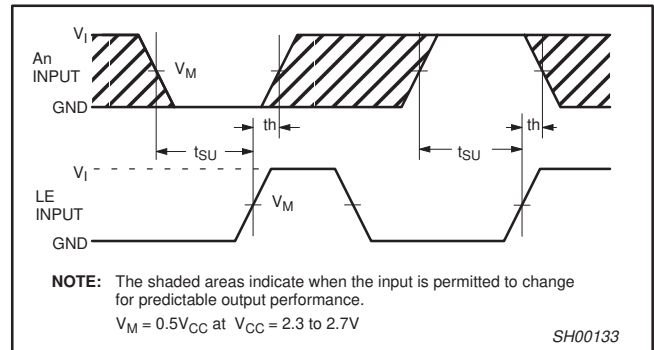

Waveform 4. Data set-up and hold times for the An input to the LE input

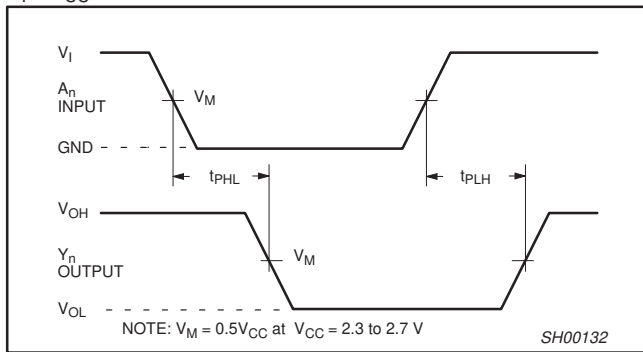

Waveform 1. Input (An) to output (Yn) propagation delay

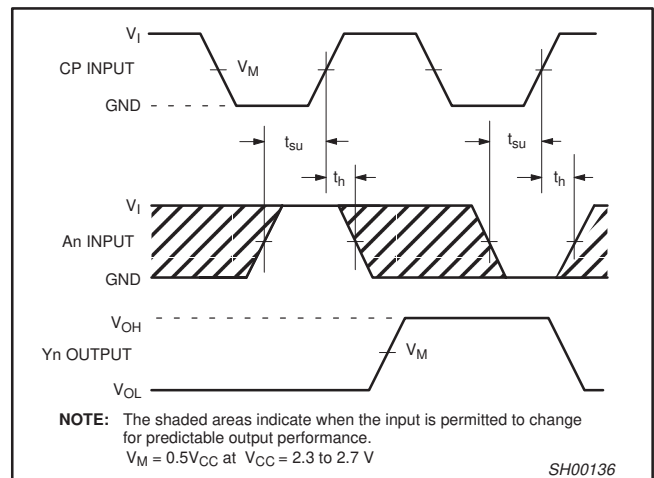

Waveform 5. Data set-up and hold times for the An input to the clock CP input

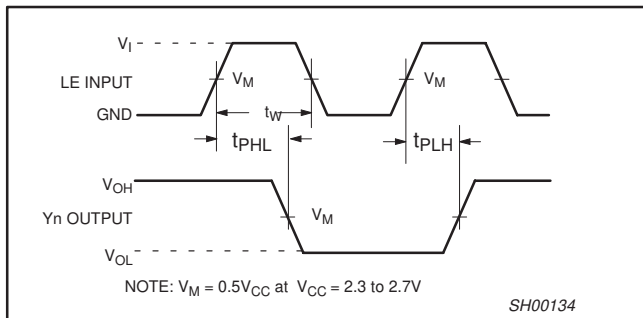

Waveform 2. Latch enable input (LE) pulse width, the latch enable input to output (Yn) propagation delays.

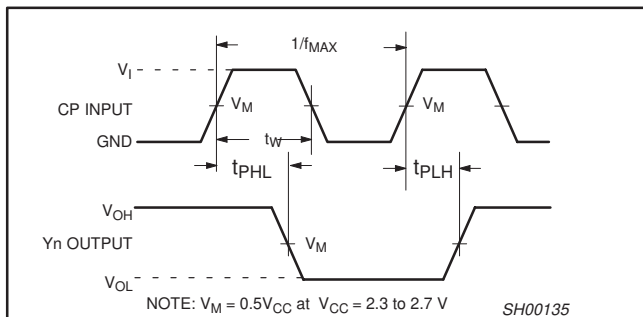

Waveform 3. The clock (CP) to Yn propagation delays, the clock pulse width and the maximum clock frequency.

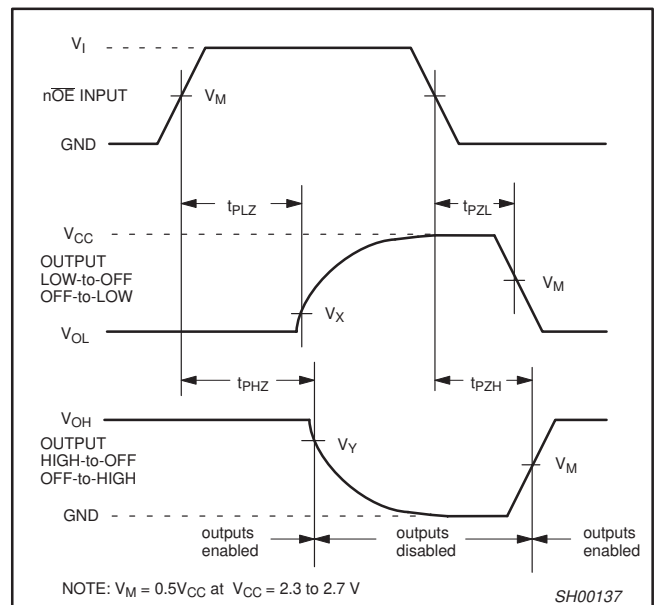

Waveform 6. 3-State enable and disable times

18-bit registered driver with 15 Ω termination resistors (3-State)

74AVCM162835

TEST CIRCUIT

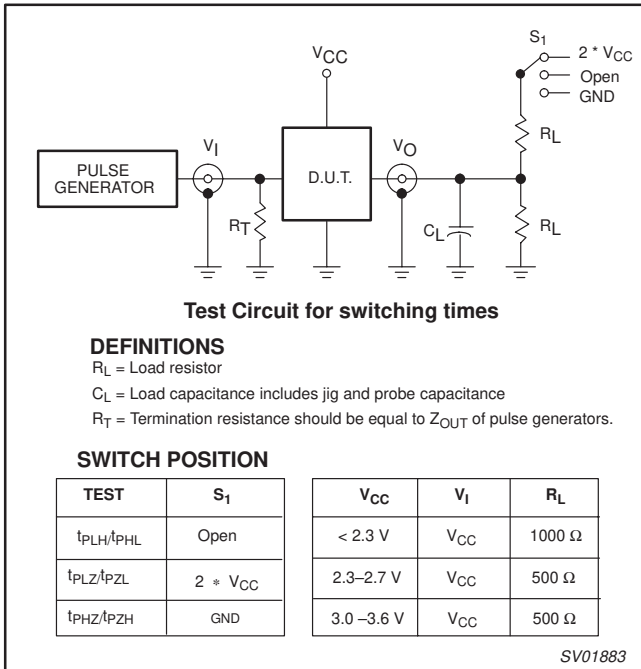

Waveform 7. Load circuitry for switching times

18-bit registered driver with 15 Ω termination resistors (3-State)

74AVCM162835

TSSOP56: plastic thin shrink small outline package; 56 leads; body width 6.1 mm

SOT364-1

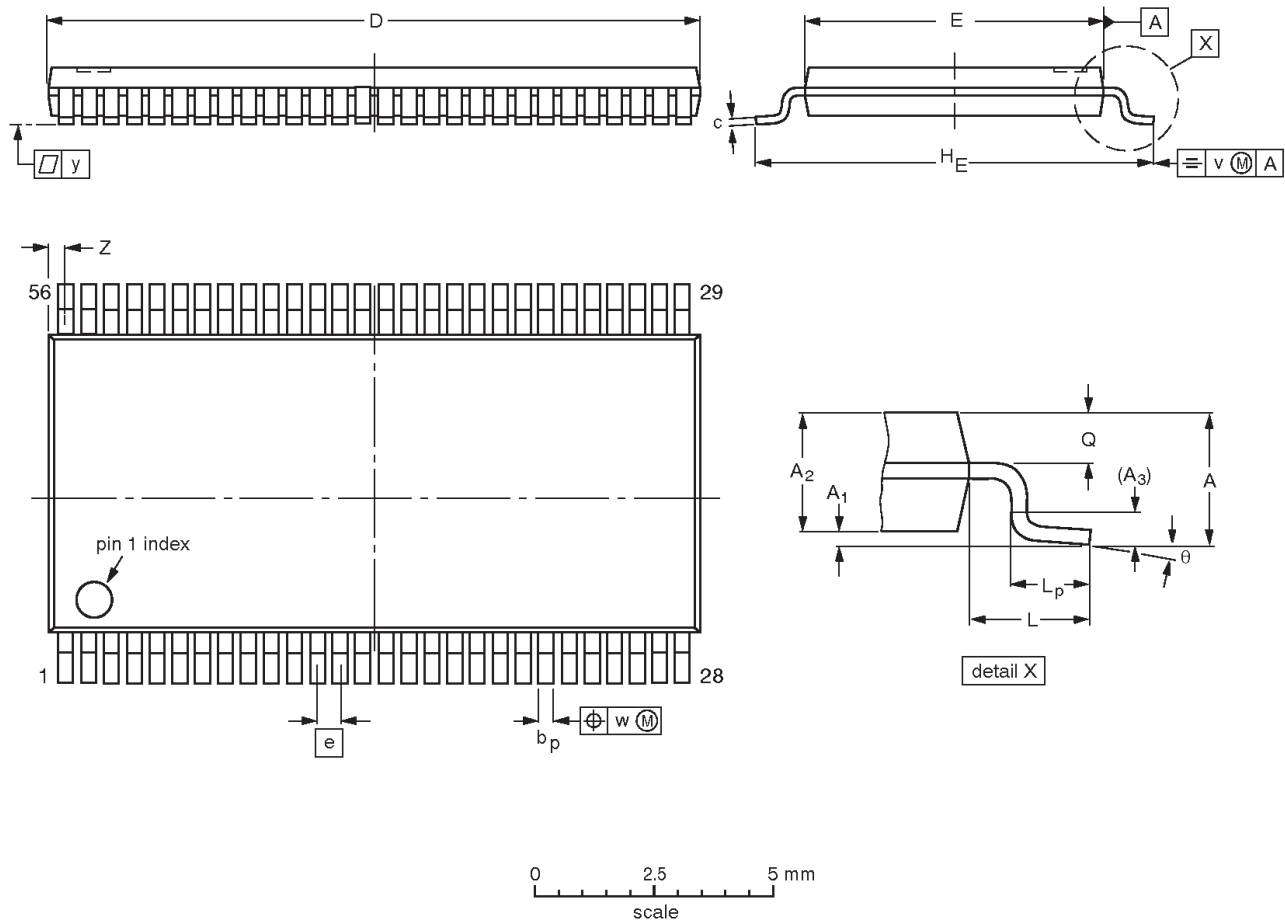

DIMENSIONS (mm are the original dimensions).

UNIT	A max.	A ₁	A ₂	A ₃	b _p	c	D ⁽¹⁾	E ⁽²⁾	e	H _E	L	L _p	Q	v	w	y	Z	θ
mm	1.2	0.15 0.05	1.05 0.85	0.25	0.28 0.17	0.2 0.1	14.1 13.9	6.2 6.0	0.5	8.3 7.9	1.0	0.8 0.4	0.50 0.35	0.25	0.08	0.1	0.5 0.1	8° 0°

Notes

1. Plastic or metal protrusions of 0.15 mm maximum per side are not included.
2. Plastic interlead protrusions of 0.25 mm maximum per side are not included.

OUTLINE VERSION	REFERENCES				EUROPEAN PROJECTION	ISSUE DATE
	IEC	JEDEC	EIAJ			
SOT364-1		MO-153				95-02-10 99-12-27

18-bit registered driver with 15 Ω termination resistors (3-State)

74AVCM162835

Data sheet status

Data sheet status	Product status	Definition [1]
Objective specification	Development	This data sheet contains the design target or goal specifications for product development. Specification may change in any manner without notice.
Preliminary specification	Qualification	This data sheet contains preliminary data, and supplementary data will be published at a later date. Philips Semiconductors reserves the right to make changes at any time without notice in order to improve design and supply the best possible product.
Product specification	Production	This data sheet contains final specifications. Philips Semiconductors reserves the right to make changes at any time without notice in order to improve design and supply the best possible product.

[1] Please consult the most recently issued datasheet before initiating or completing a design.

Definitions

Short-form specification — The data in a short-form specification is extracted from a full data sheet with the same type number and title. For detailed information see the relevant data sheet or data handbook.

Limiting values definition — Limiting values given are in accordance with the Absolute Maximum Rating System (IEC 134). Stress above one or more of the limiting values may cause permanent damage to the device. These are stress ratings only and operation of the device at these or at any other conditions above those given in the Characteristics sections of the specification is not implied. Exposure to limiting values for extended periods may affect device reliability.

Application information — Applications that are described herein for any of these products are for illustrative purposes only. Philips Semiconductors make no representation or warranty that such applications will be suitable for the specified use without further testing or modification.

Disclaimers

Life support — These products are not designed for use in life support appliances, devices or systems where malfunction of these products can reasonably be expected to result in personal injury. Philips Semiconductors customers using or selling these products for use in such applications do so at their own risk and agree to fully indemnify Philips Semiconductors for any damages resulting from such application.

Right to make changes — Philips Semiconductors reserves the right to make changes, without notice, in the products, including circuits, standard cells, and/or software, described or contained herein in order to improve design and/or performance. Philips Semiconductors assumes no responsibility or liability for the use of any of these products, conveys no license or title under any patent, copyright, or mask work right to these products, and makes no representations or warranties that these products are free from patent, copyright, or mask work right infringement, unless otherwise specified.

Philips Semiconductors
811 East Arques Avenue
P.O. Box 3409
Sunnyvale, California 94088-3409
Telephone 800-234-7381

© Copyright Philips Electronics North America Corporation 2001
All rights reserved. Printed in U.S.A.

print code

Date of release: 04-01

Document order number:

9397-750-08283

Let's make things better.