



Chipsmall Limited consists of a professional team with an average of over 10 year of expertise in the distribution of electronic components. Based in Hongkong, we have already established firm and mutual-benefit business relationships with customers from,Europe,America and south Asia,supplying obsolete and hard-to-find components to meet their specific needs.

With the principle of "Quality Parts,Customers Priority,Honest Operation,and Considerate Service",our business mainly focus on the distribution of electronic components. Line cards we deal with include Microchip,ALPS,ROHM,Xilinx,Pulse,ON,Everlight and Freescale. Main products comprise IC,Modules,Potentiometer,IC Socket,Relay,Connector.Our parts cover such applications as commercial,industrial, and automotives areas.

We are looking forward to setting up business relationship with you and hope to provide you with the best service and solution. Let us make a better world for our industry!



Contact us

Tel: +86-755-8981 8866 Fax: +86-755-8427 6832

Email & Skype: info@chipsmall.com Web: www.chipsmall.com

Address: A1208, Overseas Decoration Building, #122 Zhenhua RD., Futian, Shenzhen, China



74F2244

Octal Buffer/Line Driver with 25Ω Series Resistors in Outputs

General Description

The F2244 is an octal buffer/line driver designed to drive the capacitive inputs of MOS memory drivers, address drivers, clock drivers and bus-oriented transmitters/receivers.

The 25Ω series resistors in the outputs reduce ringing and eliminate the need for external resistors.

Features

- 3-STATE outputs drive bus lines or buffer memory address registers
- 12 mA source current
- 25Ω series resistors in outputs eliminate the need for external resistors.
- Designed to drive the capacitive inputs of MOS devices
- Guaranteed 4000V minimum ESD protection

Ordering Code:

| Order Number | Package Number | Package Description |
|--------------|----------------|---|
| 74F2244SC | M20B | 20-Lead Small Outline Integrated Circuit (SOIC), JEDEC MS-013, 0.300 Wide |
| 74F2244MSA | MSA20 | 20-Lead Shrink Small Outline Package (SSOP), EIAJ TYPE II, 5.3mm Wide |
| 74F2244PC | N20A | 20-Lead Plastic Dual-In-Line Package (PDIP), JEDEC MS-001, 0.300 Wide |

Devices also available in Tape and Reel. Specify by appending the suffix letter "X" to the ordering code.

Connection Diagram

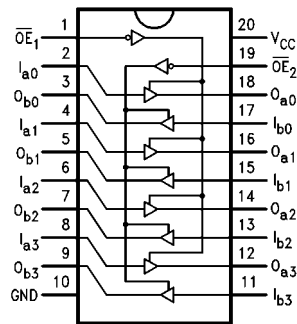

Logic Symbol

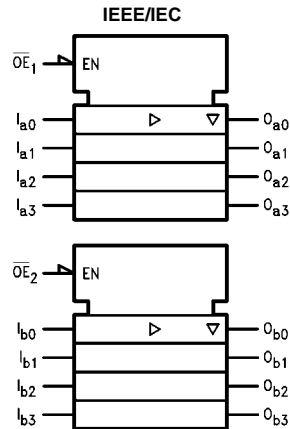

74F2244 Octal Buffer/Line Driver with 25Ω Series Resistors in Outputs

Unit Loading/Fan Out

| Pin Names | Description | U.L. HIGH/LOW | Input I_{IH}/I_{IL} Output I_{OH}/I_{OL} |
|------------------------------------|---|--------------------|---|
| $\overline{OE}_1, \overline{OE}_2$ | 3-STATE Output Enable Input (Active LOW) | 1.0/1.667 | 20 μ A/-1 mA |
| OE_2 | 3-STATE Output Enable Input (Active HIGH) | 1.0/1.667 | 20 μ A/-1 mA |
| I_{an}, I_{bn} | Inputs | 1.0/2.667 (Note 1) | 20 μ A/-1.6 mA |
| O_{an}, O_{bn} | Outputs | 750/20 | -15 mA/12 mA |

Note 1: Worst-case F2244 disabled

Truth Table

| \overline{OE}_1 | I_{an} | O_{an} | \overline{OE}_2 | I_{bn} | O_{bn} |
|-------------------|----------|----------|-------------------|----------|----------|
| H | X | Z | H | X | Z |
| L | H | H | L | H | H |
| L | L | L | L | L | L |

H = HIGH Voltage Level
 L = LOW Voltage Level
 X = Immaterial
 Z = High Impedance

Absolute Maximum Ratings (Note 2)

| | |
|--|--------------------------------------|
| Storage Temperature | -65°C to +150°C |
| Ambient Temperature under Bias | -55°C to +125°C |
| Junction Temperature under Bias | -55°C to +150°C |
| V _{CC} Pin Potential to Ground Pin | -0.5V to +7.0V |
| Input Voltage (Note 3) | -0.5V to +7.0V |
| Input Current (Note 3) | -30 mA to +5.0 mA |
| Voltage Applied to Output in HIGH State (with V _{CC} = 0V) | |
| Standard Output | -0.5V to V _{CC} |
| 3-STATE Output | -0.5V to +5.5V |
| Current Applied to Output in LOW State (Max) | twice the rated I _{OL} (mA) |
| ESD Last Passing Voltage (Min) | 4000V |

Recommended Operating Conditions

| | |
|------------------------------|----------------|
| Free Air Ambient Temperature | 0°C to +70°C |
| Supply Voltage | +4.5V to +5.5V |

Note 2: Absolute maximum ratings are values beyond which the device may be damaged or have its useful life impaired. Functional operation under these conditions is not implied.

Note 3: Either voltage limit or current limit is sufficient to protect inputs.

DC Electrical Characteristics

| Symbol | Parameter | Min | Typ | Max | Units | V _{CC} | Conditions |
|------------------|-----------------------------------|------|-----|--------------|-------|-----------------|---|
| V _{IH} | Input HIGH Voltage | 2.0 | | | V | | Recognized as a HIGH Signal |
| V _{IL} | Input LOW Voltage | | | 0.8 | V | | Recognized as a LOW Signal |
| V _{CD} | Input Clamp Diode Voltage | | | -1.2 | V | Min | I _{IN} = -18 mA |
| V _{OH} | Output HIGH Voltage | 2.4 | | | V | Min | I _{OH} = -3 mA 10% V _{CC} I _{OH} = -15 mA 5% V _{CC} I _{OH} = -3 mA |
| V _{OL} | Output LOW Voltage | | | 0.50 0.75 | V | Min | I _{OL} = 1 mA I _{OL} = 12 mA |
| I _{IH} | Input HIGH Current | | | 5.0 | μA | Max | V _{IN} = 2.7V |
| I _{BVI} | Input HIGH Current Breakdown Test | | | 7.0 | μA | Max | V _{IN} = 7.0V |
| I _{CEX} | Output HIGH Leakage Current | | | 50 | μA | Max | V _{OUT} = V _{CC} |
| V _{ID} | Input Leakage Test | 4.75 | | | V | 0.0 | I _{ID} = 1.9 μA All other pins grounded |
| I _{OD} | Output Leakage Circuit Current | | | 3.75 | μA | 0.0 | V _{IOD} = 150 mV All other pins grounded |
| I _{IL} | Input LOW Current | | | -1.0 -1.6 | mA | Max | V _{IN} = 0.5V (OE ₁ , OE ₂ , OE ₂) V _{IN} = 0.5V (I _n) |
| I _{OZH} | Output Leakage Current | | | 50 | μA | Max | V _{OUT} = 2.7V |
| I _{OZL} | Output Leakage Current | | | -50 | μA | Max | V _{OUT} = 0.5V |
| I _{OS} | Output Short-Circuit Current | -100 | | -225 | mA | Max | V _{OUT} = 0V |
| I _{CCH} | Power Supply Current | | 40 | 60 | mA | Max | V _O = HIGH |
| I _{CCL} | Power Supply Current | | 60 | 90 | mA | Max | V _O = LOW |
| I _{CCZ} | Power Supply Current | | 60 | 90 | mA | Max | V _O = HIGH Z |

AC Electrical Characteristics

| Symbol | Parameter | T _A = +25°C V _{CC} = +5.0V C _L = 50 pF | | | T _A = -55°C to +125°C C _L = 50 pF | | T _A = 0°C to +70°C C _L = 50 pF | | Units |
|------------------|---------------------|---|-----|------|--|-----|---|------|-------|
| | | Min | Typ | Max | Min | Max | Min | Max | |
| t _{PLH} | Propagation Delay | 1.5 | | 7.0 | 2.0 | 6.5 | 1.5 | 7.0 | ns |
| t _{PHL} | Data to Output | 2.5 | | 8.0 | 2.0 | 7.0 | 2.0 | 8.0 | |
| t _{PZH} | Output Enable Time | 1.5 | | 9.0 | 2.0 | 7.0 | 1.0 | 9.5 | ns |
| t _{PZL} | | 2.5 | | 11.5 | 2.0 | 8.5 | 2.5 | 12.0 | |
| t _{PHZ} | Output Disable Time | 1.5 | | 9.0 | 2.0 | 7.0 | 1.0 | 9.5 | |
| t _{PLZ} | | 1.5 | | 8.5 | 2.0 | 7.5 | 1.5 | 9.5 | |

Physical Dimensions inches (millimeters) unless otherwise noted

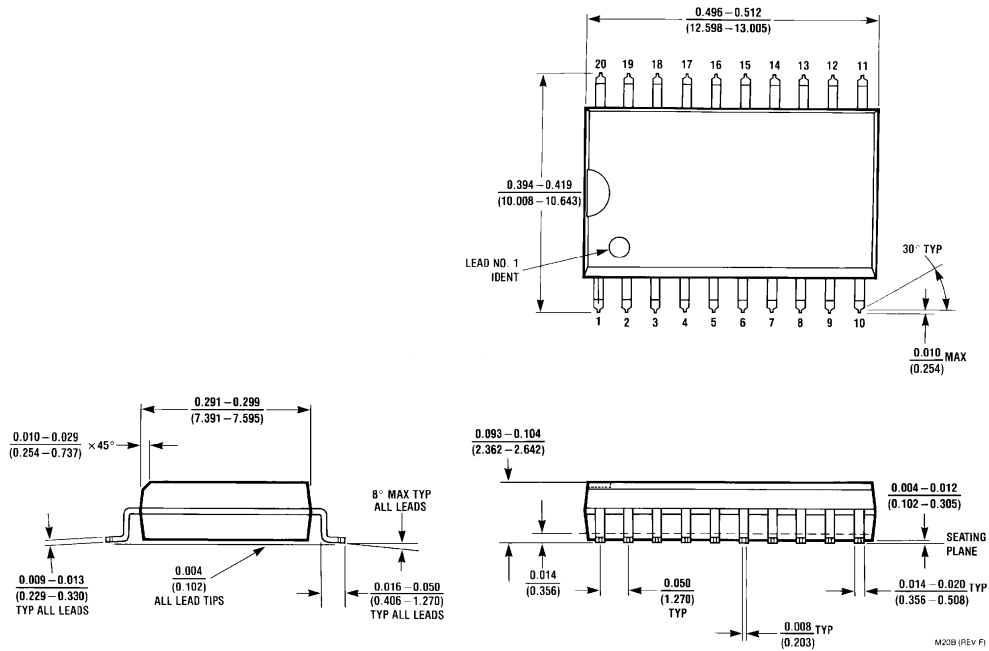

20-Lead Small Outline Integrated Circuit (SOIC), JEDEC MS-013, 0.300 Wide Package Number M20B

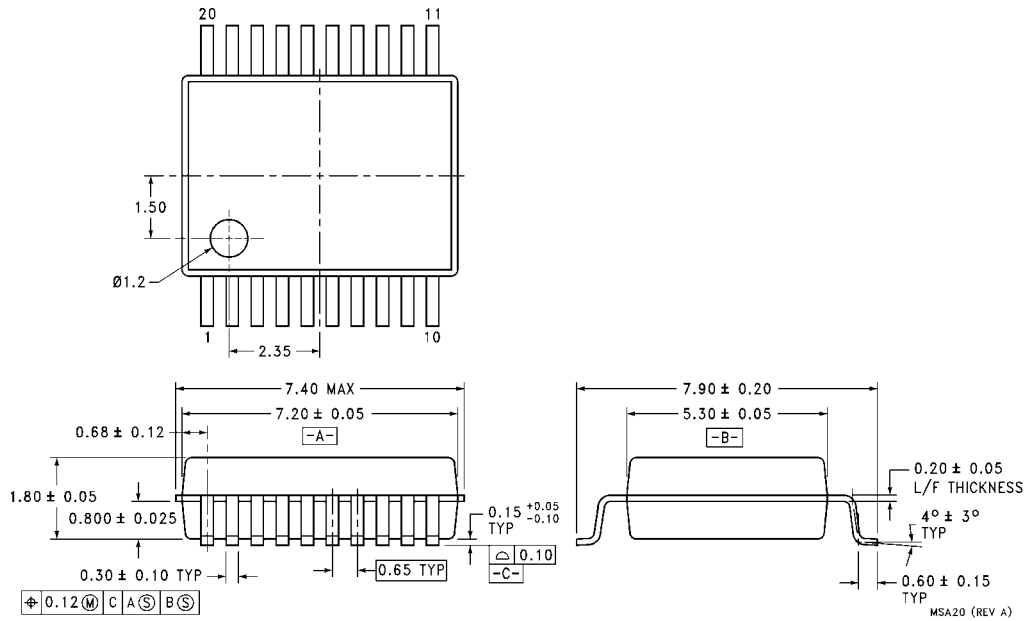

20-Lead Shrink Small Outline Package (SSOP), EIAJ TYPE II, 5.3mm Wide Package Number MSA20

Physical Dimensions inches (millimeters) unless otherwise noted (Continued)

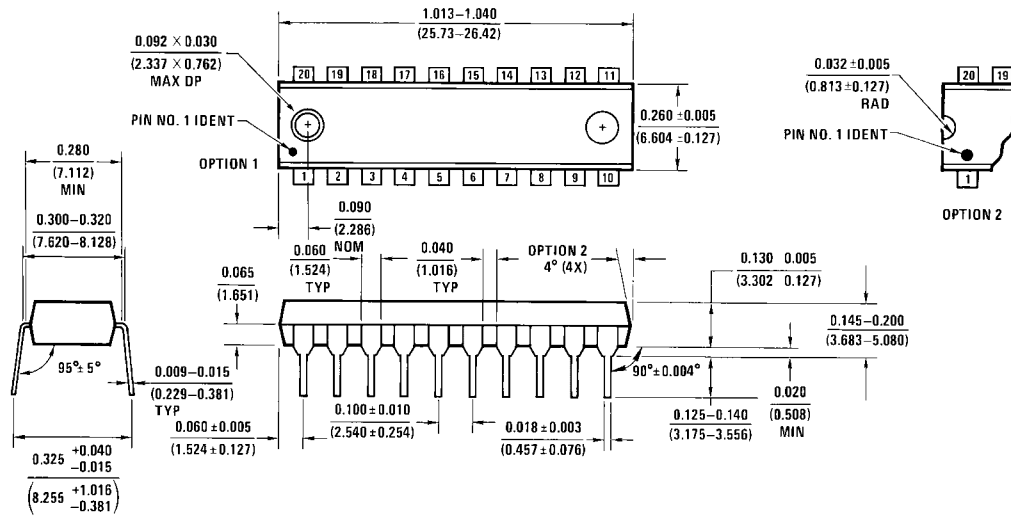

20-Lead Plastic Dual-In-Line Package (PDIP), JEDEC MS-001, 0.300 Wide Package Number N20A

LIFE SUPPORT POLICY

FAIRCHILD'S PRODUCTS ARE NOT AUTHORIZED FOR USE AS CRITICAL COMPONENTS IN LIFE SUPPORT DEVICES OR SYSTEMS WITHOUT THE EXPRESS WRITTEN APPROVAL OF THE PRESIDENT OF FAIRCHILD SEMICONDUCTOR CORPORATION. As used herein:

1. Life support devices or systems are devices or systems which, (a) are intended for surgical implant into the body, or (b) support or sustain life, and (c) whose failure to perform when properly used in accordance with instructions for use provided in the labeling, can be reasonably expected to result in a significant injury to the user.
2. A critical component in any component of a life support device or system whose failure to perform can be reasonably expected to cause the failure of the life support device or system, or to affect its safety or effectiveness.

www.fairchildsemi.com