



Chipsmall Limited consists of a professional team with an average of over 10 year of expertise in the distribution of electronic components. Based in Hongkong, we have already established firm and mutual-benefit business relationships with customers from,Europe,America and south Asia,supplying obsolete and hard-to-find components to meet their specific needs.

With the principle of “Quality Parts,Customers Priority,Honest Operation,and Considerate Service”,our business mainly focus on the distribution of electronic components. Line cards we deal with include Microchip,ALPS,ROHM,Xilinx,Pulse,ON,Everlight and Freescale. Main products comprise IC,Modules,Potentiometer,IC Socket,Relay,Connector.Our parts cover such applications as commercial,industrial, and automotives areas.

We are looking forward to setting up business relationship with you and hope to provide you with the best service and solution. Let us make a better world for our industry!



Contact us

Tel: +86-755-8981 8866 Fax: +86-755-8427 6832

Email & Skype: info@chipsmall.com Web: www.chipsmall.com

Address: A1208, Overseas Decoration Building, #122 Zhenhua RD., Futian, Shenzhen, China



74HC165; 74HCT165

8-bit parallel-in/serial out shift register

Rev. 4 — 28 December 2015

Product data sheet

1. General description

The 74HC165; 74HCT165 is an 8-bit serial or parallel-in/serial-out shift register. The device features a serial data input (DS), eight parallel data inputs (D0 to D7) and two complementary serial outputs (Q7 and $\overline{Q7}$). When the parallel load input (\overline{PL}) is LOW the data from D0 to D7 is loaded into the shift register asynchronously. When \overline{PL} is HIGH data enters the register serially at DS. When the clock enable input (\overline{CE}) is LOW data is shifted on the LOW-to-HIGH transitions of the CP input. A HIGH on \overline{CE} will disable the CP input. Inputs include clamp diodes, this enables the use of current limiting resistors to interface inputs to voltages in excess of V_{CC} .

2. Features and benefits

- Asynchronous 8-bit parallel load
- Synchronous serial input
- Complies with JEDEC standard no. 7A
- Input levels:
 - ◆ For 74HC165: CMOS level
 - ◆ For 74HCT165: TTL level
- ESD protection:
 - ◆ HBM JESD22-A114F exceeds 2000 V
 - ◆ MM JESD22-A115-A exceeds 200 V
- Specified from $-40\text{ }^{\circ}\text{C}$ to $+85\text{ }^{\circ}\text{C}$ and from $-40\text{ }^{\circ}\text{C}$ to $+125\text{ }^{\circ}\text{C}$

3. Applications

- Parallel-to-serial data conversion

4. Ordering information

Table 1. Ordering information

Type number	Package			
	Temperature range	Name	Description	Version
74HC165D	$-40\text{ }^{\circ}\text{C}$ to $+125\text{ }^{\circ}\text{C}$	SO16	plastic small outline package; 16 leads; body width 3.9 mm	SOT109-1
74HCT165D				
74HC165DB	$-40\text{ }^{\circ}\text{C}$ to $+125\text{ }^{\circ}\text{C}$	SSOP16	plastic shrink small outline package; 16 leads; body width 5.3 mm	SOT338-1
74HCT165DB				

Table 1. Ordering information ...continued

Type number	Package			Version
	Temperature range	Name	Description	
74HC165PW	-40 °C to +125 °C	TSSOP16	plastic thin shrink small outline package; 16 leads; body width 4.4 mm	SOT403-1
74HCT165PW				
74HC165BQ	-40 °C to +125 °C	DHVQFN16	plastic dual in-line compatible thermal enhanced very thin quad flat package; no leads; 16 terminals; body 2.5 × 3.5 × 0.85 mm	SOT763-1
74HCT165BQ				

5. Functional diagram

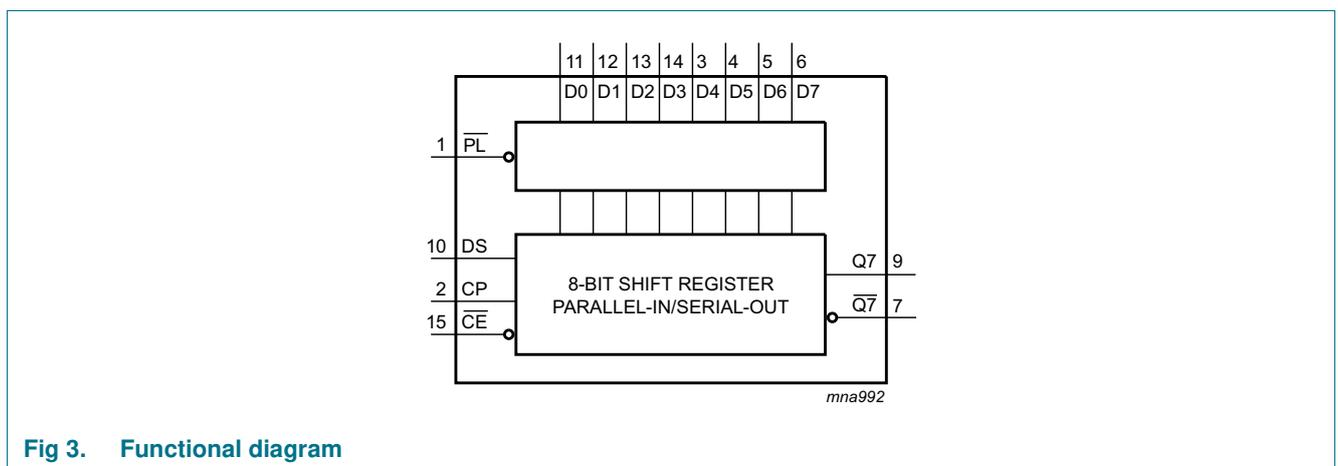
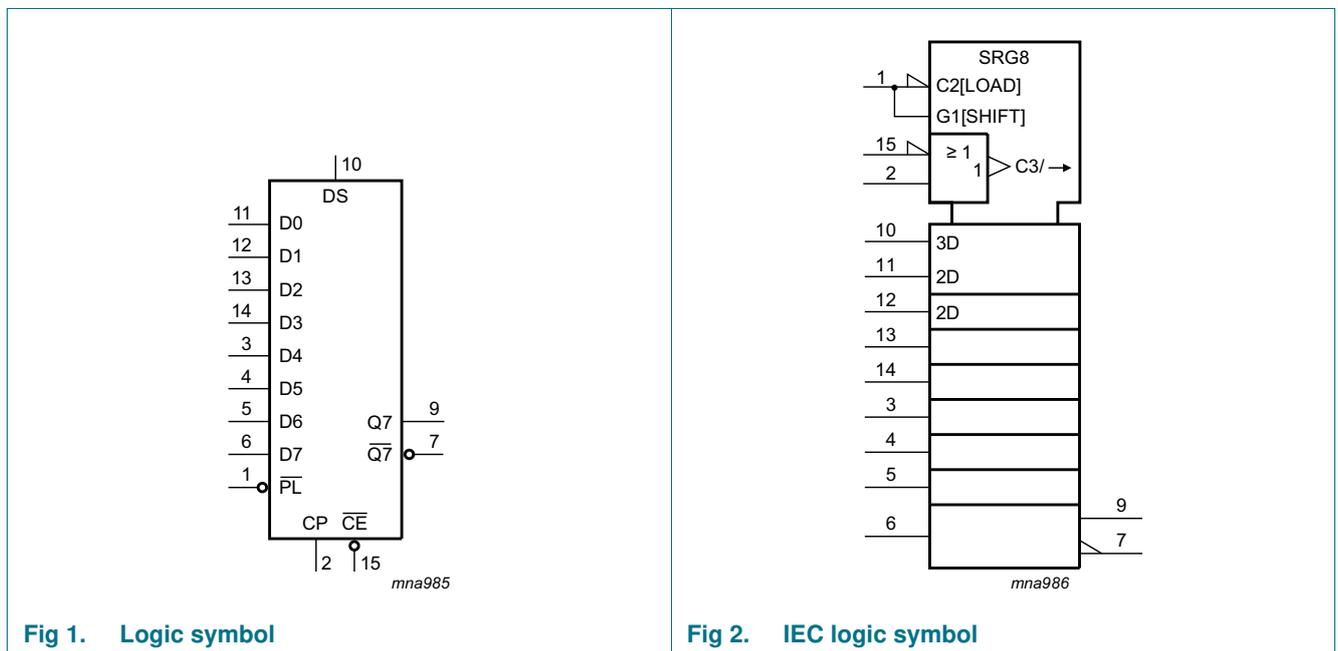

6. Pinning information

6.1 Pinning

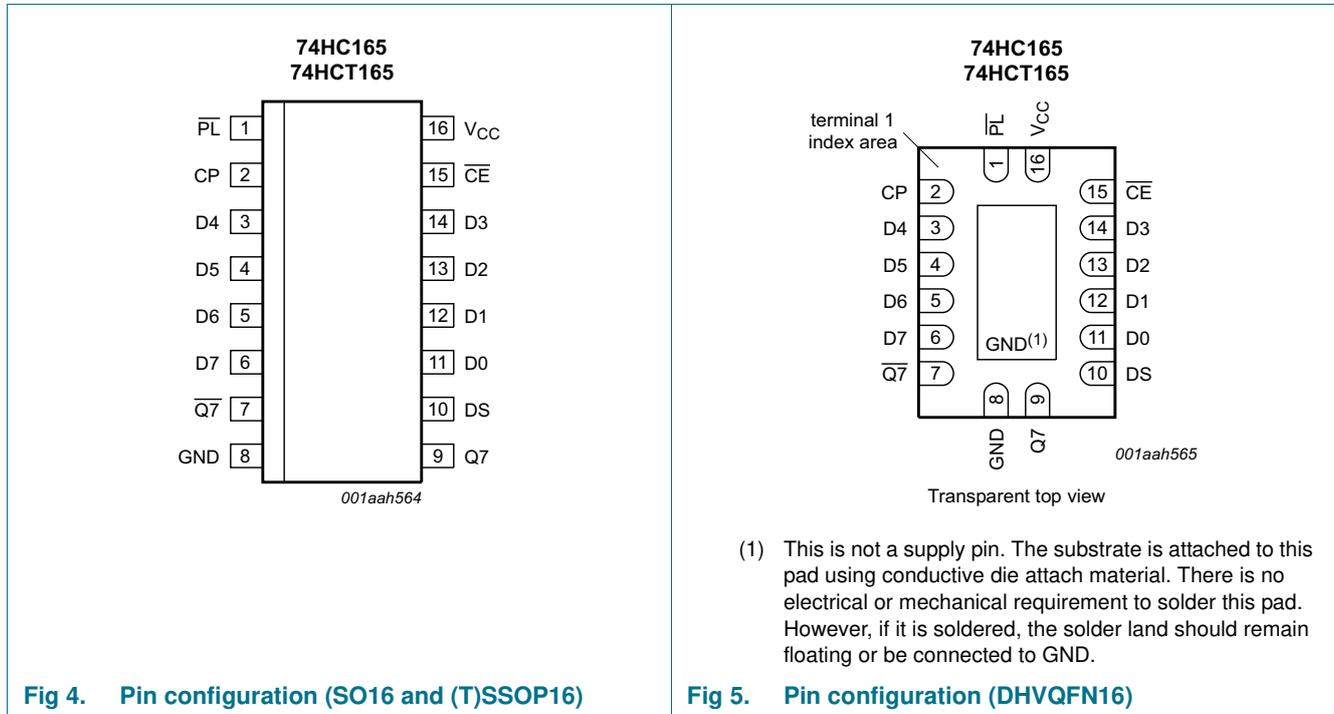

6.2 Pin description

Table 2. Pin description

Symbol	Pin	Description
\overline{PL}	1	asynchronous parallel load input (active LOW)
CP	2	clock input (LOW-to-HIGH edge-triggered)
$\overline{Q7}$	7	complementary output from the last stage
GND	8	ground (0 V)
Q7	9	serial output from the last stage
DS	10	serial data input
D0 to D7	11, 12, 13, 14, 3, 4, 5, 6	parallel data inputs (also referred to as Dn)
\overline{CE}	15	clock enable input (active LOW)
V _{CC}	16	positive supply voltage

7. Functional description

Table 3. Function table^[1]

Operating modes	Inputs					Qn registers		Outputs	
	$\overline{\text{PL}}$	$\overline{\text{CE}}$	CP	DS	D0 to D7	Q0	Q1 to Q6	Q7	$\overline{\text{Q7}}$
parallel load	L	X	X	X	L	L	L to L	L	H
	L	X	X	X	H	H	H to H	H	L
serial shift	H	L	↑	l	X	L	q0 to q5	q6	$\overline{\text{q6}}$
	H	L	↑	h	X	H	q0 to q5	q6	$\overline{\text{q6}}$
	H	↑	L	l	X	L	q0 to q5	q6	$\overline{\text{q6}}$
	H	↑	L	h	X	H	q0 to q5	q6	$\overline{\text{q6}}$
hold "do nothing"	H	H	X	X	X	q0	q1 to q6	q7	$\overline{\text{q7}}$
	H	X	H	X	X	q0	q1 to q6	q7	$\overline{\text{q7}}$

- [1] H = HIGH voltage level;
 h = HIGH voltage level one set-up time prior to the LOW-to-HIGH clock transition;
 L = LOW voltage level;
 l = LOW voltage level one set-up time prior to the LOW-to-HIGH clock transition;
 q = state of the referenced output one set-up time prior to the LOW-to-HIGH clock transition;
 X = don't care;
 ↑ = LOW-to-HIGH clock transition.

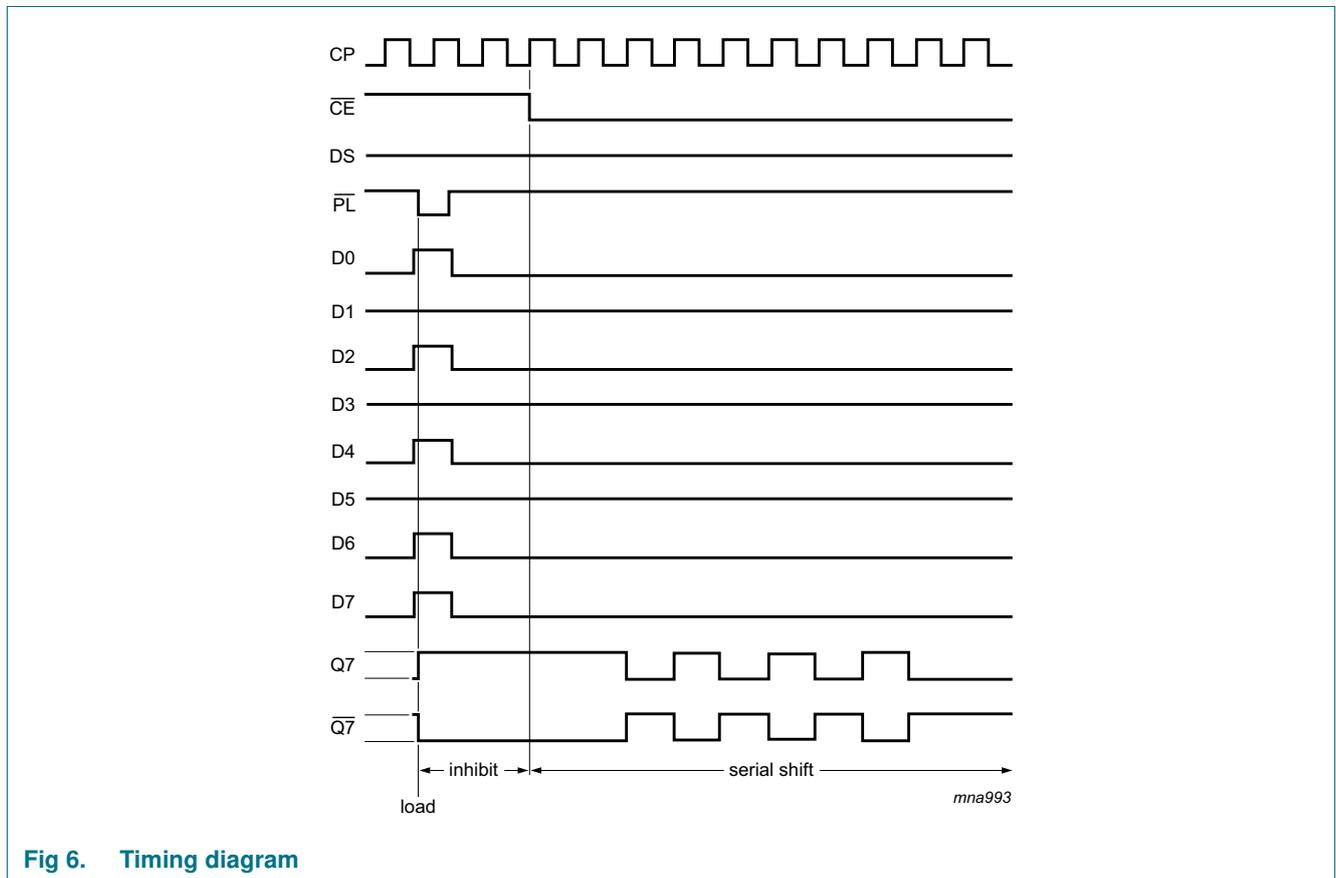

Fig 6. Timing diagram

8. Limiting values

Table 4. Limiting values

In accordance with the Absolute Maximum Rating System (IEC 60134). Voltages are referenced to GND (ground = 0 V)

Symbol	Parameter	Conditions	Min	Max	Unit
V_{CC}	supply voltage		-0.5	+7	V
I_{IK}	input clamping current	$V_I < -0.5\text{ V}$ or $V_I > V_{CC} + 0.5\text{ V}$ [1]	-	± 20	mA
I_{OK}	output clamping current	$V_O < -0.5\text{ V}$ or $V_O > V_{CC} + 0.5\text{ V}$ [1]	-	± 20	mA
I_O	output current	$-0.5\text{ V} < V_O < V_{CC} + 0.5\text{ V}$	-	± 25	mA
I_{CC}	supply current		-	50	mA
I_{GND}	ground current		-50	-	mA
T_{stg}	storage temperature		-65	+150	°C
P_{tot}	total power dissipation	$T_{amb} = -40\text{ °C}$ to $+125\text{ °C}$			
		SO16 package [2]	-	500	mW
		(T)SSOP16 package [3]	-	500	mW
		DHVQFN16 package [4]	-	500	mW

[1] The input and output voltage ratings may be exceeded if the input and output current ratings are observed.

[2] P_{tot} derates linearly with 8 mW/K above 70 °C.

[3] P_{tot} derates linearly with 5.5 mW/K above 60 °C.

[4] P_{tot} derates linearly with 4.5 mW/K above 60 °C.

9. Recommended operating conditions

Table 5. Recommended operating conditions

Voltages are referenced to GND (ground = 0 V)

Symbol	Parameter	Conditions	74HC165			74HCT165			Unit
			Min	Typ	Max	Min	Typ	Max	
V_{CC}	supply voltage		2.0	5.0	6.0	4.5	5.0	5.5	V
V_I	input voltage		0	-	V_{CC}	0	-	V_{CC}	V
V_O	output voltage		0	-	V_{CC}	0	-	V_{CC}	V
T_{amb}	ambient temperature		-40	-	+125	-40	-	+125	°C
$\Delta t/\Delta V$	input transition rise and fall rate	$V_{CC} = 2.0\text{ V}$	-	-	625	-	-	-	ns/V
		$V_{CC} = 4.5\text{ V}$	-	1.67	139	-	1.67	139	ns/V
		$V_{CC} = 6.0\text{ V}$	-	-	83	-	-	-	ns/V

10. Static characteristics

Table 6. Static characteristics

At recommended operating conditions; voltages are referenced to GND (ground = 0 V).

Symbol	Parameter	Conditions	25 °C			-40 °C to +85 °C		-40 °C to +125 °C		Unit
			Min	Typ	Max	Min	Max	Min	Max	
74HC165										
V _{IH}	HIGH-level input voltage	V _{CC} = 2.0 V	1.5	1.2	-	1.5	-	1.5	-	V
		V _{CC} = 4.5 V	3.15	2.4	-	3.15	-	3.15	-	V
		V _{CC} = 6.0 V	4.2	3.2	-	4.2	-	4.2	-	V
V _{IL}	LOW-level input voltage	V _{CC} = 2.0 V	-	0.8	0.5	-	0.5	-	0.5	V
		V _{CC} = 4.5 V	-	2.1	1.35	-	1.35	-	1.35	V
		V _{CC} = 6.0 V	-	2.8	1.8	-	1.8	-	1.8	V
V _{OH}	HIGH-level output voltage	V _I = V _{IH} or V _{IL}								
		I _O = -20 μA; V _{CC} = 2.0 V	1.9	2.0	-	1.9	-	1.9	-	V
		I _O = -20 μA; V _{CC} = 4.5 V	4.4	4.5	-	4.4	-	4.4	-	V
		I _O = -20 μA; V _{CC} = 6.0 V	5.9	6.0	-	5.9	-	5.9	-	V
		I _O = -4.0 mA; V _{CC} = 4.5 V	3.98	4.32	-	3.84	-	3.7	-	V
V _{OL}	LOW-level output voltage	V _I = V _{IH} or V _{IL}								
		I _O = 20 μA; V _{CC} = 2.0 V	-	0	0.1	-	0.1	-	0.1	V
		I _O = 20 μA; V _{CC} = 4.5 V	-	0	0.1	-	0.1	-	0.1	V
		I _O = 20 μA; V _{CC} = 6.0 V	-	0	0.1	-	0.1	-	0.1	V
		I _O = 4.0 mA; V _{CC} = 4.5 V	-	0.15	0.26	-	0.33	-	0.4	V
I _I	input leakage current	V _I = V _{CC} or GND; V _{CC} = 6.0 V	-	-	±0.1	-	±1	-	±1	μA
		I _{CC}	supply current	V _I = V _{CC} or GND; I _O = 0 A; V _{CC} = 6.0 V	-	-	8.0	-	80	-
C _I	input capacitance		-	3.5	-	-	-	-	-	pF
74HCT165										
V _{IH}	HIGH-level input voltage	V _{CC} = 4.5 V to 5.5 V	2.0	1.6	-	2.0	-	2.0	-	V
V _{IL}	LOW-level input voltage	V _{CC} = 4.5 V to 5.5 V	-	1.2	0.8	-	0.8	-	0.8	V
V _{OH}	HIGH-level output voltage	V _I = V _{IH} or V _{IL} ; V _{CC} = 4.5 V								
		I _O = -20 μA	4.4	4.5	-	4.4	-	4.4	-	V
		I _O = -4.0 mA	3.98	4.32	-	3.84	-	3.7	-	V
V _{OL}	LOW-level output voltage	V _I = V _{IH} or V _{IL} ; V _{CC} = 4.5 V								
		I _O = 20 μA; V _{CC} = 4.5 V	-	0	0.1	-	0.1	-	0.1	V
		I _O = 5.2 mA; V _{CC} = 6.0 V	-	0.16	0.26	-	0.33	-	0.4	V
I _I	input leakage current	V _I = V _{CC} or GND; V _{CC} = 6.0 V	-	-	±0.1	-	±1	-	±1	μA

Table 6. Static characteristics ...continued

At recommended operating conditions; voltages are referenced to GND (ground = 0 V).

Symbol	Parameter	Conditions	25 °C			-40 °C to +85 °C		-40 °C to +125 °C		Unit
			Min	Typ	Max	Min	Max	Min	Max	
I_{CC}	supply current	$V_I = V_{CC}$ or GND; $I_O = 0$ A; $V_{CC} = 6.0$ V	-	-	8.0	-	80	-	160	μ A
ΔI_{CC}	additional supply current	per input pin; $V_I = V_{CC} - 2.1$ V; other inputs at V_{CC} or GND; $V_{CC} = 4.5$ V to 5.5 V								
		Dn and DS inputs	-	35	126	-	157.5	-	171.5	μ A
		CP \overline{CE} , and \overline{PL} inputs	-	65	234	-	292.5	-	318.5	μ A
C_I	input capacitance		-	3.5	-	-	-	-	-	pF

11. Dynamic characteristics

Table 7. Dynamic characteristicsGND (ground = 0 V); $C_L = 50$ pF unless otherwise specified; for test circuit, see [Figure 12](#)

Symbol	Parameter	Conditions	25 °C			-40 °C to +85 °C		-40 °C to +125 °C		Unit	
			Min	Typ	Max	Min	Max	Min	Max		
74HC165											
t_{pd}	propagation delay	CP or \overline{CE} to Q7, $\overline{Q7}$; see Figure 7	[1]								
		$V_{CC} = 2.0$ V	-	52	165	-	205	-	250	ns	
		$V_{CC} = 4.5$ V	-	19	33	-	41	-	50	ns	
		$V_{CC} = 6.0$ V	-	15	28	-	35	-	43	ns	
		$V_{CC} = 5.0$ V; $C_L = 15$ pF	-	16	-	-	-	-	-	ns	
		\overline{PL} to Q7, $\overline{Q7}$; see Figure 8									
		$V_{CC} = 2.0$ V	-	50	165	-	205	-	250	ns	
		$V_{CC} = 4.5$ V	-	18	33	-	41	-	50	ns	
		$V_{CC} = 6.0$ V	-	14	28	-	35	-	43	ns	
		$V_{CC} = 5.0$ V; $C_L = 15$ pF	-	15	-	-	-	-	-	ns	
		D7 to Q7, $\overline{Q7}$; see Figure 9									
		$V_{CC} = 2.0$ V	-	36	120	-	150	-	180	ns	
		$V_{CC} = 4.5$ V	-	13	24	-	30	-	36	ns	
$V_{CC} = 6.0$ V	-	10	20	-	26	-	31	ns			
$V_{CC} = 5.0$ V; $C_L = 15$ pF	-	11	-	-	-	-	-	ns			
t_t	transition time	Q7, $\overline{Q7}$ output; see Figure 7 [2]									
		$V_{CC} = 2.0$ V	-	19	75	-	95	-	110	ns	
		$V_{CC} = 4.5$ V	-	7	15	-	19	-	22	ns	
		$V_{CC} = 6.0$ V	-	6	13	-	16	-	19	ns	

Table 7. Dynamic characteristics ...continuedGND (ground = 0 V); $C_L = 50$ pF unless otherwise specified; for test circuit, see [Figure 12](#)

Symbol	Parameter	Conditions	25 °C			–40 °C to +85 °C		–40 °C to +125 °C		Unit
			Min	Typ	Max	Min	Max	Min	Max	
t_w	pulse width	CP input HIGH or LOW; see Figure 7								
		$V_{CC} = 2.0$ V	80	17	-	100	-	120	-	ns
		$V_{CC} = 4.5$ V	16	6	-	20	-	24	-	ns
		$V_{CC} = 6.0$ V	14	5	-	17	-	20	-	ns
		\overline{PL} input LOW; see Figure 8								
		$V_{CC} = 2.0$ V	80	14	-	100	-	120	-	ns
		$V_{CC} = 4.5$ V	16	5	-	20	-	24	-	ns
	$V_{CC} = 6.0$ V	14	4	-	17	-	20	-	ns	
t_{rec}	recovery time	\overline{PL} to CP, \overline{CE} ; see Figure 8								
		$V_{CC} = 2.0$ V	100	22	-	125	-	150	-	ns
		$V_{CC} = 4.5$ V	20	8	-	25	-	30	-	ns
		$V_{CC} = 6.0$ V	17	6	-	21	-	26	-	ns
t_{su}	set-up time	DS to CP, \overline{CE} ; see Figure 10								
		$V_{CC} = 2.0$ V	80	11	-	100	-	120	-	ns
		$V_{CC} = 4.5$ V	16	4	-	20	-	24	-	ns
		$V_{CC} = 6.0$ V	14	3	-	17	-	20	-	ns
		\overline{CE} to CP and CP to \overline{CE} ; see Figure 10								
		$V_{CC} = 2.0$ V	80	17	-	100	-	120	-	ns
		$V_{CC} = 4.5$ V	16	6	-	20	-	24	-	ns
		$V_{CC} = 6.0$ V	14	5	-	17	-	20	-	ns
		Dn to \overline{PL} ; see Figure 11								
		$V_{CC} = 2.0$ V	80	22	-	100	-	120	-	ns
		$V_{CC} = 4.5$ V	16	8	-	20	-	24	-	ns
		$V_{CC} = 6.0$ V	14	6	-	17	-	20	-	ns
t_h	hold time	DS to CP, \overline{CE} and Dn to \overline{PL} ; see Figure 10								
		$V_{CC} = 2.0$ V	5	6	-	5	-	5	-	ns
		$V_{CC} = 4.5$ V	5	2	-	5	-	5	-	ns
		$V_{CC} = 6.0$ V	5	2	-	5	-	5	-	ns
		\overline{CE} to CP and CP to \overline{CE} ; see Figure 10								
		$V_{CC} = 2.0$ V	5	-17	-	5	-	5	-	ns
		$V_{CC} = 4.5$ V	5	-6	-	5	-	5	-	ns
		$V_{CC} = 6.0$ V	5	-5	-	5	-	5	-	ns

Table 7. Dynamic characteristics ...continuedGND (ground = 0 V); $C_L = 50$ pF unless otherwise specified; for test circuit, see [Figure 12](#)

Symbol	Parameter	Conditions	25 °C			-40 °C to +85 °C		-40 °C to +125 °C		Unit	
			Min	Typ	Max	Min	Max	Min	Max		
f_{\max}	maximum frequency	CP input; see Figure 7									
		$V_{CC} = 2.0$ V	6	17	-	5	-	4	-	MHz	
		$V_{CC} = 4.5$ V	30	51	-	24	-	20	-	MHz	
		$V_{CC} = 6.0$ V	35	61	-	28	-	24	-	MHz	
C_{PD}	power dissipation capacitance	per package; $V_1 = \text{GND to } V_{CC}$ ^[3]	-	35	-	-	-	-	-	pF	
74HCT165											
t_{pd}	propagation delay	\overline{CE} , CP to Q7, $\overline{Q7}$; see Figure 7 ^[1]									
		$V_{CC} = 4.5$ V	-	17	34	-	43	-	51	ns	
		$V_{CC} = 5.0$ V; $C_L = 15$ pF	-	14	-	-	-	-	-	-	ns
		\overline{PL} to Q7, $\overline{Q7}$; see Figure 8									
		$V_{CC} = 4.5$ V	-	20	40	-	50	-	60	ns	
		$V_{CC} = 5.0$ V; $C_L = 15$ pF	-	17	-	-	-	-	-	-	ns
		D7 to Q7, $\overline{Q7}$; see Figure 9									
		$V_{CC} = 4.5$ V	-	14	28	-	35	-	42	ns	
t_t	transition time	Q7, $\overline{Q7}$ output; see Figure 7 ^[2]									
		$V_{CC} = 4.5$ V	-	7	15	-	19	-	22	ns	
t_{wv}	pulse width	CP input; see Figure 7									
		$V_{CC} = 4.5$ V	16	6	-	20	-	24	-	ns	
		\overline{PL} input; see Figure 8									
t_{rec}	recovery time	\overline{PL} to CP, \overline{CE} ; see Figure 8									
		$V_{CC} = 4.5$ V	20	8	-	25	-	30	-	ns	
t_{su}	set-up time	DS to CP, \overline{CE} ; see Figure 10									
		$V_{CC} = 4.5$ V	20	2	-	25	-	30	-	ns	
		\overline{CE} to CP and CP to \overline{CE} ; see Figure 10									
		$V_{CC} = 4.5$ V	20	7	-	25	-	30	-	ns	
		Dn to \overline{PL} ; see Figure 11									
t_h	hold time	DS to CP, \overline{CE} and Dn to \overline{PL} ; see Figure 10									
		$V_{CC} = 4.5$ V	7	-1	-	9	-	11	-	ns	
		\overline{CE} to CP and CP to \overline{CE} ; see Figure 10									
	$V_{CC} = 4.5$ V	0	-7	-	0	-	0	-	ns		

Table 7. Dynamic characteristics ...continued
 GND (ground = 0 V); $C_L = 50$ pF unless otherwise specified; for test circuit, see [Figure 12](#)

Symbol	Parameter	Conditions	25 °C			-40 °C to +85 °C		-40 °C to +125 °C		Unit
			Min	Typ	Max	Min	Max	Min	Max	
f_{max}	maximum frequency	CP input; see Figure 7								
		$V_{CC} = 4.5$ V	26	44	-	21	-	17	-	MHz
		$V_{CC} = 5.0$ V; $C_L = 15$ pF	-	48	-	-	-	-	-	MHz
C_{PD}	power dissipation capacitance	per package; $V_I = GND$ to $V_{CC} - 1.5$ V [3]	-	35	-	-	-	-	-	pF

- [1] t_{pd} is the same as t_{PHL} and t_{PLH} .
- [2] t_t is the same as t_{THL} and t_{TLH} .
- [3] C_{PD} is used to determine the dynamic power dissipation (P_D in μW).
 $P_D = C_{PD} \times V_{CC}^2 \times f_i + \Sigma (C_L \times V_{CC}^2 \times f_o)$ where:
 f_i = input frequency in MHz;
 f_o = output frequency in MHz;
 $\Sigma (C_L \times V_{CC}^2 \times f_o)$ = sum of outputs;
 C_L = output load capacitance in pF;
 V_{CC} = supply voltage in V.

12. Waveforms

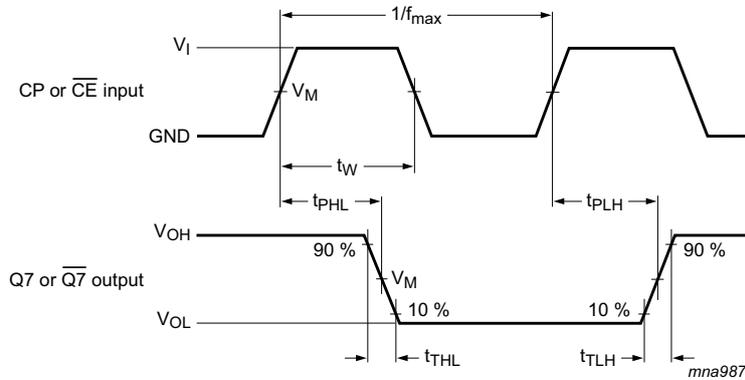

Measurement points are given in [Table 8](#).
 V_{OL} and V_{OH} are typical voltage output levels that occur with the output load.

Fig 7. The clock (CP) or clock enable (CE) to output (Q7 or Q7) propagation delays, the clock pulse width, the maximum clock frequency and the output transition times

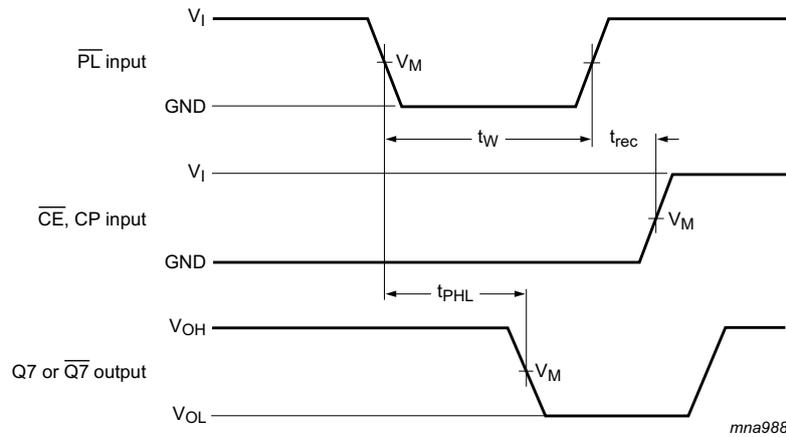

Measurement points are given in [Table 8](#).

V_{OL} and V_{OH} are typical voltage output levels that occur with the output load.

Fig 8. The parallel load (\overline{PL}) pulse width, the parallel load to output ($Q7$ or $\overline{Q7}$) propagation delays, the parallel load to clock (CP) and clock enable (CE) recovery time

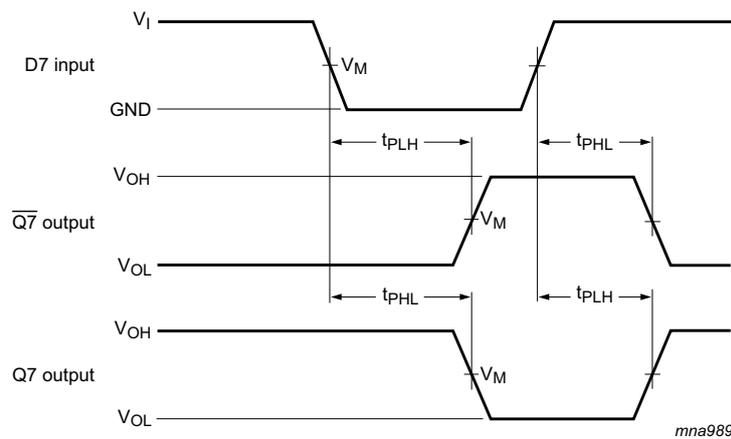

Measurement points are given in [Table 8](#).

V_{OL} and V_{OH} are typical voltage output levels that occur with the output load.

Fig 9. The data input ($D7$) to output ($Q7$ or $\overline{Q7}$) propagation delays when \overline{PL} is LOW

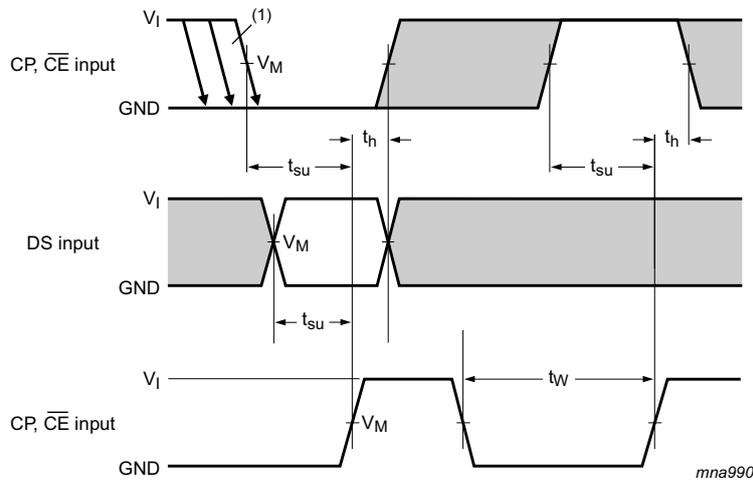

The shaded areas indicate when the input is permitted to change for predictable output performance. Measurement points are given in [Table 8](#).

V_{OL} and V_{OH} are typical voltage output levels that occur with the output load.

- (1) \overline{CE} may change only from HIGH-to-LOW while CP is LOW, see [Section 1](#).

Fig 10. The set-up and hold times from the serial data input (DS) to the clock (CP) and clock enable (\overline{CE}) inputs, from the clock enable input (CE) to the clock input (CP) and from the clock input (CP) to the clock enable input (CE)

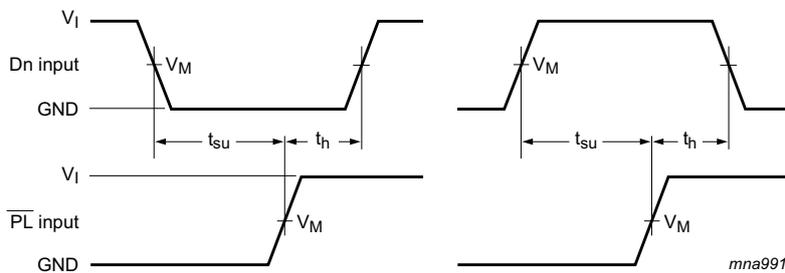

Measurement points are given in [Table 8](#).

V_{OL} and V_{OH} are typical voltage output levels that occur with the output load.

Fig 11. The set-up and hold times from the data inputs (Dn) to the parallel load input (\overline{PL})

Table 8. Measurement points

Type	Input		Output
	V_I	V_M	V_M
74HC165	V_{CC}	$0.5V_{CC}$	$0.5V_{CC}$
74HCT165	3 V	1.3 V	1.3 V

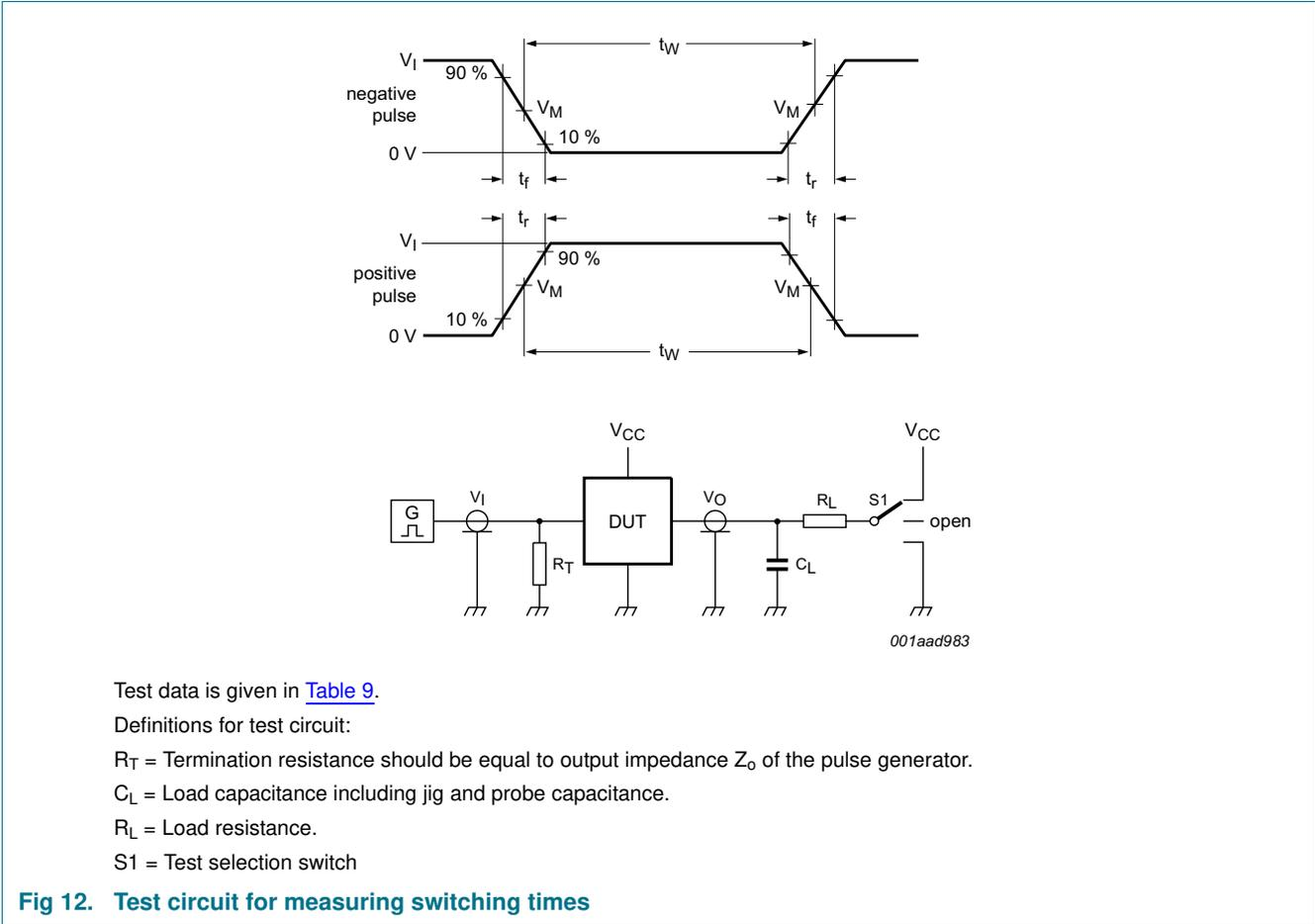

Table 9. Test data

Type	Input		Load		S1 position
	V_I	t_r, t_f	C_L	R_L	t_{PHL}, t_{PLH}
74HC165	V_{CC}	6 ns	15 pF, 50 pF	1 k Ω	open
74HCT165	3 V	6 ns	15 pF, 50 pF	1 k Ω	open

13. Package outline

SO16: plastic small outline package; 16 leads; body width 3.9 mm

SOT109-1

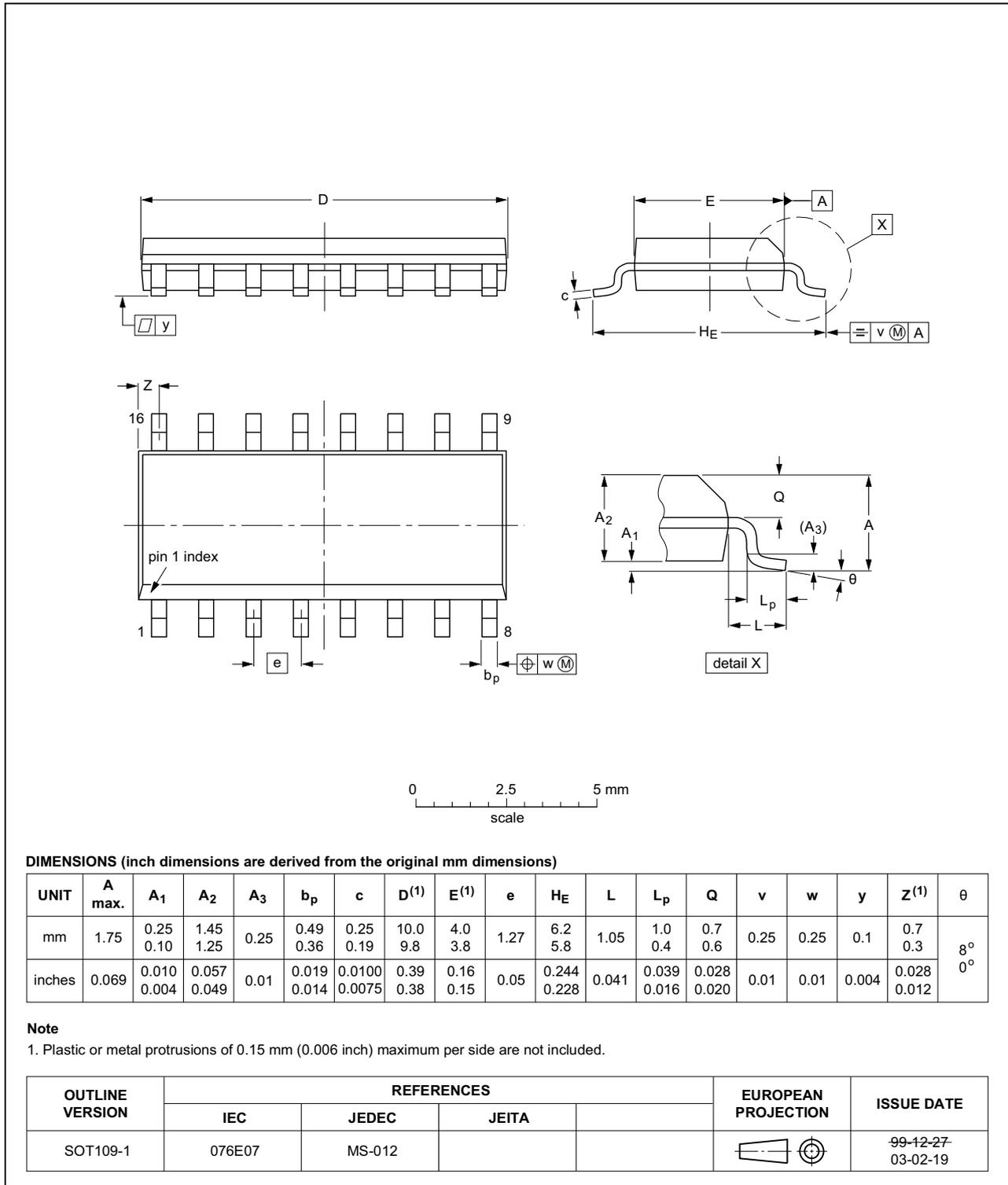

Fig 13. Package outline SOT109-1 (SO16)

SSOP16: plastic shrink small outline package; 16 leads; body width 5.3 mm

SOT338-1

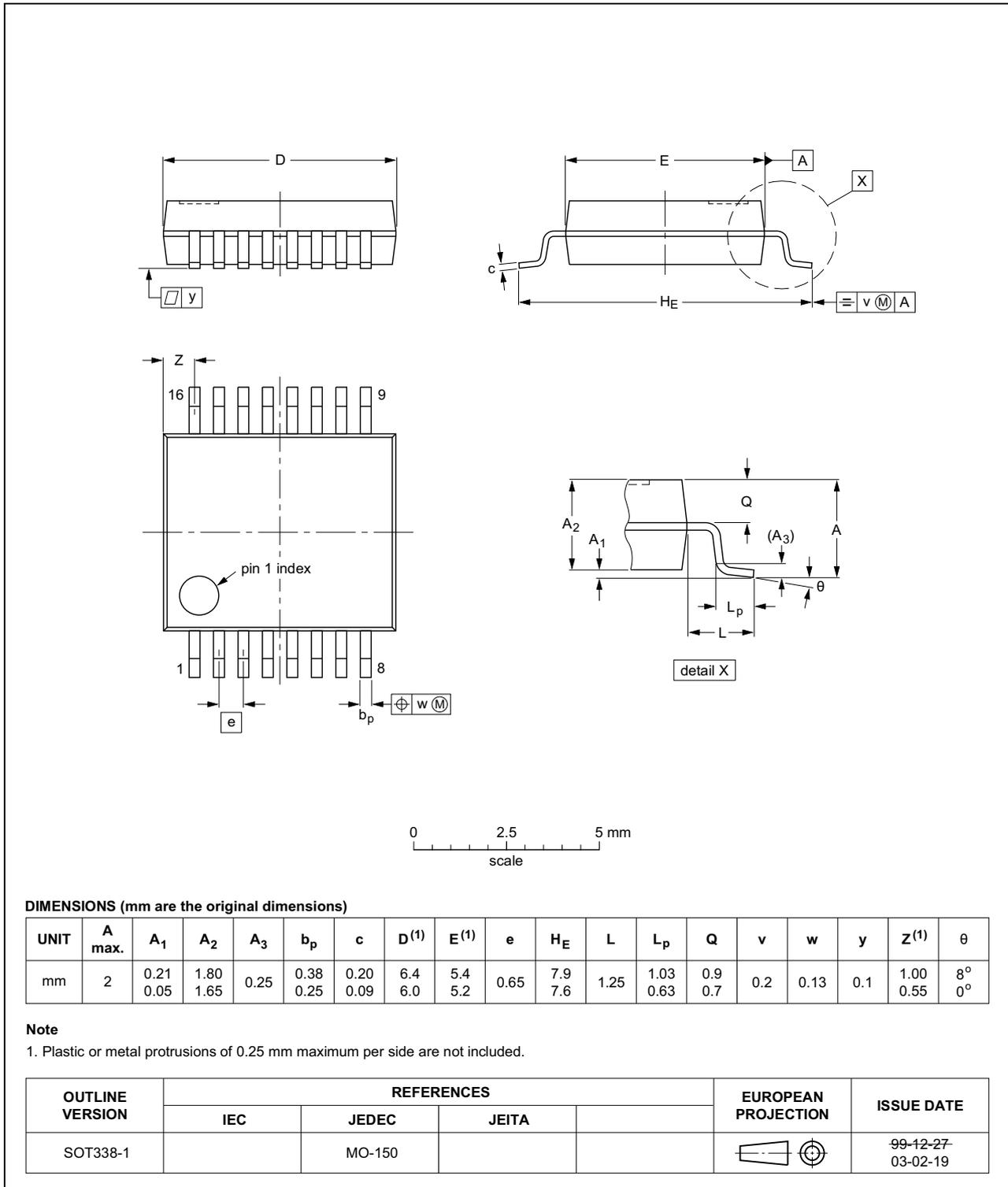

Fig 14. Package outline SOT338-1 (SSOP16)

TSSOP16: plastic thin shrink small outline package; 16 leads; body width 4.4 mm

SOT403-1

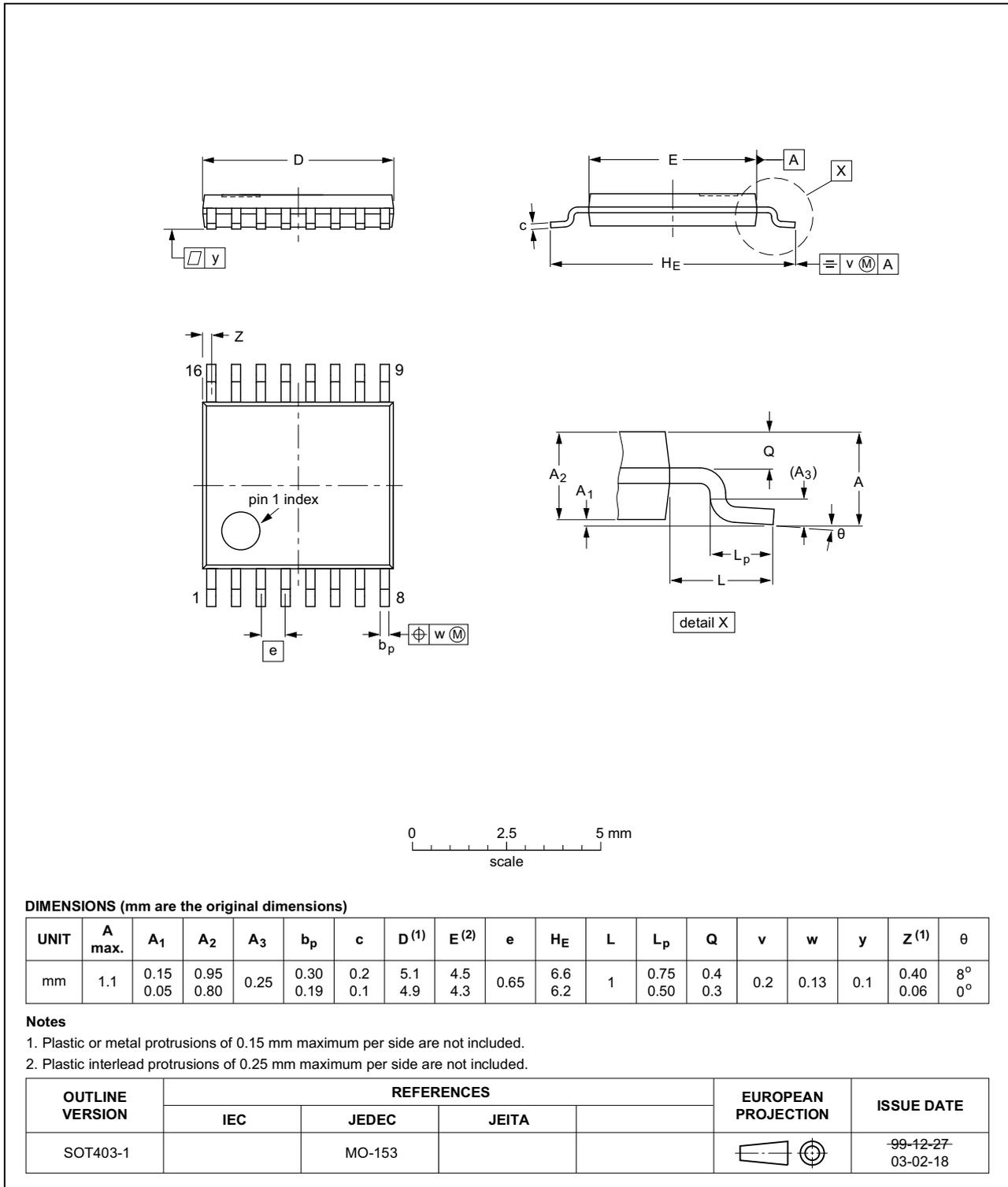

Fig 15. Package outline SOT403-1 (TSSOP16)

DHVQFN16: plastic dual in-line compatible thermal enhanced very thin quad flat package; no leads; 16 terminals; body 2.5 x 3.5 x 0.85 mm

SOT763-1

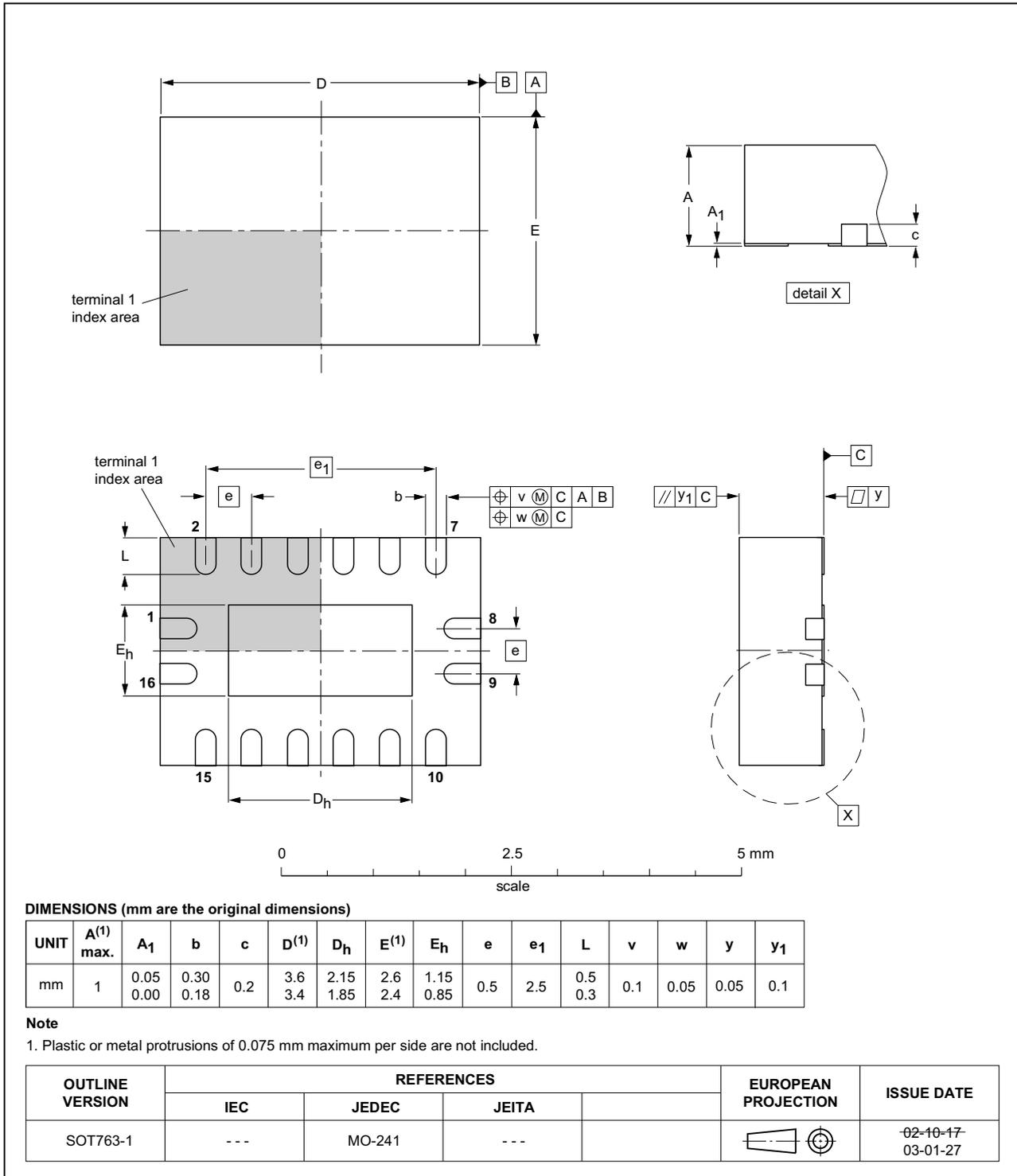

Fig 16. Package outline SOT763-1 (DHVQFN16)

14. Abbreviations

Table 10. Abbreviations

Acronym	Description
CMOS	Complementary Metal-Oxide Semiconductor
DUT	Device Under Test
ESD	ElectroStatic Discharge
HBM	Human Body Model
MM	Machine Model
TTL	Transistor-Transistor Logic

15. Revision history

Table 11. Revision history

Document ID	Release date	Data sheet status	Change notice	Supersedes
74HC_HCT165 v.4	20151228	Product data sheet	-	74HC_HCT165 v.3
Modifications:	<ul style="list-style-type: none"> Type numbers 74HC165N and 74HCT165N (SOT38-4) removed. 			
74HC_HCT165 v.3	20080314	Product data sheet	-	74HC_HCT165_CNV v.2
Modifications:	<ul style="list-style-type: none"> The format of this data sheet has been redesigned to comply with the new identity guidelines of NXP Semiconductors. Legal texts have been adapted to the new company name where appropriate. Package SOT763-1 (DHVQFN16) added to Section 4 “Ordering information” and Section 13 “Package outline”. Family data added, see Section 10 “Static characteristics” 			
74HC_HCT165_CNV v.2	December 1990	Product specification	-	-

16. Legal information

16.1 Data sheet status

Document status ^{[1][2]}	Product status ^[3]	Definition
Objective [short] data sheet	Development	This document contains data from the objective specification for product development.
Preliminary [short] data sheet	Qualification	This document contains data from the preliminary specification.
Product [short] data sheet	Production	This document contains the product specification.

[1] Please consult the most recently issued document before initiating or completing a design.

[2] The term 'short data sheet' is explained in section "Definitions".

[3] The product status of device(s) described in this document may have changed since this document was published and may differ in case of multiple devices. The latest product status information is available on the Internet at URL <http://www.nexperia.com>.

16.2 Definitions

Draft — The document is a draft version only. The content is still under internal review and subject to formal approval, which may result in modifications or additions. Nexperia does not give any representations or warranties as to the accuracy or completeness of information included herein and shall have no liability for the consequences of use of such information.

Short data sheet — A short data sheet is an extract from a full data sheet with the same product type number(s) and title. A short data sheet is intended for quick reference only and should not be relied upon to contain detailed and full information. For detailed and full information see the relevant full data sheet, which is available on request via the local Nexperia sales office. In case of any inconsistency or conflict with the short data sheet, the full data sheet shall prevail.

Product specification — The information and data provided in a Product data sheet shall define the specification of the product as agreed between Nexperia and its customer, unless Nexperia and customer have explicitly agreed otherwise in writing. In no event however, shall an agreement be valid in which the Nexperia product is deemed to offer functions and qualities beyond those described in the Product data sheet.

16.3 Disclaimers

Limited warranty and liability — Information in this document is believed to be accurate and reliable. However, Nexperia does not give any representations or warranties, expressed or implied, as to the accuracy or completeness of such information and shall have no liability for the consequences of use of such information. Nexperia takes no responsibility for the content in this document if provided by an information source outside of Nexperia.

In no event shall Nexperia be liable for any indirect, incidental, punitive, special or consequential damages (including - without limitation - lost profits, lost savings, business interruption, costs related to the removal or replacement of any products or rework charges) whether or not such damages are based on tort (including negligence), warranty, breach of contract or any other legal theory.

Notwithstanding any damages that customer might incur for any reason whatsoever, Nexperia's aggregate and cumulative liability towards customer for the products described herein shall be limited in accordance with the *Terms and conditions of commercial sale* of Nexperia.

Right to make changes — Nexperia reserves the right to make changes to information published in this document, including without limitation specifications and product descriptions, at any time and without notice. This document supersedes and replaces all information supplied prior to the publication hereof.

Suitability for use — Nexperia products are not designed, authorized or warranted to be suitable for use in life support, life-critical or safety-critical systems or equipment, nor in applications where failure or malfunction of a Nexperia product can reasonably be expected to result in personal injury, death or severe property or environmental damage. Nexperia and its suppliers accept no liability for inclusion and/or use of Nexperia products in such equipment or applications and therefore such inclusion and/or use is at the customer's own risk.

Applications — Applications that are described herein for any of these products are for illustrative purposes only. Nexperia makes no representation or warranty that such applications will be suitable for the specified use without further testing or modification.

Customers are responsible for the design and operation of their applications and products using Nexperia products, and Nexperia accepts no liability for any assistance with applications or customer product design. It is customer's sole responsibility to determine whether the Nexperia product is suitable and fit for the customer's applications and products planned, as well as for the planned application and use of customer's third party customer(s). Customers should provide appropriate design and operating safeguards to minimize the risks associated with their applications and products.

Nexperia does not accept any liability related to any default, damage, costs or problem which is based on any weakness or default in the customer's applications or products, or the application or use by customer's third party customer(s). Customer is responsible for doing all necessary testing for the customer's applications and products using Nexperia products in order to avoid a default of the applications and the products or of the application or use by customer's third party customer(s). Nexperia does not accept any liability in this respect.

Limiting values — Stress above one or more limiting values (as defined in the Absolute Maximum Ratings System of IEC 60134) will cause permanent damage to the device. Limiting values are stress ratings only and (proper) operation of the device at these or any other conditions above those given in the Recommended operating conditions section (if present) or the Characteristics sections of this document is not warranted. Constant or repeated exposure to limiting values will permanently and irreversibly affect the quality and reliability of the device.

Terms and conditions of commercial sale — Nexperia products are sold subject to the general terms and conditions of commercial sale, as published at <http://www.nexperia.com/profile/terms>, unless otherwise agreed in a valid written individual agreement. In case an individual agreement is concluded only the terms and conditions of the respective agreement shall apply. Nexperia hereby expressly objects to applying the customer's general terms and conditions with regard to the purchase of Nexperia products by customer.

No offer to sell or license — Nothing in this document may be interpreted or construed as an offer to sell products that is open for acceptance or the grant, conveyance or implication of any license under any copyrights, patents or other industrial or intellectual property rights.

Export control — This document as well as the item(s) described herein may be subject to export control regulations. Export might require a prior authorization from competent authorities.

Non-automotive qualified products — Unless this data sheet expressly states that this specific Nexperia product is automotive qualified, the product is not suitable for automotive use. It is neither qualified nor tested in accordance with automotive testing or application requirements. Nexperia accepts no liability for inclusion and/or use of non-automotive qualified products in automotive equipment or applications.

In the event that customer uses the product for design-in and use in automotive applications to automotive specifications and standards, customer (a) shall use the product without Nexperia's warranty of the product for such automotive applications, use and specifications, and (b) whenever customer uses the product for automotive applications beyond

Nexperia's specifications such use shall be solely at customer's own risk, and (c) customer fully indemnifies Nexperia for any liability, damages or failed product claims resulting from customer design and use of the product for automotive applications beyond Nexperia's standard warranty and Nexperia's product specifications.

Translations — A non-English (translated) version of a document is for reference only. The English version shall prevail in case of any discrepancy between the translated and English versions.

16.4 Trademarks

Notice: All referenced brands, product names, service names and trademarks are the property of their respective owners.

17. Contact information

For more information, please visit: <http://www.nexperia.com>

For sales office addresses, please send an email to: salesaddresses@nexperia.com

18. Contents

1	General description	1
2	Features and benefits	1
3	Applications	1
4	Ordering information	1
5	Functional diagram	2
6	Pinning information	3
6.1	Pinning	3
6.2	Pin description	3
7	Functional description	4
8	Limiting values	5
9	Recommended operating conditions	5
10	Static characteristics	6
11	Dynamic characteristics	7
12	Waveforms	10
13	Package outline	14
14	Abbreviations	18
15	Revision history	18
16	Legal information	19
16.1	Data sheet status	19
16.2	Definitions	19
16.3	Disclaimers	19
16.4	Trademarks	20
17	Contact information	20
18	Contents	21