



Chipsmall Limited consists of a professional team with an average of over 10 year of expertise in the distribution of electronic components. Based in Hongkong, we have already established firm and mutual-benefit business relationships with customers from,Europe,America and south Asia,supplying obsolete and hard-to-find components to meet their specific needs.

With the principle of “Quality Parts,Customers Priority,Honest Operation,and Considerate Service”,our business mainly focus on the distribution of electronic components. Line cards we deal with include Microchip,ALPS,ROHM,Xilinx,Pulse,ON,Everlight and Freescale. Main products comprise IC,Modules,Potentiometer,IC Socket,Relay,Connector.Our parts cover such applications as commercial,industrial, and automotives areas.

We are looking forward to setting up business relationship with you and hope to provide you with the best service and solution. Let us make a better world for our industry!



Contact us

Tel: +86-755-8981 8866 Fax: +86-755-8427 6832

Email & Skype: info@chipsmall.com Web: www.chipsmall.com

Address: A1208, Overseas Decoration Building, #122 Zhenhua RD., Futian, Shenzhen, China



Important notice

Dear Customer,

On 7 February 2017 the former NXP Standard Product business became a new company with the tradename **Nexperia**. Nexperia is an industry leading supplier of Discrete, Logic and PowerMOS semiconductors with its focus on the automotive, industrial, computing, consumer and wearable application markets

In data sheets and application notes which still contain NXP or Philips Semiconductors references, use the references to Nexperia, as shown below.

Instead of <http://www.nxp.com>, <http://www.philips.com/> or <http://www.semiconductors.philips.com/>, use <http://www.nexperia.com>

Instead of sales.addresses@www.nxp.com or sales.addresses@www.semiconductors.philips.com, use salesaddresses@nexperia.com (email)

Replace the copyright notice at the bottom of each page or elsewhere in the document, depending on the version, as shown below:

- © NXP N.V. (year). All rights reserved or © Koninklijke Philips Electronics N.V. (year). All rights reserved

Should be replaced with:

- © **Nexperia B.V. (year). All rights reserved.**

If you have any questions related to the data sheet, please contact our nearest sales office via e-mail or telephone (details via salesaddresses@nexperia.com). Thank you for your cooperation and understanding,

Kind regards,

Team Nexperia

74HC259-Q100; 74HCT259-Q100

8-bit addressable latch

Rev. 1 — 30 July 2012

Product data sheet

1. General description

The 74HC259-Q100; 74HCT259-Q100 are high-speed Si-gate CMOS devices and are pin compatible with Low-power Schottky TTL (LSTTL). They are specified in compliance with JEDEC standard No. 7A.

The 74HC259-Q100; 74HCT259-Q100 are high-speed 8-bit addressable latches designed for general-purpose storage applications in digital systems. They are multifunctional devices capable of storing single-line data in eight addressable latches and providing a 3-to-8 decoder and multiplexer function with active HIGH outputs (Q0 to Q7). They also incorporate an active LOW common reset (MR) for resetting all latches as well as an active LOW enable input (LE).

The 74HC259-Q100; 74HCT259-Q100 has four modes of operation:

- Addressable latch mode, in this mode data on the data line (D) is written into the addressed latch. The addressed latch follows the data input with all non-addressed latches remaining in their previous states.
- Memory mode, in this mode all latches remain in their previous states and are unaffected by the data or address inputs.
- Demultiplexing mode (or 3-to-8 decoding), in this mode the addressed output follows the state of the data input (D) with all other outputs in the LOW state.
- Reset mode, in this mode all outputs are LOW and unaffected by the address inputs (A0 to A2) and data input (D).

When operating the 74HC259-Q100; 74HCT259-Q100 as an address latch, changing more than one address bit could impose a transient wrong address. Therefore, this should only be done while in the Memory mode.

This product has been qualified to the Automotive Electronics Council (AEC) standard Q100 (Grade 1) and is suitable for use in automotive applications.

2. Features and benefits

- Automotive product qualification in accordance with AEC-Q100 (Grade 1)
 - ◆ Specified from $-40\text{ }^{\circ}\text{C}$ to $+85\text{ }^{\circ}\text{C}$ and from $-40\text{ }^{\circ}\text{C}$ to $+125\text{ }^{\circ}\text{C}$
- Combined demultiplexer and 8-bit latch
- Serial-to-parallel capability
- Output from each storage bit available
- Random (addressable) data entry
- Easily expandable
- Common reset input



- Useful as a 3-to-8 active HIGH decoder
- Input levels:
 - ◆ For 74HC259-Q100: CMOS level
 - ◆ For 74HCT259-Q100: TTL level
- ESD protection:
 - ◆ MIL-STD-883, method 3015 exceeds 2000 V
 - ◆ HBM JESD22-A114F exceeds 2000 V
 - ◆ MM JESD22-A115-A exceeds 200 V (C = 200 pF, R = 0 Ω)
- Multiple package options

3. Ordering information

Table 1. Ordering information

Type number	Package			Version
	Temperature range	Name	Description	
74HC259D-Q100 74HCT259D-Q100	-40 °C to +125 °C	SO16	plastic small outline package; 16 leads; body width 3.9 mm	SOT109-1
74HC259PW-Q100 74HCT259PW-Q100	-40 °C to +125 °C	TSSOP16	plastic thin shrink small outline package; 16 leads; body width 4.4 mm	SOT403-1
74HC259BQ-Q100 74HCT259BQ-Q100	-40 °C to +125 °C	DHVQFN16	plastic dual in-line compatible thermal enhanced very thin quad flat package; no leads; 16 terminals; body 2.5 × 3.5 × 0.85 mm	SOT763-1

4. Functional diagram

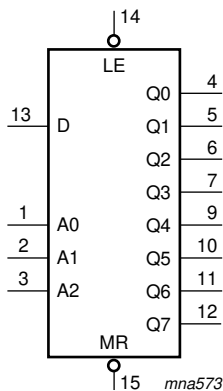

Fig 1. Logic symbol

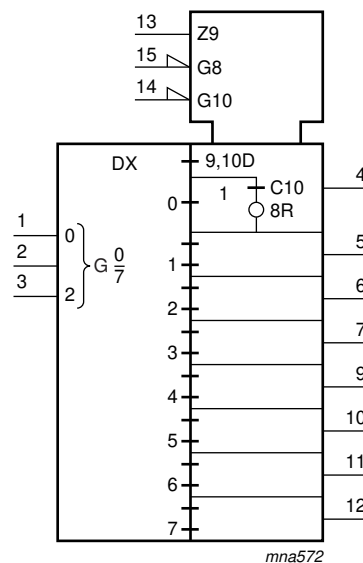

Fig 2. IEC logic symbol

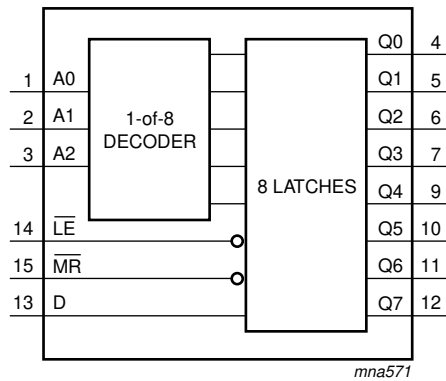

Fig 3. Functional diagram

5. Pinning information

5.1 Pinning

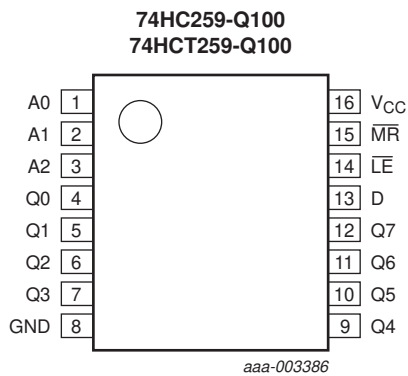
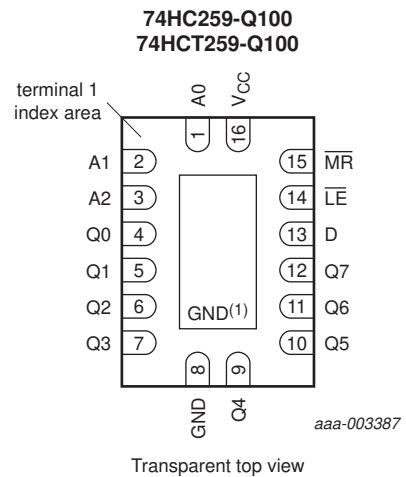

Fig 4. Pin configuration (SO16 and TSSOP16)



- (1) The die substrate is attached to this pad using conductive die attach material. It cannot be used as supply pin or input.

Fig 5. Pin configuration (DHVQFN16)

5.2 Pin description

Table 2. Pin description

Symbol	Pin	Description
A0, A1, A2	1, 2, 3	address input
Q0, Q1, Q2, Q3, Q4, Q5, Q6, Q7	4, 5, 6, 7, 9, 10, 11, 12	latch output
GND	8	ground (0 V)
D	13	data input
$\overline{\text{LE}}$	14	latch enable input (active LOW)
$\overline{\text{MR}}$	15	conditional reset input (active LOW)
V _{CC}	16	supply voltage

6. Functional description

Table 3. Function table^[1]

Operating mode	Input						Output							
	$\overline{\text{MR}}$	$\overline{\text{LE}}$	D	A0	A1	A2	Q0	Q1	Q2	Q3	Q4	Q5	Q6	Q7
Reset (clear)	L	H	X	X	X	X	L	L	L	L	L	L	L	L
Demultiplexer (active HIGH 8-channel) decoder (when D = H)	L	L	d	L	L	L	Q = d	L	L	L	L	L	L	L
	L	L	d	H	L	L	L	Q = d	L	L	L	L	L	L
	L	L	d	L	H	L	L	L	Q = d	L	L	L	L	L
	L	L	d	H	H	L	L	L	L	Q = d	L	L	L	L
	L	L	d	L	L	H	L	L	L	L	Q = d	L	L	L
	L	L	d	H	L	H	L	L	L	L	L	Q = d	L	L
	L	L	d	L	H	H	L	L	L	L	L	L	Q = d	L
	L	L	d	H	H	H	L	L	L	L	L	L	L	Q = d
Memory (no action)	H	H	X	X	X	X	q ₀	q ₁	q ₂	q ₃	q ₄	q ₅	q ₆	q ₇
Addressable latch	H	L	d	L	L	L	Q = d	q ₁	q ₂	q ₃	q ₄	q ₅	q ₆	q ₇
	H	L	d	H	L	L	q ₀	Q = d	q ₂	q ₃	q ₄	q ₅	q ₆	q ₇
	H	L	d	L	H	L	q ₀	q ₁	Q = d	q ₃	q ₄	q ₅	q ₆	q ₇
	H	L	d	H	H	L	q ₀	q ₁	q ₂	Q = d	q ₄	q ₅	q ₆	q ₇
	H	L	d	L	L	H	q ₀	q ₁	q ₂	q ₃	Q = d	q ₅	q ₆	q ₇
	H	L	d	H	L	H	q ₀	q ₁	q ₂	q ₃	q ₄	Q = d	q ₆	q ₇
	H	L	d	L	H	H	q ₀	q ₁	q ₂	q ₃	q ₄	q ₅	Q = d	q ₇
	H	L	d	H	H	H	q ₀	q ₁	q ₂	q ₃	q ₄	q ₅	q ₆	Q = d

[1] H = HIGH voltage level;

L = LOW voltage level;

X = don't care;

d = HIGH or LOW data one set-up time prior to the LOW-to-HIGH $\overline{\text{LE}}$ transition;

q = lower case letter indicates the state of the referenced input one set-up time prior to the LOW-to-HIGH transition.

Table 4. Operating mode select table^[1]

LE	MR	Mode
L	H	Addressable latch mode
H	H	Memory mode
L	L	Demultiplexer mode
H	L	Reset mode

[1] H = HIGH voltage level; L = LOW voltage level.

7. Limiting values

Table 5. Limiting values

In accordance with the Absolute Maximum Rating System (IEC 60134). Voltages are referenced to GND (ground = 0 V).

Symbol	Parameter	Conditions	Min	Max	Unit
V_{CC}	supply voltage		-0.5	+7.0	V
I_{IK}	input clamping current	$V_I < -0.5\text{ V}$ or $V_I > V_{CC} + 0.5\text{ V}$	^[1] -	±20	mA
I_{OK}	output clamping current	$V_O < -0.5\text{ V}$ or $V_O > V_{CC} + 0.5\text{ V}$	^[1] -	±20	mA
I_O	output current	$V_O = -0.5\text{ V}$ to $V_{CC} + 0.5\text{ V}$	-	±25	mA
I_{CC}	supply current		-	+70	mA
I_{GND}	ground current		-70	-	mA
T_{stg}	storage temperature		-65	+150	°C
P_{tot}	total power dissipation		^[2] -	500	mW

[1] The input and output voltage ratings may be exceeded if the input and output current ratings are observed.

[2] For SO16 package: P_{tot} derates linearly with 8 mW/K above 70 °C.
 For TSSOP16 package: P_{tot} derates linearly with 5.5 mW/K above 60 °C.
 For DHVQFN16 package: P_{tot} derates linearly with 4.5 mW/K above 60 °C.

8. Recommended operating conditions

Table 6. Recommended operating conditions

Voltages are referenced to GND (ground = 0 V)

Symbol	Parameter	Conditions	74HC259-Q100			74HCT259-Q100			Unit
			Min	Typ	Max	Min	Typ	Max	
V _{CC}	supply voltage		2.0	5.0	6.0	4.5	5.0	5.5	V
V _I	input voltage		0	-	V _{CC}	0	-	V _{CC}	V
V _O	output voltage		0	-	V _{CC}	0	-	V _{CC}	V
T _{amb}	ambient temperature		-40	-	+125	-40	-	+125	°C
Δt/ΔV	input transition rise and fall rate	V _{CC} = 2.0 V	-	-	625	-	-	-	ns/V
		V _{CC} = 4.5 V	-	1.67	139	-	1.67	139	ns/V
		V _{CC} = 6.0 V	-	-	83	-	-	-	ns/V

9. Static characteristics

Table 7. Static characteristics

At recommended operating conditions; voltages are referenced to GND (ground = 0 V).

Symbol	Parameter	Conditions	25 °C			-40 °C to +85 °C		-40 °C to +125 °C		Unit
			Min	Typ	Max	Min	Max	Min	Max	
74HC259-Q100										
V _{IH}	HIGH-level input voltage	V _{CC} = 2.0 V	1.5	1.2	-	1.5	-	1.5	-	V
		V _{CC} = 4.5 V	3.15	2.4	-	3.15	-	3.15	-	V
		V _{CC} = 6.0 V	4.2	3.2	-	4.2	-	4.2	-	V
V _{IL}	LOW-level input voltage	V _{CC} = 2.0 V	-	0.8	0.5	-	0.5	-	0.5	V
		V _{CC} = 4.5 V	-	2.1	1.35	-	1.35	-	1.35	V
		V _{CC} = 6.0 V	-	2.8	1.8	-	1.8	-	1.8	V
V _{OH}	HIGH-level output voltage	V _I = V _{IH} or V _{IL}								
		I _O = -20 μA; V _{CC} = 2.0 V	1.9	2.0	-	1.9	-	1.9	-	V
		I _O = -20 μA; V _{CC} = 4.5 V	4.4	4.5	-	4.4	-	4.4	-	V
		I _O = -20 μA; V _{CC} = 6.0 V	5.9	6.0	-	5.9	-	5.9	-	V
		I _O = -4.0 mA; V _{CC} = 4.5 V	3.98	4.32	-	3.84	-	3.7	-	V
V _{OL}	LOW-level output voltage	V _I = V _{IH} or V _{IL}								
		I _O = 20 μA; V _{CC} = 2.0 V	-	0	0.1	-	0.1	-	0.1	V
		I _O = 20 μA; V _{CC} = 4.5 V	-	0	0.1	-	0.1	-	0.1	V
		I _O = 20 μA; V _{CC} = 6.0 V	-	0	0.1	-	0.1	-	0.1	V
		I _O = 4.0 mA; V _{CC} = 4.5 V	-	0.15	0.26	-	0.33	-	0.4	V
I _I	input leakage current	V _I = V _{CC} or GND; V _{CC} = 6.0 V	-	-	±0.1	-	±1	-	±1	μA
		V _I = V _{CC} or GND; I _O = 0 A; V _{CC} = 6.0 V	-	-	8.0	-	80	-	160	μA

Table 7. Static characteristics ...continued

At recommended operating conditions; voltages are referenced to GND (ground = 0 V).

Symbol	Parameter	Conditions	25 °C			-40 °C to +85 °C		-40 °C to +125 °C		Unit
			Min	Typ	Max	Min	Max	Min	Max	
C_I	input capacitance		-	3.5	-	-	-	-	-	pF
74HCT259-Q100										
V_{IH}	HIGH-level input voltage	$V_{CC} = 4.5\text{ V to }5.5\text{ V}$	2.0	1.6	-	2.0	-	2.0	-	V
V_{IL}	LOW-level input voltage	$V_{CC} = 4.5\text{ V to }5.5\text{ V}$	-	1.2	0.8	-	0.8	-	0.8	V
V_{OH}	HIGH-level output voltage	$V_I = V_{IH}\text{ or }V_{IL}; V_{CC} = 4.5\text{ V}$								
		$I_O = -20\ \mu\text{A}$	4.4	4.5	-	4.4	-	4.4	-	V
		$I_O = -4.0\text{ mA}$	3.98	4.32	-	3.84	-	3.7	-	V
V_{OL}	LOW-level output voltage	$V_I = V_{IH}\text{ or }V_{IL}; V_{CC} = 4.5\text{ V}$								
		$I_O = 20\ \mu\text{A}; V_{CC} = 4.5\text{ V}$	-	0	0.1	-	0.1	-	0.1	V
		$I_O = 5.2\text{ mA}; V_{CC} = 6.0\text{ V}$	-	0.15	0.26	-	0.33	-	0.4	V
I_I	input leakage current	$V_I = V_{CC}\text{ or GND}; V_{CC} = 5.5\text{ V}$	-	-	± 0.1	-	± 1	-	± 1	μA
I_{CC}	supply current	$V_I = V_{CC}\text{ or GND}; I_O = 0\text{ A}; V_{CC} = 5.5\text{ V}$	-	-	8.0	-	80	-	160	μA
ΔI_{CC}	additional supply current	$V_I = V_{CC} - 2.1\text{ V}; I_O = 0\text{ A};$ other inputs at $V_{CC}\text{ or GND};$ $V_{CC} = 4.5\text{ V to }5.5\text{ V}$								
		pin An, \overline{LE}	-	150	540	-	675	-	735	μA
		pin D	-	120	432	-	540	-	588	μA
		pin \overline{MR}	-	75	270	-	338	-	368	μA
C_I	input capacitance		-	3.5	-	-	-	-	-	pF

10. Dynamic characteristics

Table 8. Dynamic characteristics

Voltages are referenced to GND (ground = 0 V); for test circuit see [Figure 12](#).

Symbol	Parameter	Conditions	25 °C			-40 °C to +85 °C		-40 °C to +125 °C		Unit
			Min	Typ ^[1]	Max	Min	Max	Min	Max	
74HC259-Q100										
t _{pd}	propagation delay	D to Qn; see Figure 6 ^[2]								
		V _{CC} = 2.0 V	-	58	185	-	230	-	280	ns
		V _{CC} = 4.5 V	-	21	37	-	46	-	56	ns
		V _{CC} = 5.0 V; C _L = 15 pF	-	18	-	-	-	-	-	ns
		V _{CC} = 6.0 V	-	17	31	-	39	-	48	ns
		An to Qn; see Figure 7 ^[2]								
		V _{CC} = 2.0 V	-	58	185	-	230	-	280	ns
		V _{CC} = 4.5 V	-	21	37	-	46	-	56	ns
		V _{CC} = 5.0 V; C _L = 15 pF	-	17	-	-	-	-	-	ns
		V _{CC} = 6.0 V	-	17	31	-	39	-	48	ns
		$\overline{\text{LE}}$ to Qn; see Figure 8 ^[2]								
		V _{CC} = 2.0 V	-	55	170	-	215	-	255	ns
V _{CC} = 4.5 V	-	20	34	-	43	-	51	ns		
V _{CC} = 5.0 V; C _L = 15 pF	-	17	-	-	-	-	-	ns		
V _{CC} = 6.0 V	-	16	29	-	37	-	43	ns		
t _{PHL}	HIGH to LOW propagation delay	$\overline{\text{MR}}$ to Qn; see Figure 9								
		V _{CC} = 2.0 V	-	50	155	-	195	-	235	ns
		V _{CC} = 4.5 V	-	18	31	-	39	-	47	ns
		V _{CC} = 5.0 V; C _L = 15 pF	-	15	-	-	-	-	-	ns
V _{CC} = 6.0 V	-	14	26	-	33	-	40	ns		
t _t	transition time	see Figure 8 ^[3]								
		V _{CC} = 2.0 V	-	19	75	-	95	-	119	ns
		V _{CC} = 4.5 V	-	7	15	-	19	-	22	ns
V _{CC} = 6.0 V	-	6	13	-	16	-	19	ns		
t _w	pulse width	$\overline{\text{LE}}$ HIGH or LOW; see Figure 8								
		V _{CC} = 2.0 V	70	17	-	90	-	105	-	ns
		V _{CC} = 4.5 V	14	6	-	18	-	21	-	ns
		V _{CC} = 6.0 V	12	5	-	15	-	18	-	ns
		$\overline{\text{MR}}$ LOW; see Figure 9								
		V _{CC} = 2.0 V	70	17	-	90	-	105	-	ns
		V _{CC} = 4.5 V	14	6	-	18	-	21	-	ns
		V _{CC} = 6.0 V	12	5	-	15	-	18	-	ns

Table 8. Dynamic characteristics ...continued

Voltages are referenced to GND (ground = 0 V); for test circuit see [Figure 12](#).

Symbol	Parameter	Conditions	25 °C			-40 °C to +85 °C		-40 °C to +125 °C		Unit
			Min	Typ ^[1]	Max	Min	Max	Min	Max	
t _{su}	set-up time	D, An to $\overline{\text{LE}}$; see Figure 10 and Figure 11								
		V _{CC} = 2.0 V	80	19	-	100	-	120	-	ns
		V _{CC} = 4.5 V	16	7	-	20	-	24	-	ns
		V _{CC} = 6.0 V	14	6	-	17	-	20	-	ns
t _h	hold time	D to $\overline{\text{LE}}$; see Figure 10 and Figure 11								
		V _{CC} = 2.0 V	0	-19	-	0	-	0	-	ns
		V _{CC} = 4.5 V	0	-6	-	0	-	0	-	ns
		V _{CC} = 6.0 V	0	-5	-	0	-	0	-	ns
		An to $\overline{\text{LE}}$; see Figure 10 and Figure 11								
		V _{CC} = 2.0 V	2	-11	-	2	-	2	-	ns
		V _{CC} = 4.5 V	2	-4	-	2	-	2	-	ns
		V _{CC} = 6.0 V	2	-3	-	2	-	2	-	ns
C _{PD}	power dissipation capacitance	f _i = 1 MHz; V _i = GND to V _{CC}	[4]	-	19	-	-	-	-	pF

74HCT259-Q100

t _{pd}	propagation delay	D to Qn; see Figure 6	[2]							
		V _{CC} = 4.5 V	-	23	39	-	49	-	59	ns
		V _{CC} = 5.0 V; C _L = 15 pF	-	20	-	-	-	-	-	ns
		An to Qn; see Figure 7	[2]							
		V _{CC} = 4.5 V	-	25	41	-	51	-	62	ns
		V _{CC} = 5.0 V; C _L = 15 pF	-	20	-	-	-	-	-	ns
		$\overline{\text{LE}}$ to Qn; see Figure 8	[2]							
		V _{CC} = 4.5 V	-	22	38	-	48	-	57	ns
		V _{CC} = 5.0 V; C _L = 15 pF	-	20	-	-	-	-	ns	
t _{PHL}	HIGH to LOW propagation delay	$\overline{\text{MR}}$ to Qn; see Figure 9								
		V _{CC} = 4.5 V	-	23	39	-	49	-	59	ns
		V _{CC} = 5.0 V; C _L = 15 pF	-	20	-	-	-	-	ns	
t _t	transition time	see Figure 8	[3]							
		V _{CC} = 4.5 V	-	7	15	-	19	-	22	ns
t _w	pulse width	$\overline{\text{LE}}$ HIGH or LOW; see Figure 8								
		V _{CC} = 4.5 V	19	11	-	24	-	29	-	ns
		$\overline{\text{MR}}$ LOW; see Figure 9								
		V _{CC} = 4.5 V	18	10	-	23	-	27	-	ns

Table 8. Dynamic characteristics ...continued

Voltages are referenced to GND (ground = 0 V); for test circuit see [Figure 12](#).

Symbol	Parameter	Conditions	25 °C			-40 °C to +85 °C		-40 °C to +125 °C		Unit	
			Min	Typ ^[1]	Max	Min	Max	Min	Max		
t _{su}	set-up time	D, An to \overline{LE} ; see Figure 10 and Figure 11 V _{CC} = 4.5 V	17	10	-	21	-	26	-	ns	
t _h	hold time	D to \overline{LE} ; see Figure 10 and Figure 11 V _{CC} = 4.5 V	0	-8	-	0	-	0	-	ns	
C _{PD}	power dissipation capacitance	f _i = 1 MHz; V _I = GND to V _{CC} - 1.5 V	[4]	-	19	-	-	-	-	pF	

[1] Typical values are measured at nominal supply voltage (V_{CC} = 3.3 V and V_{CC} = 5.0 V).

[2] t_{pd} is the same as t_{PLH} and t_{PHL}.

[3] t_i is the same as t_{THL} and t_{TLH}.

[4] C_{PD} is used to determine the dynamic power dissipation (P_D in μW).

$$P_D = C_{PD} \times V_{CC}^2 \times f_i \times N + \Sigma(C_L \times V_{CC}^2 \times f_o) \text{ where:}$$

f_i = input frequency in MHz;

f_o = output frequency in MHz;

C_L = output load capacitance in pF;

V_{CC} = supply voltage in V;

N = number of inputs switching;

Σ(C_L × V_{CC}² × f_o) = sum of the outputs.

11. Waveforms

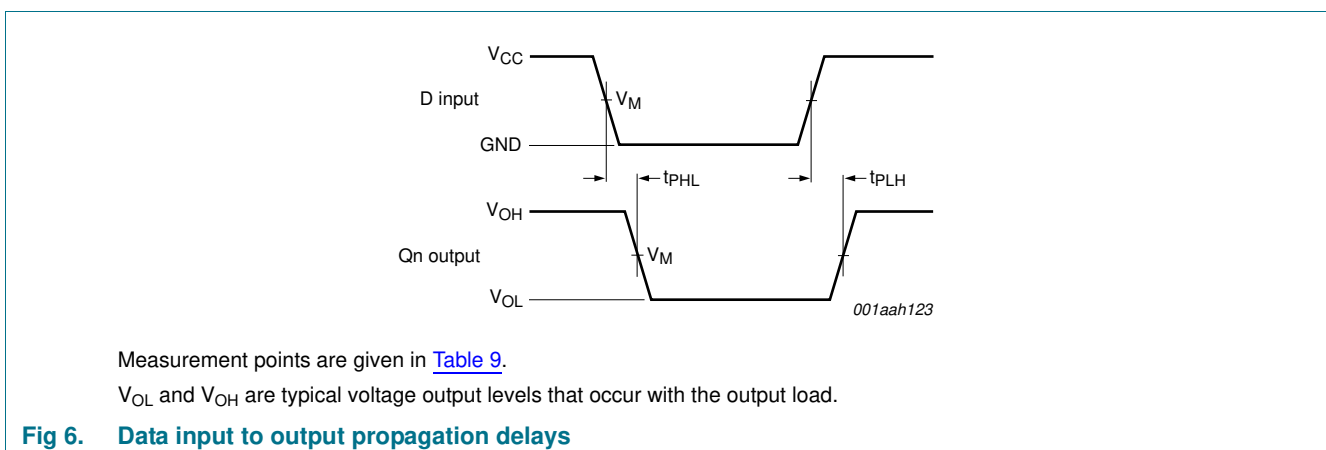

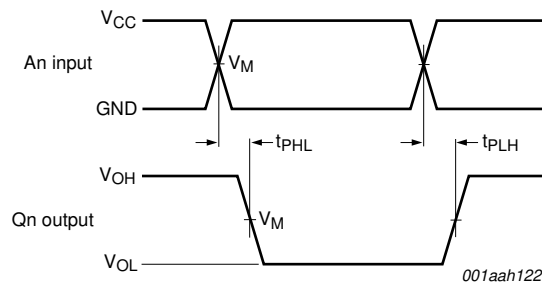

Measurement points are given in [Table 9](#).
 V_{OL} and V_{OH} are typical voltage output levels that occur with the output load.

Fig 7. Address input to output propagation delays

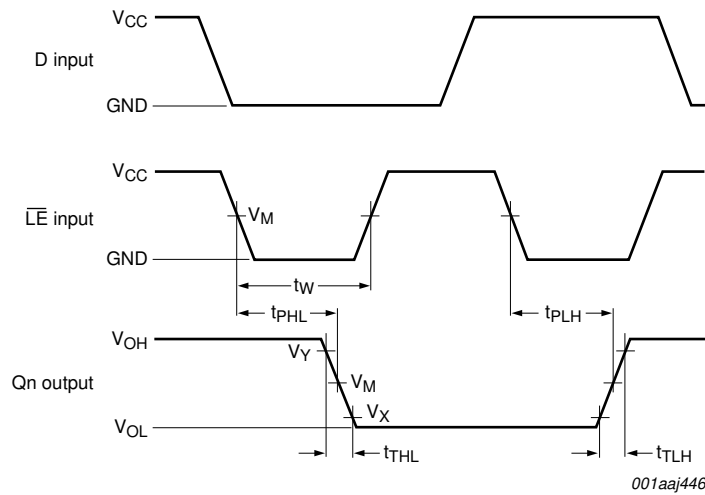

Measurement points are given in [Table 9](#).
 V_{OL} and V_{OH} are typical voltage output levels that occur with the output load.

Fig 8. Enable input to output propagation delays and pulse width

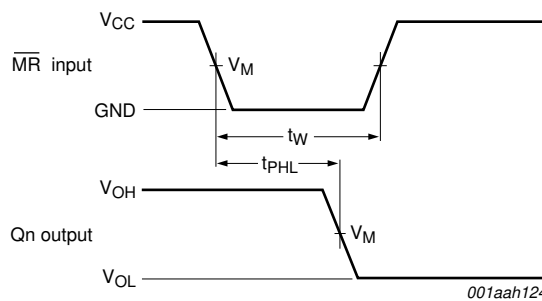

Measurement points are given in [Table 9](#).
 V_{OL} and V_{OH} are typical voltage output levels that occur with the output load.

Fig 9. Master reset input to output propagation delays

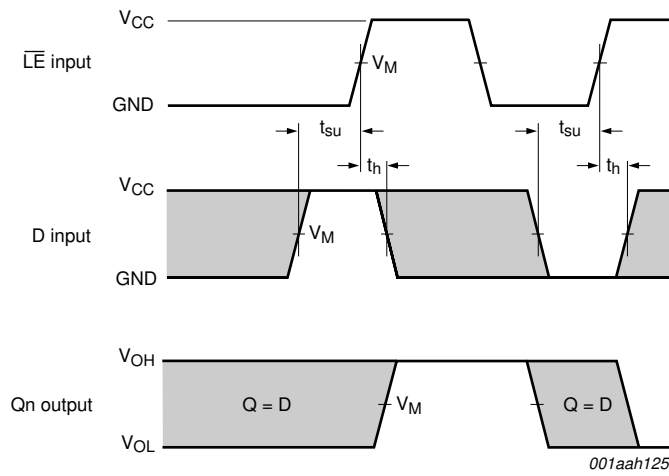

Measurement points are given in [Table 9](#).
 The shaded areas indicate when the input is permitted to change for predictable output performance.
 V_{OL} and V_{OH} are typical voltage output levels that occur with the output load.

Fig 10. Data input to latch enable input set-up and hold times

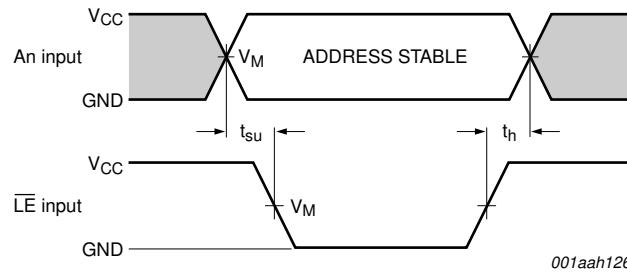

Measurement points are given in [Table 9](#).
 The shaded areas indicate when the input is permitted to change for predictable output performance.
 V_{OL} and V_{OH} are typical voltage output levels that occur with the output load.

Fig 11. Address input to latch enable input set-up and hold times

Table 9. Measurement points

Type	Input	Output		
	V_M	V_M	V_X	V_Y
74HC259-Q100	$0.5V_{CC}$	$0.5V_{CC}$	$0.1V_{CC}$	$0.9V_{CC}$
74HCT259-Q100	1.3 V	1.3 V	$0.1V_{CC}$	$0.9V_{CC}$

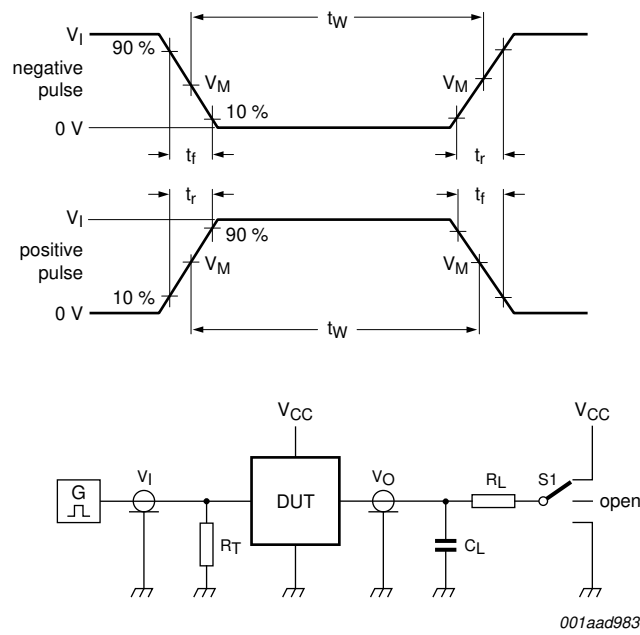

001aad983

Test data is given in [Table 10](#).

Definitions test circuit:

R_T = Termination resistance should be equal to output impedance Z_o of the pulse generator.

C_L = Load capacitance including jig and probe capacitance.

R_L = Load resistance.

S1 = Test selection switch

Fig 12. Load circuit for measuring switching times

Table 10. Test data

Type	Input		Load			S1 position
	V_I	t_r, t_f	C_L	R_L	t_{PHL}, t_{PLH}	
74HC259-Q100	V_{CC}	6 ns	15 pF, 50 pF	1 k Ω	open	
74HCT259-Q100	3 V	6 ns	15 pF, 50 pF	1 k Ω	open	

12. Package outline

SO16: plastic small outline package; 16 leads; body width 3.9 mm

SOT109-1

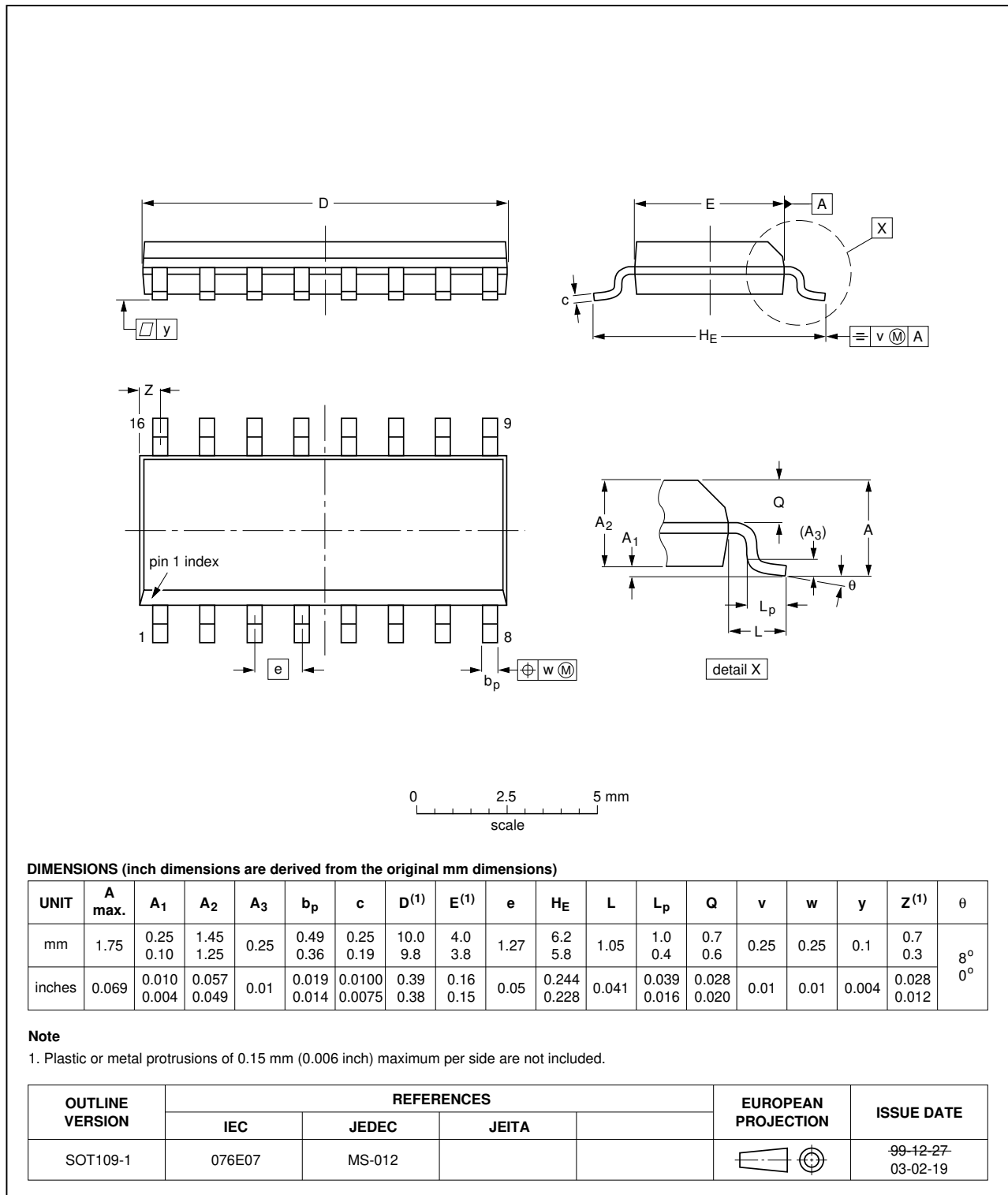

Fig 13. Package outline SOT109-1 (SO16)

TSSOP16: plastic thin shrink small outline package; 16 leads; body width 4.4 mm

SOT403-1

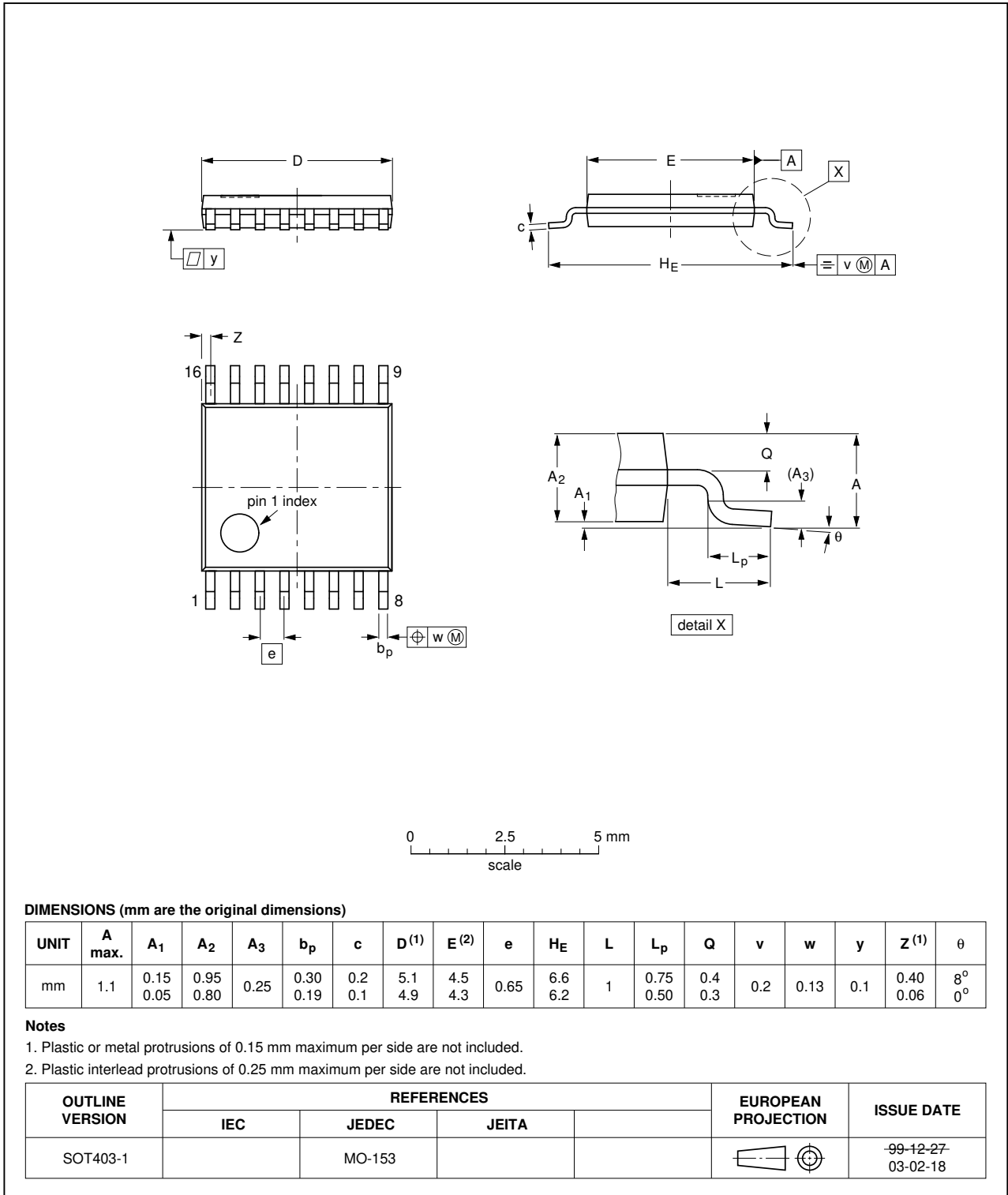

Fig 14. Package outline SOT403-1 (TSSOP16)

DHVQFN16: plastic dual in-line compatible thermal enhanced very thin quad flat package; no leads; 16 terminals; body 2.5 x 3.5 x 0.85 mm

SOT763-1

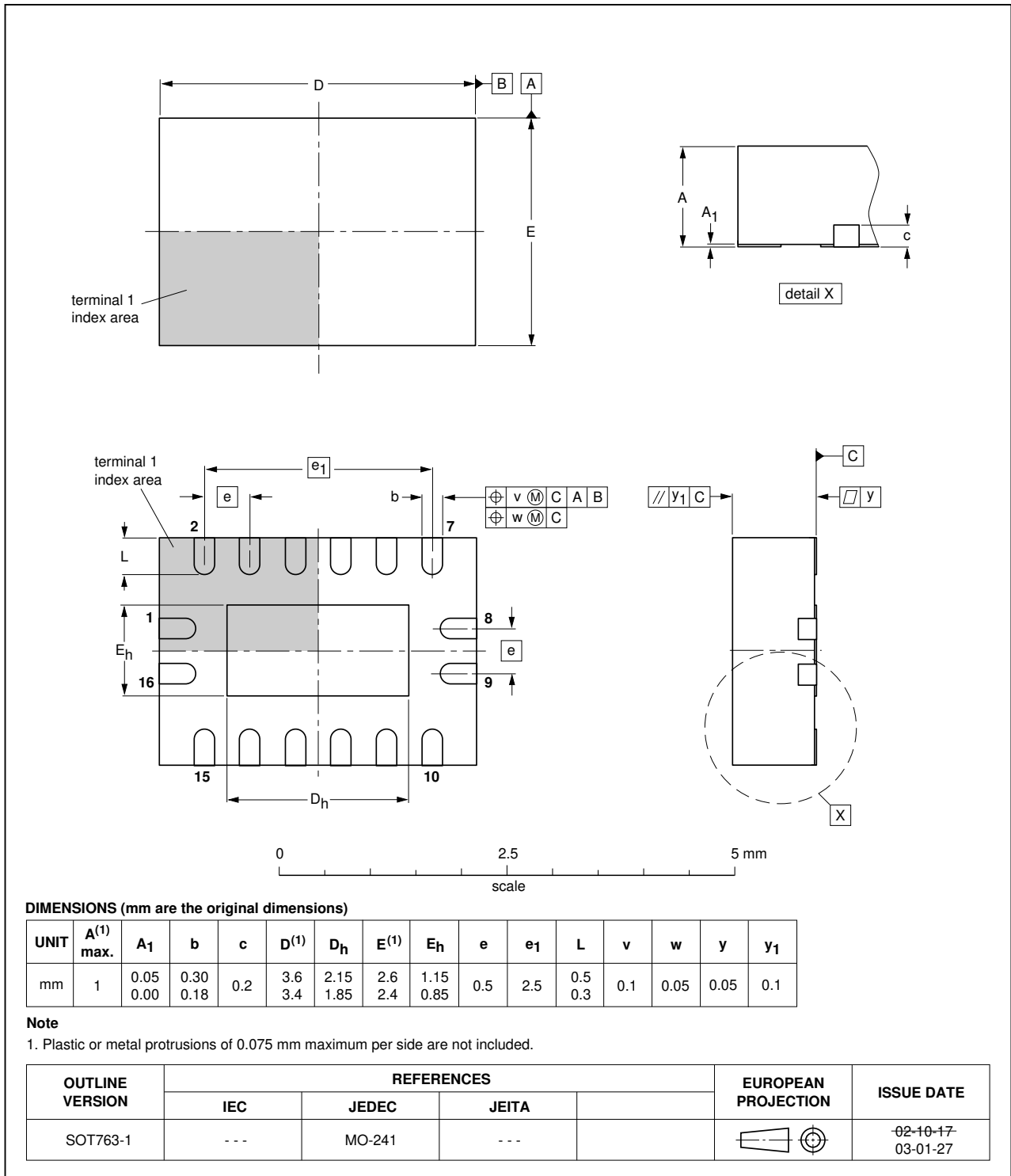

Fig 15. Package outline SOT763-1 (DHVQFN16)

13. Abbreviations

Table 11. Abbreviations

Acronym	Description
CDM	Charged Device Model
CMOS	Complementary Metal-Oxide Semiconductor
DUT	Device Under Test
ESD	ElectroStatic Discharge
HBM	Human Body Model
LSTTL	Low-power Schottky Transistor-Transistor Logic
MM	Machine Model
TTL	Transistor-Transistor Logic

14. Revision history

Table 12. Revision history

Document ID	Release date	Data sheet status	Change notice	Supersedes
74HC_HCT259_Q100 v.1	20120730	Product data sheet	-	-

15. Legal information

15.1 Data sheet status

Document status ^{[1][2]}	Product status ^[3]	Definition
Objective [short] data sheet	Development	This document contains data from the objective specification for product development.
Preliminary [short] data sheet	Qualification	This document contains data from the preliminary specification.
Product [short] data sheet	Production	This document contains the product specification.

[1] Please consult the most recently issued document before initiating or completing a design.

[2] The term 'short data sheet' is explained in section "Definitions".

[3] The product status of device(s) described in this document may have changed since this document was published and may differ in case of multiple devices. The latest product status information is available on the Internet at URL <http://www.nxp.com>.

15.2 Definitions

Draft — The document is a draft version only. The content is still under internal review and subject to formal approval, which may result in modifications or additions. NXP Semiconductors does not give any representations or warranties as to the accuracy or completeness of information included herein and shall have no liability for the consequences of use of such information.

Short data sheet — A short data sheet is an extract from a full data sheet with the same product type number(s) and title. A short data sheet is intended for quick reference only and should not be relied upon to contain detailed and full information. For detailed and full information see the relevant full data sheet, which is available on request via the local NXP Semiconductors sales office. In case of any inconsistency or conflict with the short data sheet, the full data sheet shall prevail.

Product specification — The information and data provided in a Product data sheet shall define the specification of the product as agreed between NXP Semiconductors and its customer, unless NXP Semiconductors and customer have explicitly agreed otherwise in writing. In no event however, shall an agreement be valid in which the NXP Semiconductors product is deemed to offer functions and qualities beyond those described in the Product data sheet.

15.3 Disclaimers

Limited warranty and liability — Information in this document is believed to be accurate and reliable. However, NXP Semiconductors does not give any representations or warranties, expressed or implied, as to the accuracy or completeness of such information and shall have no liability for the consequences of use of such information. NXP Semiconductors takes no responsibility for the content in this document if provided by an information source outside of NXP Semiconductors.

In no event shall NXP Semiconductors be liable for any indirect, incidental, punitive, special or consequential damages (including - without limitation - lost profits, lost savings, business interruption, costs related to the removal or replacement of any products or rework charges) whether or not such damages are based on tort (including negligence), warranty, breach of contract or any other legal theory.

Notwithstanding any damages that customer might incur for any reason whatsoever, NXP Semiconductors' aggregate and cumulative liability towards customer for the products described herein shall be limited in accordance with the *Terms and conditions of commercial sale* of NXP Semiconductors.

Right to make changes — NXP Semiconductors reserves the right to make changes to information published in this document, including without limitation specifications and product descriptions, at any time and without notice. This document supersedes and replaces all information supplied prior to the publication hereof.

Suitability for use in automotive applications — This NXP Semiconductors product has been qualified for use in automotive applications. Unless otherwise agreed in writing, the product is not designed, authorized or warranted to be suitable for use in life support, life-critical or safety-critical systems or equipment, nor in applications where failure or malfunction of an NXP Semiconductors product can reasonably be expected to result in personal injury, death or severe property or environmental damage. NXP Semiconductors and its suppliers accept no liability for inclusion and/or use of NXP Semiconductors products in such equipment or applications and therefore such inclusion and/or use is at the customer's own risk.

Applications — Applications that are described herein for any of these products are for illustrative purposes only. NXP Semiconductors makes no representation or warranty that such applications will be suitable for the specified use without further testing or modification.

Customers are responsible for the design and operation of their applications and products using NXP Semiconductors products, and NXP Semiconductors accepts no liability for any assistance with applications or customer product design. It is customer's sole responsibility to determine whether the NXP Semiconductors product is suitable and fit for the customer's applications and products planned, as well as for the planned application and use of customer's third party customer(s). Customers should provide appropriate design and operating safeguards to minimize the risks associated with their applications and products.

NXP Semiconductors does not accept any liability related to any default, damage, costs or problem which is based on any weakness or default in the customer's applications or products, or the application or use by customer's third party customer(s). Customer is responsible for doing all necessary testing for the customer's applications and products using NXP Semiconductors products in order to avoid a default of the applications and the products or of the application or use by customer's third party customer(s). NXP does not accept any liability in this respect.

Limiting values — Stress above one or more limiting values (as defined in the Absolute Maximum Ratings System of IEC 60134) will cause permanent damage to the device. Limiting values are stress ratings only and (proper) operation of the device at these or any other conditions above those given in the Recommended operating conditions section (if present) or the Characteristics sections of this document is not warranted. Constant or repeated exposure to limiting values will permanently and irreversibly affect the quality and reliability of the device.

Terms and conditions of commercial sale — NXP Semiconductors products are sold subject to the general terms and conditions of commercial sale, as published at <http://www.nxp.com/profile/terms>, unless otherwise agreed in a valid written individual agreement. In case an individual agreement is concluded only the terms and conditions of the respective agreement shall apply. NXP Semiconductors hereby expressly objects to applying the customer's general terms and conditions with regard to the purchase of NXP Semiconductors products by customer.

No offer to sell or license — Nothing in this document may be interpreted or construed as an offer to sell products that is open for acceptance or the grant, conveyance or implication of any license under any copyrights, patents or other industrial or intellectual property rights.

Export control — This document as well as the item(s) described herein may be subject to export control regulations. Export might require a prior authorization from competent authorities.

Translations — A non-English (translated) version of a document is for reference only. The English version shall prevail in case of any discrepancy between the translated and English versions.

15.4 Trademarks

Notice: All referenced brands, product names, service names and trademarks are the property of their respective owners.

16. Contact information

For more information, please visit: <http://www.nxp.com>

For sales office addresses, please send an email to: salesaddresses@nxp.com

17. Contents

1	General description	1
2	Features and benefits	1
3	Ordering information	2
4	Functional diagram	2
5	Pinning information	3
5.1	Pinning	3
5.2	Pin description	4
6	Functional description	4
7	Limiting values	5
8	Recommended operating conditions	6
9	Static characteristics	6
10	Dynamic characteristics	8
11	Waveforms	10
12	Package outline	14
13	Abbreviations	17
14	Revision history	17
15	Legal information	18
15.1	Data sheet status	18
15.2	Definitions	18
15.3	Disclaimers	18
15.4	Trademarks	19
16	Contact information	19
17	Contents	20

Please be aware that important notices concerning this document and the product(s) described herein, have been included in section 'Legal information'.

© NXP B.V. 2012.

All rights reserved.

For more information, please visit: <http://www.nxp.com>

For sales office addresses, please send an email to: salesaddresses@nxp.com

Date of release: 30 July 2012

Document identifier: 74HC_HCT259_Q100