



Chipsmall Limited consists of a professional team with an average of over 10 year of expertise in the distribution of electronic components. Based in Hongkong, we have already established firm and mutual-benefit business relationships with customers from,Europe,America and south Asia,supplying obsolete and hard-to-find components to meet their specific needs.

With the principle of “Quality Parts,Customers Priority,Honest Operation,and Considerate Service”,our business mainly focus on the distribution of electronic components. Line cards we deal with include Microchip,ALPS,ROHM,Xilinx,Pulse,ON,Everlight and Freescale. Main products comprise IC,Modules,Potentiometer,IC Socket,Relay,Connector.Our parts cover such applications as commercial,industrial, and automotives areas.

We are looking forward to setting up business relationship with you and hope to provide you with the best service and solution. Let us make a better world for our industry!



Contact us

Tel: +86-755-8981 8866 Fax: +86-755-8427 6832

Email & Skype: info@chipsmall.com Web: www.chipsmall.com

Address: A1208, Overseas Decoration Building, #122 Zhenhua RD., Futian, Shenzhen, China



DATA SHEET

For a complete data sheet, please also download:

- The IC06 74HC/HCT/HCU/HCMOS Logic Family Specifications
- The IC06 74HC/HCT/HCU/HCMOS Logic Package Information
- The IC06 74HC/HCT/HCU/HCMOS Logic Package Outlines

74HC/HCT390 Dual decade ripple counter

Product specification
File under Integrated Circuits, IC06

December 1990

Dual decade ripple counter

74HC/HCT390

FEATURES

- Two BCD decade or bi-quinary counters
- One package can be configured to divide-by-2, 4, 5, 10, 20, 25, 50 or 100
- Two master reset inputs to clear each decade counter individually
- Output capability: standard
- I_{CC} category: MSI

GENERAL DESCRIPTION

The 74HC/HCT390 are high-speed Si-gate CMOS devices and are pin compatible with low power Schottky TTL (LSTTL). They are specified in compliance with JEDEC standard no. 7A.

The 74HC/HCT390 are dual 4-bit decade ripple counters divided into four separately clocked sections. The counters have two divide-by-2 sections and two divide-by-5 sections. These sections are normally used in a BCD

decade or bi-quinary configuration, since they share a common master reset input (nMR). If the two master reset inputs (1MR and 2MR) are used to simultaneously clear all 8 bits of the counter, a number of counting configurations are possible within one package. The separate clocks (nCP₀ and nCP₁) of each section allow ripple counter or frequency division applications of divide-by-2, 4, 5, 10, 20, 25, 50 or 100.

Each section is triggered by the HIGH-to-LOW transition of the clock inputs (nCP₀ and nCP₁). For BCD decade operation, the nQ₀ output is connected to the nCP₁ input of the divide-by-5 section. For bi-quinary decade operation, the nQ₃ output is connected to the nCP₀ input and nQ₀ becomes the decade output.

The master reset inputs (1MR and 2MR) are active HIGH asynchronous inputs to each decade counter which operates on the portion of the counter identified by the "1" and "2" prefixes in the pin configuration. A HIGH level on the nMR input overrides the clocks and sets the four outputs LOW.

QUICK REFERENCE DATA

GND = 0 V; T_{amb} = 25 °C; t_r = t_f = 6 ns

SYMBOL	PARAMETER	CONDITIONS	TYPICAL		UNIT
			HC	HCT	
t _{PHL} / t _{PLH}	propagation delay nCP ₀ to nQ ₀ nCP ₁ to nQ ₁ nCP ₁ to nQ ₂ nCP ₁ to nQ ₃ nMR to Q _n	C _L = 15 pF; V _{CC} = 5 V	14	18	ns
			15	19	ns
			23	26	ns
			15	19	ns
			16	18	ns
f _{max}	maximum clock frequency nCP ₀ , nCP ₁		66	61	MHz
C _I	input capacitance		3.5	3.5	pF
C _{PD}	power dissipation capacitance per counter	notes 1 and 2	20	21	pF

Notes

1. C_{PD} is used to determine the dynamic power dissipation (P_D in μW):

$$P_D = C_{PD} \times V_{CC}^2 \times f_i + \sum (C_L \times V_{CC}^2 \times f_o) \text{ where:}$$

f_i = input frequency in MHz

f_o = output frequency in MHz

∑ (C_L × V_{CC}² × f_o) = sum of outputs

C_L = output load capacitance in pF

V_{CC} = supply voltage in V

2. For HC the condition is V_I = GND to V_{CC}
For HCT the condition is V_I = GND to V_{CC} -1.5 V

Dual decade ripple counter

74HC/HCT390

ORDERING INFORMATION

See “74HC/HCT/HCU/HCMOS Logic Package Information”.

PIN DESCRIPTION

PIN NO.	SYMBOL	NAME AND FUNCTION
1, 15	$1\overline{CP}_0, 2\overline{CP}_0$	clock input divide-by-2 section (HIGH-to-LOW, edge-triggered)
2, 14	1MR, 2MR	asynchronous master reset inputs (active HIGH)
3, 5, 6, 7	1Q ₀ to 1Q ₃	flip-flop outputs
4, 12	$1\overline{CP}_1, 2\overline{CP}_1$	clock input divide-by-5 section (HIGH-to-LOW, edge triggered)
8	GND	ground (0 V)
13, 11, 10, 9	2Q ₀ to 2Q ₃	flip-flop outputs
16	V _{CC}	positive supply voltage

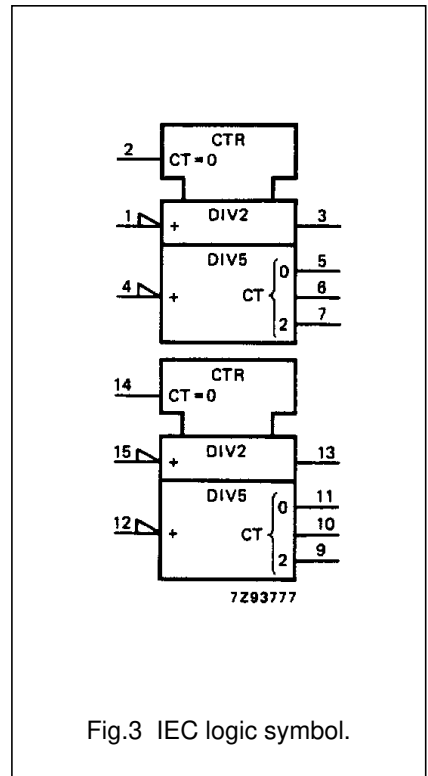
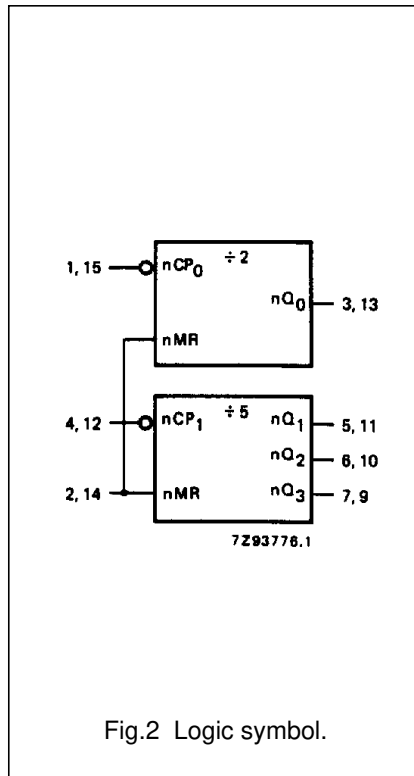
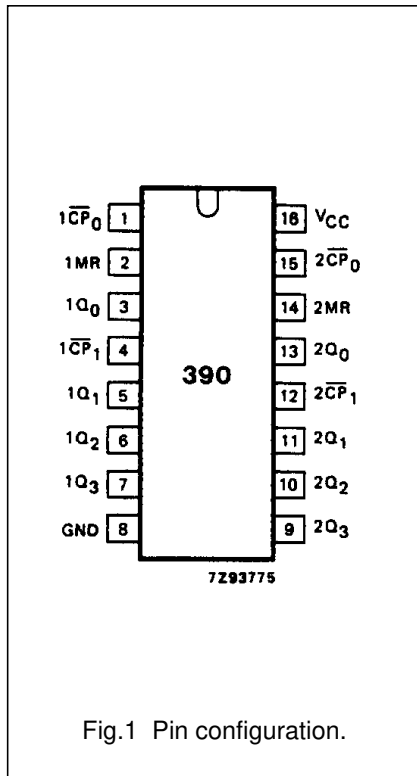

Dual decade ripple counter

74HC/HCT390

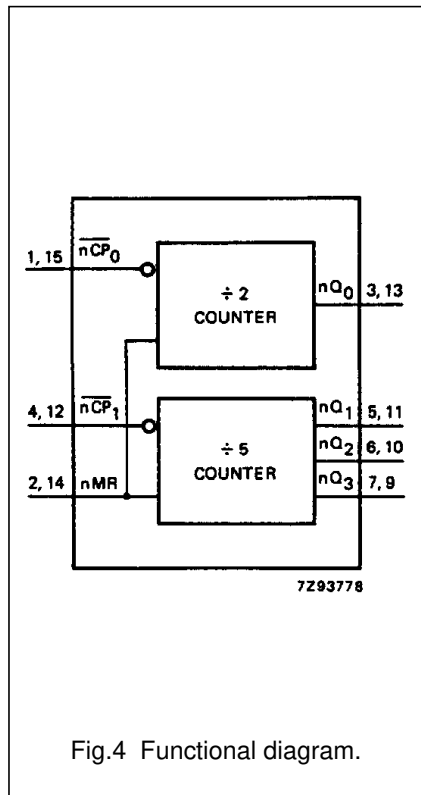

Fig.4 Functional diagram.

BCD COUNT SEQUENCE FOR 1/2 THE "390"

COUNT	OUTPUTS			
	Q ₀	Q ₁	Q ₂	Q ₃
0	L	L	L	L
1	H	L	L	L
2	L	H	L	L
3	H	H	L	L
4	L	L	H	L
5	H	L	H	L
6	L	H	H	L
7	H	H	H	L
8	L	L	L	H
9	H	L	L	H

Notes

1. Output Q₀ connected to $\overline{nCP_1}$ with counter input on $\overline{nCP_0}$.
H = HIGH voltage level
L = LOW voltage level

BI-QUINARY COUNT SEQUENCE FOR 1/2 THE "390"

COUNT	OUTPUTS			
	Q ₀	Q ₁	Q ₂	Q ₃
0	L	L	L	L
1	L	H	L	L
2	L	L	H	L
3	L	H	H	L
4	L	L	L	H
5	H	L	L	L
6	H	H	L	L
7	H	L	H	L
8	H	H	H	L
9	H	L	L	H

Note

1. Output Q₃ connected to $\overline{nCP_0}$ with counter input on $\overline{nCP_1}$.

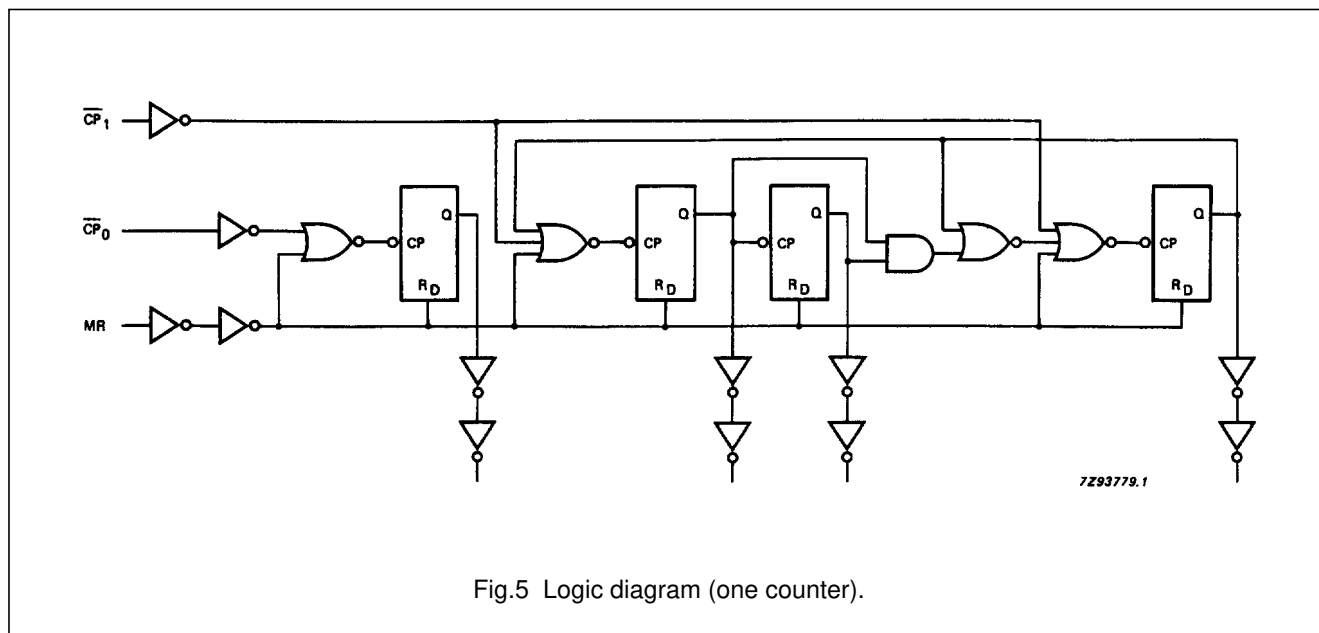

Fig.5 Logic diagram (one counter).

Dual decade ripple counter

74HC/HCT390

DC CHARACTERISTICS FOR 74HC

For the DC characteristics see *"74HC/HCT/HCU/HCMOS Logic Family Specifications"*.

Output capability: standard

I_{CC} category: MSI

AC CHARACTERISTICS FOR 74HC

GND = 0 V; t_r = t_f = 6 ns; C_L = 50 pF

SYMBOL	PARAMETER	T _{amb} (°C)						UNIT	TEST CONDITIONS		
		74HC							V _{CC} (V)	WAVEFORMS	
		+25			-40 to +85		-40 to +125				
		min.	typ.	max.	min.	max.	min.				max.
t _{PHL} / t _{PLH}	propagation delay nCP ₀ to nQ ₀		47 17 14	145 29 25		180 36 31		220 44 38	ns	2.0 4.5 6.0	Fig.6
t _{PHL} / t _{PLH}	propagation delay nCP ₁ to nQ ₁		50 18 14	155 31 26		195 39 33		235 47 40	ns	2.0 4.5 6.0	Fig.6
t _{PHL} / t _{PLH}	propagation delay nCP ₁ to nQ ₂		74 27 22	210 42 36		265 53 45		315 63 54	ns	2.0 4.5 6.0	Fig.6
t _{PHL} / t _{PLH}	propagation delay nCP ₁ to nQ ₃		50 18 14	155 31 26		195 39 33		235 47 40	ns	2.0 4.5 6.0	Fig.6
t _{PHL}	propagation delay nMR to nQ _n		52 19 15	165 33 28		205 41 35		250 50 43	ns	2.0 4.5 6.0	Fig.7
t _{THL} / t _{TLH}	output transition time		19 7 6	75 15 13		95 19 16		110 22 19	ns	2.0 4.5 6.0	Fig.6
t _w	clock pulse width nCP ₀ , nCP ₁	80 16 14	19 7 6		100 20 17		120 24 20		ns	2.0 4.5 6.0	Fig.6
t _w	master reset pulse width HIGH	80 17 14	28 10 8		105 21 18		130 26 22		ns	2.0 4.5 6.0	Fig.7
t _{rem}	removal time nMR to nCP _n	75 15 13	22 8 6		95 19 16		110 22 19		ns	2.0 4.5 6.0	Fig.7
f _{max}	maximum clock pulse frequency nCP ₀ , nCP ₁	6.0 30 35	20 60 71		4.8 24 28		4.0 20 24		MHz	2.0 4.5 6.0	Fig.6

Dual decade ripple counter

74HC/HCT390

DC CHARACTERISTICS FOR 74HCT

For the DC characteristics see *"74HC/HCT/HCU/HCMOS Logic Family Specifications"*.

Output capability: standard

I_{CC} category: MSI

Note to HCT types

The value of additional quiescent supply current (ΔI_{CC}) for a unit load of 1 is given in the family specifications. To determine ΔI_{CC} per input, multiply this value by the unit load coefficient shown in the table below.

INPUT	UNIT LOAD COEFFICIENT
$\overline{nCP_0}$	0.45
$\overline{nCP_1}$, nMR	0.60

AC CHARACTERISTICS FOR 74HCT

GND = 0 V; $t_r = t_f = 6$ ns; $C_L = 50$ pF

SYMBOL	PARAMETER	T _{amb} (°C)								UNIT	TEST CONDITIONS	
		74HCT									V _{CC} (V)	WAVEFORMS
		+25			-40 to +85		-40 to +125					
		min.	typ.	max.	min.	max.	min.	max.				
t _{PHL} / t _{PLH}	propagation delay nCP ₀ to nQ ₀		21	34		43		51	ns	4.5	Fig.6	
t _{PHL} / t _{PLH}	propagation delay nCP ₁ to nQ ₁		22	38		48		57	ns	4.5	Fig.6	
t _{PHL} / t _{PLH}	propagation delay nCP ₁ to nQ ₂		30	51		64		77	ns	4.5	Fig.6	
t _{PHL} / t _{PLH}	propagation delay nCP ₁ to nQ ₃		22	38		48		57	ns	4.5	Fig.6	
t _{PHL}	propagation delay nMR to nQ _n		21	36		45		54	ns	4.5	Fig.7	
t _{THL} / t _{TLH}	output transition time		7	15		19		22	ns	4.5	Fig.6	
t _w	clock pulse width nCP ₀ , nCP ₁	18	8		23		27		ns	4.5	Fig.6	
t _w	master reset pulse width HIGH	17	10		21		26		ns	4.5	Fig.7	
t _{rem}	removal time nMR to nCP _n	15	8		19		22		ns	4.5	Fig.7	
f _{max}	maximum clock pulse frequency nCP ₀ , nCP ₁	27	55		22		18		MHz	4.5	Fig.6	

Dual decade ripple counter

74HC/HCT390

AC WAVEFORMS

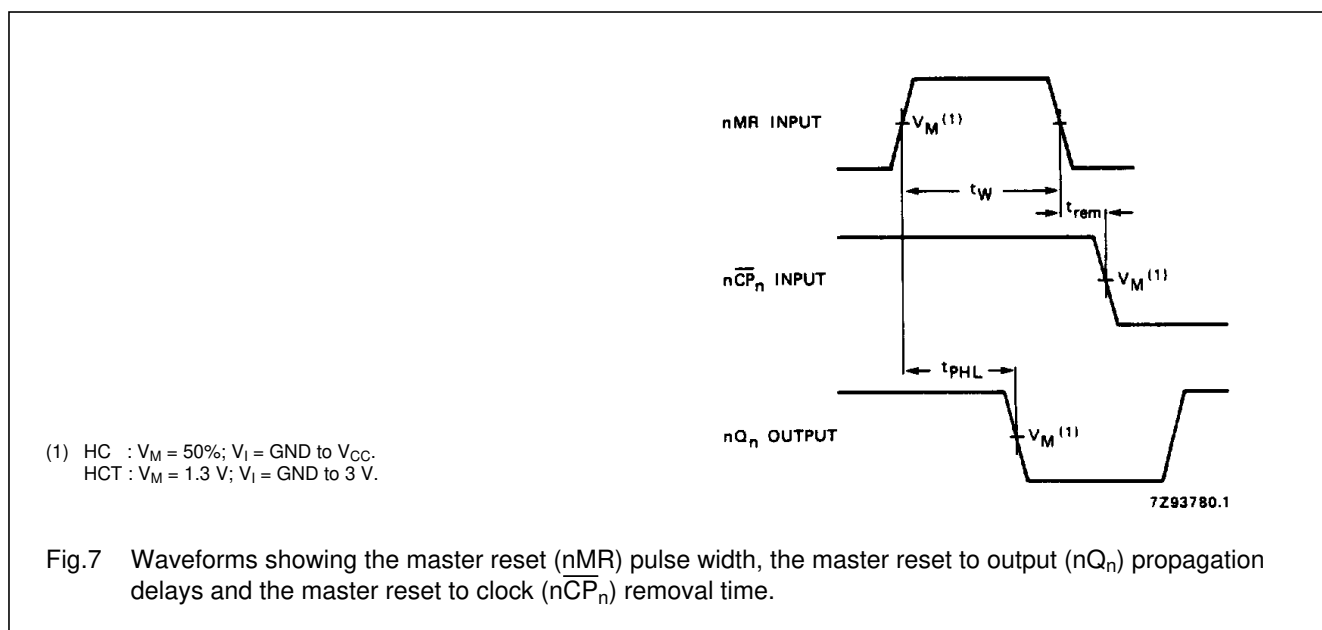
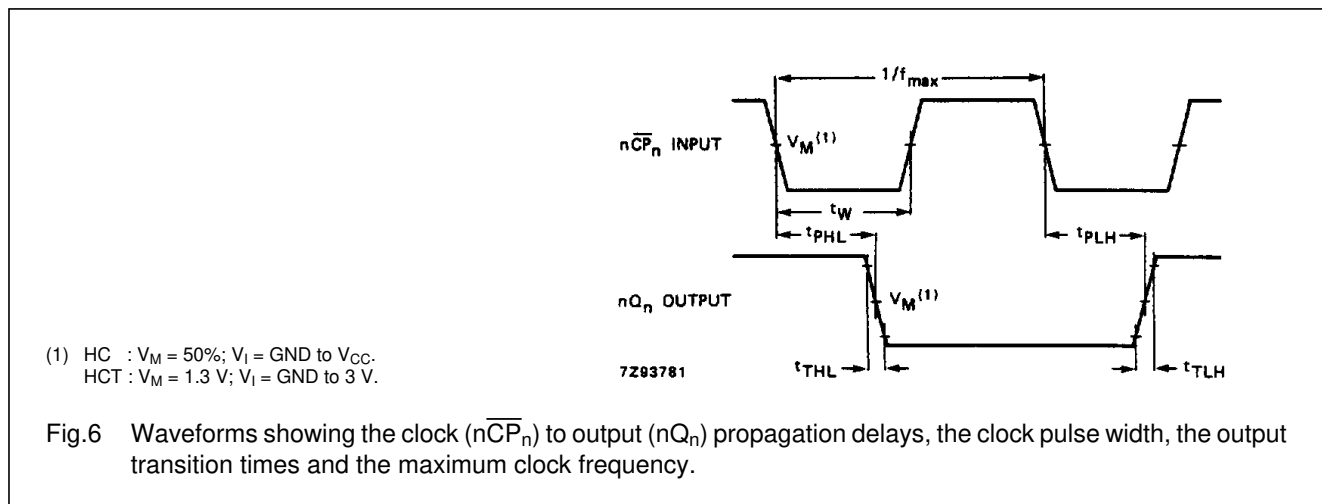

PACKAGE OUTLINES

See "74HC/HCT/HCU/HCMOS Logic Package Outlines".