



Chipsmall Limited consists of a professional team with an average of over 10 year of expertise in the distribution of electronic components. Based in Hongkong, we have already established firm and mutual-benefit business relationships with customers from,Europe,America and south Asia,supplying obsolete and hard-to-find components to meet their specific needs.

With the principle of “Quality Parts,Customers Priority,Honest Operation,and Considerate Service”,our business mainly focus on the distribution of electronic components. Line cards we deal with include Microchip,ALPS,ROHM,Xilinx,Pulse,ON,Everlight and Freescale. Main products comprise IC,Modules,Potentiometer,IC Socket,Relay,Connector.Our parts cover such applications as commercial,industrial, and automotives areas.

We are looking forward to setting up business relationship with you and hope to provide you with the best service and solution. Let us make a better world for our industry!



## Contact us

Tel: +86-755-8981 8866 Fax: +86-755-8427 6832

Email & Skype: info@chipsmall.com Web: www.chipsmall.com

Address: A1208, Overseas Decoration Building, #122 Zhenhua RD., Futian, Shenzhen, China



## Important notice

Dear Customer,

On 7 February 2017 the former NXP Standard Product business became a new company with the tradename **Nexperia**. Nexperia is an industry leading supplier of Discrete, Logic and PowerMOS semiconductors with its focus on the automotive, industrial, computing, consumer and wearable application markets

In data sheets and application notes which still contain NXP or Philips Semiconductors references, use the references to Nexperia, as shown below.

Instead of <http://www.nxp.com>, <http://www.philips.com/> or <http://www.semiconductors.philips.com/>, use <http://www.nexperia.com>

Instead of [sales.addresses@www.nxp.com](mailto:sales.addresses@www.nxp.com) or [sales.addresses@www.semiconductors.philips.com](mailto:sales.addresses@www.semiconductors.philips.com), use [salesaddresses@nexperia.com](mailto:salesaddresses@nexperia.com) (email)

Replace the copyright notice at the bottom of each page or elsewhere in the document, depending on the version, as shown below:

- © NXP N.V. (year). All rights reserved or © Koninklijke Philips Electronics N.V. (year). All rights reserved

Should be replaced with:

- © **Nexperia B.V. (year). All rights reserved.**

If you have any questions related to the data sheet, please contact our nearest sales office via e-mail or telephone (details via [salesaddresses@nexperia.com](mailto:salesaddresses@nexperia.com)). Thank you for your cooperation and understanding,

Kind regards,

Team Nexperia

# 74HC1G66-Q100; 74HCT1G66-Q100

Single-pole single-throw analog switch

Rev. 1 — 16 September 2013

Product data sheet

## 1. General description

The 74HC1G66-Q100; 74HCT1G66-Q100 is a single-pole, single-throw analog switch with two input/output terminals (nY and nZ) and a digital enable input (nE). When nE is LOW, the analog switch is turned off. Inputs include clamp diodes that enable the use of current limiting resistors to interface inputs to voltages in excess of  $V_{CC}$ .

This product has been qualified to the Automotive Electronics Council (AEC) standard Q100 (Grade 1) and is suitable for use in automotive applications.

## 2. Features and benefits

- Automotive product qualification in accordance with AEC-Q100 (Grade 1)
  - ◆ Specified from  $-40\text{ °C}$  to  $+85\text{ °C}$  and from  $-40\text{ °C}$  to  $+125\text{ °C}$
- Wide supply voltage range from 2.0 V to 10.0 V for the 74HC1G66-Q100
- Very low ON resistance:
  - ◆  $45\ \Omega$  (typ.) at  $V_{CC} = 4.5\text{ V}$
  - ◆  $30\ \Omega$  (typ.) at  $V_{CC} = 6.0\text{ V}$
  - ◆  $25\ \Omega$  (typ.) at  $V_{CC} = 9.0\text{ V}$
- High noise immunity
- Low power dissipation
- Multiple package options
- ESD protection:
  - ◆ MIL-STD-883, method 3015 exceeds 2000 V
  - ◆ HBM JESD22-A114F exceeds 2000 V
  - ◆ MM JESD22-A115-A exceeds 200 V ( $C = 200\text{ pf}$ ,  $R = 0\ \Omega$ )

## 3. Ordering information

Table 1. Ordering information

Type number	Package			
	Temperature range	Name	Description	Version
74HC1G66GW-Q100 74HCT1G66GW-Q100	$-40\text{ °C}$ to $+125\text{ °C}$	TSSOP5	plastic thin shrink small outline package; 5 leads; body width 1.25 mm	SOT353-1
74HC1G66GV-Q100 74HCT1G66GV-Q100	$-40\text{ °C}$ to $+125\text{ °C}$	SC-74A	plastic surface-mounted package; 5 leads	SOT753



## 4. Marking

Table 2. Marking codes

Type number	Marking
74HC1G66GW-Q100	HL
74HCT1G66GW-Q100	TL
74HC1G66GV-Q100	H66
74HCT1G66GV-Q100	T66

## 5. Functional diagram

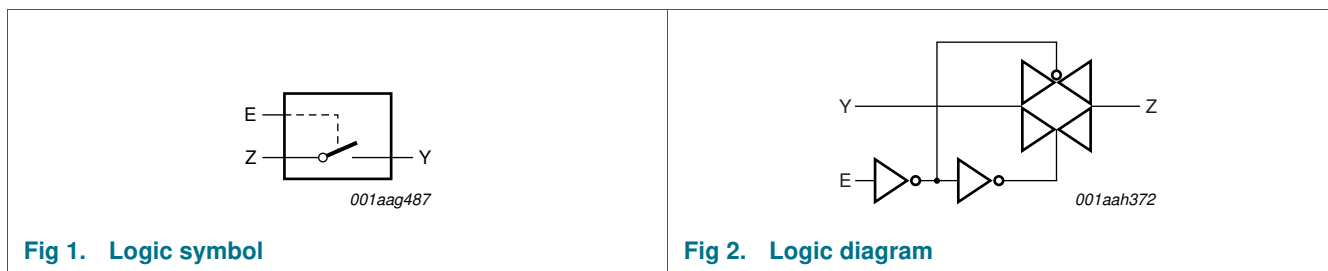

## 6. Pinning information

### 6.1 Pinning

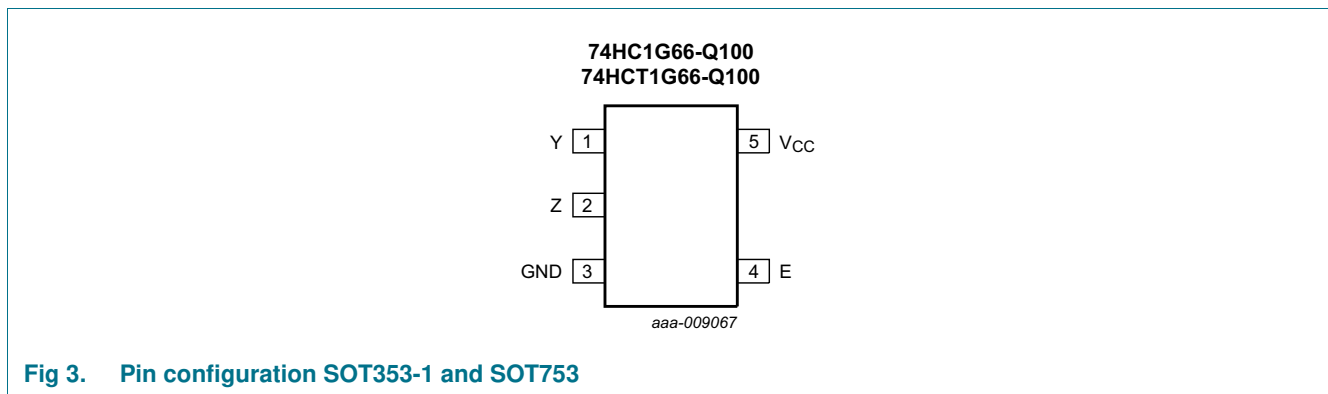

### 6.2 Pin description

Table 3. Pin description

Symbol	Pin	Description
Y	1	independent input or output
Z	2	independent input or output
GND	3	ground (0 V)
E	4	enable input (active HIGH)
V <sub>CC</sub>	5	supply voltage

## 7. Functional description

Table 4. Function table<sup>[1]</sup>

Input E	Switch
L	OFF
H	ON

[1] H = HIGH voltage level; L = LOW voltage level.

## 8. Limiting values

Table 5. Limiting values

In accordance with the Absolute Maximum Rating System (IEC 60134). Voltages are referenced to GND (ground = 0 V).

Symbol	Parameter	Conditions	Min	Max	Unit
$V_{CC}$	supply voltage		-0.5	+11.0	V
$I_{IK}$	input clamping current	$V_I < -0.5\text{ V}$ or $V_I > V_{CC} + 0.5\text{ V}$	[1] -	±20	mA
$I_{SK}$	switch clamping current	$V_I < -0.5\text{ V}$ or $V_I > V_{CC} + 0.5\text{ V}$	[1] -	±20	mA
$I_{SW}$	switch current	$V_{SW} > -0.5\text{ V}$ or $V_{SW} < V_{CC} + 0.5\text{ V}$	-	±25	mA
$I_{CC}$	supply current		-	50	mA
$I_{GND}$	ground current		-50	-	mA
$T_{stg}$	storage temperature		-65	+150	°C
$P_{tot}$	total power dissipation	$T_{amb} = -40\text{ °C}$ to $+125\text{ °C}$	[2] -	250	mW

[1] The input and output voltage ratings may be exceeded if the input and output current ratings are observed.

[2] For TSSOP5 and SC-74A packages: above 87.5 °C the value of  $P_{tot}$  derates linearly with 4.0 mW/K.

## 9. Recommended operating conditions

Table 6. Recommended operating conditions

Voltages are referenced to GND (ground = 0 V).<sup>[1]</sup>

Symbol	Parameter	Conditions	74HC1G66-Q100			74HCT1G66-Q100			Unit
			Min	Typ	Max	Min	Typ	Max	
$V_{CC}$	supply voltage		2.0	5.0	10.0	4.5	5.0	5.5	V
$V_I$	input voltage		0	-	$V_{CC}$	0	-	$V_{CC}$	V
$V_{SW}$	switch voltage		0	-	$V_{CC}$	0	-	$V_{CC}$	V
$T_{amb}$	ambient temperature		-40	+25	+125	-40	+25	+125	°C
$\Delta t/\Delta V$	input transition rise and fall rate	$V_{CC} = 2.0\text{ V}$	-	-	625	-	-	-	ns/V
		$V_{CC} = 4.5\text{ V}$	-	1.67	139	-	1.67	139	ns/V
		$V_{CC} = 6.0\text{ V}$	-	-	83	-	-	-	ns/V
		$V_{CC} = 10.0\text{ V}$	-	-	35	-	-	-	ns/V

[1] To avoid drawing  $V_{CC}$  current from pin Z, when switch current flows in pin Y, the voltage drop across the bidirectional switch must not exceed 0.4 V. If the switch current flows into pin Z, no  $V_{CC}$  current flows from terminal Y. In this case, the voltage drop across the switch is unlimited, but the voltage at pins Y and Z may not exceed  $V_{CC}$  or GND.

## 10. Static characteristics

**Table 7. Static characteristics**

Voltages are referenced to GND (ground = 0 V).

Symbol	Parameter	Conditions	-40 °C to +85 °C			-40 °C to +125 °C		Unit
			Min	Typ <sup>[1]</sup>	Max	Min	Max	
<b>74HC1G66-Q100</b>								
V <sub>IH</sub>	HIGH-level input voltage	V <sub>CC</sub> = 2.0 V	1.5	1.2	-	1.5	-	V
		V <sub>CC</sub> = 4.5 V	3.15	2.4	-	3.15	-	V
		V <sub>CC</sub> = 6.0 V	4.2	3.2	-	4.2	-	V
		V <sub>CC</sub> = 9.0 V	6.3	4.7	-	6.3	-	V
V <sub>IL</sub>	LOW-level input voltage	V <sub>CC</sub> = 2.0 V	-	0.8	0.5	-	0.5	V
		V <sub>CC</sub> = 4.5 V	-	2.1	1.35	-	1.35	V
		V <sub>CC</sub> = 6.0 V	-	2.8	1.8	-	1.8	V
		V <sub>CC</sub> = 9.0 V	-	4.3	2.7	-	2.7	V
I <sub>I</sub>	input leakage current	E; V <sub>I</sub> = V <sub>CC</sub> or GND						
		V <sub>CC</sub> = 6.0 V	-	0.1	1.0	-	1.0	μA
		V <sub>CC</sub> = 10.0 V	-	0.2	2.0	-	2.0	μA
I <sub>S(OFF)</sub>	OFF-state leakage current	Y or Z; V <sub>CC</sub> = 10 V; see <a href="#">Figure 4</a>	-	0.1	1.0	-	1.0	μA
I <sub>S(ON)</sub>	ON-state leakage current	Y or Z; V <sub>CC</sub> = 10 V; see <a href="#">Figure 5</a>	-	0.1	1.0	-	1.0	μA
I <sub>CC</sub>	supply current	E, Y or Z; V <sub>I</sub> = V <sub>CC</sub> or GND; V <sub>SW</sub> = GND or V <sub>CC</sub>						
		V <sub>CC</sub> = 6.0 V	-	1.0	10	-	20	μA
		V <sub>CC</sub> = 10.0 V	-	2.0	20	-	40	μA
C <sub>I</sub>	input capacitance		-	1.5	-	-	-	pF
C <sub>S(ON)</sub>	ON-state capacitance		-	8	-	-	-	pF

**Table 7. Static characteristics ...continued**  
 Voltages are referenced to GND (ground = 0 V).

Symbol	Parameter	Conditions	-40 °C to +85 °C			-40 °C to +125 °C		Unit
			Min	Typ <sup>[1]</sup>	Max	Min	Max	
<b>74HCT1G66-Q100</b>								
V <sub>IH</sub>	HIGH-level input voltage	V <sub>CC</sub> = 4.5 V to 5.5 V	2.0	1.6	-	2.0	-	V
V <sub>IL</sub>	LOW-level input voltage	V <sub>CC</sub> = 4.5 V to 5.5 V	0.1	1.2	0.8	-	0.8	V
I <sub>I</sub>	input leakage current	E; V <sub>I</sub> = V <sub>CC</sub> or GND; V <sub>CC</sub> = 5.5 V	-	0.1	1.0	-	1.0	μA
I <sub>S(OFF)</sub>	OFF-state leakage current	Y or Z; V <sub>CC</sub> = 5.5 V; see <a href="#">Figure 4</a>	-	0.1	1.0	-	1.0	μA
I <sub>S(ON)</sub>	ON-state leakage current	Y or Z; V <sub>CC</sub> = 5.5 V; see <a href="#">Figure 5</a>	-	0.1	1.0	-	1.0	μA
I <sub>CC</sub>	supply current	E, Y or Z; V <sub>I</sub> = V <sub>CC</sub> or GND; V <sub>SW</sub> = GND or V <sub>CC</sub> ; V <sub>CC</sub> = 4.5 V to 5.5 V	-	1	10	-	20	μA
ΔI <sub>CC</sub>	additional supply current	V <sub>I</sub> = V <sub>CC</sub> - 2.1 V; V <sub>CC</sub> = 4.5 V to 5.5 V; I <sub>O</sub> = 0 A	-	-	500	-	850	μA
C <sub>I</sub>	input capacitance		-	1.5	-	-	-	pF
C <sub>S(ON)</sub>	ON-state capacitance		-	8	-	-	-	pF

[1] Typical values are measured at T<sub>amb</sub> = 25 °C.

**10.1 Test circuits**

V<sub>I</sub> = V<sub>CC</sub> or GND and V<sub>O</sub> = GND or V<sub>CC</sub>.

**Fig 4. Test circuit for measuring OFF-state leakage current**

V<sub>I</sub> = V<sub>CC</sub> or GND and V<sub>O</sub> = open circuit.

**Fig 5. Test circuit for measuring ON-state leakage current**

10.2 ON resistance

**Table 8. ON resistance**

At recommended operating conditions; voltages are referenced to GND (ground 0 V); for graph see [Figure 7](#).

Symbol	Parameter	Conditions	-40 °C to +85 °C			-40 °C to +125 °C		Unit
			Min	Typ <sup>[2]</sup>	Max	Min	Max	
<b>74HC1G66-Q100<sup>[1]</sup></b>								
R <sub>ON(peak)</sub>	ON resistance (peak)	V <sub>I</sub> = GND to V <sub>CC</sub> ; see <a href="#">Figure 6</a>						
		I <sub>SW</sub> = 0.1 mA; V <sub>CC</sub> = 2.0 V	-	-	-	-	-	Ω
		I <sub>SW</sub> = 1 mA; V <sub>CC</sub> = 4.5 V	-	42	118	-	142	Ω
		I <sub>SW</sub> = 1 mA; V <sub>CC</sub> = 6.0 V	-	31	105	-	126	Ω
		I <sub>SW</sub> = 1 mA; V <sub>CC</sub> = 9.0 V	-	23	88	-	105	Ω
R <sub>ON(rail)</sub>	ON resistance (rail)	V <sub>I</sub> = GND; see <a href="#">Figure 6</a>						
		I <sub>SW</sub> = 0.1 mA; V <sub>CC</sub> = 2.0 V	-	75	-	-	-	Ω
		I <sub>SW</sub> = 1 mA; V <sub>CC</sub> = 4.5 V	-	29	95	-	115	Ω
		I <sub>SW</sub> = 1 mA; V <sub>CC</sub> = 6.0 V	-	23	82	-	100	Ω
		I <sub>SW</sub> = 1 mA; V <sub>CC</sub> = 9.0 V	-	18	70	-	80	Ω
		V <sub>I</sub> = V <sub>CC</sub> ; see <a href="#">Figure 6</a>						
		I <sub>SW</sub> = 0.1 mA; V <sub>CC</sub> = 2.0 V	-	75	-	-	-	Ω
		I <sub>SW</sub> = 1 mA; V <sub>CC</sub> = 4.5 V	-	35	106	-	128	Ω
		I <sub>SW</sub> = 1 mA; V <sub>CC</sub> = 6.0 V	-	27	94	-	113	Ω
		I <sub>SW</sub> = 1 mA; V <sub>CC</sub> = 9.0 V	-	21	78	-	95	Ω
<b>74HCT1G66-Q100</b>								
R <sub>ON(peak)</sub>	ON resistance (peak)	V <sub>I</sub> = GND to V <sub>CC</sub> ; see <a href="#">Figure 6</a>						
		I <sub>SW</sub> = 1 mA; V <sub>CC</sub> = 4.5 V	-	42	118	-	142	Ω
R <sub>ON(rail)</sub>	ON resistance (rail)	V <sub>I</sub> = GND; see <a href="#">Figure 6</a>						
		I <sub>SW</sub> = 1 mA; V <sub>CC</sub> = 4.5 V	-	29	95	-	115	Ω
		V <sub>I</sub> = V <sub>CC</sub> ; see <a href="#">Figure 6</a>						
		I <sub>SW</sub> = 1 mA; V <sub>CC</sub> = 4.5 V	-	35	106	-	128	Ω

[1] At supply voltages approaching 2 V, the ON resistance becomes extremely non-linear. Therefore it is recommended that these devices be used to transmit digital signals only, when using this supply voltage.

[2] Typical values are measured at T<sub>amb</sub> = 25 °C.



10.3 ON resistance test circuit and graphs

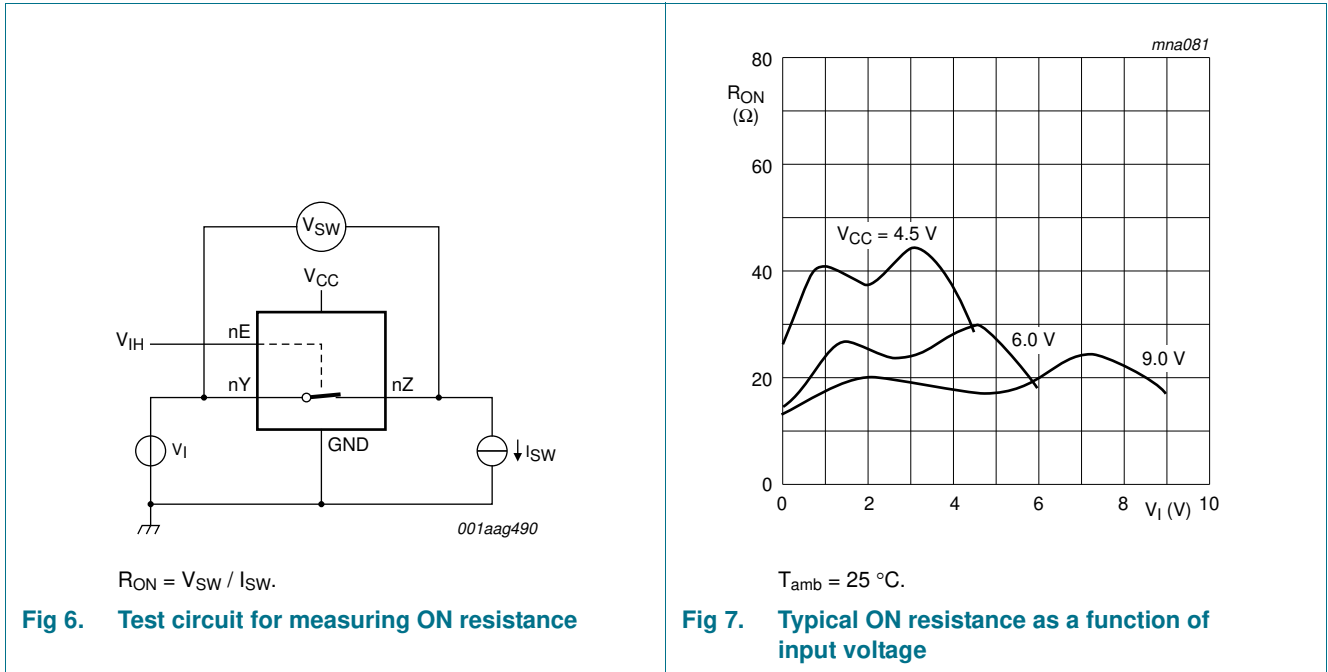

Fig 6. Test circuit for measuring ON resistance

Fig 7. Typical ON resistance as a function of input voltage

11. Dynamic characteristics

Table 9. Dynamic characteristics

Voltages are referenced to GND (ground = 0 V); C<sub>L</sub> = 50 pF; R<sub>L</sub> = 1 kΩ, unless otherwise specified; For test circuit, see Figure 10.

Symbol	Parameter	Conditions	-40 °C to +85 °C			-40 °C to +125 °C		Unit
			Min	Typ <sup>[1]</sup>	Max	Min	Max	
<b>74HC1G66-Q100</b>								
t <sub>pd</sub>	propagation delay	Y to Z or Z to Y; R <sub>L</sub> = ∞ Ω; see Figure 8		[2]				
		V <sub>CC</sub> = 2.0 V	-	8	75	-	90	ns
		V <sub>CC</sub> = 4.5 V	-	3	15	-	18	ns
		V <sub>CC</sub> = 6.0 V	-	2	13	-	15	ns
		V <sub>CC</sub> = 9.0 V	-	1	10	-	12	ns
t <sub>en</sub>	enable time	E to Y or Z; see Figure 9		[2]				
		V <sub>CC</sub> = 2.0 V	-	50	125	-	150	ns
		V <sub>CC</sub> = 4.5 V	-	16	25	-	30	ns
		V <sub>CC</sub> = 5.0 V; C <sub>L</sub> = 15 pF	-	11	-	-	-	ns
		V <sub>CC</sub> = 6.0 V	-	13	21	-	26	ns
		V <sub>CC</sub> = 9.0 V	-	9	16	-	20	ns

**Table 9. Dynamic characteristics ...continued**

Voltages are referenced to GND (ground = 0 V);  $C_L = 50 \text{ pF}$ ;  $R_L = 1 \text{ k}\Omega$ , unless otherwise specified;  
For test circuit, see [Figure 10](#).

Symbol	Parameter	Conditions	-40 °C to +85 °C			-40 °C to +125 °C		Unit
			Min	Typ <sup>[1]</sup>	Max	Min	Max	
$t_{dis}$	disable time	E to Y or Z; see <a href="#">Figure 9</a>						
		$V_{CC} = 2.0 \text{ V}$	-	27	190	-	225	ns
		$V_{CC} = 4.5 \text{ V}$	-	16	38	-	45	ns
		$V_{CC} = 5.0 \text{ V}$ ; $C_L = 15 \text{ pF}$	-	11	-	-	-	ns
		$V_{CC} = 6.0 \text{ V}$	-	14	33	-	38	ns
		$V_{CC} = 9.0 \text{ V}$	-	12	16	-	20	ns
$C_{PD}$	power dissipation capacitance	$V_I = \text{GND to } V_{CC}$						
			-	9	-	-	-	pF

**74HCT1G66-Q100**

$t_{pd}$	propagation delay	Y to Z or Z to Y; $R_L = \infty \Omega$ ; see <a href="#">Figure 8</a>						
		$V_{CC} = 4.5 \text{ V}$	-	3	15	-	18	ns
$t_{en}$	enable time	E to Y or Z; see <a href="#">Figure 9</a>						
		$V_{CC} = 4.5 \text{ V}$	-	15	30	-	36	ns
		$V_{CC} = 5.0 \text{ V}$ ; $C_L = 15 \text{ pF}$	-	12	-	-	-	ns
$t_{dis}$	disable time	E to Y or Z; see <a href="#">Figure 9</a>						
		$V_{CC} = 4.5 \text{ V}$	-	13	44	-	53	ns
		$V_{CC} = 5.0 \text{ V}$ ; $C_L = 15 \text{ pF}$	-	12	-	-	-	ns
$C_{PD}$	power dissipation capacitance	$V_I = \text{GND to } V_{CC} - 1.5 \text{ V}$						
			-	9	-	-	-	pF

- [1] All typical values are measured at  $T_{amb} = 25 \text{ }^\circ\text{C}$ .
- [2]  $t_{pd}$  is the same as  $t_{PLH}$  and  $t_{PHL}$ .  
 $t_{en}$  is the same as  $t_{PZL}$  and  $t_{PZH}$ .  
 $t_{dis}$  is the same as  $t_{PLZ}$  and  $t_{PHZ}$ .
- [3]  $C_{PD}$  is used to determine the dynamic power dissipation  $P_D$  ( $\mu\text{W}$ ).  
 $P_D = C_{PD} \times V_{CC}^2 \times f_i + \Sigma ((C_L \times C_{SW}) \times V_{CC}^2 \times f_o)$  where:  
 $f_i$  = input frequency in MHz;  
 $f_o$  = output frequency in MHz;  
 $C_L$  = output load capacitance in pF;  
 $C_{SW}$  = maximum switch capacitance in pF (see [Table 7](#));  
 $V_{CC}$  = supply voltage in Volt;  
 $\Sigma ((C_L \times C_{SW}) \times V_{CC}^2 \times f_o)$  = sum of outputs.

11.1 Waveforms and test circuit

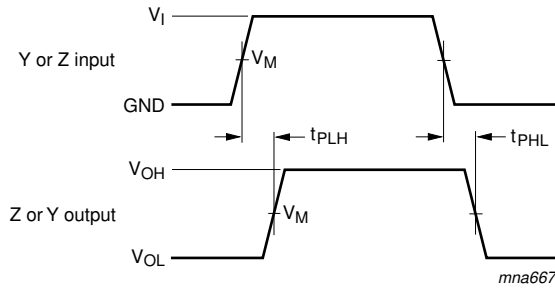

Measurement points are given in [Table 10](#).  
 Logic levels:  $V_{OL}$  and  $V_{OH}$  are typical output voltage levels that occur with the output load.

**Fig 8. Input (Y or Z) to output (Z or Y) propagation delays**

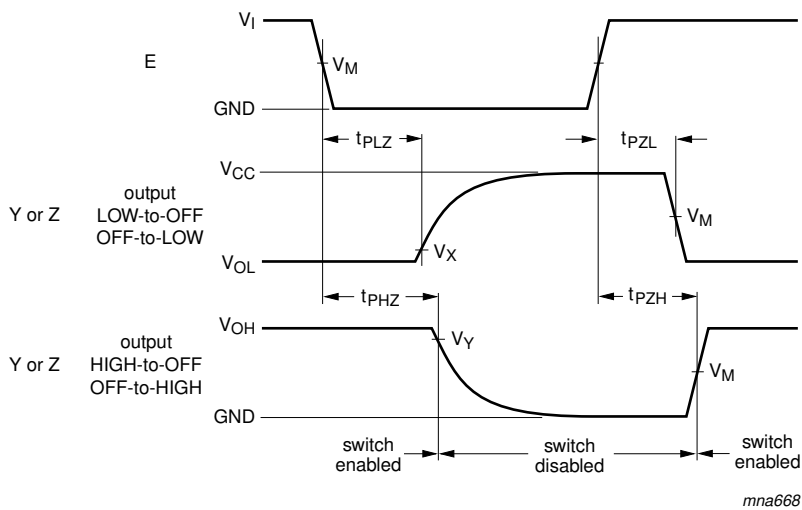

Measurement points are given in [Table 10](#).  
 Logic levels:  $V_{OL}$  and  $V_{OH}$  are typical output voltage levels that occur with the output load.

**Fig 9. Enable and disable times**

**Table 10. Measurement points**

Type	Input	Output		
	$V_M$	$V_M$	$V_X$	$V_Y$
74HC1G66-Q100	$0.5V_{CC}$	$0.5V_{CC}$	$V_{OL} + 10\%$	$V_{OH} - 10\%$
74HCT1G66-Q100	1.3 V	1.3 V	$V_{OL} + 10\%$	$V_{OH} - 10\%$

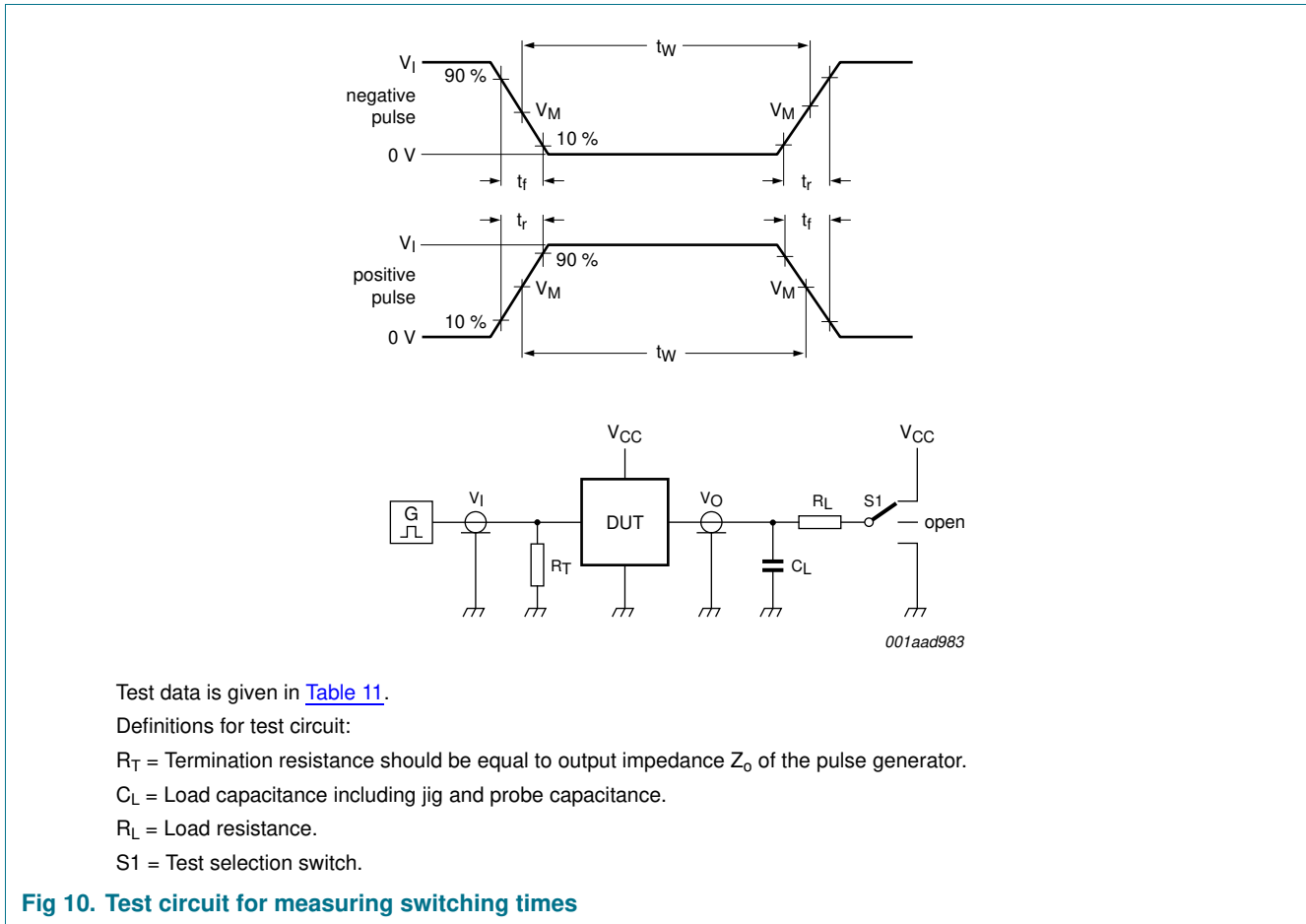

**Table 11. Test data**

Type	Input		Load		S1 position		
	$V_I$	$t_r, t_f$ <sup>[1]</sup>	$C_L$	$R_L$	$t_{PHL}, t_{PLH}$	$t_{PZH}, t_{PHZ}$	$t_{PZL}, t_{PLZ}$
74HC1G66-Q100	GND to $V_{CC}$	6 ns	50 pF, 15 pF	1 k $\Omega$ , $\infty \Omega$	open	GND	$V_{CC}$
74HCT1G66-Q100	GND to 3 V	6 ns	50 pF, 15 pF	1 k $\Omega$ , $\infty \Omega$	open	GND	$V_{CC}$

[1] There is no constraint on  $t_r, t_f$  with a 50% duty factor when measuring  $f_{max}$ .

## 11.2 Additional dynamic characteristics

**Table 12. Additional dynamic characteristics for 74HC1G66-Q100 and 74HCT1G66-Q100**

$GND = 0 V$ ;  $t_r = t_f = 6.0 ns$ ;  $C_L = 50 pF$ ; unless otherwise specified. All typical values are measured at  $T_{amb} = 25 \text{ }^\circ C$ .

Symbol	Parameter	Conditions	Min	Typ	Max	Unit	
THD	total harmonic distortion	$f_i = 1 \text{ kHz}$ ; $R_L = 10 \text{ k}\Omega$ ; see <a href="#">Figure 11</a>				%	
		$V_{CC} = 4.5 \text{ V}$ ; $V_I = 4.0 \text{ V (p-p)}$	-	0.04	-	%	
		$V_{CC} = 9.0 \text{ V}$ ; $V_I = 8.0 \text{ V (p-p)}$	-	0.02	-	%	
		$f_i = 10 \text{ kHz}$ ; $R_L = 10 \text{ k}\Omega$ ; see <a href="#">Figure 11</a>					
		$V_{CC} = 4.5 \text{ V}$ ; $V_I = 4.0 \text{ V (p-p)}$	-	0.12	-	%	
		$V_{CC} = 9.0 \text{ V}$ ; $V_I = 8.0 \text{ V (p-p)}$	-	0.06	-	%	

**Table 12. Additional dynamic characteristics for 74HC1G66-Q100 and 74HCT1G66-Q100 ...continued**  
*GND = 0 V;  $t_r = t_f = 6.0$  ns;  $C_L = 50$  pF; unless otherwise specified. All typical values are measured at  $T_{amb} = 25$  °C.*

Symbol	Parameter	Conditions	Min	Typ	Max	Unit
$f_{(-3dB)}$	-3 dB frequency response	$R_L = 50 \Omega$ ; $C_L = 10$ pF; see <a href="#">Figure 12</a> and <a href="#">13</a>	-	-	-	-
		$V_{CC} = 4.5$ V	-	180	-	MHz
		$V_{CC} = 9.0$ V	-	200	-	MHz
$\alpha_{iso}$	isolation (OFF-state)	$R_L = 600 \Omega$ ; $f_i = 1$ MHz; see <a href="#">Figure 14</a> and <a href="#">15</a>	-	-	-	-
		$V_{CC} = 4.5$ V	-	-50	-	dB
		$V_{CC} = 9.0$ V	-	-50	-	dB

11.3 Test circuits and graphs

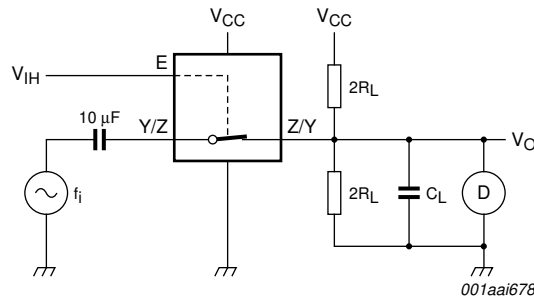
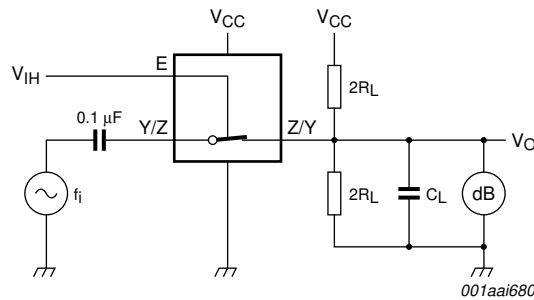
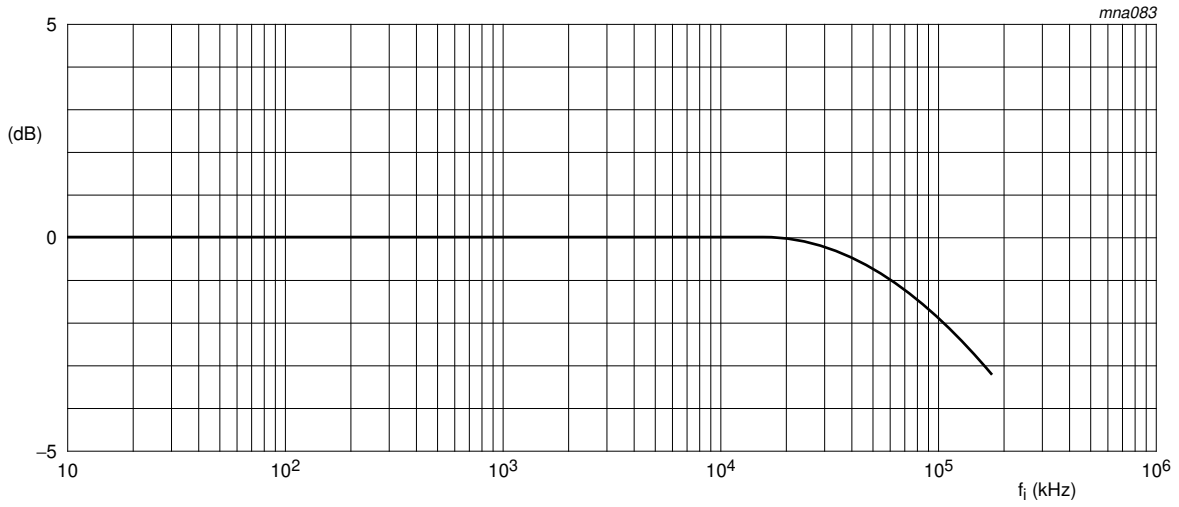

Fig 11. Test circuit for measuring total harmonic distortion



With  $f_i = 1$  MHz, adjust the switch input voltage for a 0 dBm level at the switch output (0 dBm = 1 mW into 50  $\Omega$ ). Then increase the input frequency until the dB meter reads -3 dB

Fig 12. Test circuit for measuring the -3 dB frequency response



Test conditions:  $V_{CC} = 4.5\text{ V}$ ;  $GND = 0\text{ V}$ ;  $R_L = 50\ \Omega$ ;  $R_{SOURCE} = 1\text{ k}\Omega$ .

**Fig 13. Typical -3 dB frequency response**

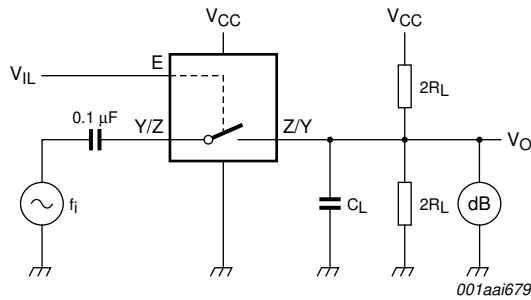

Adjust the switch input voltage for a 0 dBm level (0 dBm = 1 mW into 600  $\Omega$ )

**Fig 14. Test circuit for measuring isolation (OFF-state)**

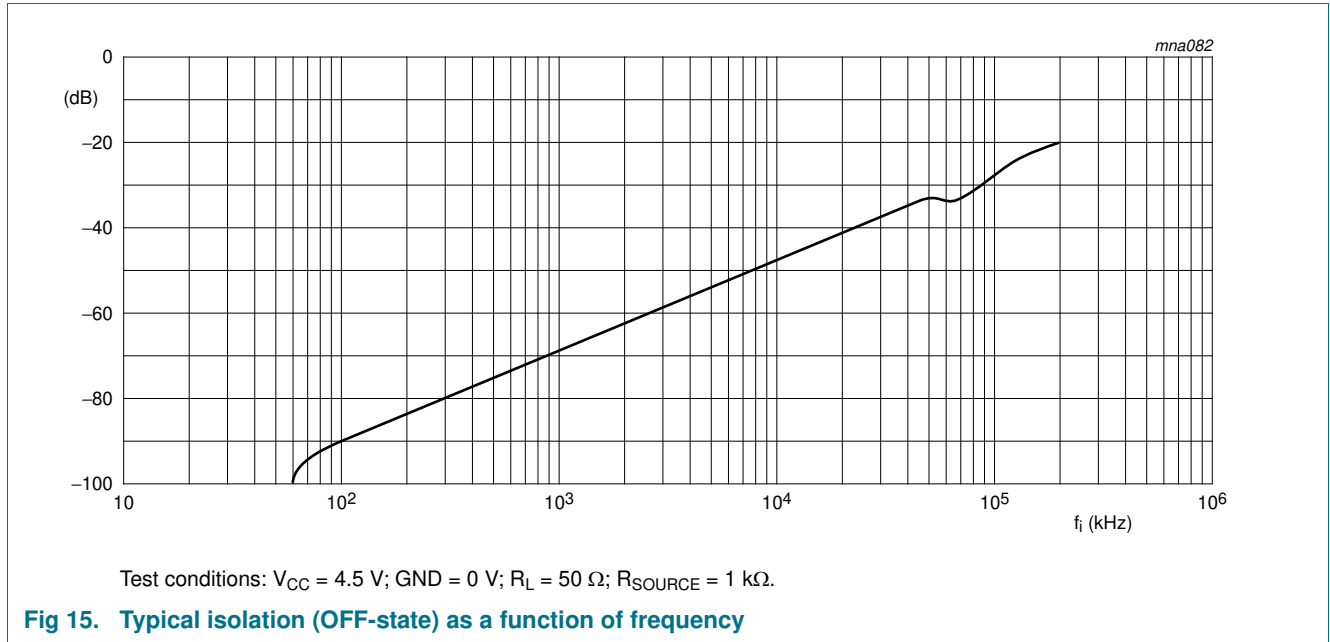

12. Package outline

TSSOP5: plastic thin shrink small outline package; 5 leads; body width 1.25 mm

SOT353-1

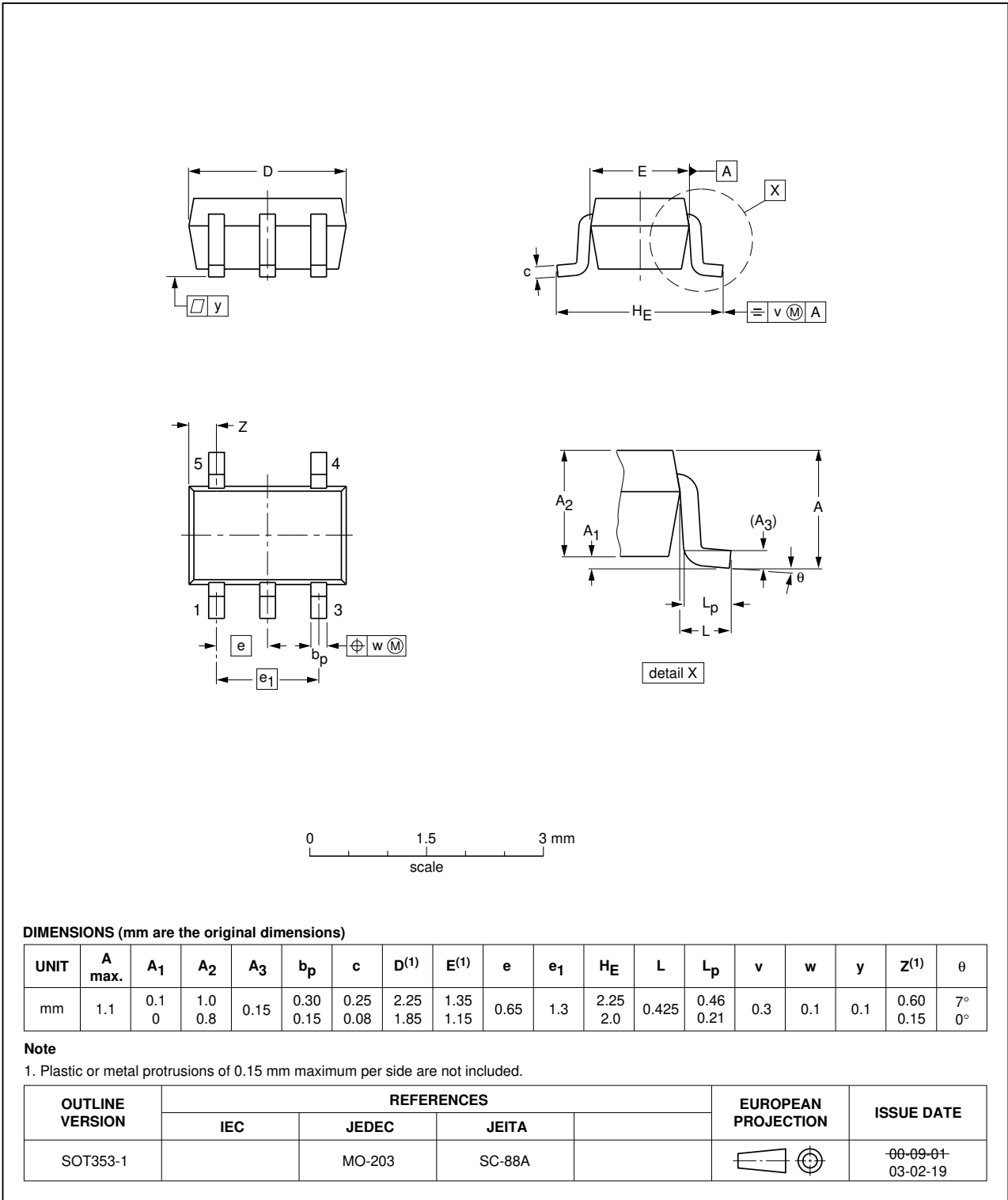

Fig 16. Package outline SOT353-1 (TSSOP5)



Plastic surface-mounted package; 5 leads

SOT753

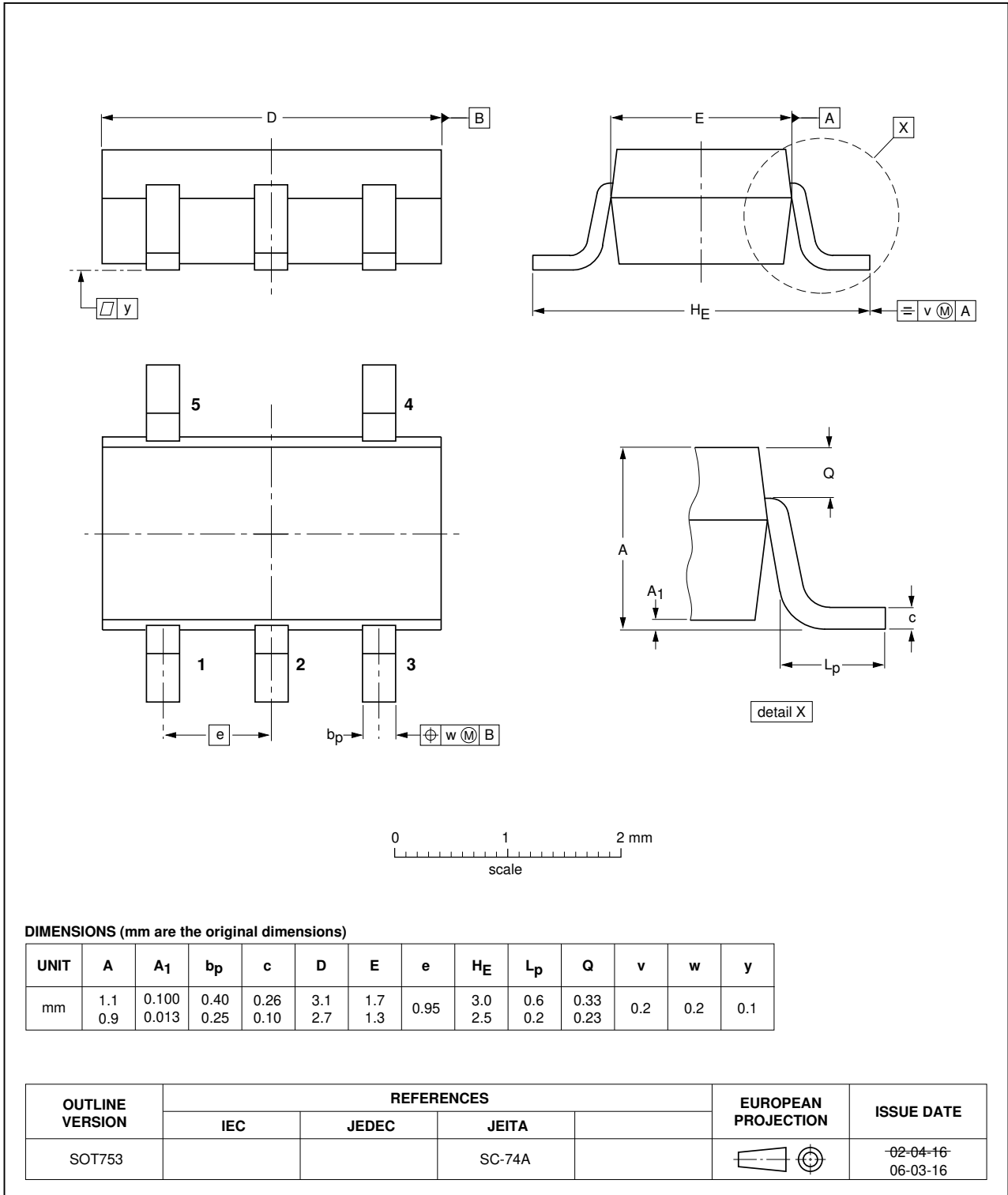

Fig 17. Package outline SOT753 (SC-74A)

## 13. Abbreviations

Table 13. Abbreviations

Acronym	Description
CMOS	Complementary Metal-Oxide Semiconductor
ESD	ElectroStatic Discharge
HBM	Human Body Model
MM	Machine Model
TTL	Transistor-Transistor Logic
DUT	Device Under Test

## 14. Revision history

Table 14. Revision history

Document ID	Release date	Data sheet status	Change notice	Supersedes
74HC_HCT1G66_Q100 v.1	20130916	Product data sheet	-	-

## 15. Legal information

### 15.1 Data sheet status

Document status <sup>[1][2]</sup>	Product status <sup>[3]</sup>	Definition
Objective [short] data sheet	Development	This document contains data from the objective specification for product development.
Preliminary [short] data sheet	Qualification	This document contains data from the preliminary specification.
Product [short] data sheet	Production	This document contains the product specification.

[1] Please consult the most recently issued document before initiating or completing a design.

[2] The term 'short data sheet' is explained in section "Definitions".

[3] The product status of device(s) described in this document may have changed since this document was published and may differ in case of multiple devices. The latest product status information is available on the Internet at URL <http://www.nxp.com>.

### 15.2 Definitions

**Draft** — The document is a draft version only. The content is still under internal review and subject to formal approval, which may result in modifications or additions. NXP Semiconductors does not give any representations or warranties as to the accuracy or completeness of information included herein and shall have no liability for the consequences of use of such information.

**Short data sheet** — A short data sheet is an extract from a full data sheet with the same product type number(s) and title. A short data sheet is intended for quick reference only and should not be relied upon to contain detailed and full information. For detailed and full information see the relevant full data sheet, which is available on request via the local NXP Semiconductors sales office. In case of any inconsistency or conflict with the short data sheet, the full data sheet shall prevail.

**Product specification** — The information and data provided in a Product data sheet shall define the specification of the product as agreed between NXP Semiconductors and its customer, unless NXP Semiconductors and customer have explicitly agreed otherwise in writing. In no event however, shall an agreement be valid in which the NXP Semiconductors product is deemed to offer functions and qualities beyond those described in the Product data sheet.

### 15.3 Disclaimers

**Limited warranty and liability** — Information in this document is believed to be accurate and reliable. However, NXP Semiconductors does not give any representations or warranties, expressed or implied, as to the accuracy or completeness of such information and shall have no liability for the consequences of use of such information. NXP Semiconductors takes no responsibility for the content in this document if provided by an information source outside of NXP Semiconductors.

In no event shall NXP Semiconductors be liable for any indirect, incidental, punitive, special or consequential damages (including - without limitation - lost profits, lost savings, business interruption, costs related to the removal or replacement of any products or rework charges) whether or not such damages are based on tort (including negligence), warranty, breach of contract or any other legal theory.

Notwithstanding any damages that customer might incur for any reason whatsoever, NXP Semiconductors' aggregate and cumulative liability towards customer for the products described herein shall be limited in accordance with the *Terms and conditions of commercial sale* of NXP Semiconductors.

**Right to make changes** — NXP Semiconductors reserves the right to make changes to information published in this document, including without limitation specifications and product descriptions, at any time and without notice. This document supersedes and replaces all information supplied prior to the publication hereof.

**Suitability for use in automotive applications** — This NXP Semiconductors product has been qualified for use in automotive applications. Unless otherwise agreed in writing, the product is not designed, authorized or warranted to be suitable for use in life support, life-critical or safety-critical systems or equipment, nor in applications where failure or malfunction of an NXP Semiconductors product can reasonably be expected to result in personal injury, death or severe property or environmental damage. NXP Semiconductors and its suppliers accept no liability for inclusion and/or use of NXP Semiconductors products in such equipment or applications and therefore such inclusion and/or use is at the customer's own risk.

**Applications** — Applications that are described herein for any of these products are for illustrative purposes only. NXP Semiconductors makes no representation or warranty that such applications will be suitable for the specified use without further testing or modification.

Customers are responsible for the design and operation of their applications and products using NXP Semiconductors products, and NXP Semiconductors accepts no liability for any assistance with applications or customer product design. It is customer's sole responsibility to determine whether the NXP Semiconductors product is suitable and fit for the customer's applications and products planned, as well as for the planned application and use of customer's third party customer(s). Customers should provide appropriate design and operating safeguards to minimize the risks associated with their applications and products.

NXP Semiconductors does not accept any liability related to any default, damage, costs or problem which is based on any weakness or default in the customer's applications or products, or the application or use by customer's third party customer(s). Customer is responsible for doing all necessary testing for the customer's applications and products using NXP Semiconductors products in order to avoid a default of the applications and the products or of the application or use by customer's third party customer(s). NXP does not accept any liability in this respect.

**Limiting values** — Stress above one or more limiting values (as defined in the Absolute Maximum Ratings System of IEC 60134) will cause permanent damage to the device. Limiting values are stress ratings only and (proper) operation of the device at these or any other conditions above those given in the Recommended operating conditions section (if present) or the Characteristics sections of this document is not warranted. Constant or repeated exposure to limiting values will permanently and irreversibly affect the quality and reliability of the device.

**Terms and conditions of commercial sale** — NXP Semiconductors products are sold subject to the general terms and conditions of commercial sale, as published at <http://www.nxp.com/profile/terms>, unless otherwise agreed in a valid written individual agreement. In case an individual agreement is concluded only the terms and conditions of the respective agreement shall apply. NXP Semiconductors hereby expressly objects to applying the customer's general terms and conditions with regard to the purchase of NXP Semiconductors products by customer.

**No offer to sell or license** — Nothing in this document may be interpreted or construed as an offer to sell products that is open for acceptance or the grant, conveyance or implication of any license under any copyrights, patents or other industrial or intellectual property rights.

**Export control** — This document as well as the item(s) described herein may be subject to export control regulations. Export might require a prior authorization from competent authorities.

**Translations** — A non-English (translated) version of a document is for reference only. The English version shall prevail in case of any discrepancy between the translated and English versions.

## 15.4 Trademarks

Notice: All referenced brands, product names, service names and trademarks are the property of their respective owners.

## 16. Contact information

---

For more information, please visit: <http://www.nxp.com>

For sales office addresses, please send an email to: [salesaddresses@nxp.com](mailto:salesaddresses@nxp.com)

## 17. Contents

<b>1</b>	<b>General description</b> .....	<b>1</b>
<b>2</b>	<b>Features and benefits</b> .....	<b>1</b>
<b>3</b>	<b>Ordering information</b> .....	<b>1</b>
<b>4</b>	<b>Marking</b> .....	<b>2</b>
<b>5</b>	<b>Functional diagram</b> .....	<b>2</b>
<b>6</b>	<b>Pinning information</b> .....	<b>2</b>
6.1	Pinning .....	2
6.2	Pin description .....	2
<b>7</b>	<b>Functional description</b> .....	<b>3</b>
<b>8</b>	<b>Limiting values</b> .....	<b>3</b>
<b>9</b>	<b>Recommended operating conditions</b> .....	<b>3</b>
<b>10</b>	<b>Static characteristics</b> .....	<b>4</b>
10.1	Test circuits .....	5
10.2	ON resistance .....	6
10.3	ON resistance test circuit and graphs .....	7
<b>11</b>	<b>Dynamic characteristics</b> .....	<b>7</b>
11.1	Waveforms and test circuit .....	9
11.2	Additional dynamic characteristics .....	10
11.3	Test circuits and graphs .....	11
<b>12</b>	<b>Package outline</b> .....	<b>14</b>
<b>13</b>	<b>Abbreviations</b> .....	<b>16</b>
<b>14</b>	<b>Revision history</b> .....	<b>16</b>
<b>15</b>	<b>Legal information</b> .....	<b>17</b>
15.1	Data sheet status .....	17
15.2	Definitions .....	17
15.3	Disclaimers .....	17
15.4	Trademarks .....	18
<b>16</b>	<b>Contact information</b> .....	<b>18</b>
<b>17</b>	<b>Contents</b> .....	<b>19</b>

Please be aware that important notices concerning this document and the product(s) described herein, have been included in section 'Legal information'.

© NXP B.V. 2013.

All rights reserved.

For more information, please visit: <http://www.nxp.com>

For sales office addresses, please send an email to: [salesaddresses@nxp.com](mailto:salesaddresses@nxp.com)

Date of release: 16 September 2013

Document identifier: 74HC\_HCT1G66\_Q100