



Chipsmall Limited consists of a professional team with an average of over 10 year of expertise in the distribution of electronic components. Based in Hongkong, we have already established firm and mutual-benefit business relationships with customers from,Europe,America and south Asia,supplying obsolete and hard-to-find components to meet their specific needs.

With the principle of “Quality Parts,Customers Priority,Honest Operation,and Considerate Service”,our business mainly focus on the distribution of electronic components. Line cards we deal with include Microchip,ALPS,ROHM,Xilinx,Pulse,ON,Everlight and Freescale. Main products comprise IC,Modules,Potentiometer,IC Socket,Relay,Connector.Our parts cover such applications as commercial,industrial, and automotives areas.

We are looking forward to setting up business relationship with you and hope to provide you with the best service and solution. Let us make a better world for our industry!



Contact us

Tel: +86-755-8981 8866 Fax: +86-755-8427 6832

Email & Skype: info@chipsmall.com Web: www.chipsmall.com

Address: A1208, Overseas Decoration Building, #122 Zhenhua RD., Futian, Shenzhen, China



74HC4052; 74HCT4052

Dual 4-channel analog multiplexer/demultiplexer

Rev. 10 — 19 July 2012

Product data sheet

1. General description

The 74HC4052; 74HCT4052 is a high-speed Si-gate CMOS device and is pin compatible with the HEF4052B. The device is specified in compliance with JEDEC standard no. 7A.

The 74HC4052; 74HCT4052 is a dual 4-channel analog multiplexer/demultiplexer with common select logic. Each multiplexer has four independent inputs/outputs (pins nY0 to nY3) and a common input/output (pin nZ). The common channel select logics include two digital select inputs (pins S0 and S1) and an active LOW enable input (pin \bar{E}). When pin \bar{E} = LOW, one of the four switches is selected (low-impedance ON-state) with pins S0 and S1. When pin \bar{E} = HIGH, all switches are in the high-impedance OFF-state, independent of pins S0 and S1.

V_{CC} and GND are the supply voltage pins for the digital control inputs (pins S0, S1 and \bar{E}). The V_{CC} to GND ranges are 2.0 V to 10.0 V for the 74HC4052 and 4.5 V to 5.5 V for the 74HCT4052. The analog inputs/outputs (pins nY0 to nY3 and nZ) can swing between V_{CC} as a positive limit and V_{EE} as a negative limit. $V_{CC} - V_{EE}$ may not exceed 10.0 V.

For operation as a digital multiplexer/demultiplexer, V_{EE} is connected to GND (typically ground).

2. Features and benefits

- Wide analog input voltage range from -5 V to +5 V
- Low ON resistance:
 - ◆ 80 Ω (typical) at $V_{CC} - V_{EE} = 4.5$ V
 - ◆ 70 Ω (typical) at $V_{CC} - V_{EE} = 6.0$ V
 - ◆ 60 Ω (typical) at $V_{CC} - V_{EE} = 9.0$ V
- Logic level translation: to enable 5 V logic to communicate with ± 5 V analog signals
- Typical 'break before make' built-in
- Complies with JEDEC standard no. 7A
- ESD protection:
 - ◆ HBM JESD22-A114F exceeds 2000 V
 - ◆ MM JESD22-A115-A exceeds 200 V
 - ◆ CDM JESD22-C101E exceeds 1000 V
- Specified from -40 °C to +85 °C and -40 °C to +125 °C



3. Applications

- Analog multiplexing and demultiplexing
- Digital multiplexing and demultiplexing
- Signal gating

4. Ordering information

Table 1. Ordering information

Type number	Package			
	Temperature range	Name	Description	Version
74HC4052				
74HC4052N	–40 °C to +125 °C	DIP16	plastic dual in-line package; 16 leads (300 mil)	SOT38-4
74HC4052D	–40 °C to +125 °C	SO16	plastic small outline package; 16 leads; body width 3.9 mm	SOT109-1
74HC4052DB	–40 °C to +125 °C	SSOP16	plastic shrink small outline package; 16 leads; body width 5.3 mm	SOT338-1
74HC4052PW	–40 °C to +125 °C	TSSOP16	plastic thin shrink small outline package; 16 leads; body width 4.4 mm	SOT403-1
74HC4052BQ	–40 °C to +125 °C	DHVQFN16	plastic dual-in line compatible thermal enhanced very thin quad flat package; no leads; 16 terminals; body 2.5 × 3.5 × 0.85 mm	SOT763-1
74HCT4052				
74HCT4052N	–40 °C to +125 °C	DIP16	plastic dual in-line package; 16 leads (300 mil)	SOT38-4
74HCT4052D	–40 °C to +125 °C	SO16	plastic small outline package; 16 leads; body width 3.9 mm	SOT109-1
74HCT4052DB	–40 °C to +125 °C	SSOP16	plastic shrink small outline package; 16 leads; body width 5.3 mm	SOT338-1
74HCT4052PW	–40 °C to +125 °C	TSSOP16	plastic thin shrink small outline package; 16 leads; body width 4.4 mm	SOT403-1
74HCT4052BQ	–40 °C to +125 °C	DHVQFN16	plastic dual-in line compatible thermal enhanced very thin quad flat package; no leads; 16 terminals; body 2.5 × 3.5 × 0.85 mm	SOT763-1

5. Functional diagram

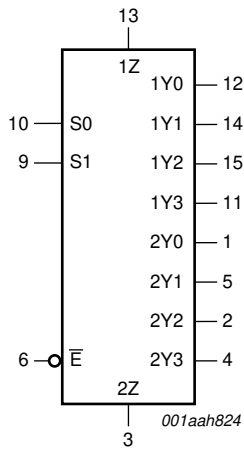

Fig 1. Logic symbol

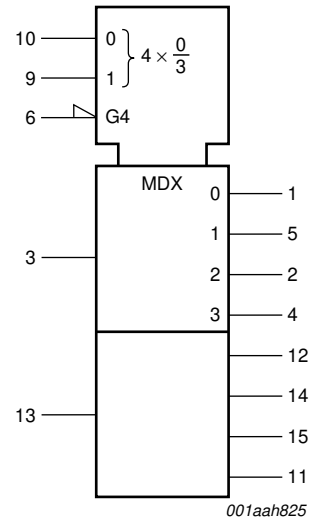

Fig 2. IEC logic symbol

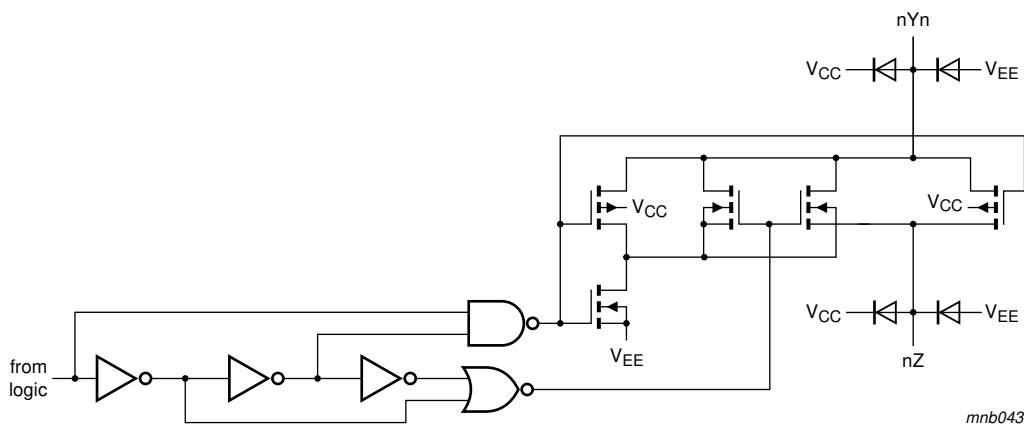

Fig 3. Schematic diagram (one switch)

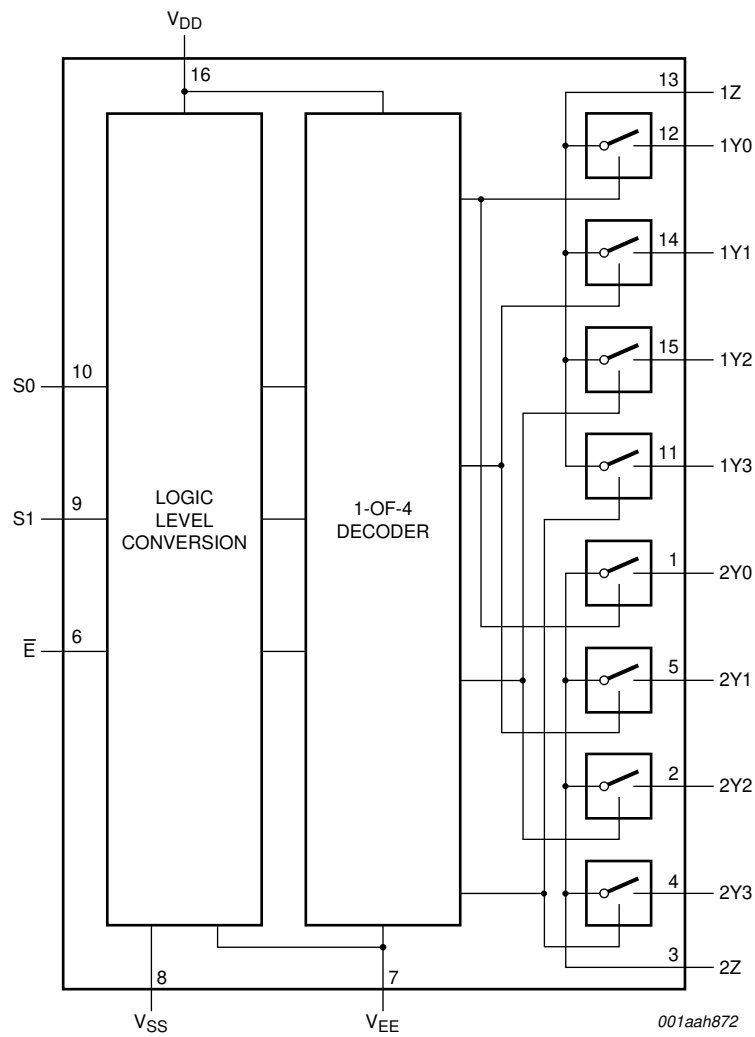
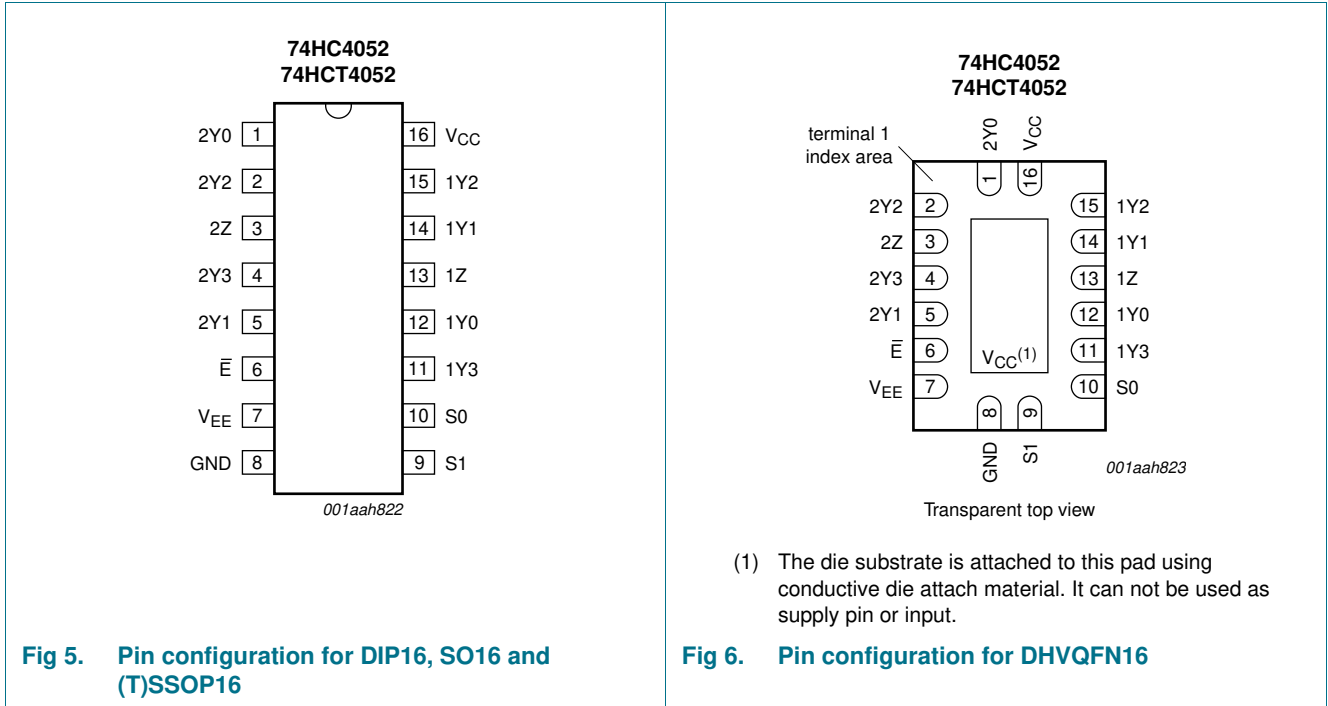

Fig 4. Functional diagram

6. Pinning information

6.1 Pinning



6.2 Pin description

Table 2. Pin description

Symbol	Pin	Description
2Y0	1	independent input or output 2Y0
2Y2	2	independent input or output 2Y2
2Z	3	common input or output 2
2Y3	4	independent input or output 2Y3
2Y1	5	independent input or output 2Y1
\bar{E}	6	enable input (active LOW)
V_{EE}	7	negative supply voltage
GND	8	ground (0 V)
S1	9	select logic input 1
S0	10	select logic input 0
1Y3	11	independent input or output 1Y3
1Y0	12	independent input or output 1Y0
1Z	13	common input or output 1
1Y1	14	independent input or output 1Y1
1Y2	15	independent input or output 1Y2
V_{CC}	16	positive supply voltage

7. Functional description

7.1 Function table

Table 3. Function table^[1]

Input			Channel on
\bar{E}	S1	S0	
L	L	L	nY0 and nZ
L	L	H	nY1 and nZ
L	H	L	nY2 and nZ
L	H	H	nY3 and nZ
H	X	X	none

- [1] H = HIGH voltage level;
L = LOW voltage level;
X = don't care.

8. Limiting values

Table 4. Limiting values

In accordance with the Absolute Maximum Rating System (IEC 60134).
Voltages are referenced to $V_{EE} = GND$ (ground = 0 V).

Symbol	Parameter	Conditions	Min	Max	Unit
V_{CC}	supply voltage		^[1] -0.5	+11.0	V
I_{IK}	input clamping current	$V_I < -0.5\text{ V}$ or $V_I > V_{CC} + 0.5\text{ V}$	-	± 20	mA
I_{SK}	switch clamping current	$V_{SW} < -0.5\text{ V}$ or $V_{SW} > V_{CC} + 0.5\text{ V}$	-	± 20	mA
I_{SW}	switch current	$-0.5\text{ V} < V_{SW} < V_{CC} + 0.5\text{ V}$	-	± 25	mA
I_{EE}	supply current		-	± 20	mA
I_{CC}	supply current		-	50	mA
I_{GND}	ground current		-	-50	mA
T_{stg}	storage temperature		-65	+150	°C
P_{tot}	total power dissipation	DIP16 package	^[2] -	750	mW
		SO16, (T)SSOP16, and DHVQFN16 package	^[3] -	500	mW
P	power dissipation	per switch	-	100	mW

- [1] To avoid drawing V_{CC} current out of pins nZ, when switch current flows in pins nYn, the voltage drop across the bidirectional switch must not exceed 0.4 V. If the switch current flows into pins nZ, no V_{CC} current will flow out of pins nYn. In this case there is no limit for the voltage drop across the switch, but the voltages at pins nYn and nZ may not exceed V_{CC} or V_{EE} .
- [2] For DIP16 packages: above 70 °C the value of P_{tot} derates linearly with 12 mW/K.
- [3] For SO16 packages: above 70 °C the value of P_{tot} derates linearly with 8 mW/K.
For SSOP16 and TSSOP16 packages: above 60 °C the value of P_{tot} derates linearly with 5.5 mW/K.
For DHVQFN16 packages: above 60 °C the value of P_{tot} derates linearly with 4.5 mW/K.

9. Recommended operating conditions

Table 5. Recommended operating conditions

Symbol	Parameter	Conditions	74HC4052			74HCT4052			Unit
			Min	Typ	Max	Min	Typ	Max	
V_{CC}	supply voltage	see Figure 7 and Figure 8							
		$V_{CC} - GND$	2.0	5.0	10.0	4.5	5.0	5.5	V
		$V_{CC} - V_{EE}$	2.0	5.0	10.0	2.0	5.0	10.0	V
V_I	input voltage		GND	-	V_{CC}	GND	-	V_{CC}	V
V_{SW}	switch voltage		V_{EE}	-	V_{CC}	V_{EE}	-	V_{CC}	V
T_{amb}	ambient temperature		-40	+25	+125	-40	+25	+125	°C
$\Delta t/\Delta V$	input transition rise and fall rate	$V_{CC} = 2.0\text{ V}$	-	-	625	-	-	-	ns/V
		$V_{CC} = 4.5\text{ V}$	-	1.67	139	-	1.67	139	ns/V
		$V_{CC} = 6.0\text{ V}$	-	-	83	-	-	-	ns/V
		$V_{CC} = 10.0\text{ V}$	-	-	31	-	-	-	ns/V

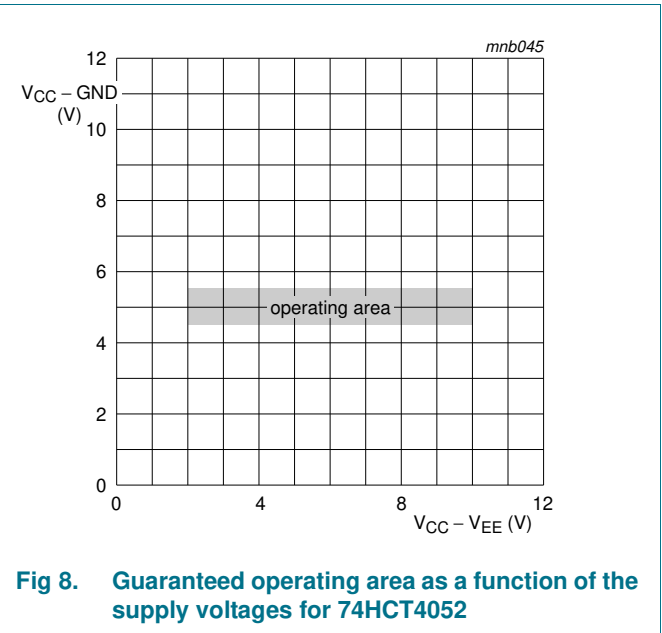
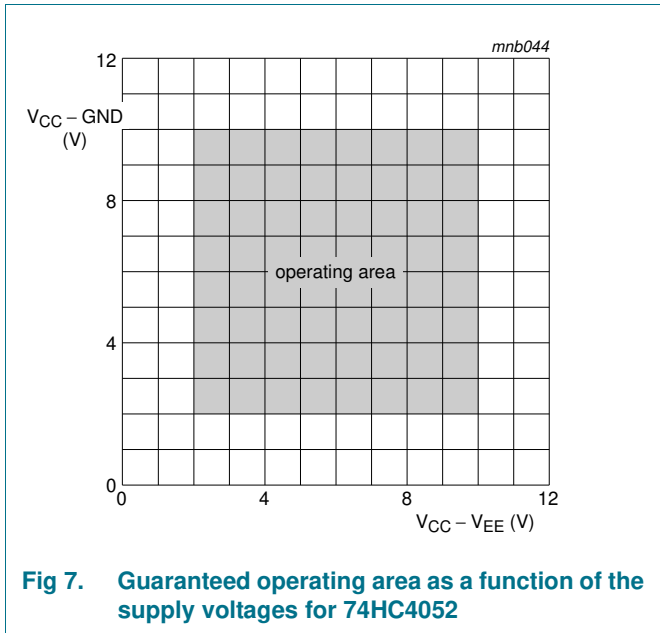

10. Static characteristics

Table 6. R_{ON} resistance per switch for 74HC4052 and 74HCT4052

V_I = V_{IH} or V_{IL}; for test circuit see Figure 9.

V_{is} is the input voltage at a nYn or nZ terminal, whichever is assigned as an input.

V_{os} is the output voltage at a nYn or nZ terminal, whichever is assigned as an output.

For 74HC4052: V_{CC} – GND or V_{CC} – V_{EE} = 2.0 V, 4.5 V, 6.0 V and 9.0 V.

For 74HCT4052: V_{CC} – GND = 4.5 V and 5.5 V, V_{CC} – V_{EE} = 2.0 V, 4.5 V, 6.0 V and 9.0 V.

Symbol	Parameter	Conditions	Min	Typ	Max	Unit
T_{amb} = –40 °C to +85 °C						
R _{ON(peak)}	ON resistance (peak)	V _{is} = V _{CC} to V _{EE}				
		V _{CC} = 2.0 V; V _{EE} = 0 V; I _{SW} = 100 μA	2	-	-	Ω
		V _{CC} = 4.5 V; V _{EE} = 0 V; I _{SW} = 1000 μA	-	100	225	Ω
		V _{CC} = 6.0 V; V _{EE} = 0 V; I _{SW} = 1000 μA	-	90	200	Ω
		V _{CC} = 4.5 V; V _{EE} = –4.5 V; I _{SW} = 1000 μA	-	70	165	Ω
R _{ON(rail)}	ON resistance (rail)	V _{is} = V _{EE}				
		V _{CC} = 2.0 V; V _{EE} = 0 V; I _{SW} = 100 μA	2	-	150	Ω
		V _{CC} = 4.5 V; V _{EE} = 0 V; I _{SW} = 1000 μA	-	80	175	Ω
		V _{CC} = 6.0 V; V _{EE} = 0 V; I _{SW} = 1000 μA	-	70	150	Ω
		V _{CC} = 4.5 V; V _{EE} = –4.5 V; I _{SW} = 1000 μA	-	60	130	Ω
		V _{is} = V _{CC}				
		V _{CC} = 2.0 V; V _{EE} = 0 V; I _{SW} = 100 μA	2	-	150	Ω
		V _{CC} = 4.5 V; V _{EE} = 0 V; I _{SW} = 1000 μA	-	90	200	Ω
		V _{CC} = 6.0 V; V _{EE} = 0 V; I _{SW} = 1000 μA	-	80	175	Ω
		V _{CC} = 4.5 V; V _{EE} = –4.5 V; I _{SW} = 1000 μA	-	65	150	Ω
ΔR _{ON}	ON resistance mismatch between channels	V _{is} = V _{CC} to V _{EE}				
		V _{CC} = 2.0 V; V _{EE} = 0 V	2	-	-	Ω
		V _{CC} = 4.5 V; V _{EE} = 0 V	-	9	-	Ω
		V _{CC} = 6.0 V; V _{EE} = 0 V	-	8	-	Ω
		V _{CC} = 4.5 V; V _{EE} = –4.5 V	-	6	-	Ω
T_{amb} = –40 °C to +125 °C						
R _{ON(peak)}	ON resistance (peak)	V _{is} = V _{CC} to V _{EE}				
		V _{CC} = 2.0 V; V _{EE} = 0 V; I _{SW} = 100 μA	2	-	-	Ω
		V _{CC} = 4.5 V; V _{EE} = 0 V; I _{SW} = 1000 μA	-	-	270	Ω
		V _{CC} = 6.0 V; V _{EE} = 0 V; I _{SW} = 1000 μA	-	-	240	Ω
		V _{CC} = 4.5 V; V _{EE} = –4.5 V; I _{SW} = 1000 μA	-	-	195	Ω

Table 6. R_{ON} resistance per switch for 74HC4052 and 74HCT4052 ...continued

V_I = V_{IH} or V_{IL}; for test circuit see Figure 9.

V_{is} is the input voltage at a nYn or nZ terminal, whichever is assigned as an input.

V_{os} is the output voltage at a nYn or nZ terminal, whichever is assigned as an output.

For 74HC4052: V_{CC} – GND or V_{CC} – V_{EE} = 2.0 V, 4.5 V, 6.0 V and 9.0 V.

For 74HCT4052: V_{CC} – GND = 4.5 V and 5.5 V, V_{CC} – V_{EE} = 2.0 V, 4.5 V, 6.0 V and 9.0 V.

Symbol	Parameter	Conditions	Min	Typ	Max	Unit	
R _{ON(rail)}	ON resistance (rail)	V _{is} = V _{EE}					
		V _{CC} = 2.0 V; V _{EE} = 0 V; I _{SW} = 100 μA	[2]	-	-	-	Ω
		V _{CC} = 4.5 V; V _{EE} = 0 V; I _{SW} = 1000 μA	-	-	210	Ω	
		V _{CC} = 6.0 V; V _{EE} = 0 V; I _{SW} = 1000 μA	-	-	180	Ω	
		V _{CC} = 4.5 V; V _{EE} = -4.5 V; I _{SW} = 1000 μA	-	-	160	Ω	
		V _{is} = V _{CC}					
		V _{CC} = 2.0 V; V _{EE} = 0 V; I _{SW} = 100 μA	[2]	-	-	-	Ω
		V _{CC} = 4.5 V; V _{EE} = 0 V; I _{SW} = 1000 μA	-	-	240	Ω	
		V _{CC} = 6.0 V; V _{EE} = 0 V; I _{SW} = 1000 μA	-	-	210	Ω	
		V _{CC} = 4.5 V; V _{EE} = -4.5 V; I _{SW} = 1000 μA	-	-	180	Ω	

[1] All typical values are measured at T_{amb} = 25 °C.

[2] When supply voltages (V_{CC} – V_{EE}) near 2.0 V the analog switch ON resistance becomes extremely non-linear. When using a supply of 2 V, it is recommended to use these devices only for transmitting digital signals.

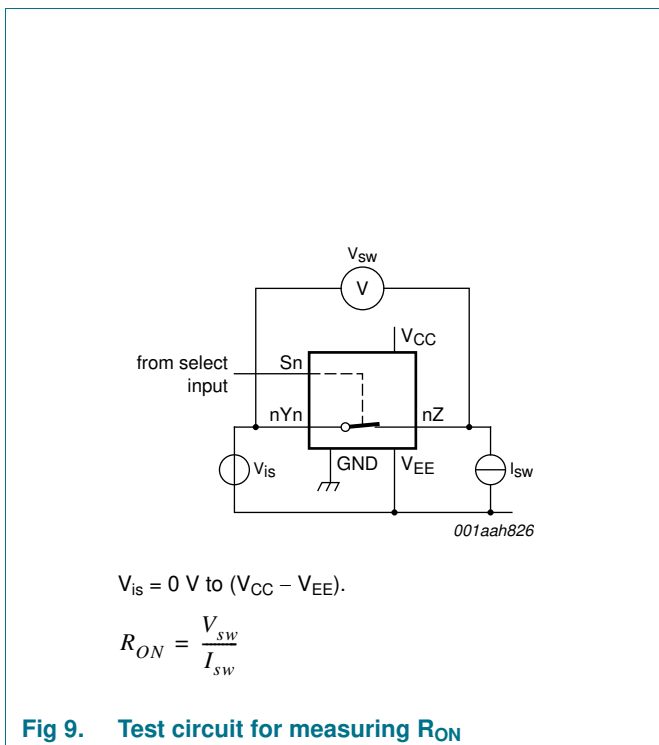

Fig 9. Test circuit for measuring R_{ON}

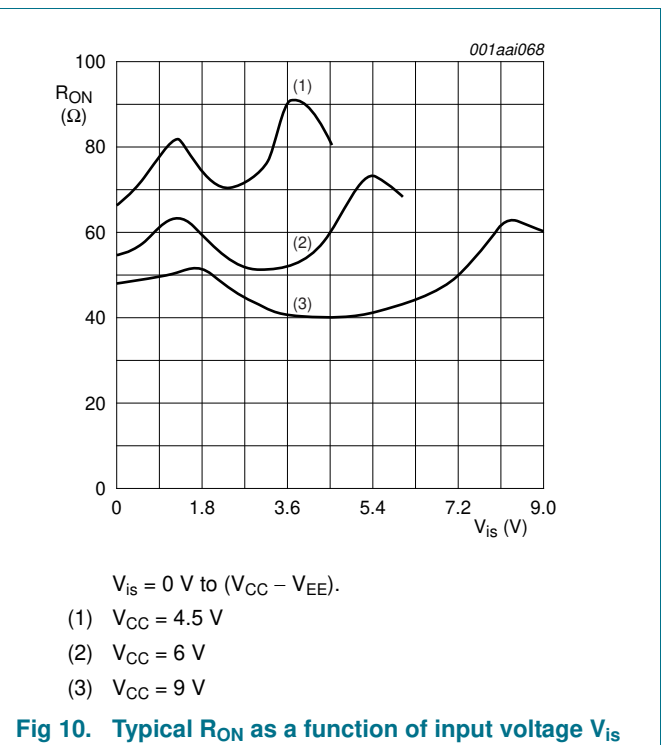

Fig 10. Typical R_{ON} as a function of input voltage V_{is}

Table 7. Static characteristics for 74HC4052

Voltages are referenced to GND (ground = 0 V).

V_{is} is the input voltage at pins nYn or nZ, whichever is assigned as an input.

V_{os} is the output voltage at pins nZ or nYn, whichever is assigned as an output.

Symbol	Parameter	Conditions	Min	Typ	Max	Unit
$T_{amb} = -40\text{ °C to }+85\text{ °C}$ [1]						
V_{IH}	HIGH-level input voltage	$V_{CC} = 2.0\text{ V}$	1.5	1.2	-	V
		$V_{CC} = 4.5\text{ V}$	3.15	2.4	-	V
		$V_{CC} = 6.0\text{ V}$	4.2	3.2	-	V
		$V_{CC} = 9.0\text{ V}$	6.3	4.7	-	V
V_{IL}	LOW-level input voltage	$V_{CC} = 2.0\text{ V}$	-	0.8	0.5	V
		$V_{CC} = 4.5\text{ V}$	-	2.1	1.35	V
		$V_{CC} = 6.0\text{ V}$	-	2.8	1.8	V
		$V_{CC} = 9.0\text{ V}$	-	4.3	2.7	V
I_I	input leakage current	$V_{EE} = 0\text{ V}; V_I = V_{CC}\text{ or GND}$				
		$V_{CC} = 6.0\text{ V}$	-	-	± 1.0	μA
		$V_{CC} = 10.0\text{ V}$	-	-	± 2.0	μA
$I_{S(OFF)}$	OFF-state leakage current	$V_{CC} = 10.0\text{ V}; V_{EE} = 0\text{ V}; V_I = V_{IH}\text{ or }V_{IL};$ $ V_{SW} = V_{CC} - V_{EE};$ see Figure 11				
		per channel	-	-	± 1.0	μA
		all channels	-	-	± 2.0	μA
$I_{S(ON)}$	ON-state leakage current	$V_I = V_{IH}\text{ or }V_{IL}; V_{SW} = V_{CC} - V_{EE};$ $V_{CC} = 10.0\text{ V}; V_{EE} = 0\text{ V};$ see Figure 12	-	-	± 2.0	μA
I_{CC}	supply current	$V_{EE} = 0\text{ V}; V_I = V_{CC}\text{ or GND}; V_{is} = V_{EE}\text{ or }V_{CC};$ $V_{os} = V_{CC}\text{ or }V_{EE}$				
		$V_{CC} = 6.0\text{ V}$	-	-	80.0	μA
		$V_{CC} = 10.0\text{ V}$	-	-	160.0	μA
C_I	input capacitance		-	3.5	-	pF
C_{SW}	switch capacitance	independent pins nYn	-	5	-	pF
		common pins nZ	-	12	-	pF
$T_{amb} = -40\text{ °C to }+125\text{ °C}$						
V_{IH}	HIGH-level input voltage	$V_{CC} = 2.0\text{ V}$	1.5	-	-	V
		$V_{CC} = 4.5\text{ V}$	3.15	-	-	V
		$V_{CC} = 6.0\text{ V}$	4.2	-	-	V
		$V_{CC} = 9.0\text{ V}$	6.3	-	-	V
V_{IL}	LOW-level input voltage	$V_{CC} = 2.0\text{ V}$	-	-	0.5	V
		$V_{CC} = 4.5\text{ V}$	-	-	1.35	V
		$V_{CC} = 6.0\text{ V}$	-	-	1.8	V
		$V_{CC} = 9.0\text{ V}$	-	-	2.7	V
I_I	input leakage current	$V_{EE} = 0\text{ V}; V_I = V_{CC}\text{ or GND}$				
		$V_{CC} = 6.0\text{ V}$	-	-	± 1.0	μA
		$V_{CC} = 10.0\text{ V}$	-	-	± 2.0	μA

Table 7. Static characteristics for 74HC4052 ...continued

Voltages are referenced to GND (ground = 0 V).

V_{is} is the input voltage at pins nYn or nZ, whichever is assigned as an input.

V_{os} is the output voltage at pins nZ or nYn, whichever is assigned as an output.

Symbol	Parameter	Conditions	Min	Typ	Max	Unit
$I_{S(OFF)}$	OFF-state leakage current	$V_{CC} = 10.0\text{ V}$; $V_{EE} = 0\text{ V}$; $V_I = V_{IH}$ or V_{IL} ; $ V_{SW} = V_{CC} - V_{EE}$; see Figure 11				
		per channel	-	-	± 1.0	μA
		all channels	-	-	± 2.0	μA
$I_{S(ON)}$	ON-state leakage current	$V_I = V_{IH}$ or V_{IL} ; $ V_{SW} = V_{CC} - V_{EE}$; $V_{CC} = 10.0\text{ V}$; $V_{EE} = 0\text{ V}$; see Figure 12	-	-	± 2.0	μA
I_{CC}	supply current	$V_{EE} = 0\text{ V}$; $V_I = V_{CC}$ or GND; $V_{is} = V_{EE}$ or V_{CC} ; $V_{os} = V_{CC}$ or V_{EE}				
		$V_{CC} = 6.0\text{ V}$	-	-	160.0	μA
		$V_{CC} = 10.0\text{ V}$	-	-	320.0	μA

[1] All typical values are measured at $T_{amb} = 25\text{ }^\circ\text{C}$.

Table 8. Static characteristics for 74HCT4052

Voltages are referenced to GND (ground = 0 V).

V_{is} is the input voltage at pins nYn or nZ, whichever is assigned as an input.

V_{os} is the output voltage at pins nZ or nYn, whichever is assigned as an output.

Symbol	Parameter	Conditions	Min	Typ	Max	Unit
$T_{amb} = -40\text{ }^\circ\text{C}$ to $+85\text{ }^\circ\text{C}$[1]						
V_{IH}	HIGH-level input voltage	$V_{CC} = 4.5\text{ V}$ to 5.5 V	2.0	1.6	-	V
V_{IL}	LOW-level input voltage	$V_{CC} = 4.5\text{ V}$ to 5.5 V	-	1.2	0.8	V
I_I	input leakage current	$V_I = V_{CC}$ or GND; $V_{CC} = 5.5\text{ V}$; $V_{EE} = 0\text{ V}$	-	-	± 1.0	μA
$I_{S(OFF)}$	OFF-state leakage current	$V_{CC} = 10.0\text{ V}$; $V_{EE} = 0\text{ V}$; $V_I = V_{IH}$ or V_{IL} ; $ V_{SW} = V_{CC} - V_{EE}$; see Figure 11				
		per channel	-	-	± 1.0	μA
		all channels	-	-	± 2.0	μA
$I_{S(ON)}$	ON-state leakage current	$V_{CC} = 10.0\text{ V}$; $V_{EE} = 0\text{ V}$; $V_I = V_{IH}$ or V_{IL} ; $ V_{SW} = V_{CC} - V_{EE}$; see Figure 12	-	-	± 2.0	μA
I_{CC}	supply current	$V_I = V_{CC}$ or GND; $V_{is} = V_{EE}$ or V_{CC} ; $V_{os} = V_{CC}$ or V_{EE}				
		$V_{CC} = 5.5\text{ V}$; $V_{EE} = 0\text{ V}$	-	-	80.0	μA
		$V_{CC} = 5.0\text{ V}$; $V_{EE} = -5.0\text{ V}$	-	-	160.0	μA
ΔI_{CC}	additional supply current	per input; $V_I = V_{CC} - 2.1\text{ V}$; other inputs at V_{CC} or GND; $V_{CC} = 4.5\text{ V}$ to 5.5 V ; $V_{EE} = 0\text{ V}$	-	45	202.5	μA
C_I	input capacitance		-	3.5	-	pF
C_{SW}	switch capacitance	independent pins nYn	-	5	-	pF
		common pins nZ	-	12	-	pF
$T_{amb} = -40\text{ }^\circ\text{C}$ to $+125\text{ }^\circ\text{C}$						
V_{IH}	HIGH-level input voltage	$V_{CC} = 4.5\text{ V}$ to 5.5 V	2.0	-	-	V

Table 8. Static characteristics for 74HCT4052 ...continued

Voltages are referenced to GND (ground = 0 V).

V_{is} is the input voltage at pins nYn or nZ , whichever is assigned as an input.

V_{os} is the output voltage at pins nZ or nYn , whichever is assigned as an output.

Symbol	Parameter	Conditions	Min	Typ	Max	Unit
V_{IL}	LOW-level input voltage	$V_{CC} = 4.5 \text{ V to } 5.5 \text{ V}$	-	-	0.8	V
I_I	input leakage current	$V_I = V_{CC} \text{ or } \text{GND}; V_{CC} = 5.5 \text{ V}; V_{EE} = 0 \text{ V}$	-	-	± 1.0	μA
$I_{S(\text{OFF})}$	OFF-state leakage current	$V_{CC} = 10.0 \text{ V}; V_{EE} = 0 \text{ V}; V_I = V_{IH} \text{ or } V_{IL}; V_{SW} = V_{CC} - V_{EE};$ see Figure 11	-	-	± 1.0	μA
		per channel	-	-	± 1.0	μA
		all channels	-	-	± 2.0	μA
$I_{S(\text{ON})}$	ON-state leakage current	$V_{CC} = 10.0 \text{ V}; V_{EE} = 0 \text{ V}; V_I = V_{IH} \text{ or } V_{IL}; V_{SW} = V_{CC} - V_{EE};$ see Figure 12	-	-	± 2.0	μA
I_{CC}	supply current	$V_I = V_{CC} \text{ or } \text{GND}; V_{is} = V_{EE} \text{ or } V_{CC}; V_{os} = V_{CC} \text{ or } V_{EE}$	-	-	-	-
		$V_{CC} = 5.5 \text{ V}; V_{EE} = 0 \text{ V}$	-	-	160.0	μA
		$V_{CC} = 5.0 \text{ V}; V_{EE} = -5.0 \text{ V}$	-	-	320.0	μA
ΔI_{CC}	additional supply current	per input; $V_I = V_{CC} - 2.1 \text{ V};$ other inputs at V_{CC} or $\text{GND}; V_{CC} = 4.5 \text{ V to } 5.5 \text{ V}; V_{EE} = 0 \text{ V}$	-	-	220.5	μA

[1] All typical values are measured at $T_{amb} = 25 \text{ }^\circ\text{C}$.

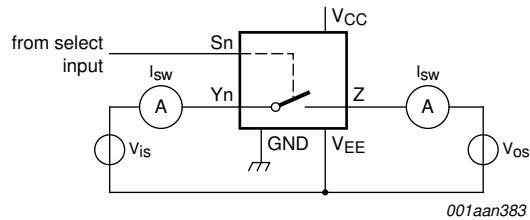

001aan383

$V_{is} = V_{CC}$ and $V_{os} = V_{EE}$.

$V_{is} = V_{EE}$ and $V_{os} = V_{CC}$.

Fig 11. Test circuit for measuring OFF-state current

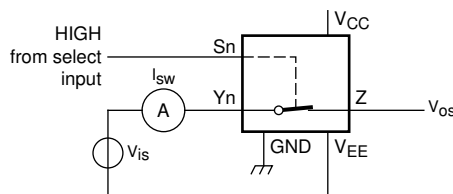

001aan384

$V_{is} = V_{CC}$ and $V_{os} = \text{open-circuit}$.

$V_{is} = V_{EE}$ and $V_{os} = \text{open-circuit}$.

Fig 12. Test circuit for measuring ON-state current

11. Dynamic characteristics

Table 9. Dynamic characteristics for 74HC4052

$GND = 0\text{ V}$; $t_r = t_f = 6\text{ ns}$; $C_L = 50\text{ pF}$; for test circuit see [Figure 15](#).

V_{is} is the input voltage at a nYn or nZ terminal, whichever is assigned as an input.

V_{os} is the output voltage at a nYn or nZ terminal, whichever is assigned as an output.

Symbol	Parameter	Conditions	Min	Typ	Max	Unit		
$T_{amb} = -40\text{ °C to }+85\text{ °C}$[1]								
t_{pd}	propagation delay	V_{is} to V_{os} ; $R_L = \infty\ \Omega$; see Figure 13	[2]					
		$V_{CC} = 2.0\text{ V}$; $V_{EE} = 0\text{ V}$	-	14	75	ns		
		$V_{CC} = 4.5\text{ V}$; $V_{EE} = 0\text{ V}$	-	5	15	ns		
		$V_{CC} = 6.0\text{ V}$; $V_{EE} = 0\text{ V}$	-	4	13	ns		
t_{on}	turn-on time	\bar{E} , Sn to V_{os} ; $R_L = \infty\ \Omega$; see Figure 14	[3]					
		$V_{CC} = 2.0\text{ V}$; $V_{EE} = 0\text{ V}$	-	105	405	ns		
		$V_{CC} = 4.5\text{ V}$; $V_{EE} = 0\text{ V}$	-	38	81	ns		
		$V_{CC} = 5.0\text{ V}$; $V_{EE} = 0\text{ V}$; $C_L = 15\text{ pF}$	-	28	-	ns		
		$V_{CC} = 6.0\text{ V}$; $V_{EE} = 0\text{ V}$	-	30	69	ns		
t_{off}	turn-off time	\bar{E} , Sn to V_{os} ; $R_L = 1\text{ k}\Omega$; see Figure 14	[4]					
		$V_{CC} = 2.0\text{ V}$; $V_{EE} = 0\text{ V}$	-	74	315	ns		
		$V_{CC} = 4.5\text{ V}$; $V_{EE} = 0\text{ V}$	-	27	63	ns		
		$V_{CC} = 5.0\text{ V}$; $V_{EE} = 0\text{ V}$; $C_L = 15\text{ pF}$	-	21	-	ns		
		$V_{CC} = 6.0\text{ V}$; $V_{EE} = 0\text{ V}$	-	22	54	ns		
C_{PD}	power dissipation capacitance	per switch; $V_I = GND$ to V_{CC}	[5]	-	57	-	pF	
		$T_{amb} = -40\text{ °C to }+125\text{ °C}$						
		t_{pd}	propagation delay	V_{is} to V_{os} ; $R_L = \infty\ \Omega$; see Figure 13	[2]			
				$V_{CC} = 2.0\text{ V}$; $V_{EE} = 0\text{ V}$	-	-	90	ns
				$V_{CC} = 4.5\text{ V}$; $V_{EE} = 0\text{ V}$	-	-	18	ns
$V_{CC} = 6.0\text{ V}$; $V_{EE} = 0\text{ V}$	-			-	15	ns		
t_{on}	turn-on time	\bar{E} , Sn to V_{os} ; $R_L = \infty\ \Omega$; see Figure 14	[3]					
		$V_{CC} = 2.0\text{ V}$; $V_{EE} = 0\text{ V}$	-	-	490	ns		
		$V_{CC} = 4.5\text{ V}$; $V_{EE} = 0\text{ V}$	-	-	98	ns		
		$V_{CC} = 6.0\text{ V}$; $V_{EE} = 0\text{ V}$	-	-	83	ns		
		$V_{CC} = 4.5\text{ V}$; $V_{EE} = -4.5\text{ V}$	-	-	69	ns		

Table 9. Dynamic characteristics for 74HC4052 ...continued

$GND = 0\text{ V}$; $t_r = t_f = 6\text{ ns}$; $C_L = 50\text{ pF}$; for test circuit see [Figure 15](#).

V_{is} is the input voltage at a nYn or nZ terminal, whichever is assigned as an input.

V_{os} is the output voltage at a nYn or nZ terminal, whichever is assigned as an output.

Symbol	Parameter	Conditions	Min	Typ	Max	Unit
t_{off}	turn-off time	\bar{E} , Sn to V_{os} ; $R_L = 1\text{ k}\Omega$; see Figure 14	[4]			
		$V_{CC} = 2.0\text{ V}$; $V_{EE} = 0\text{ V}$	-	-	375	ns
		$V_{CC} = 4.5\text{ V}$; $V_{EE} = 0\text{ V}$	-	-	75	ns
		$V_{CC} = 6.0\text{ V}$; $V_{EE} = 0\text{ V}$	-	-	64	ns
		$V_{CC} = 4.5\text{ V}$; $V_{EE} = -4.5\text{ V}$	-	-	57	ns

- [1] All typical values are measured at $T_{amb} = 25\text{ }^\circ\text{C}$.
- [2] t_{pd} is the same as t_{PHL} and t_{PLH} .
- [3] t_{on} is the same as t_{PZH} and t_{PZL} .
- [4] t_{off} is the same as t_{PHZ} and t_{PLZ} .
- [5] C_{PD} is used to determine the dynamic power dissipation (P_D in μW).
 $P_D = C_{PD} \times V_{CC}^2 \times f_i \times N + \Sigma\{(C_L + C_{sw}) \times V_{CC}^2 \times f_o\}$ where:
 f_i = input frequency in MHz;
 f_o = output frequency in MHz;
 N = number of inputs switching;
 $\Sigma\{(C_L + C_{sw}) \times V_{CC}^2 \times f_o\}$ = sum of outputs;
 C_L = output load capacitance in pF;
 C_{sw} = switch capacitance in pF;
 V_{CC} = supply voltage in V.

Table 10. Dynamic characteristics for 74HCT4052

$GND = 0\text{ V}$; $t_r = t_f = 6\text{ ns}$; $C_L = 50\text{ pF}$; for test circuit see [Figure 15](#).

V_{is} is the input voltage at a nYn or nZ terminal, whichever is assigned as an input.

V_{os} is the output voltage at a nYn or nZ terminal, whichever is assigned as an output.

Symbol	Parameter	Conditions	Min	Typ	Max	Unit
$T_{amb} = -40\text{ }^\circ\text{C to } +85\text{ }^\circ\text{C}$[1]						
t_{pd}	propagation delay	V_{is} to V_{os} ; $R_L = \infty\ \Omega$; see Figure 13	[2]			
		$V_{CC} = 4.5\text{ V}$; $V_{EE} = 0\text{ V}$	-	5	15	ns
		$V_{CC} = 4.5\text{ V}$; $V_{EE} = -4.5\text{ V}$	-	4	10	ns
t_{on}	turn-on time	\bar{E} , Sn to V_{os} ; $R_L = 1\text{ k}\Omega$; see Figure 14	[3]			
		$V_{CC} = 4.5\text{ V}$; $V_{EE} = 0\text{ V}$	-	41	88	ns
		$V_{CC} = 5.0\text{ V}$; $V_{EE} = 0\text{ V}$; $C_L = 15\text{ pF}$	-	18	-	ns
		$V_{CC} = 4.5\text{ V}$; $V_{EE} = -4.5\text{ V}$	-	28	60	ns
t_{off}	turn-off time	\bar{E} , Sn to V_{os} ; $R_L = 1\text{ k}\Omega$; see Figure 14	[4]			
		$V_{CC} = 4.5\text{ V}$; $V_{EE} = 0\text{ V}$	-	26	63	ns
		$V_{CC} = 5.0\text{ V}$; $V_{EE} = 0\text{ V}$; $C_L = 15\text{ pF}$	-	13	-	ns
		$V_{CC} = 4.5\text{ V}$; $V_{EE} = -4.5\text{ V}$	-	21	48	ns
C_{PD}	power dissipation capacitance	per switch; $V_I = GND$ to $V_{CC} - 1.5\text{ V}$	[5]	57	-	pF

Table 10. Dynamic characteristics for 74HCT4052 ...continued

$GND = 0\text{ V}$; $t_r = t_f = 6\text{ ns}$; $C_L = 50\text{ pF}$; for test circuit see [Figure 15](#).

V_{is} is the input voltage at a nYn or nZ terminal, whichever is assigned as an input.

V_{os} is the output voltage at a nYn or nZ terminal, whichever is assigned as an output.

Symbol	Parameter	Conditions	Min	Typ	Max	Unit
$T_{amb} = -40\text{ °C to }+125\text{ °C}$						
t_{pd}	propagation delay	V_{is} to V_{os} ; $R_L = \infty\ \Omega$; see Figure 13	[2]			
		$V_{CC} = 4.5\text{ V}$; $V_{EE} = 0\text{ V}$	-	-	18	ns
		$V_{CC} = 4.5\text{ V}$; $V_{EE} = -4.5\text{ V}$	-	-	12	ns
t_{on}	turn-on time	\bar{E} , Sn to V_{os} ; $R_L = 1\text{ k}\Omega$; see Figure 14	[3]			
		$V_{CC} = 4.5\text{ V}$; $V_{EE} = 0\text{ V}$	-	-	105	ns
		$V_{CC} = 4.5\text{ V}$; $V_{EE} = -4.5\text{ V}$	-	-	72	ns
t_{off}	turn-off time	\bar{E} , Sn to V_{os} ; $R_L = 1\text{ k}\Omega$; see Figure 14	[4]			
		$V_{CC} = 4.5\text{ V}$; $V_{EE} = 0\text{ V}$	-	-	75	ns
		$V_{CC} = 4.5\text{ V}$; $V_{EE} = -4.5\text{ V}$	-	-	57	ns

- [1] All typical values are measured at $T_{amb} = 25\text{ °C}$.
- [2] t_{pd} is the same as t_{PHL} and t_{PLH} .
- [3] t_{on} is the same as t_{PZH} and t_{PZL} .
- [4] t_{off} is the same as t_{PHZ} and t_{PLZ} .
- [5] C_{PD} is used to determine the dynamic power dissipation (P_D in μW).
 $P_D = C_{PD} \times V_{CC}^2 \times f_i \times N + \Sigma\{(C_L + C_{sw}) \times V_{CC}^2 \times f_o\}$ where:
 f_i = input frequency in MHz;
 f_o = output frequency in MHz;
 N = number of inputs switching;
 $\Sigma\{(C_L + C_{sw}) \times V_{CC}^2 \times f_o\}$ = sum of outputs;
 C_L = output load capacitance in pF;
 C_{sw} = switch capacitance in pF;
 V_{CC} = supply voltage in V.

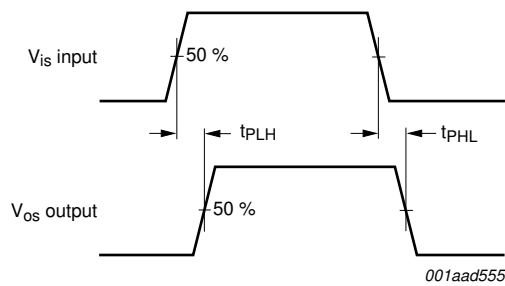
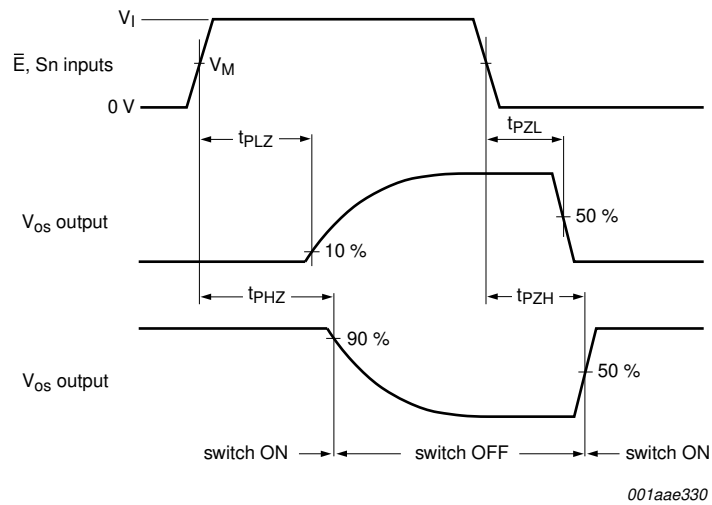
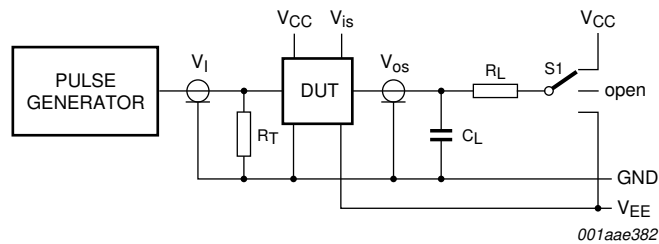
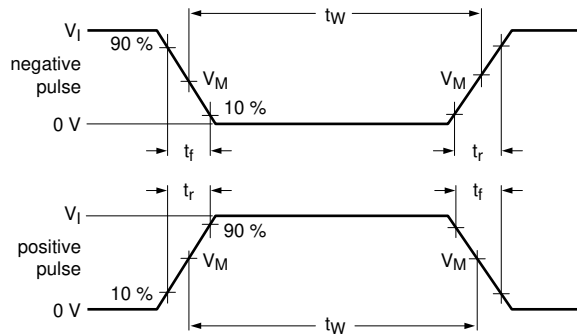

Fig 13. Input (V_{is}) to output (V_{os}) propagation delays



For 74HC4052: $V_M = 0.5 \times V_{CC}$.
 For 74HCT4052: $V_M = 1.3 \text{ V}$.

Fig 14. Turn-on and turn-off times



Definitions for test circuit; see [Table 11](#):

R_T = termination resistance should be equal to the output impedance Z_o of the pulse generator.

C_L = load capacitance including jig and probe capacitance.

R_L = load resistance.

S1 = Test selection switch.

Fig 15. Test circuit for measuring AC performance

Table 11. Test data

Test	Input				Load		S1 position
	V _I	V _{is}	t _r , t _f		C _L	R _L	
			at f _{max}	other ^[1]			
t _{PHL} , t _{PLH}	[2]	pulse	< 2 ns	6 ns	50 pF	1 kΩ	open
t _{PZH} , t _{PHZ}	[2]	V _{CC}	< 2 ns	6 ns	50 pF	1 kΩ	V _{EE}
t _{PZL} , t _{PLZ}	[2]	V _{EE}	< 2 ns	6 ns	50 pF	1 kΩ	V _{CC}

[1] t_r = t_f = 6 ns; when measuring f_{max}, there is no constraint to t_r and t_f with 50 % duty factor.

[2] V_I values:

- a) For 74HC4052: V_I = V_{CC}
- b) For 74HCT4052: V_I = 3 V

12. Additional dynamic characteristics

Table 12. Additional dynamic characteristics

Recommended conditions and typical values; GND = 0 V; T_{amb} = 25 °C; C_L = 50 pF.

V_{is} is the input voltage at pins nYn or nZ, whichever is assigned as an input.

V_{os} is the output voltage at pins nYn or nZ, whichever is assigned as an output.

Symbol	Parameter	Conditions	Min	Typ	Max	Unit	
d _{sin}	sine-wave distortion	f _i = 1 kHz; R _L = 10 kΩ; see Figure 16					
		V _{is} = 4.0 V (p-p); V _{CC} = 2.25 V; V _{EE} = -2.25 V	-	0.04	-	%	
		V _{is} = 8.0 V (p-p); V _{CC} = 4.5 V; V _{EE} = -4.5 V	-	0.02	-	%	
		f _i = 10 kHz; R _L = 10 kΩ; see Figure 16					
		V _{is} = 4.0 V (p-p); V _{CC} = 2.25 V; V _{EE} = -2.25 V	-	0.12	-	%	
		V _{is} = 8.0 V (p-p); V _{CC} = 4.5 V; V _{EE} = -4.5 V	-	0.06	-	%	
α _{iso}	isolation (OFF-state)	R _L = 600 Ω; f _i = 1 MHz; see Figure 17					
		V _{CC} = 2.25 V; V _{EE} = -2.25 V	[1]	-	-50	-	dB
		V _{CC} = 4.5 V; V _{EE} = -4.5 V	[1]	-	-50	-	dB
Xtalk	crosstalk	between two switches/multiplexers; R _L = 600 Ω; f _i = 1 MHz; see Figure 18					
		V _{CC} = 2.25 V; V _{EE} = -2.25 V	[1]	-	-60	-	dB
		V _{CC} = 4.5 V; V _{EE} = -4.5 V	[1]	-	-60	-	dB
V _{ct}	crosstalk voltage	peak-to-peak value; between control and any switch; R _L = 600 Ω; f _i = 1 MHz; E or Sn square wave between V _{CC} and GND; t _r = t _f = 6 ns; see Figure 19					
		V _{CC} = 4.5 V; V _{EE} = 0 V	-	110	-	mV	
		V _{CC} = 4.5 V; V _{EE} = -4.5 V	-	220	-	mV	
f _(-3dB)	-3 dB frequency response	R _L = 50 Ω; see Figure 20					
		V _{CC} = 2.25 V; V _{EE} = -2.25 V	[2]	-	170	-	MHz
		V _{CC} = 4.5 V; V _{EE} = -4.5 V	[2]	-	180	-	MHz

[1] Adjust input voltage V_{is} to 0 dBm level (0 dBm = 1 mW into 600 Ω).

[2] Adjust input voltage V_{is} to 0 dBm level at V_{os} for 1 MHz (0 dBm = 1 mW into 50 Ω).

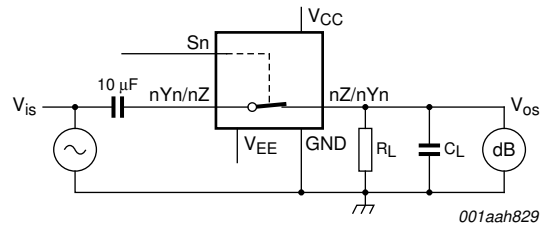
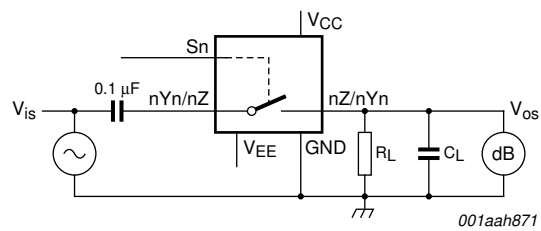
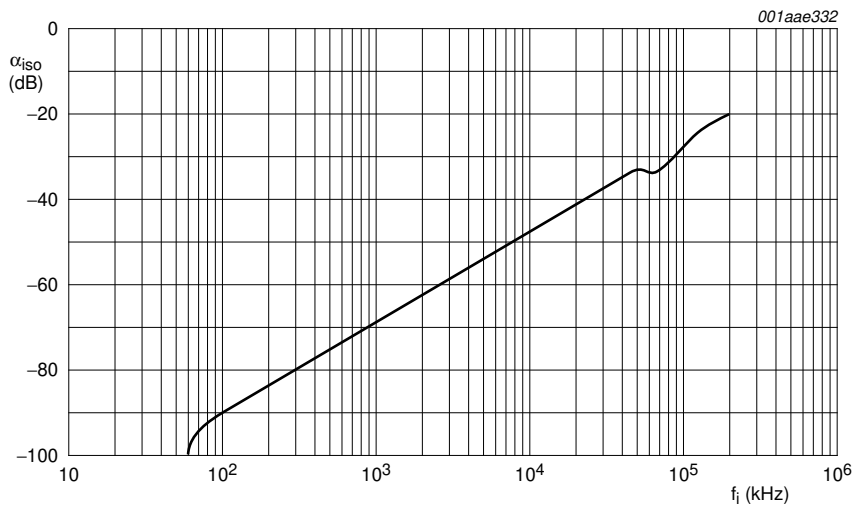

Fig 16. Test circuit for measuring sine-wave distortion



$V_{CC} = 4.5\text{ V}$; $GND = 0\text{ V}$; $V_{EE} = -4.5\text{ V}$; $R_L = 600\ \Omega$; $R_S = 1\text{ k}\Omega$.

a. Test circuit



b. Isolation (OFF-state) as a function of frequency

Fig 17. Test circuit for measuring isolation (OFF-state)

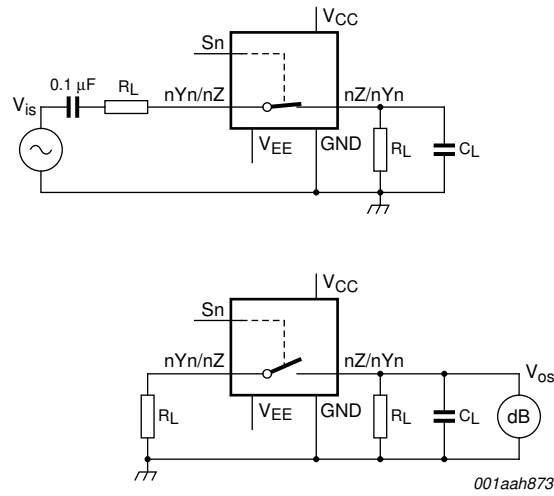

Fig 18. Test circuits for measuring crosstalk between any two switches/multiplexers

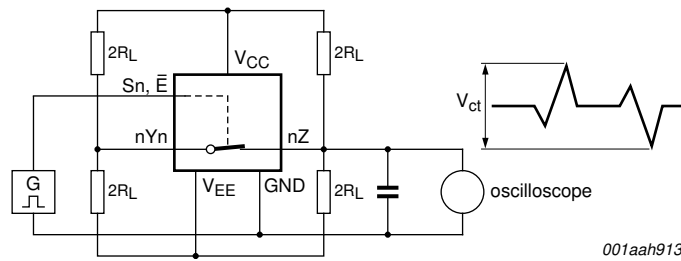
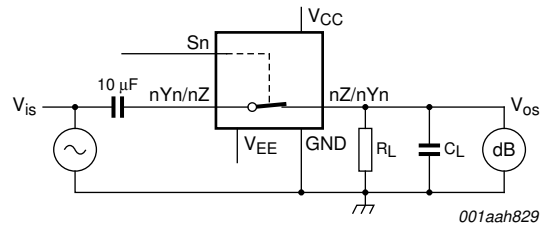
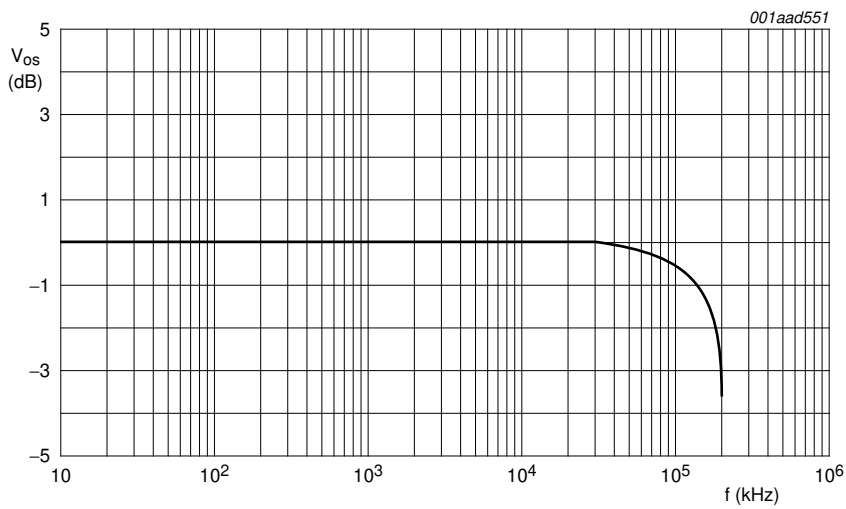

Fig 19. Test circuit for measuring crosstalk between control input and any switch



$V_{CC} = 4.5\text{ V}$; $GND = 0\text{ V}$; $V_{EE} = -4.5\text{ V}$; $R_L = 50\ \Omega$; $R_S = 1\text{ k}\Omega$.

a. Test circuit



b. Typical frequency response

Fig 20. Test circuit for frequency response

13. Package outline

SO16: plastic small outline package; 16 leads; body width 3.9 mm

SOT109-1

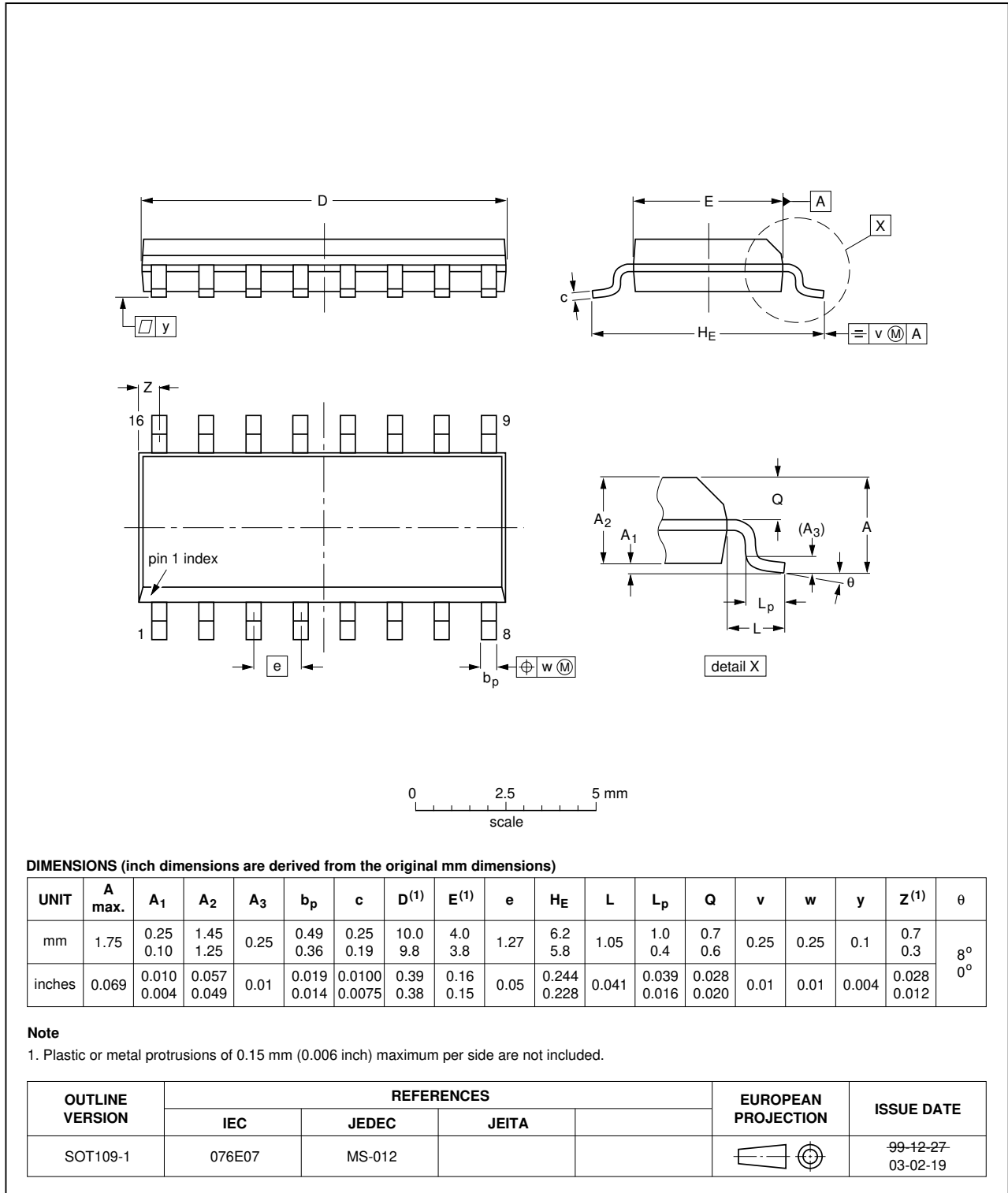

Fig 21. Package outline SOT109-1 (SO16)

SSOP16: plastic shrink small outline package; 16 leads; body width 5.3 mm

SOT338-1

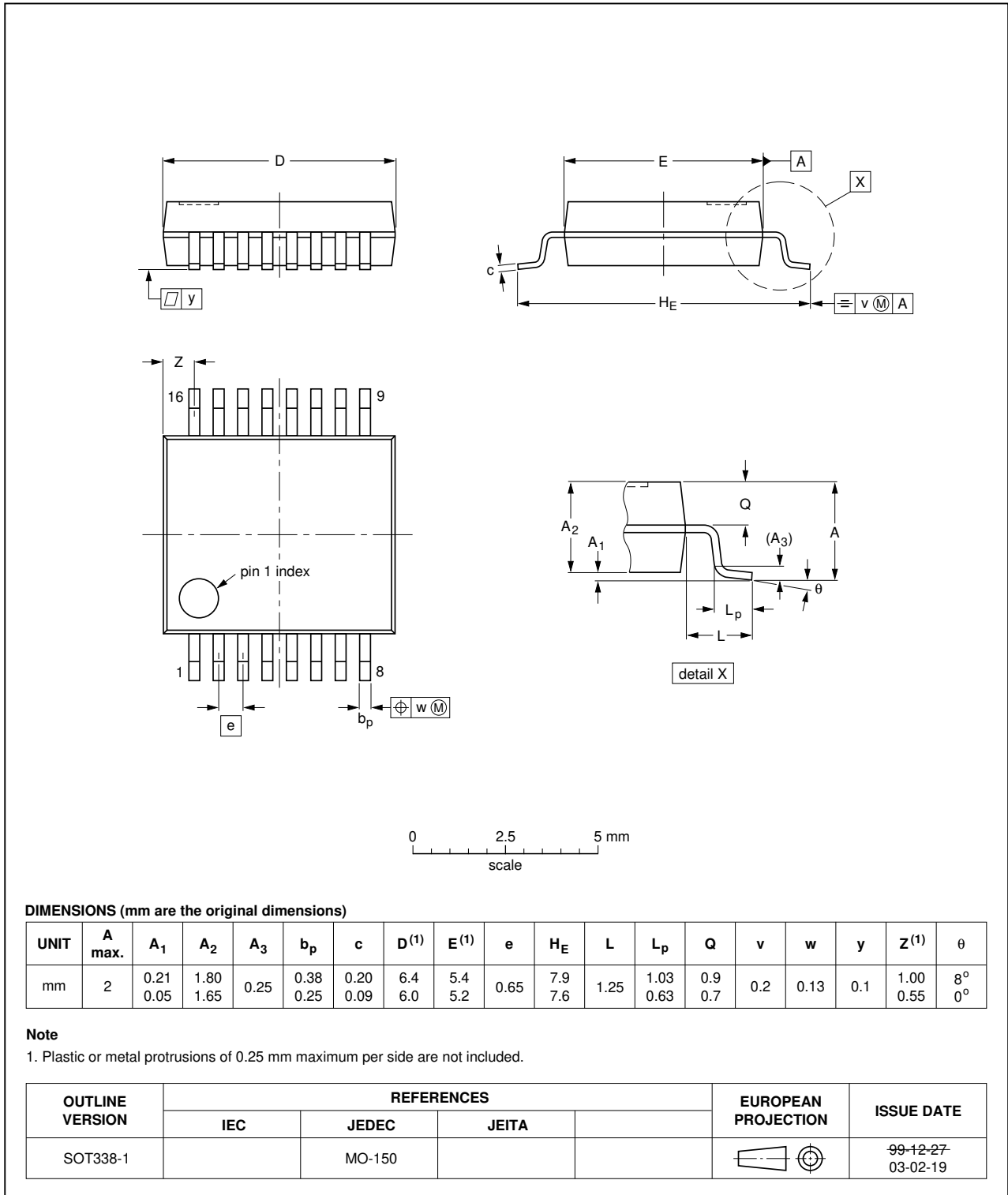

Fig 22. Package outline SOT338-1 (SSOP16)

DIP16: plastic dual in-line package; 16 leads (300 mil)

SOT38-4

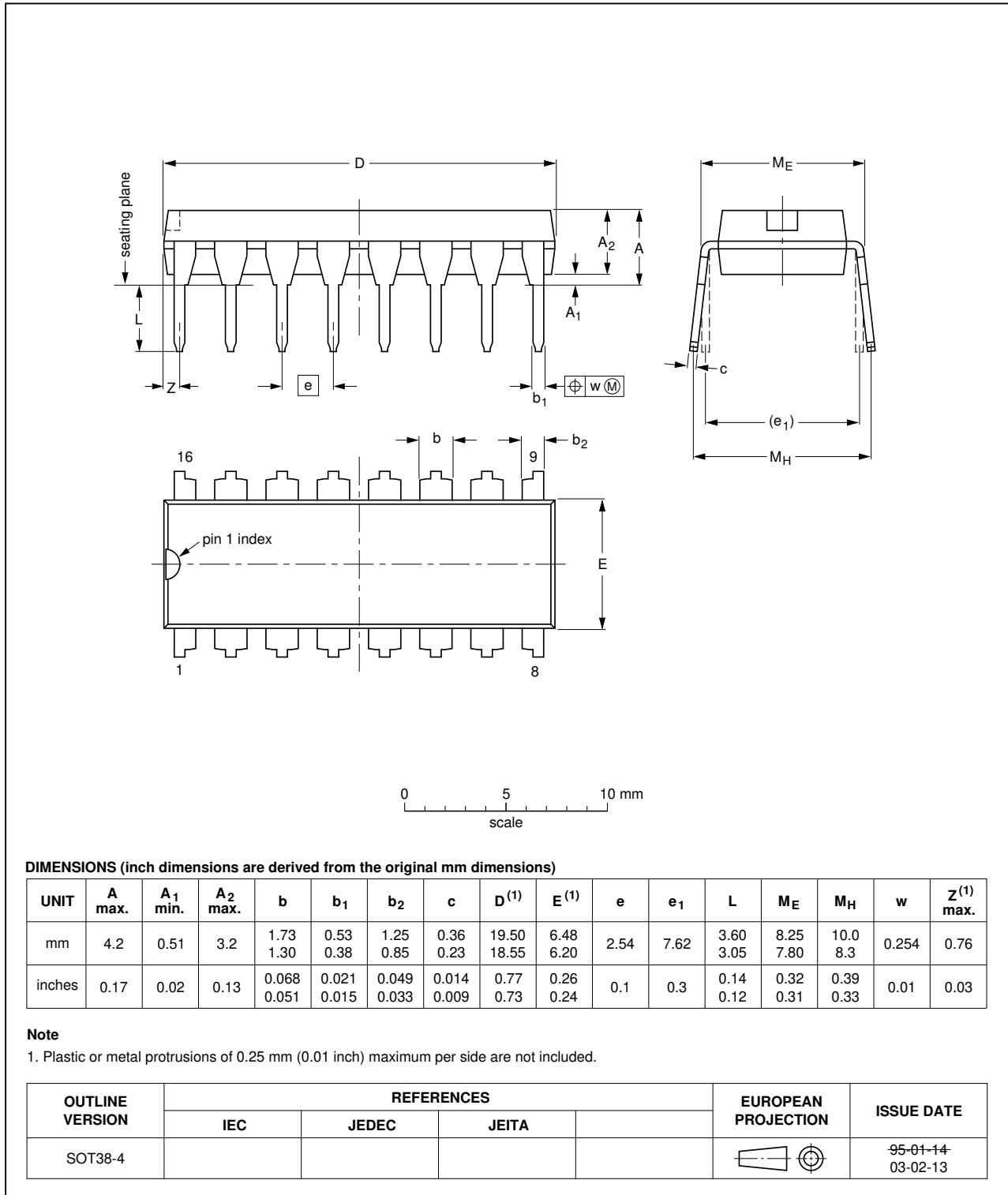

Fig 23. Package outline SOT38-4 (DIP16)

TSSOP16: plastic thin shrink small outline package; 16 leads; body width 4.4 mm

SOT403-1

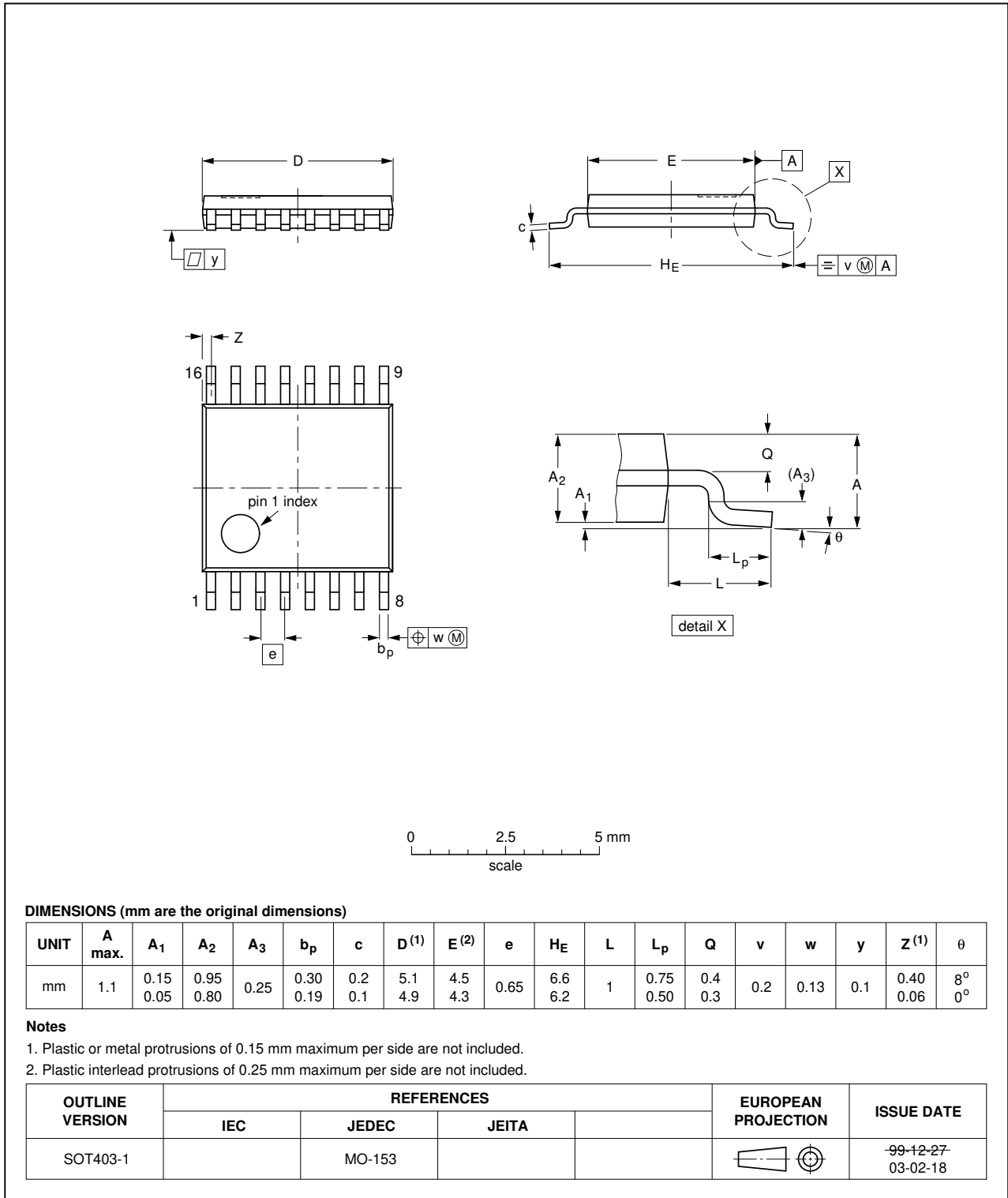

Fig 24. Package outline SOT403-1 (TSSOP16)

DHVQFN16: plastic dual in-line compatible thermal enhanced very thin quad flat package; no leads; 16 terminals; body 2.5 x 3.5 x 0.85 mm

SOT763-1

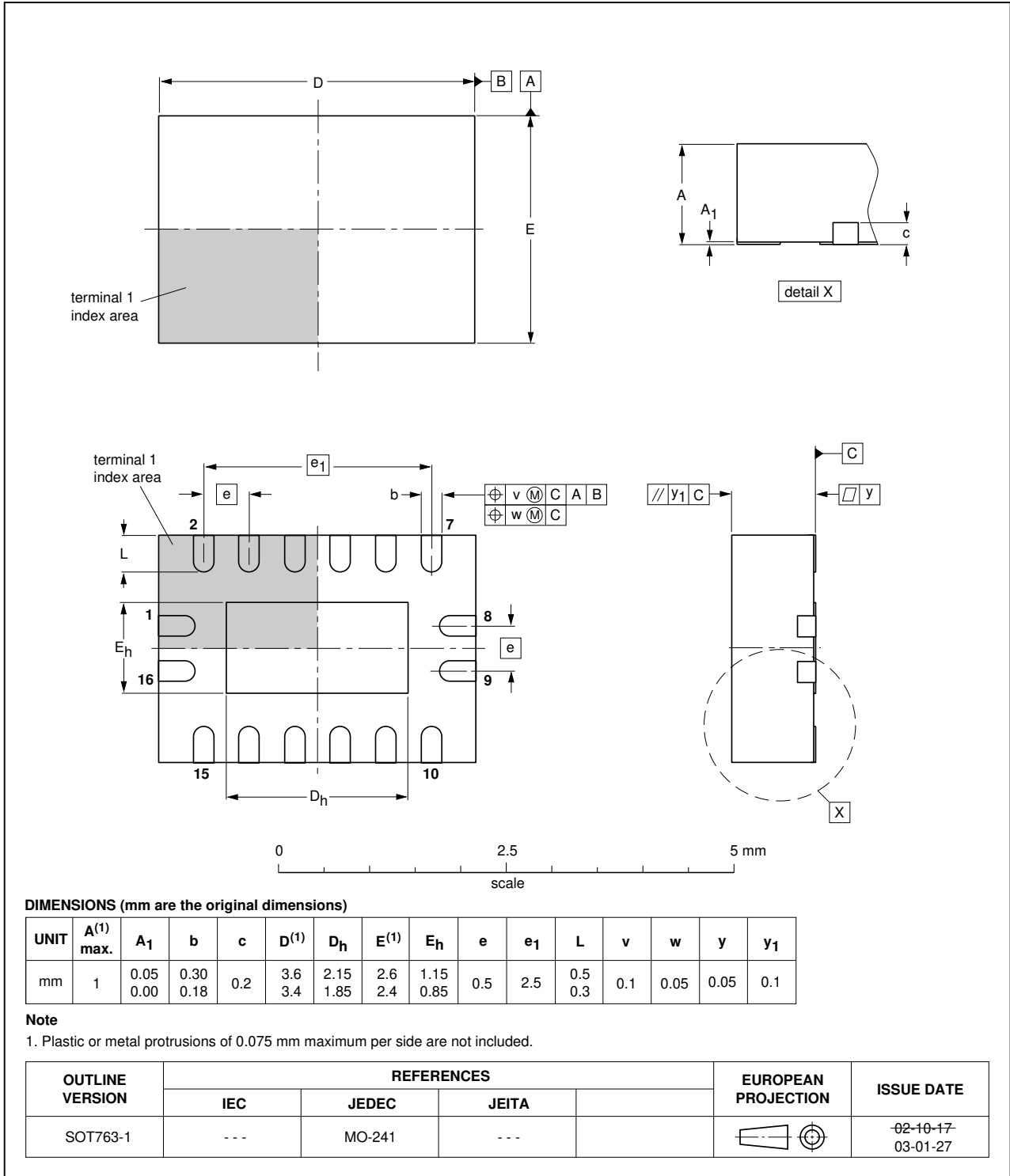

Fig 25. Package outline SOT763-1 (DHVQFN16)