



Chipsmall Limited consists of a professional team with an average of over 10 year of expertise in the distribution of electronic components. Based in Hongkong, we have already established firm and mutual-benefit business relationships with customers from,Europe,America and south Asia,supplying obsolete and hard-to-find components to meet their specific needs.

With the principle of “Quality Parts,Customers Priority,Honest Operation,and Considerate Service”,our business mainly focus on the distribution of electronic components. Line cards we deal with include Microchip,ALPS,ROHM,Xilinx,Pulse,ON,Everlight and Freescale. Main products comprise IC,Modules,Potentiometer,IC Socket,Relay,Connector.Our parts cover such applications as commercial,industrial, and automotives areas.

We are looking forward to setting up business relationship with you and hope to provide you with the best service and solution. Let us make a better world for our industry!



Contact us

Tel: +86-755-8981 8866 Fax: +86-755-8427 6832

Email & Skype: info@chipsmall.com Web: www.chipsmall.com

Address: A1208, Overseas Decoration Building, #122 Zhenhua RD., Futian, Shenzhen, China



74LVC07A

Low-Voltage CMOS Hex Buffer with Open Drain Outputs

With 5 V – Tolerant Inputs

The 74LVC07A is a high performance hex buffer operating from a 1.2 V to 5.5 V supply. High impedance TTL compatible inputs significantly reduce current loading to input drivers. These LVC devices have open drain outputs which provide the ability to set output levels, or do active-HIGH AND or active-LOW OR functions. A V_I specification of 5.5 V allows 74LVC07A inputs to be safely driven from 5.0 V devices.

Features

- Designed for 1.2 V to 5.5 V V_{CC} Operation
- 5.0 V Tolerant Inputs/Outputs
- LVTTTL Compatible
- LVCMOS Compatible
- 24 mA Output Sink Capability
- Near Zero Static Supply Current (10 μ A) Substantially Reduces System Power Requirements
- Latchup Performance Exceeds 250 mA
- Wired-OR, Wired-AND
- Output Level Can Be Set Externally Without Affecting Speed of Device
- ESD Performance: Human Body Model >2000 V;
Machine Model >200 V
- These Devices are Pb-Free, Halogen Free/BFR Free and are RoHS Compliant

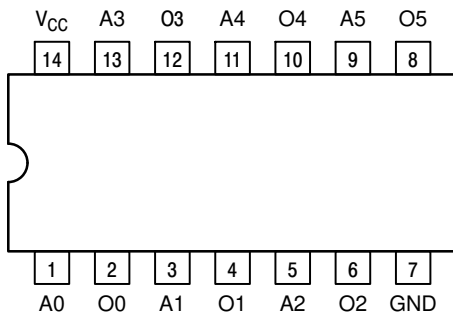

Figure 1. Pinout: 14-Lead (Top View)



ON Semiconductor®

www.onsemi.com

MARKING DIAGRAMS

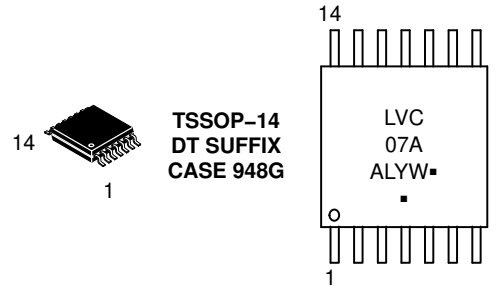
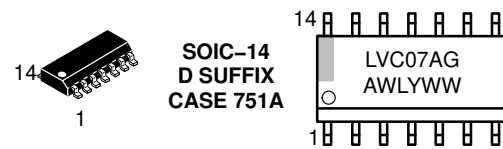

A = Assembly Location
 WL, L = Wafer Lot
 Y = Year
 WW, W = Work Week
 G or ■ = Pb-Free Package

(Note: Microdot may be in either location)

ORDERING INFORMATION

See detailed ordering and shipping information in the package dimensions section on page 2 of this data sheet.

74LVC07A

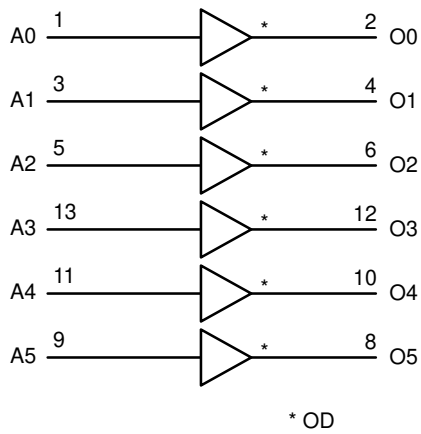

Figure 2. Logic Diagram

Table 1. PIN NAMES

Pins	Function
An	Data Inputs
On	Outputs

Table 2. TRUTH TABLE

An	On
L	L
H	Z

MAXIMUM RATINGS

Symbol	Parameter	Value	Condition	Unit
V_{CC}	DC Supply Voltage	-0.5 to +6.5		V
V_I	DC Input Voltage	$-0.5 \leq V_I \leq +6.5$		V
V_O	DC Output Voltage	$-0.5 \leq V_O \leq +6.5$	Output in 3-State	V
		$-0.5 \leq V_O \leq V_{CC} + 0.5$	Output in HIGH or LOW State (Note 1)	
I_{IK}	DC Input Diode Current	-50	$V_I < GND$	mA
I_{OK}	DC Output Diode Current	-50	$V_O < GND$	mA
		+50	$V_O > V_{CC}$	mA
I_O	DC Output Source/Sink Current	± 50		mA
I_{CC}	DC Supply Current Per Supply Pin	± 100		mA
I_{GND}	DC Ground Current Per Ground Pin	± 100		mA
T_{STG}	Storage Temperature Range	-65 to +150		$^{\circ}C$
T_L	Lead Temperature, 1 mm from Case for 10 Seconds	$T_L = 260$		$^{\circ}C$
T_J	Junction Temperature Under Bias	$T_J = 135$		$^{\circ}C$
θ_{JA}	Thermal Resistance (Note 2)	SOIC = 85 TSSOP = 100		$^{\circ}C/W$
MSL	Moisture Sensitivity		Level 1	
$I_{LATCHUP}$	Latch-up Performance at $V_{CC} = 3.6 V$ and $125^{\circ}C$ (Note 3)		± 250	mA

Stresses exceeding those listed in the Maximum Ratings table may damage the device. If any of these limits are exceeded, device functionality should not be assumed, damage may occur and reliability may be affected.

- I_O absolute maximum rating must be observed.
- Measured with minimum pad spacing on an FR4 board, using 10 mm-by-1 inch, 2 ounce copper trace no air flow.
- Tested to EIA/JES078.

ORDERING INFORMATION

Device	Package	Shipping†
74LVC07ADR2G	SOIC-14 (Pb-Free)	2500 / Tape & Reel
74LVC07ADTR2G	TSSOP-14 (Pb-Free)	2500 / Tape & Reel

†For information on tape and reel specifications, including part orientation and tape sizes, please refer to our Tape and Reel Packaging Specifications Brochure, BRD8011/D.

74LVC07A

RECOMMENDED OPERATING CONDITIONS

Symbol	Parameter	Min	Typ	Max	Unit
V _{CC}	Supply Voltage	1.65 1.2		5.5 5.5	V
V _I	Input Voltage	0		5.5	V
V _O	Output Voltage	0		V _{CC} 5.5	V
I _{OL}	LOW Level Output Current			+32 +24 +12 +8	mA
T _A	Operating Free-Air Temperature	-40		+125	°C
Δt/ΔV	Input Transition Rise or Fall Rate	0 0		20 10	ns/V

Functional operation above the stresses listed in the Recommended Operating Ranges is not implied. Extended exposure to stresses beyond the Recommended Operating Ranges limits may affect device reliability.

DC ELECTRICAL CHARACTERISTICS

Symbol	Parameter	Conditions	-40 to +85°C			-40 to +125°C			Unit
			Min	Typ (Note 4)	Max	Min	Typ (Note 4)	Max	
V _{IH}	HIGH-level input voltage	V _{CC} = 1.2 V	1.08	-	-	1.08	-	-	V
		V _{CC} = 1.65 V to 1.95 V	0.65 x V _{CC}	-	-	0.65 x V _{CC}	-	-	
		V _{CC} = 2.3 V to 2.7 V	1.7	-	-	1.7	-	-	
		V _{CC} = 2.7 V to 3.6 V	2.0	-	-	2.0	-	-	
		V _{CC} = 4.5 V to 5.5 V	0.7 x V _{CC}	-	-	0.7 x V _{CC}	-	-	
V _{IL}	LOW-level input voltage	V _{CC} = 1.2 V	-	-	0.12	-	-	0.12	V
		V _{CC} = 1.65 V to 1.95 V	-	-	0.35 x V _{CC}	-	-	0.35 x V _{CC}	
		V _{CC} = 2.3 V to 2.7 V	-	-	0.7	-	-	0.7	
		V _{CC} = 2.7 V to 3.6 V	-	-	0.8	-	-	0.8	
		V _{CC} = 4.5 V to 5.5 V	-	-	0.3 x V _{CC}	-	-	0.3 x V _{CC}	
V _{OL}	LOW-level output voltage	V _I = V _{IH} or V _{IL}	-	-	-	-	-	-	V
		I _O = 100 μA; V _{CC} = 1.65 V to 3.6 V	-	-	0.2	-	-	0.3	
		I _O = 4 mA; V _{CC} = 1.65 V	-	-	0.45	-	-	0.65	
		I _O = 8 mA; V _{CC} = 2.3 V	-	-	0.6	-	-	0.8	
		I _O = 12 mA; V _{CC} = 2.7 V	-	-	0.4	-	-	0.6	
		I _O = 24 mA; V _{CC} = 3.0 V	-	-	0.55	-	-	0.8	
		I _O = 32 mA; V _{CC} = 4.5 V	-	-	0.55	-	-	0.8	
I _I	Input leakage current	V _I = 5.5 V or GND V _{CC} = 1.65 to 5.5 V	-	±0.1	±5	-	±0.1	±20	μA
I _{OZ}	OFF-state output current	V _I = V _{IH} ; V _O = 5.5 V or GND; V _{CC} = 1.65 to 5.5 V	-	±0.1	±5	-	±0.1	±20	μA
I _{OFF}	Power-off leakage current	V _I or V _O = 5.5 V; V _{CC} = 0 V	-	±0.1	±10	-	±0.1	±20	μA

4. All typical values are measured at T_A = 25°C and V_{CC} = 3.3 V, unless stated otherwise.

74LVC07A

DC ELECTRICAL CHARACTERISTICS

Symbol	Parameter	Conditions	-40 to +85°C			-40 to +125°C			Unit
			Min	Typ (Note 4)	Max	Min	Typ (Note 4)	Max	
I _{CC}	Supply current	V _I = V _{CC} or GND; I _O = 0 A; V _{CC} = 5.5 V	-	0.1	10	-	0.1	40	μA
ΔI _{CC}	Additional supply current	per input pin; V _I = V _{CC} - 0.6 V; I _O = 0 A; V _{CC} = 2.7 V to 5.5 V	-	5	500	-	5	5000	μA

4. All typical values are measured at T_A = 25°C and V_{CC} = 3.3 V, unless stated otherwise.

Product parametric performance is indicated in the Electrical Characteristics for the listed test conditions, unless otherwise noted. Product performance may not be indicated by the Electrical Characteristics if operated under different conditions.

AC ELECTRICAL CHARACTERISTICS (t_R = t_F = 2.5 ns)

Symbol	Parameter	Conditions	-40 to +85°C			-40 to +125°C			Unit
			Min	Typ (Note 5)	Max	Min	Typ (Note 5)	Max	
t _{pZL}	OFF-state to LOW propagation delay An to On	V _{CC} = 1.2 V	-	8.0	-	-	-	-	ns
		V _{CC} = 1.65 V to 1.95 V	0.5	1.7	5.5	0.5	-	6.5	
		V _{CC} = 2.3 V to 2.7 V	0.5	1.2	2.8	0.5	-	3.5	
		V _{CC} = 2.7 V	0.5	1.8	3.3	0.5	-	4.5	
		V _{CC} = 3.0 V to 3.6 V	0.5	1.2	3.6	0.5	-	4.5	
		V _{CC} = 4.5 V to 5.5 V	0.5	1.6	2.6	0.5	-	3.5	
t _{pLZ}	LOW to OFF-state propagation delay An to On	V _{CC} = 1.2 V	-	10.0	-	-	-	-	ns
		V _{CC} = 1.65 V to 1.95 V	0.5	3.0	5.5	0.5	-	6.5	
		V _{CC} = 2.3 V to 2.7 V	0.5	1.7	2.8	0.5	-	3.5	
		V _{CC} = 2.7 V	0.5	2.1	3.3	0.5	-	4.5	
		V _{CC} = 3.0 V to 3.6 V	0.5	2.5	3.6	0.5	-	4.5	
		V _{CC} = 4.5 V to 5.5 V	0.5	1.6	2.6	-	-	3.5	

5. Typical values are measured at T_A = 25°C and V_{CC} = 3.3 V, unless stated otherwise.

DYNAMIC SWITCHING CHARACTERISTICS

Symbol	Characteristic	Condition	Min	Typ	Max	Unit
V _{OLP}	Dynamic LOW Peak Voltage (Note 6)	V _{CC} = 3.3 V, C _L = 50 pF, V _{IH} = 3.3 V, V _{IL} = 0 V V _{CC} = 2.5 V, C _L = 30 pF, V _{IH} = 2.5 V, V _{IL} = 0 V		0.8 0.6		V
V _{OLV}	Dynamic LOW Valley Voltage (Note 6)	V _{CC} = 3.3 V, C _L = 50 pF, V _{IH} = 3.3 V, V _{IL} = 0 V V _{CC} = 2.5 V, C _L = 30 pF, V _{IH} = 2.5 V, V _{IL} = 0 V		-0.8 -0.6		V

6. Number of outputs defined as "n". Measured with "n-1" outputs switching from HIGH-to-LOW or LOW-to-HIGH. The remaining output is measured in the LOW state.

CAPACITIVE CHARACTERISTICS (T_A = +25°C)

Symbol	Parameter	Condition	Typical	Unit	
C _{IN}	Input Capacitance	V _{CC} = 3.3 V, V _I = 0 V or V _{CC}	5.0	pF	
C _{OUT}	Output Capacitance	V _{CC} = 3.3 V, V _I = 0 V or V _{CC}	6.0	pF	
C _{PD}	Power Dissipation Capacitance (Note 7)	Per input; V _I = GND or V _{CC}		pF	
		V _{CC} = 1.65 V to 1.95 V			6.5
		V _{CC} = 2.3 V to 2.7 V			6.9
		V _{CC} = 3.0 V to 3.6 V			7.2

7. C_{PD} is used to determine the dynamic power dissipation (P_D in μW)
 $P_D = C_{PD} \cdot V_{CC}^2 \cdot f_i \cdot N + L \cdot (C_L \cdot V_{CC}^2 \cdot f_o)$ where:
 f_i = input frequency in MHz; f_o = output frequency in MHz
 C_L = output load capacitance in pF V_{CC} = supply voltage in Volts
 N = number of outputs switching L (C_L * V_{CC}²)

74LVC07A

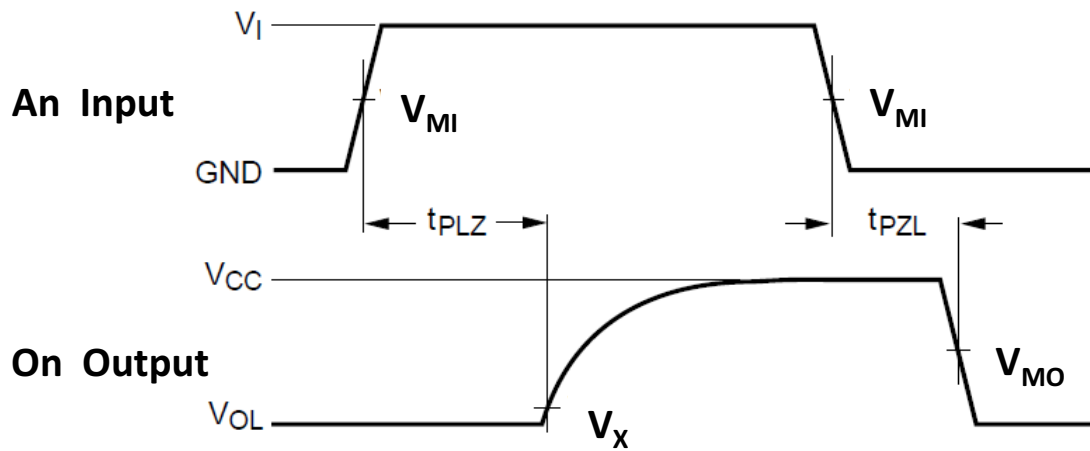

PROPAGATION DELAYS

$t_R = t_F = 2.5 \text{ ns}$, 10% to 90%; $f = 1 \text{ MHz}$; $t_W = 500 \text{ ns}$

Table 3. AC WAVEFORMS

Symbol	V_{CC}		
	$V_{CC} \geq 4.5 \text{ to } 5.5 \text{ V}$	$V_{CC} \geq 2.7 \text{ to } 3.6 \text{ V}$	$V_{CC} < 2.7 \text{ V}$
V_{MI}	$V_{CC} / 2$	1.5 V	$V_{CC} / 2$
V_{MO}	$V_{CC} / 2$	1.5 V	$V_{CC} / 2$
V_X	$V_{OL} + 0.3 \text{ V}$	$V_{OL} + 0.3 \text{ V}$	$V_{OL} + 0.15 \text{ V}$

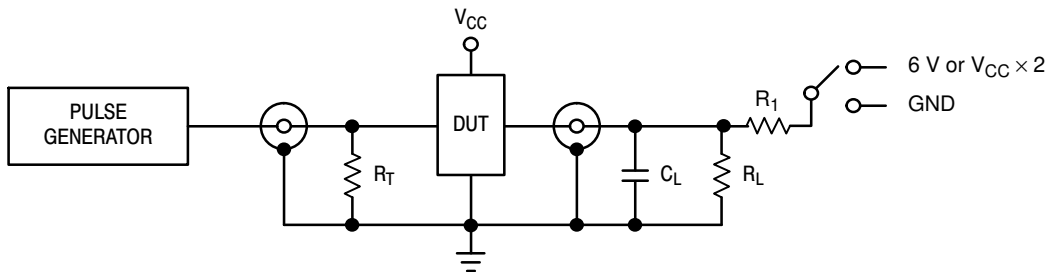

C_L includes jig and probe capacitance
 $R_T = Z_{OUT}$ of pulse generator (typically 50 Ω)
 $R_1 = R_L$

Table 4. TEST CIRCUIT

Supply Voltage	Input		Load		V_{EXT}		
$V_{CC} \text{ (V)}$	V_I	t_r, t_f	C_L	R_L	t_{PLH}, t_{PHL}	t_{PLZ}, t_{PZL}	t_{PHZ}, t_{PZH}
1.2	V_{CC}	$\leq 2 \text{ ns}$	30 pF	1 k Ω	Open	$2 \times V_{CC}$	GND
1.65 – 1.95	V_{CC}	$\leq 2 \text{ ns}$	30 pF	1 k Ω	Open	$2 \times V_{CC}$	GND
2.3 – 2.7	V_{CC}	$\leq 2 \text{ ns}$	30 pF	500 Ω	Open	$2 \times V_{CC}$	GND
2.7	2.7 V	$\leq 2.5 \text{ ns}$	50 pF	500 Ω	Open	$2 \times V_{CC}$	GND
3.0 – 3.6	2.7 V	$\leq 2.5 \text{ ns}$	50 pF	500 Ω	Open	$2 \times V_{CC}$	GND
4.5 to 5.5	V_{CC}	$\leq 2.5 \text{ ns}$	50 pF	500 Ω	Open	$2 \times V_{CC}$	GND

74LVC07A

PACKAGE DIMENSIONS

SOIC-14 NB
CASE 751A-03
ISSUE K

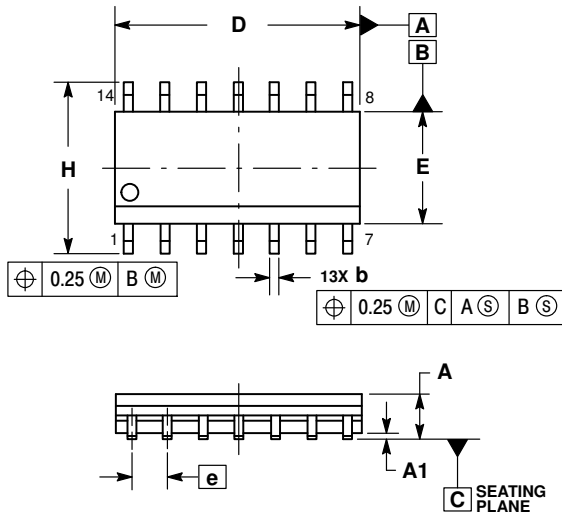

- NOTES:
1. DIMENSIONING AND TOLERANCING PER ASME Y14.5M, 1994.
 2. CONTROLLING DIMENSION: MILLIMETERS.
 3. DIMENSION b DOES NOT INCLUDE DAMBAR PROTRUSION. ALLOWABLE PROTRUSION SHALL BE 0.13 TOTAL IN EXCESS OF AT MAXIMUM MATERIAL CONDITION.
 4. DIMENSIONS D AND E DO NOT INCLUDE MOLD PROTRUSIONS.
 5. MAXIMUM MOLD PROTRUSION 0.15 PER SIDE.

DIM	MILLIMETERS		INCHES	
	MIN	MAX	MIN	MAX
A	1.35	1.75	0.054	0.068
A1	0.10	0.25	0.004	0.010
A3	0.19	0.25	0.008	0.010
b	0.35	0.49	0.014	0.019
D	8.55	8.75	0.337	0.344
E	3.80	4.00	0.150	0.157
e	1.27 BSC		0.050 BSC	
H	5.80	6.20	0.228	0.244
h	0.25	0.50	0.010	0.019
L	0.40	1.25	0.016	0.049
M	0°	7°	0°	7°

SOLDERING FOOTPRINT*

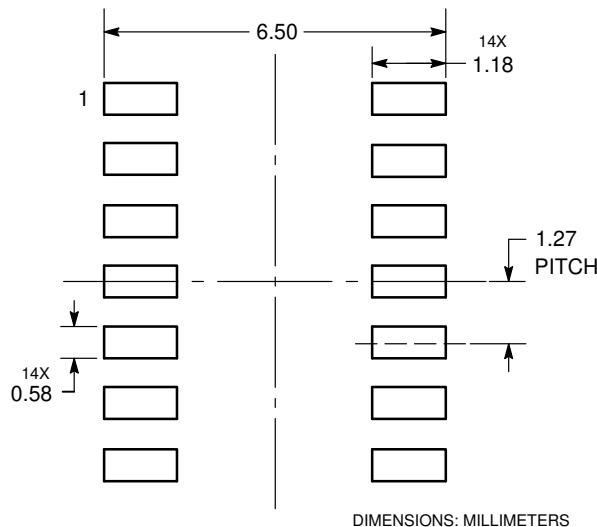

DIMENSIONS: MILLIMETERS

*For additional information on our Pb-Free strategy and soldering details, please download the ON Semiconductor Soldering and Mounting Techniques Reference Manual, SOLDERRM/D.

ON Semiconductor and the are registered trademarks of Semiconductor Components Industries, LLC (SCILLC) or its subsidiaries in the United States and/or other countries. SCILLC owns the rights to a number of patents, trademarks, copyrights, trade secrets, and other intellectual property. A listing of SCILLC's product/patent coverage may be accessed at www.onsemi.com/site/pdf/Patent-Marking.pdf. SCILLC reserves the right to make changes without further notice to any products herein. SCILLC makes no warranty, representation or guarantee regarding the suitability of its products for any particular purpose, nor does SCILLC assume any liability arising out of the application or use of any product or circuit, and specifically disclaims any and all liability, including without limitation special, consequential or incidental damages. "Typical" parameters which may be provided in SCILLC data sheets and/or specifications can and do vary in different applications and actual performance may vary over time. All operating parameters, including "Typicals" must be validated for each customer application by customer's technical experts. SCILLC does not convey any license under its patent rights nor the rights of others. SCILLC products are not designed, intended, or authorized for use as components in systems intended for surgical implant into the body, or other applications intended to support or sustain life, or for any other application in which the failure of the SCILLC product could create a situation where personal injury or death may occur. Should Buyer purchase or use SCILLC products for any such unintended or unauthorized application, Buyer shall indemnify and hold SCILLC and its officers, employees, subsidiaries, affiliates, and distributors harmless against all claims, costs, damages, and expenses, and reasonable attorney fees arising out of, directly or indirectly, any claim of personal injury or death associated with such unintended or unauthorized use, even if such claim alleges that SCILLC was negligent regarding the design or manufacture of the part. SCILLC is an Equal Opportunity/Affirmative Action Employer. This literature is subject to all applicable copyright laws and is not for resale in any manner.

PUBLICATION ORDERING INFORMATION

LITERATURE FULFILLMENT:
Literature Distribution Center for ON Semiconductor
P.O. Box 5163, Denver, Colorado 80217 USA
Phone: 303-675-2175 or 800-344-3860 Toll Free USA/Canada
Fax: 303-675-2176 or 800-344-3867 Toll Free USA/Canada
Email: orderlit@onsemi.com

N. American Technical Support: 800-282-9855 Toll Free
USA/Canada
Europe, Middle East and Africa Technical Support:
Phone: 421 33 790 2910
Japan Customer Focus Center
Phone: 81-3-5817-1050

ON Semiconductor Website: www.onsemi.com
Order Literature: <http://www.onsemi.com/orderlit>

For additional information, please contact your local Sales Representative