



Chipsmall Limited consists of a professional team with an average of over 10 year of expertise in the distribution of electronic components. Based in Hongkong, we have already established firm and mutual-benefit business relationships with customers from,Europe,America and south Asia,supplying obsolete and hard-to-find components to meet their specific needs.

With the principle of “Quality Parts,Customers Priority,Honest Operation,and Considerate Service”,our business mainly focus on the distribution of electronic components. Line cards we deal with include Microchip,ALPS,ROHM,Xilinx,Pulse,ON,Everlight and Freescale. Main products comprise IC,Modules,Potentiometer,IC Socket,Relay,Connector.Our parts cover such applications as commercial,industrial, and automotives areas.

We are looking forward to setting up business relationship with you and hope to provide you with the best service and solution. Let us make a better world for our industry!



Contact us

Tel: +86-755-8981 8866 Fax: +86-755-8427 6832

Email & Skype: info@chipsmall.com Web: www.chipsmall.com

Address: A1208, Overseas Decoration Building, #122 Zhenhua RD., Futian, Shenzhen, China



74LVC169

Presettable synchronous 4-bit up/down binary counter

Rev. 6 — 29 November 2012

Product data sheet

1. General description

The 74LVC169 is a synchronous presettable 4-bit binary counter which features an internal look-ahead carry circuitry for cascading in high-speed counting applications. Synchronous operation is provided by having all flip-flops clocked simultaneously so that the outputs (pins Q0 to Q3) change simultaneously with each other when so instructed by the count-enable (pins $\overline{\text{CEP}}$ and $\overline{\text{CET}}$) inputs and internal gating. This mode of operation eliminates the output counting spikes that are normally associated with asynchronous (ripple clock) counters. A buffered clock (pin CP) input triggers the four flip-flops on the LOW-to-HIGH transition of the clock.

The counter is fully programmable; that is, the outputs may be preset to any number between 0 and its maximum count. Presetting is synchronous with the clock and takes place regardless of the levels of the count enable inputs. A LOW level on the parallel enable (pin $\overline{\text{PE}}$) input disables the counter and causes the data at the Dn input to be loaded into the counter on the next LOW-to-HIGH transition of the clock. The direction of the counting is controlled by the up/down (pin U/D) input. When pin U/D is HIGH, the counter counts up, when LOW, it counts down.

The look-ahead carry circuitry is provided for cascading counters for n-bit synchronous applications without additional gating. Instrumental in accomplishing this function are two count-enable (pins $\overline{\text{CEP}}$ and $\overline{\text{CET}}$) inputs and a terminal count (pin $\overline{\text{TC}}$) output. Both count-enable (pins $\overline{\text{CEP}}$ and $\overline{\text{CET}}$) inputs must be LOW to count. Input pin $\overline{\text{CET}}$ is fed forward to enable the terminal count (pin $\overline{\text{TC}}$) output. Pin $\overline{\text{TC}}$ thus enabled will produce a LOW-level output pulse with a duration approximately equal to a HIGH level portion of pin Q0 output. The LOW level pin $\overline{\text{TC}}$ pulse is used to enable successive cascaded stages.

The 74LVC169 uses edge triggered J-K type flip-flops and has no constraints on changing the control of data input signals in either state of the clock. The only requirement is that the various inputs attain the desired state at least a set-up time before the next LOW-to-HIGH transition of the clock and remain valid for the recommended hold time thereafter.

The parallel load operation takes precedence over the other operations, as indicated in the mode select table. When pin $\overline{\text{PE}}$ is LOW, the data on the input pins D0 to D3 enters the flip-flops on the next LOW-to-HIGH transition of the clock.



In order for counting to occur, both pins \overline{CEP} and \overline{CET} must be LOW and pin \overline{PE} must be HIGH. The pin U/\overline{D} input determines the direction of the counting. The terminal count output pin \overline{TC} output is normally HIGH and goes LOW, provided that pin \overline{CET} is LOW, when a counter reaches 15 in the count up mode. The pin \overline{TC} output state is not a function of the count-enable parallel (pin \overline{CEP}) input level. Since pin \overline{TC} signal is derived by decoding the flip-flop states, there exists the possibility of decoding spikes on pin \overline{TC} . For this reason the use of pin \overline{TC} as a clock signal is not recommended; see the following logic equations:

$$\text{count enable} = \overline{CEP} \cdot \overline{CET} \cdot \overline{PE}$$

$$\text{count up: } \overline{TC} = Q_3 \cdot Q_2 \cdot Q_1 \cdot Q_0 \cdot \overline{CET} \cdot U/\overline{D}$$

$$\text{count down: } \overline{TC} = \overline{Q_3} \cdot \overline{Q_2} \cdot \overline{Q_1} \cdot \overline{Q_0} \cdot \overline{CET} \cdot \overline{U/D}$$

2. Features and benefits

- 5 V tolerant inputs for interfacing with 5 V logic
- Wide supply voltage range from 1.2 V to 3.6 V
- CMOS low power consumption
- Direct interface with TTL levels
- Up/down counting
- Two count enable inputs for n-bit cascading
- Built-in look-ahead carry capability
- Presettable for programmable operation
- Complies with JEDEC standard:
 - ◆ JESD8-7A (1.65 V to 1.95 V)
 - ◆ JESD8-5A (2.3 V to 2.7 V)
 - ◆ JESD8-C/JESD36 (2.7 V to 3.6 V)
- ESD protection:
 - ◆ HBM JESD22-A114F exceeds 2000 V
 - ◆ MM JESD22-A115-B exceeds 200 V
 - ◆ CDM JESD22-C101E exceeds 1000 V
- Multiple package options
- Specified from $-40\text{ }^{\circ}\text{C}$ to $+85\text{ }^{\circ}\text{C}$ and from $-40\text{ }^{\circ}\text{C}$ to $+125\text{ }^{\circ}\text{C}$

3. Ordering information

Table 1. Ordering information

Type number	Temperature range	Package		
		Name	Description	Version
74LVC169D	-40 °C to +125 °C	SO16	plastic small outline package; 16 leads; body width 3.9 mm	SOT109-1
74LVC169DB	-40 °C to +125 °C	SSOP16	plastic shrink small outline package; 16 leads; body width 5.3 mm	SOT338-1
74LVC169PW	-40 °C to +125 °C	TSSOP16	plastic thin shrink small outline package; 16 leads; body width 4.4 mm	SOT403-1
74LVC169BQ	-40 °C to +125 °C	DHVQFN16	plastic dual in-line compatible thermal enhanced very thin quad flat package; no leads; 16 terminals; body 2.5 × 3.5 × 0.85 mm	SOT763-1

4. Functional diagram

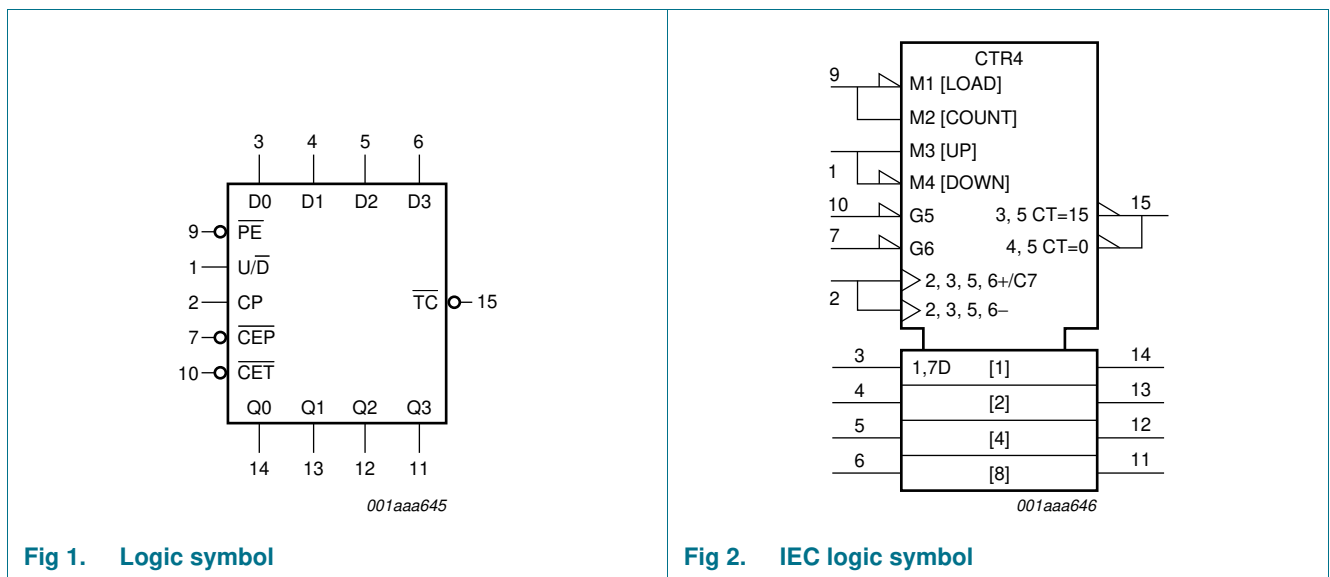

5. Pinning information

5.1 Pinning

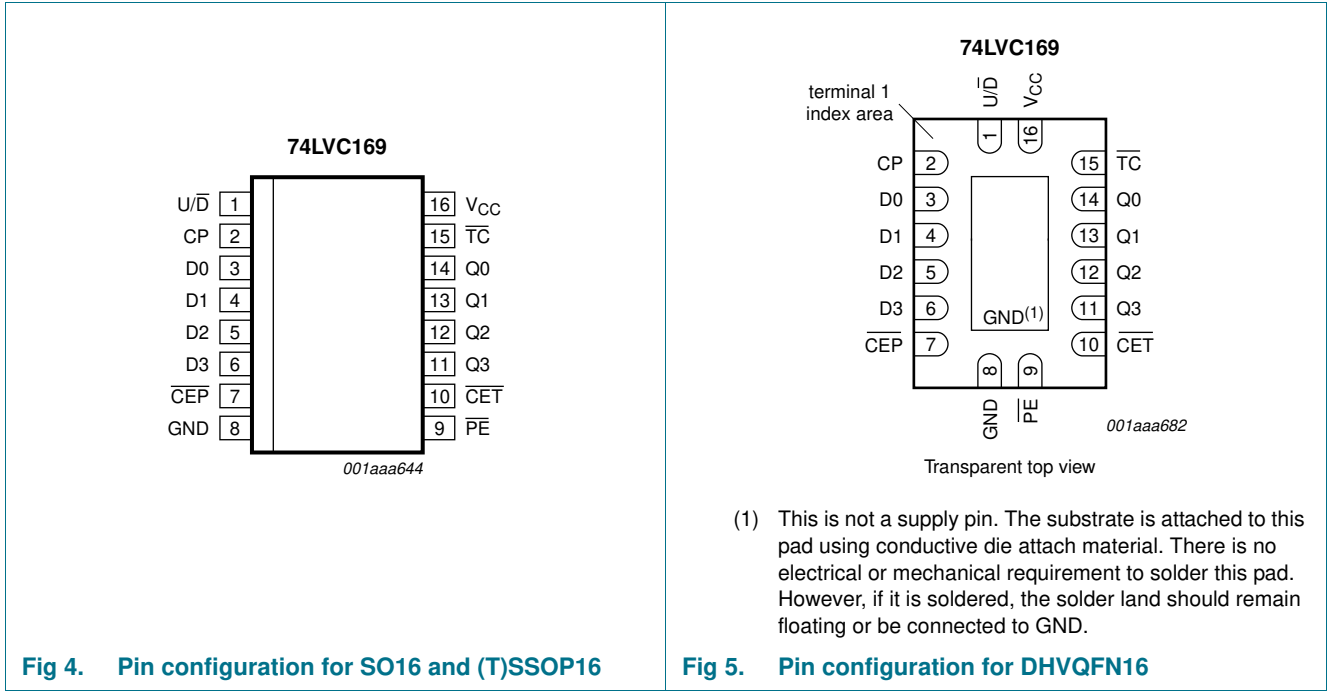

5.2 Pin description

Table 2. Pin description

Symbol	Pin	Description
U/ \bar{D}	1	up/down control input
CP	2	clock input (LOW-to-HIGH, edge-triggered)
D0 to D3	3, 4, 5, 6	data input
\overline{CEP}	7	count enable input (active LOW)
GND	8	ground (0 V)
\overline{PE}	9	parallel enable input (active LOW)
\overline{CET}	10	count enable carry input (active LOW)
Q0 to Q3	14, 13, 12, 11	flip-flop output
\overline{TC}	15	terminal count output (active LOW)
V _{CC}	16	supply voltage

6. Functional description

Table 3. Function table^[1]

Operating mode	Input						Output	
	CP	U/D	CEP	CET	PE	Dn	Qn	TC
Parallel load (Dn to Qn)	↑	X	X	X	l	l	L	*
	↑	X	X	X	l	h	H	*
Count up (increment)	↑	h	l	l	h	X	count up	*
Count down (decrement)	↑	l	l	l	h	X	count down	*
Hold (do nothing)	↑	X	h	X	h	X	qn	*
	↑	X	X	X	h	X	qn	H

- [1] H = HIGH voltage level steady state
 h = HIGH voltage level one set-up time prior to the LOW-to-HIGH clock transition
 L = LOW voltage level steady state
 l = LOW voltage level one set-up time prior to the LOW-to-HIGH clock transition
 qn = Lower case letters indicate state of referenced output prior to the LOW-to-HIGH clock transition
 X = don't care
 ↑ = LOW-to-HIGH clock transition
 * = The TC is LOW when CET is LOW and the counter is at terminal count
 Terminal count up is (HHHH) and terminal count down is (LLLL)

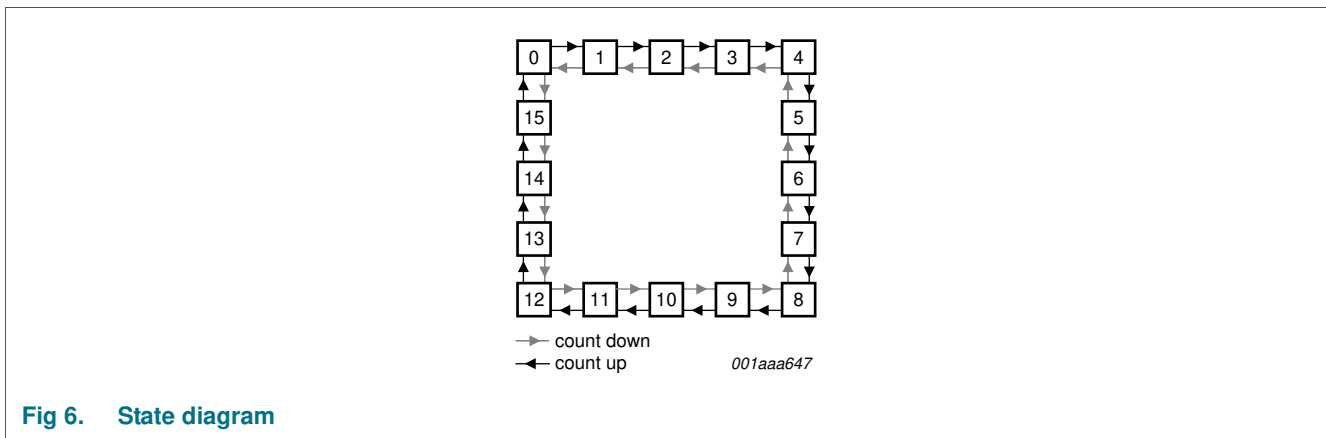
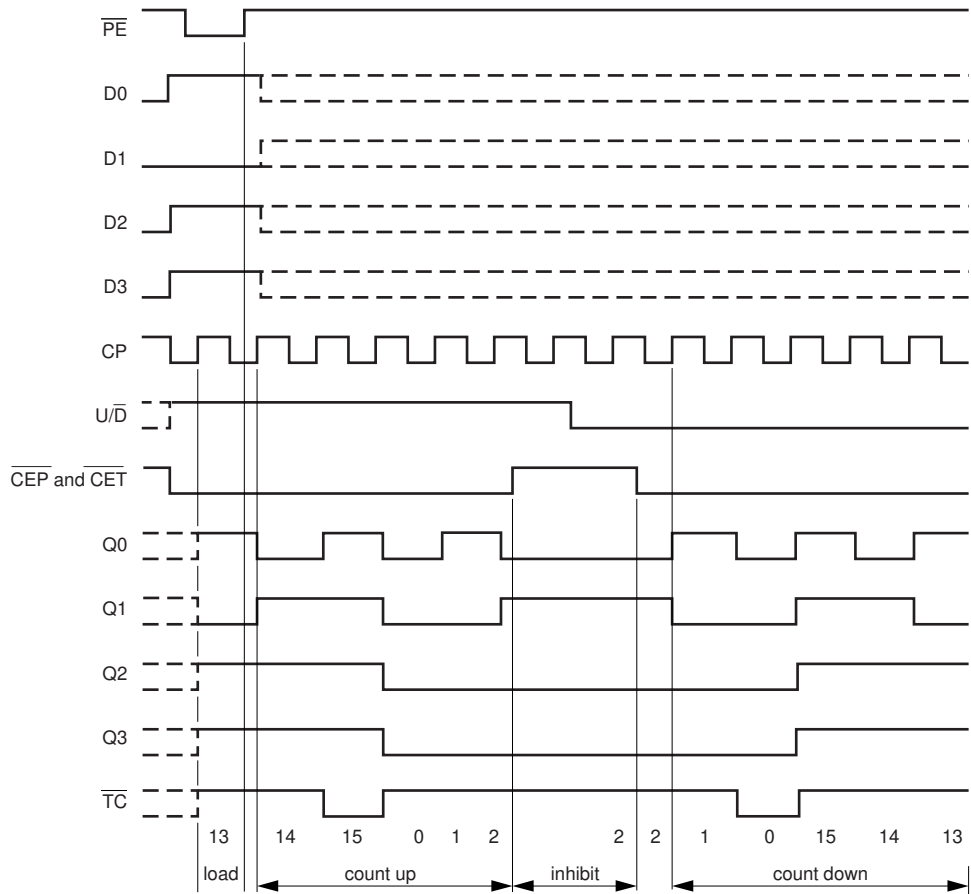

Fig 6. State diagram



001aaa648

The following sequence is illustrated:

- Load (preset) to thirteen.
- Count up to fourteen, fifteen (maximum), zero, one and two.
- Inhibit.
- Count down to one, zero (minimum), fifteen, fourteen and thirteen.

Fig 7. Typical timing sequence

7. Limiting values

Table 4. Limiting values

In accordance with the Absolute Maximum Rating System (IEC 60134). Voltages are referenced to GND (ground = 0 V).

Symbol	Parameter	Conditions	Min	Max	Unit
V_{CC}	supply voltage		-0.5	+6.5	V
I_{IK}	input clamping current	$V_I < 0$ V	-50	-	mA
V_I	input voltage		[1] -0.5	+5.5	V
I_{OK}	output clamping current	$V_O > V_{CC}$ or $V_O < 0$ V	-	± 50	mA
V_O	output voltage		[2] -0.5	$V_{CC} + 0.5$	V
I_O	output current		-	± 50	mA
I_{CC}	supply current		-	100	mA
I_{GND}	ground current		-100	-	mA
T_{stg}	storage temperature		-65	+150	°C
P_{tot}	total power dissipation	$T_{amb} = -40$ °C to +125 °C	[3] -	500	mW

[1] The minimum input voltage ratings may be exceeded if the input current ratings are observed.

[2] The output voltage ratings may be exceeded if the output current ratings are observed.

[3] For SO16 packages: above 70 °C the value of P_{tot} derates linearly with 8 mW/K.

For (T)SSOP16 packages: above 60 °C the value of P_{tot} derates linearly with 5.5 mW/K.

For DHVQFN16 packages: above 60 °C the value of P_{tot} derates linearly with 4.5 mW/K.

8. Recommended operating conditions

Table 5. Recommended operating conditions

Symbol	Parameter	Conditions	Min	Typ	Max	Unit
V_{CC}	supply voltage		1.65	-	3.6	V
		functional	1.2	-	-	V
V_I	input voltage		0	-	5.5	V
V_O	output voltage		0	-	V_{CC}	V
T_{amb}	ambient temperature	in free air	-40	-	+125	°C
$\Delta t/\Delta V$	input transition rise and fall rate	$V_{CC} = 1.65$ V to 2.7 V	0	-	20	ns/V
		$V_{CC} = 2.7$ V to 3.6 V	0	-	10	ns/V

9. Static characteristics

Table 6. Static characteristics

At recommended operating conditions. Voltages are referenced to GND (ground = 0 V).

Symbol	Parameter	Conditions	-40 °C to +85 °C			-40 °C to +125 °C		Unit
			Min	Typ ^[1]	Max	Min	Max	
V _{IH}	HIGH-level input voltage	V _{CC} = 1.2 V	1.08	-	-	1.08	-	V
		V _{CC} = 1.65 V to 1.95 V	0.65 × V _{CC}	-	-	0.65 × V _{CC}	-	V
		V _{CC} = 2.3 V to 2.7 V	1.7	-	-	1.7	-	V
		V _{CC} = 2.7 V to 3.6 V	2.0	-	-	2.0	-	V
V _{IL}	LOW-level input voltage	V _{CC} = 1.2 V	-	-	0.12	-	0.12	V
		V _{CC} = 1.65 V to 1.95 V	-	-	0.35 × V _{CC}	-	0.35 × V _{CC}	V
		V _{CC} = 2.3 V to 2.7 V	-	-	0.7	-	0.7	V
		V _{CC} = 2.7 V to 3.6 V	-	-	0.8	-	0.8	V
V _{OH}	HIGH-level output voltage	V _I = V _{IH} or V _{IL}						
		I _O = -100 μA; V _{CC} = 1.65 V to 3.6 V	V _{CC} - 0.2	-	-	V _{CC} - 0.3	-	V
		I _O = -4 mA; V _{CC} = 1.65 V	1.2	-	-	1.05	-	V
		I _O = -8 mA; V _{CC} = 2.3 V	1.8	-	-	1.65	-	V
		I _O = -12 mA; V _{CC} = 2.7 V	2.2	-	-	2.05	-	V
		I _O = -18 mA; V _{CC} = 3.0 V	2.4	-	-	2.25	-	V
		I _O = -24 mA; V _{CC} = 3.0 V	2.2	-	-	2.0	-	V
V _{OL}	LOW-level output voltage	V _I = V _{IH} or V _{IL}						
		I _O = 100 μA; V _{CC} = 1.65 V to 3.6 V	-	-	0.2	-	0.3	V
		I _O = 4 mA; V _{CC} = 1.65 V	-	-	0.45	-	0.65	V
		I _O = 8 mA; V _{CC} = 2.3 V	-	-	0.6	-	0.8	V
		I _O = 12 mA; V _{CC} = 2.7 V	-	-	0.4	-	0.6	V
		I _O = 24 mA; V _{CC} = 3.0 V	-	-	0.55	-	0.8	V
I _I	input leakage current	V _{CC} = 3.6 V; V _I = 5.5 V or GND	-	±0.1	±5	-	±20	μA
I _{CC}	supply current	V _{CC} = 3.6 V; V _I = V _{CC} or GND; I _O = 0 A	-	0.1	10	-	40	μA
ΔI _{CC}	additional supply current	per input pin; V _{CC} = 2.7 V to 3.6 V; V _I = V _{CC} - 0.6 V; I _O = 0 A	-	5	500	-	5000	μA
C _I	input capacitance	V _{CC} = 0 V to 3.6 V; V _I = GND to V _{CC}	-	5.0	-	-	-	pF

[1] All typical values are measured at V_{CC} = 3.3 V (unless stated otherwise) and T_{amb} = 25 °C.

10. Dynamic characteristics

Table 7. Dynamic characteristics

Voltages are referenced to GND (ground = 0 V). For test circuit see [Figure 13](#).

Symbol	Parameter	Conditions	-40 °C to +85 °C			-40 °C to +125 °C		Unit
			Min	Typ ^[1]	Max	Min	Max	
t _{pd}	propagation delay	CP to Qn; see Figure 8 ^[2]						
		V _{CC} = 1.2 V	-	17	-	-	-	ns
		V _{CC} = 1.65 V to 1.95 V	1.5	7.1	13.1	1.5	15.1	ns
		V _{CC} = 2.3 V to 2.7 V	2.4	4.1	7.4	2.4	8.6	ns
		V _{CC} = 2.7 V	1.5	3.9	7.2	1.5	9.0	ns
		V _{CC} = 3.0 V to 3.6 V	1.5	3.7	6.6	1.5	10.0	ns
		CP to $\overline{\text{TC}}$; see Figure 8 ^[2]						
		V _{CC} = 1.2 V	-	21	-	-	-	ns
		V _{CC} = 1.65 V to 1.95 V	2.0	8.5	14.9	2.0	17.2	ns
		V _{CC} = 2.3 V to 2.7 V	3.0	4.9	8.4	3.0	9.7	ns
		V _{CC} = 2.7 V	1.5	4.7	8.8	1.5	11.0	ns
		V _{CC} = 3.0 V to 3.6 V	1.5	4.4	7.5	1.5	9.5	ns
		CET to $\overline{\text{TC}}$; see Figure 9 ^[2]						
		V _{CC} = 1.2 V	-	19	-	-	-	ns
		V _{CC} = 1.65 V to 1.95 V	1.5	6.6	12.3	1.5	14.2	ns
		V _{CC} = 2.3 V to 2.7 V	2.2	3.8	7.0	2.2	8.1	ns
		V _{CC} = 2.7 V	1.5	4.0	7.2	1.5	9.0	ns
		V _{CC} = 3.0 V to 3.6 V	1.5	3.4	6.2	1.5	8.0	ns
		U/ $\overline{\text{D}}$ to $\overline{\text{TC}}$; see Figure 10 ^[2]						
		V _{CC} = 1.2 V	-	21	-	-	-	ns
V _{CC} = 1.65 V to 1.95 V	1.0	7.3	13.7	1.0	15.8	ns		
V _{CC} = 2.3 V to 2.7 V	1.7	4.2	7.7	1.7	8.9	ns		
V _{CC} = 2.7 V	1.5	4.4	8.2	1.5	10.5	ns		
V _{CC} = 3.0 V to 3.6 V	1.5	3.8	6.9	1.5	9.0	ns		
t _w	pulse width	CP HIGH or LOW; see Figure 8						
		V _{CC} = 1.65 V to 1.95 V	6.0	-	-	6.0	-	ns
		V _{CC} = 2.3 V to 2.7 V	5.0	-	-	5.0	-	ns
		V _{CC} = 2.7 V	5.0	-	-	5.0	-	ns
		V _{CC} = 3.0 V to 3.6 V	4.0	1.2	-	4.0	-	ns

Table 7. Dynamic characteristics ...continuedVoltages are referenced to GND (ground = 0 V). For test circuit see [Figure 13](#).

Symbol	Parameter	Conditions	-40 °C to +85 °C			-40 °C to +125 °C		Unit	
			Min	Typ ^[1]	Max	Min	Max		
t_{su}	set-up time	Dn to CP; see Figure 11							
		$V_{CC} = 1.65\text{ V to }1.95\text{ V}$	5.5	-	-	5.5	-	ns	
		$V_{CC} = 2.3\text{ V to }2.7\text{ V}$	4.5	-	-	4.5	-	ns	
		$V_{CC} = 2.7\text{ V}$	3.0	-	-	3.0	-	ns	
		$V_{CC} = 3.0\text{ V to }3.6\text{ V}$	2.5	1.0	-	2.5	-	ns	
		\overline{PE} to CP; see Figure 11							
		$V_{CC} = 1.65\text{ V to }1.95\text{ V}$	4.5	-	-	4.5	-	ns	
		$V_{CC} = 2.3\text{ V to }2.7\text{ V}$	4.0	-	-	4.0	-	ns	
		$V_{CC} = 2.7\text{ V}$	3.5	-	-	3.5	-	ns	
		$V_{CC} = 3.0\text{ V to }3.6\text{ V}$	3.0	1.2	-	3.0	-	ns	
		U/\overline{D} to CP; see Figure 12							
		$V_{CC} = 1.65\text{ V to }1.95\text{ V}$	9.0	-	-	9.0	-	ns	
		$V_{CC} = 2.3\text{ V to }2.7\text{ V}$	7.0	-	-	7.0	-	ns	
		$V_{CC} = 2.7\text{ V}$	6.5	-	-	6.5	-	ns	
		$V_{CC} = 3.0\text{ V to }3.6\text{ V}$	5.5	2.8	-	5.5	-	ns	
		\overline{CEP} , \overline{CET} to CP; see Figure 12							
$V_{CC} = 1.65\text{ V to }1.95\text{ V}$	9.0	-	-	9.0	-	ns			
$V_{CC} = 2.3\text{ V to }2.7\text{ V}$	6.0	-	-	6.0	-	ns			
$V_{CC} = 2.7\text{ V}$	5.5	-	-	5.5	-	ns			
$V_{CC} = 3.0\text{ V to }3.6\text{ V}$	4.5	2.1	-	4.5	-	ns			
t_h	hold time	Dn, \overline{PE} , \overline{CEP} , \overline{CET} , U/\overline{D} to CP; see Figure 11 and 12							
		$V_{CC} = 1.65\text{ V to }1.95\text{ V}$	1.0	-	-	1.0	-	ns	
		$V_{CC} = 2.3\text{ V to }2.7\text{ V}$	1.0	-	-	1.0	-	ns	
		$V_{CC} = 2.7\text{ V}$	0.0	-	-	0.0	-	ns	
f_{max}	maximum frequency	$V_{CC} = 3.0\text{ V to }3.6\text{ V}$	0.5	0.0	-	0.5	-	ns	
		see Figure 8							
		$V_{CC} = 1.65\text{ V to }1.95\text{ V}$	100	-	-	80	-	MHz	
		$V_{CC} = 2.3\text{ V to }2.7\text{ V}$	125	-	-	100	-	MHz	
$t_{sk(o)}$	output skew time	$V_{CC} = 2.7\text{ V}$	150	-	-	120	-	MHz	
		$V_{CC} = 3.0\text{ V to }3.6\text{ V}$	150	200	-	120	-	MHz	
		$V_{CC} = 3.0\text{ V to }3.6\text{ V}$	^[3]	-	-	1.0	-	1.5	ns

Table 7. Dynamic characteristics ...continued
 Voltages are referenced to GND (ground = 0 V). For test circuit see [Figure 13](#).

Symbol	Parameter	Conditions	-40 °C to +85 °C			-40 °C to +125 °C		Unit
			Min	Typ ^[1]	Max	Min	Max	
C _{PD}	power dissipation capacitance	per input pin; V _I = GND to V _{CC} ^[4]						
		V _{CC} = 1.65 V to 1.95 V	-	12.7	-	-	-	pF
		V _{CC} = 2.3 V to 2.7 V	-	16.4	-	-	-	pF
		V _{CC} = 3.0 V to 3.6 V	-	19.7	-	-	-	pF

- [1] Typical values are measured at T_{amb} = 25 °C and V_{CC} = 1.2 V, 1.8 V, 2.5 V, 2.7 V and 3.3 V respectively.
- [2] t_{pd} is the same as t_{PLH} and t_{PHL}.
- [3] Skew between any two outputs of the same package switching in the same direction. This parameter is guaranteed by design.
- [4] C_{PD} is used to determine the dynamic power dissipation (P_D in μW).
 $P_D = C_{PD} \times V_{CC}^2 \times f_i \times N + \sum(C_L \times V_{CC}^2 \times f_o)$ where:
 f_i = input frequency in MHz; f_o = output frequency in MHz
 C_L = output load capacitance in pF
 V_{CC} = supply voltage in Volt
 N = number of inputs switching
 $\sum(C_L \times V_{CC}^2 \times f_o)$ = sum of outputs

11. Waveforms

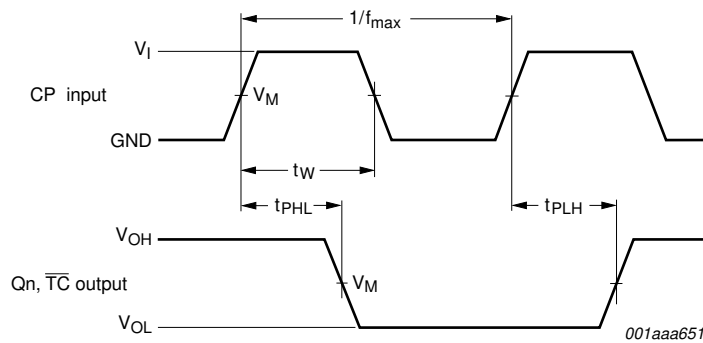

Measurement points are given in [Table 8](#).
 Logic levels: V_{OL} and V_{OH} are the typical output voltage levels that occur with the output load.

Fig 8. Clock (CP) to outputs (Qn, TC) propagation delays, the clock pulse width, and the maximum frequency

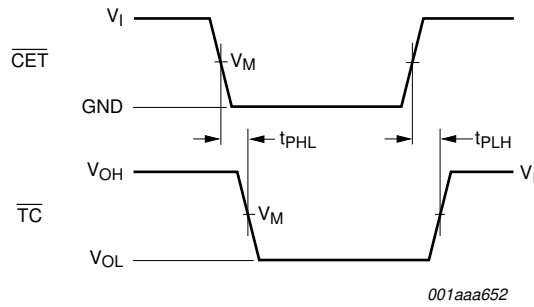

Measurement points are given in [Table 8](#).

Logic levels: V_{OL} and V_{OH} are the typical output voltage levels that occur with the output load.

Fig 9. Input (\overline{CET}) to output (\overline{TC}) propagation delays

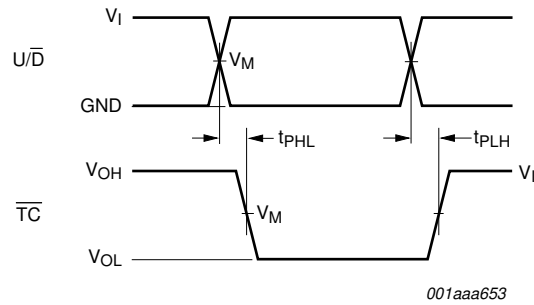

Measurement points are given in [Table 8](#).

Logic levels: V_{OL} and V_{OH} are the typical output voltage levels that occur with the output load.

Fig 10. The up/down control input ($\overline{U/D}$) to output (\overline{TC}) propagation delays

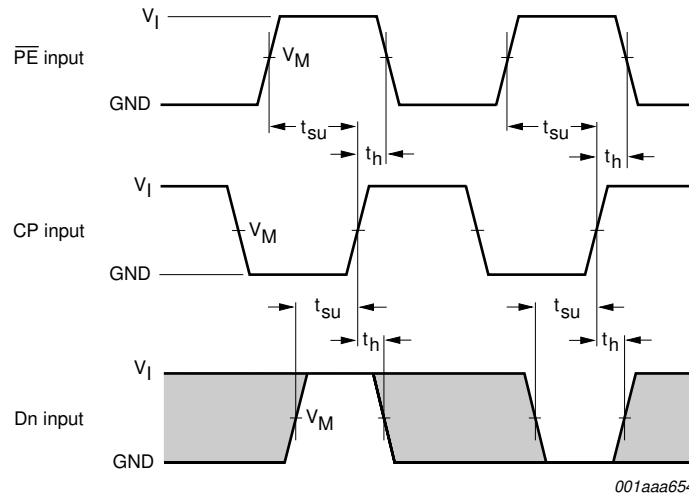

001aaa654

The shaded areas indicate when the input is permitted to change for predictable output performance.

Measurement points are given in [Table 8](#).

Logic levels: V_{OL} and V_{OH} are the typical output voltage levels that occur with the output load.

Fig 11. Set-up and hold times for the input (Dn) and parallel enable input (\overline{PE})

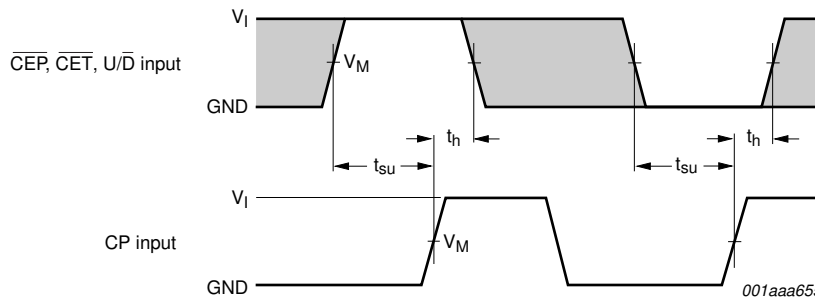

001aaa655

The shaded areas indicate when the input is permitted to change for predictable output performance.

Measurement points are given in [Table 8](#).

Logic levels: V_{OL} and V_{OH} are the typical output voltage levels that occur with the output load.

Fig 12. Set-up and hold times for count enable inputs (\overline{CEP} and \overline{CET}) and control input ($\overline{U/D}$)

Table 8. Measurement points

Supply voltage	Input		Output
V _{CC}	V _I	V _M	V _M
1.2 V	V _{CC}	0.5 × V _{CC}	0.5 × V _{CC}
1.65 V to 1.95 V	V _{CC}	0.5 × V _{CC}	0.5 × V _{CC}
2.3 V to 2.7 V	V _{CC}	0.5 × V _{CC}	0.5 × V _{CC}
2.7 V	2.7 V	1.5 V	1.5 V
3.0 V to 3.6 V	2.7 V	1.5 V	1.5 V

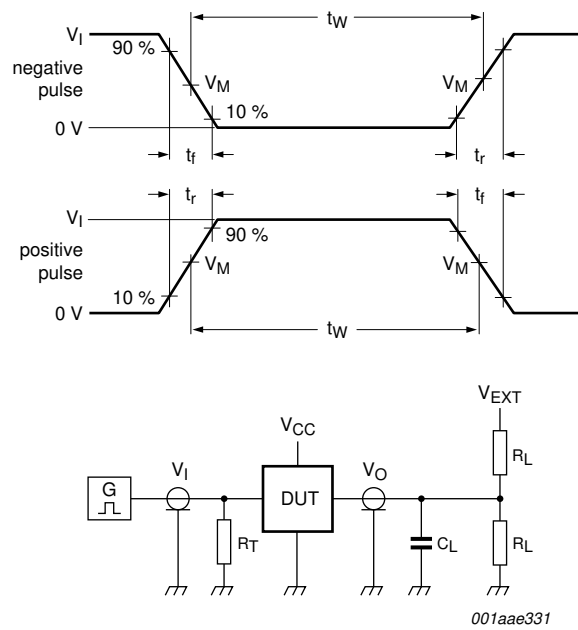

Test data is given in [Table 9](#).

Definitions for test circuit:

R_L = Load resistance.

C_L = Load capacitance including jig and probe capacitance.

R_T = Termination resistance should be equal to output impedance Z_o of the pulse generator.

V_{EXT} = External voltage for measuring switching times.

Fig 13. Test circuit for measuring switching times

Table 9. Test data

Supply voltage	Input		Load		S1 position
V_{CC}	V_I	t_r, t_f	C_L	R_L	t_{PLH}, t_{PHL}
1.2 V	V_{CC}	≤ 2 ns	30 pF	1 k Ω ^[1]	open
1.65 V to 1.95 V	V_{CC}	≤ 2 ns	30 pF	1 k Ω ^[1]	open
2.3 V to 2.7 V	V_{CC}	≤ 2 ns	30 pF	500 Ω	open
2.7 V	2.7 V	≤ 2.5 ns	50 pF	500 Ω	open
3.0 V to 3.6 V	2.7 V	≤ 2.5 ns	50 pF	500 Ω	open

[1] The circuit performs better when $R_L = 1000$ k Ω .

12. Application information

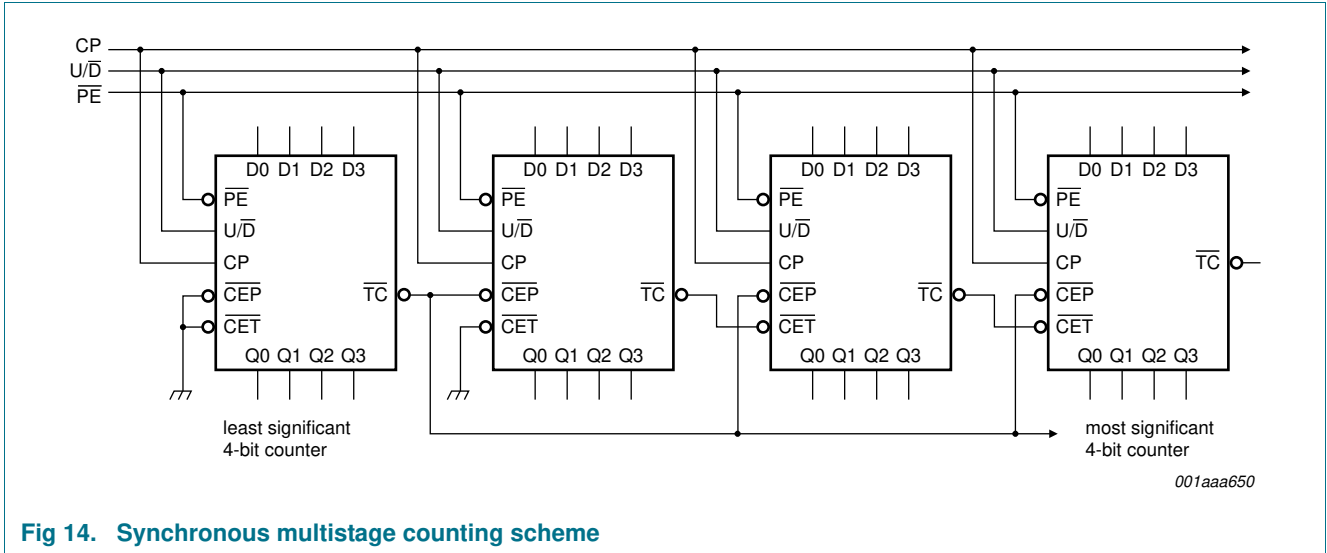

Fig 14. Synchronous multistage counting scheme

13. Package outline

SO16: plastic small outline package; 16 leads; body width 3.9 mm

SOT109-1

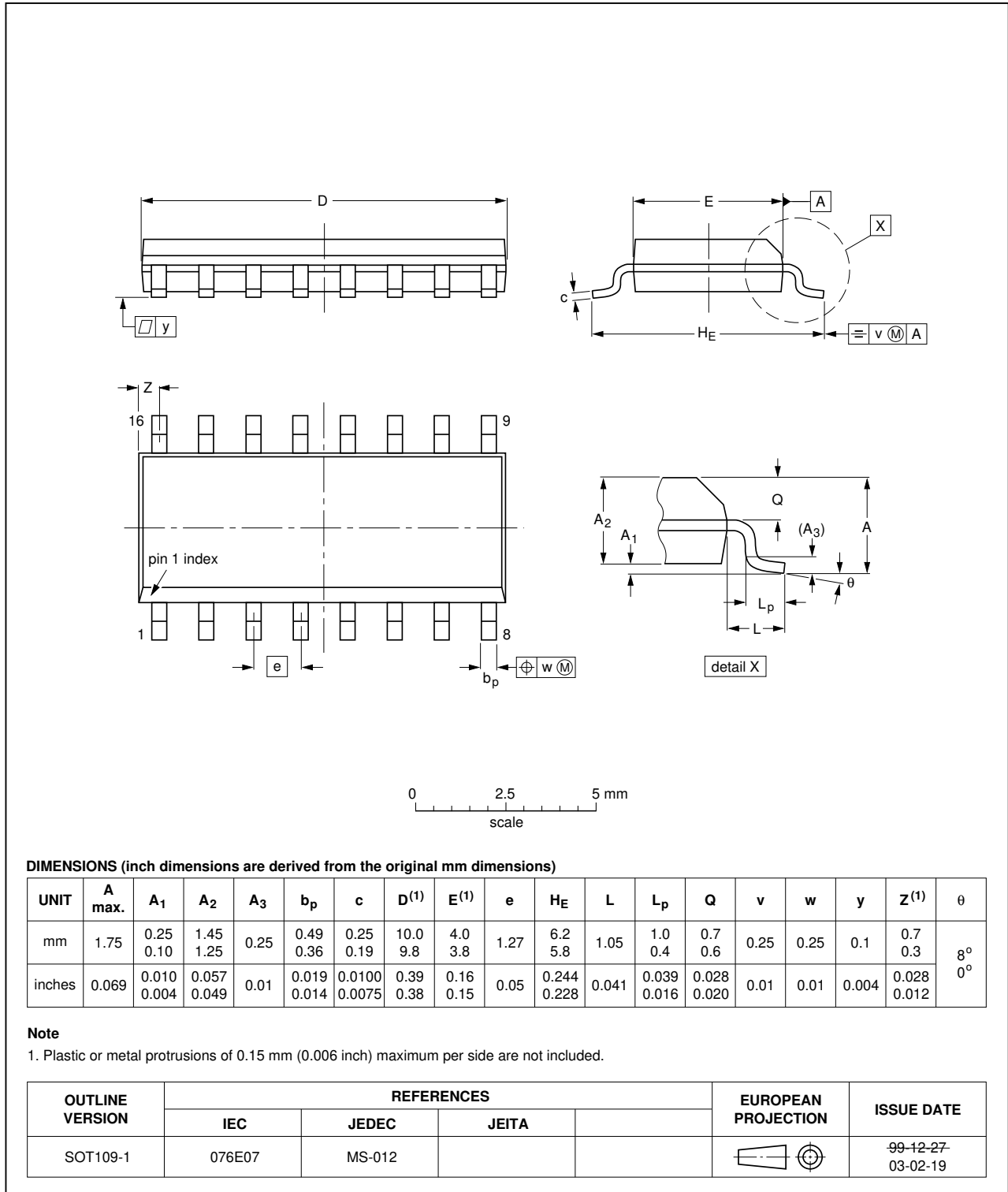

Fig 15. Package outline SOT109-1 (SO16)

SSOP16: plastic shrink small outline package; 16 leads; body width 5.3 mm

SOT338-1

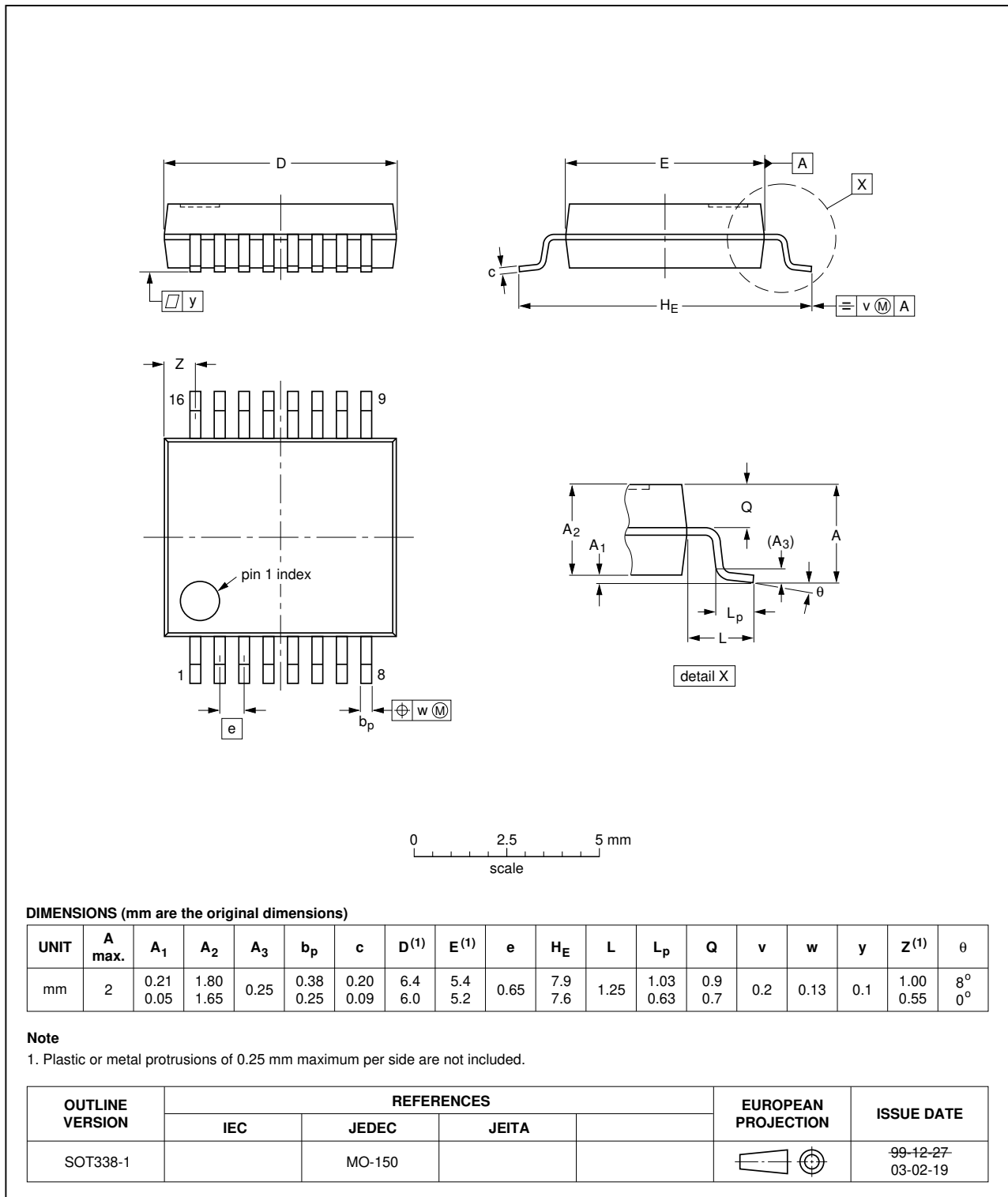

Fig 16. Package outline SOT338-1 (SSOP16)

TSSOP16: plastic thin shrink small outline package; 16 leads; body width 4.4 mm

SOT403-1

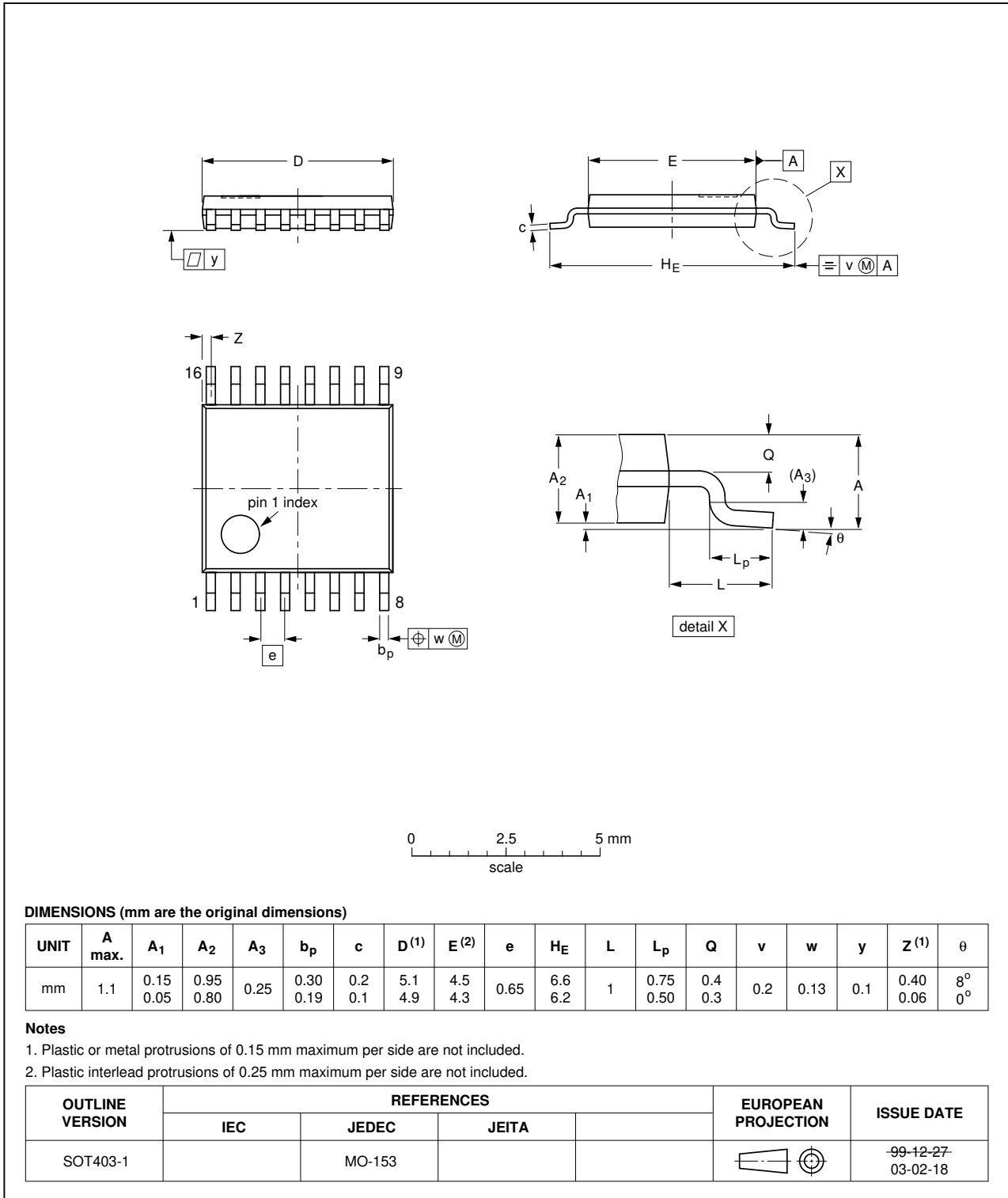

Fig 17. Package outline SOT403-1 (TSSOP16)

DHVQFN16: plastic dual in-line compatible thermal enhanced very thin quad flat package; no leads; 16 terminals; body 2.5 x 3.5 x 0.85 mm

SOT763-1

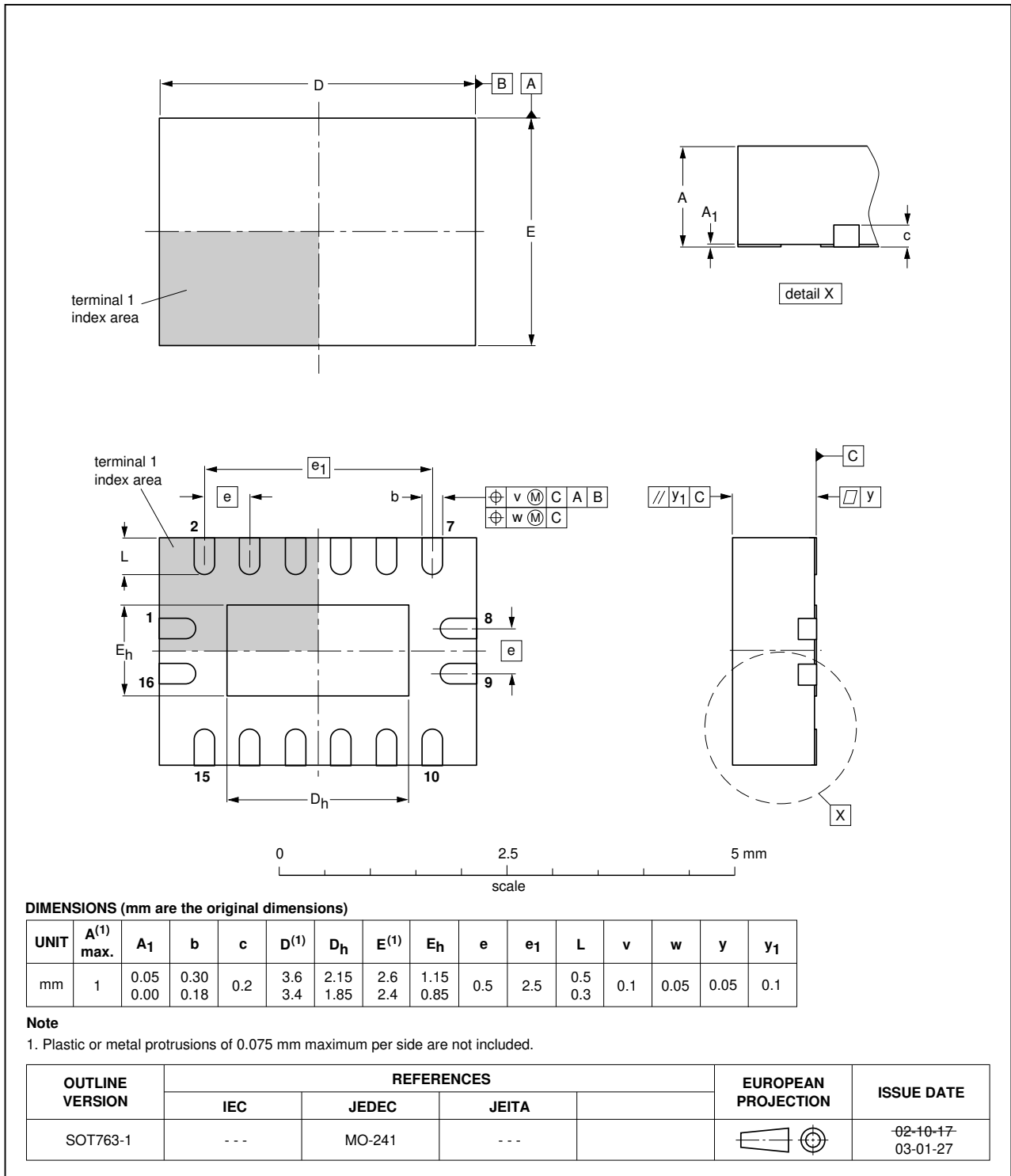

Fig 18. Package outline SOT763-1 (DHVQFN16)

14. Abbreviations

Table 10. Abbreviations

Acronym	Description
CDM	Charged Device Model
DUT	Device Under Test
ESD	ElectroStatic Discharge
HBM	Human Body Model
MM	Machine Model
TTL	Transistor-Transistor Logic

15. Revision history

Table 11. Revision history

Document ID	Release date	Data sheet status	Change notice	Supersedes
74LVC169 v.6	20121129	Product data sheet	-	74LVC169 v.5
Modifications:	<ul style="list-style-type: none"> Table 4, Table 5, Table 6, Table 7, Table 8 and Table 9: values added for lower voltage ranges. 			
74LVC169 v.5	20090608	Product data sheet	-	74LVC169 v.4
74LVC169 v.4	20041014	Product specification	-	74LVC169 v.3
74LVC169 v.3	20040512	Product specification	-	74LVC169 v.2
74LVC169 v.2	19980520	Product specification	-	74LVC169 v.1
74LVC169 v.1	19960823	Product specification	-	-

16. Legal information

16.1 Data sheet status

Document status ^{[1][2]}	Product status ^[3]	Definition
Objective [short] data sheet	Development	This document contains data from the objective specification for product development.
Preliminary [short] data sheet	Qualification	This document contains data from the preliminary specification.
Product [short] data sheet	Production	This document contains the product specification.

[1] Please consult the most recently issued document before initiating or completing a design.

[2] The term 'short data sheet' is explained in section "Definitions".

[3] The product status of device(s) described in this document may have changed since this document was published and may differ in case of multiple devices. The latest product status information is available on the Internet at URL <http://www.nxp.com>.

16.2 Definitions

Draft — The document is a draft version only. The content is still under internal review and subject to formal approval, which may result in modifications or additions. NXP Semiconductors does not give any representations or warranties as to the accuracy or completeness of information included herein and shall have no liability for the consequences of use of such information.

Short data sheet — A short data sheet is an extract from a full data sheet with the same product type number(s) and title. A short data sheet is intended for quick reference only and should not be relied upon to contain detailed and full information. For detailed and full information see the relevant full data sheet, which is available on request via the local NXP Semiconductors sales office. In case of any inconsistency or conflict with the short data sheet, the full data sheet shall prevail.

Product specification — The information and data provided in a Product data sheet shall define the specification of the product as agreed between NXP Semiconductors and its customer, unless NXP Semiconductors and customer have explicitly agreed otherwise in writing. In no event however, shall an agreement be valid in which the NXP Semiconductors product is deemed to offer functions and qualities beyond those described in the Product data sheet.

16.3 Disclaimers

Limited warranty and liability — Information in this document is believed to be accurate and reliable. However, NXP Semiconductors does not give any representations or warranties, expressed or implied, as to the accuracy or completeness of such information and shall have no liability for the consequences of use of such information. NXP Semiconductors takes no responsibility for the content in this document if provided by an information source outside of NXP Semiconductors.

In no event shall NXP Semiconductors be liable for any indirect, incidental, punitive, special or consequential damages (including - without limitation - lost profits, lost savings, business interruption, costs related to the removal or replacement of any products or rework charges) whether or not such damages are based on tort (including negligence), warranty, breach of contract or any other legal theory.

Notwithstanding any damages that customer might incur for any reason whatsoever, NXP Semiconductors' aggregate and cumulative liability towards customer for the products described herein shall be limited in accordance with the *Terms and conditions of commercial sale* of NXP Semiconductors.

Right to make changes — NXP Semiconductors reserves the right to make changes to information published in this document, including without limitation specifications and product descriptions, at any time and without notice. This document supersedes and replaces all information supplied prior to the publication hereof.

Suitability for use — NXP Semiconductors products are not designed, authorized or warranted to be suitable for use in life support, life-critical or safety-critical systems or equipment, nor in applications where failure or malfunction of an NXP Semiconductors product can reasonably be expected to result in personal injury, death or severe property or environmental damage. NXP Semiconductors and its suppliers accept no liability for inclusion and/or use of NXP Semiconductors products in such equipment or applications and therefore such inclusion and/or use is at the customer's own risk.

Applications — Applications that are described herein for any of these products are for illustrative purposes only. NXP Semiconductors makes no representation or warranty that such applications will be suitable for the specified use without further testing or modification.

Customers are responsible for the design and operation of their applications and products using NXP Semiconductors products, and NXP Semiconductors accepts no liability for any assistance with applications or customer product design. It is customer's sole responsibility to determine whether the NXP Semiconductors product is suitable and fit for the customer's applications and products planned, as well as for the planned application and use of customer's third party customer(s). Customers should provide appropriate design and operating safeguards to minimize the risks associated with their applications and products.

NXP Semiconductors does not accept any liability related to any default, damage, costs or problem which is based on any weakness or default in the customer's applications or products, or the application or use by customer's third party customer(s). Customer is responsible for doing all necessary testing for the customer's applications and products using NXP Semiconductors products in order to avoid a default of the applications and the products or of the application or use by customer's third party customer(s). NXP does not accept any liability in this respect.

Limiting values — Stress above one or more limiting values (as defined in the Absolute Maximum Ratings System of IEC 60134) will cause permanent damage to the device. Limiting values are stress ratings only and (proper) operation of the device at these or any other conditions above those given in the Recommended operating conditions section (if present) or the Characteristics sections of this document is not warranted. Constant or repeated exposure to limiting values will permanently and irreversibly affect the quality and reliability of the device.

Terms and conditions of commercial sale — NXP Semiconductors products are sold subject to the general terms and conditions of commercial sale, as published at <http://www.nxp.com/profile/terms>, unless otherwise agreed in a valid written individual agreement. In case an individual agreement is concluded only the terms and conditions of the respective agreement shall apply. NXP Semiconductors hereby expressly objects to applying the customer's general terms and conditions with regard to the purchase of NXP Semiconductors products by customer.

No offer to sell or license — Nothing in this document may be interpreted or construed as an offer to sell products that is open for acceptance or the grant, conveyance or implication of any license under any copyrights, patents or other industrial or intellectual property rights.

Export control — This document as well as the item(s) described herein may be subject to export control regulations. Export might require a prior authorization from competent authorities.

Non-automotive qualified products — Unless this data sheet expressly states that this specific NXP Semiconductors product is automotive qualified, the product is not suitable for automotive use. It is neither qualified nor tested in accordance with automotive testing or application requirements. NXP Semiconductors accepts no liability for inclusion and/or use of non-automotive qualified products in automotive equipment or applications.

In the event that customer uses the product for design-in and use in automotive applications to automotive specifications and standards, customer (a) shall use the product without NXP Semiconductors' warranty of the product for such automotive applications, use and specifications, and (b) whenever customer uses the product for automotive applications beyond

NXP Semiconductors' specifications such use shall be solely at customer's own risk, and (c) customer fully indemnifies NXP Semiconductors for any liability, damages or failed product claims resulting from customer design and use of the product for automotive applications beyond NXP Semiconductors' standard warranty and NXP Semiconductors' product specifications.

Translations — A non-English (translated) version of a document is for reference only. The English version shall prevail in case of any discrepancy between the translated and English versions.

16.4 Trademarks

Notice: All referenced brands, product names, service names and trademarks are the property of their respective owners.

17. Contact information

For more information, please visit: <http://www.nxp.com>

For sales office addresses, please send an email to: salesaddresses@nxp.com

18. Contents

1	General description	1
2	Features and benefits	2
3	Ordering information	3
4	Functional diagram	3
5	Pinning information	5
5.1	Pinning	5
5.2	Pin description	5
6	Functional description	6
7	Limiting values	8
8	Recommended operating conditions	8
9	Static characteristics	9
10	Dynamic characteristics	10
11	Waveforms	12
12	Application information	16
13	Package outline	17
14	Abbreviations	21
15	Revision history	21
16	Legal information	22
16.1	Data sheet status	22
16.2	Definitions	22
16.3	Disclaimers	22
16.4	Trademarks	23
17	Contact information	23
18	Contents	24

Please be aware that important notices concerning this document and the product(s) described herein, have been included in section 'Legal information'.

© NXP B.V. 2012.

All rights reserved.

For more information, please visit: <http://www.nxp.com>

For sales office addresses, please send an email to: salesaddresses@nxp.com

Date of release: 29 November 2012

Document identifier: 74LVC169