



Chipsmall Limited consists of a professional team with an average of over 10 year of expertise in the distribution of electronic components. Based in Hongkong, we have already established firm and mutual-benefit business relationships with customers from,Europe,America and south Asia,supplying obsolete and hard-to-find components to meet their specific needs.

With the principle of “Quality Parts,Customers Priority,Honest Operation,and Considerate Service”,our business mainly focus on the distribution of electronic components. Line cards we deal with include Microchip,ALPS,ROHM,Xilinx,Pulse,ON,Everlight and Freescale. Main products comprise IC,Modules,Potentiometer,IC Socket,Relay,Connector.Our parts cover such applications as commercial,industrial, and automotives areas.

We are looking forward to setting up business relationship with you and hope to provide you with the best service and solution. Let us make a better world for our industry!



Contact us

Tel: +86-755-8981 8866 Fax: +86-755-8427 6832

Email & Skype: info@chipsmall.com Web: www.chipsmall.com

Address: A1208, Overseas Decoration Building, #122 Zhenhua RD., Futian, Shenzhen, China



74LVC8T595

Dual supply 8-bit serial-in/serial-out or parallel-out shift register; 3-state

Rev. 1 — 9 May 2017

Product data sheet

1 General description

The 74LVC8T595 is an 8-bit serial-in/serial or parallel-out shift register with a storage register and 3-state outputs. Both the shift and storage register have separate clocks. Data is shifted on the positive-going transitions of the SHCP input. The data in the shift register is transferred to the storage register on a positive-going transition of the STCP input. If both clocks are connected together, the shift register is always one clock pulse ahead of the storage register.

$V_{CC(A)}$ and $V_{CC(B)}$ can be supplied at any voltage between 1.1 V and 5.5 V making the device suitable for translating between any of the voltage nodes (1.2 V, 1.5 V, 1.8 V, 2.5 V, 3.3 V and 5.0 V). Pins \overline{MR} , SHCP, STCP, \overline{OE} , DS and Q7S are referenced to $V_{CC(A)}$ and pins Qn are referenced to $V_{CC(B)}$.

The device is fully specified for partial power-down applications using I_{OFF} . The I_{OFF} circuitry disables the output, preventing any damaging backflow current through the device when it is powered down. In suspend mode when $V_{CC(A)}$ is at GND level, the Qn outputs are in the high-impedance OFF-state.

2 Features and benefits

- Wide supply voltage range:
 - $V_{CC(A)}$: 1.1 V to 5.5 V
 - $V_{CC(B)}$: 1.1 V to 5.5 V
- High noise immunity
- Complies with JEDEC standards:
 - JESD8-12A (1.1 V to 1.3 V)
 - JESD8-11A (1.4 V to 1.6 V)
 - JESD8-7 (1.65 V to 1.95 V)
 - JESD8-5 (2.3 V to 2.7 V)
 - JESD8C (3.0 V to 3.6 V)
 - JESD12-6 (4.5 V to 5.5 V)
- ESD protection:
 - HBM ANSI/ESDA/JEDEC JS-001 Class 3A exceeds 4000V
 - CDM JESD22-C101E exceeds 1000 V
- Suspend mode
- Latch-up performance exceeds 100 mA per JESD 78 Class II
- ± 24 mA output drive ($V_{CC(A)} = V_{CC(B)} = 3.0$ V)
- Inputs accept voltages up to 5.5 V
- I_{OFF} circuitry provides partial Power-down mode operation
- Multiple package options
- Specified from -40 °C to $+85$ °C and -40 °C to $+125$ °C

3 Ordering information

Table 1. Ordering information

Type number	Package		Description	Version
	Temperature range	Name		
74LVC8T595PW	-40 °C to +125 °C	TSSOP20	plastic thin shrink small outline package; 20 leads; body width 4.4 mm	SOT360-1
74LVC8T595BQ	-40 °C to +125 °C	DHVQFN20	plastic dual in-line compatible thermal enhanced very thin quad flat package; no leads; 20 terminals; body 2.5 x 4.5 x 0.85 mm	SOT764-1

4 Functional diagram

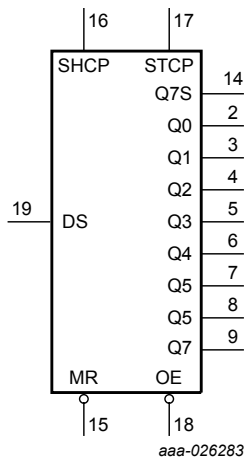

Figure 1. Logic symbol

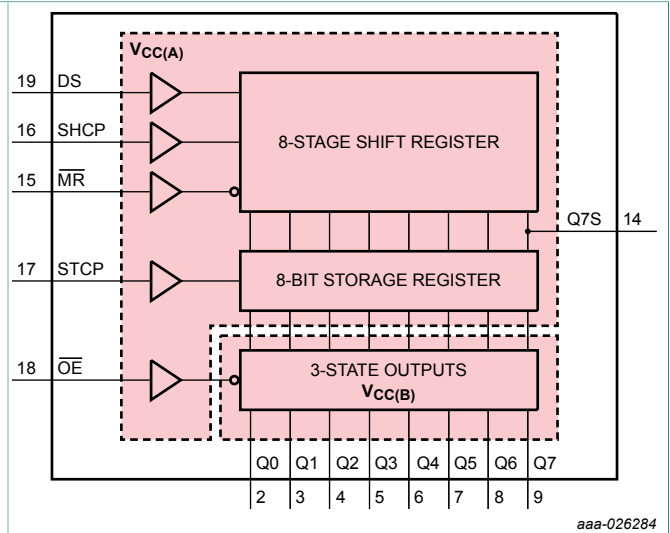
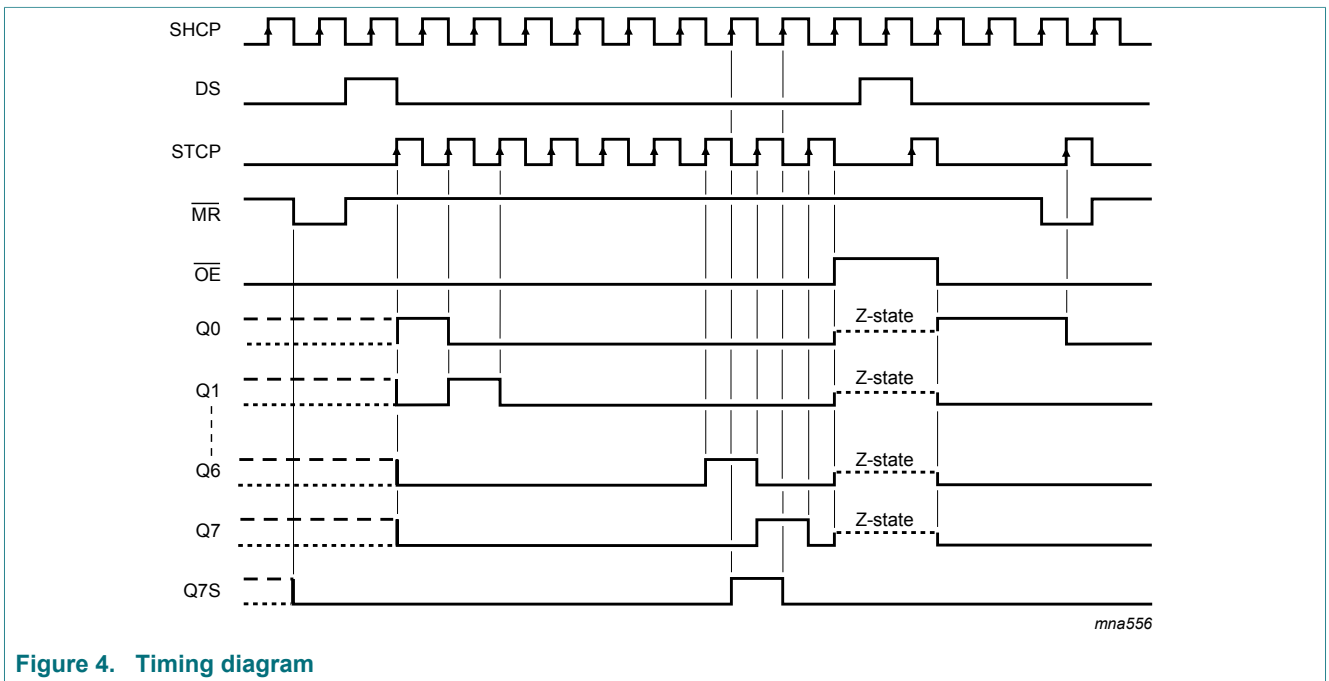
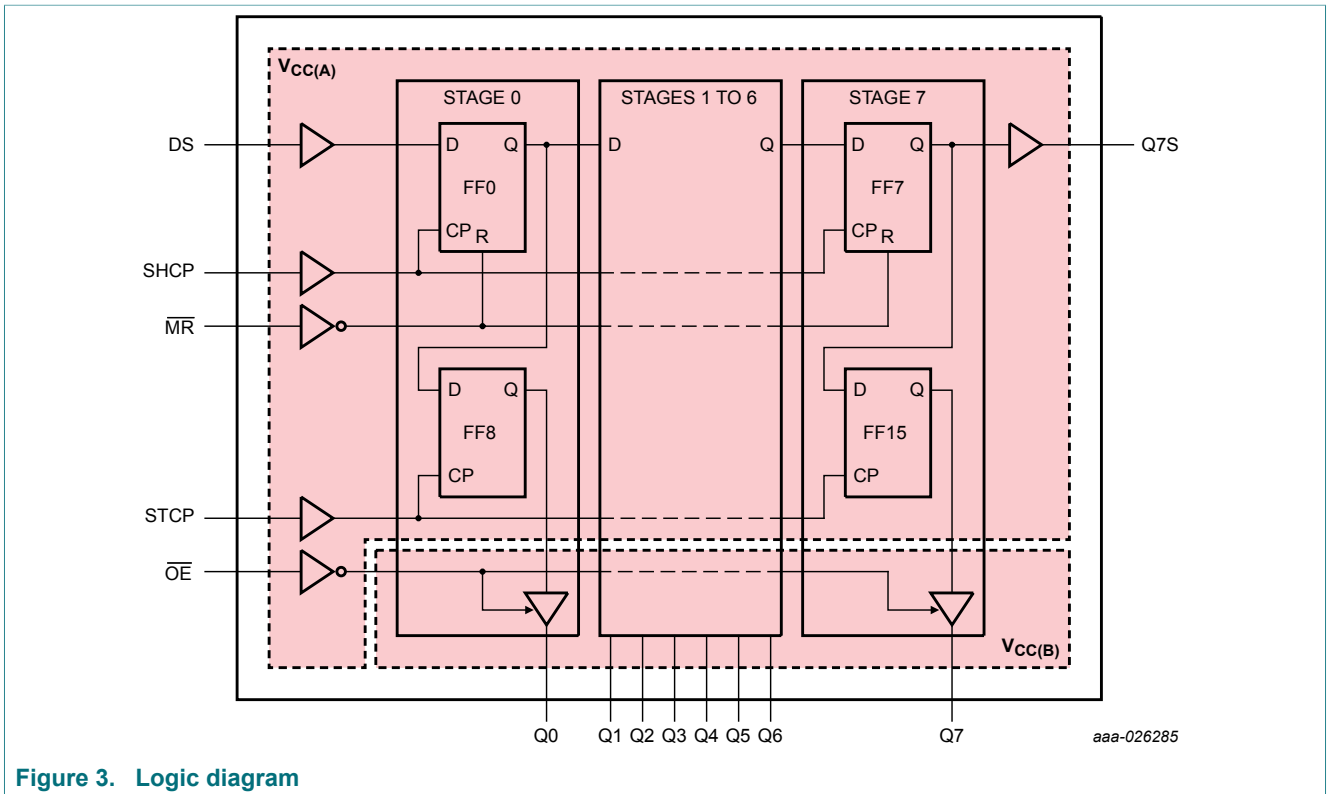
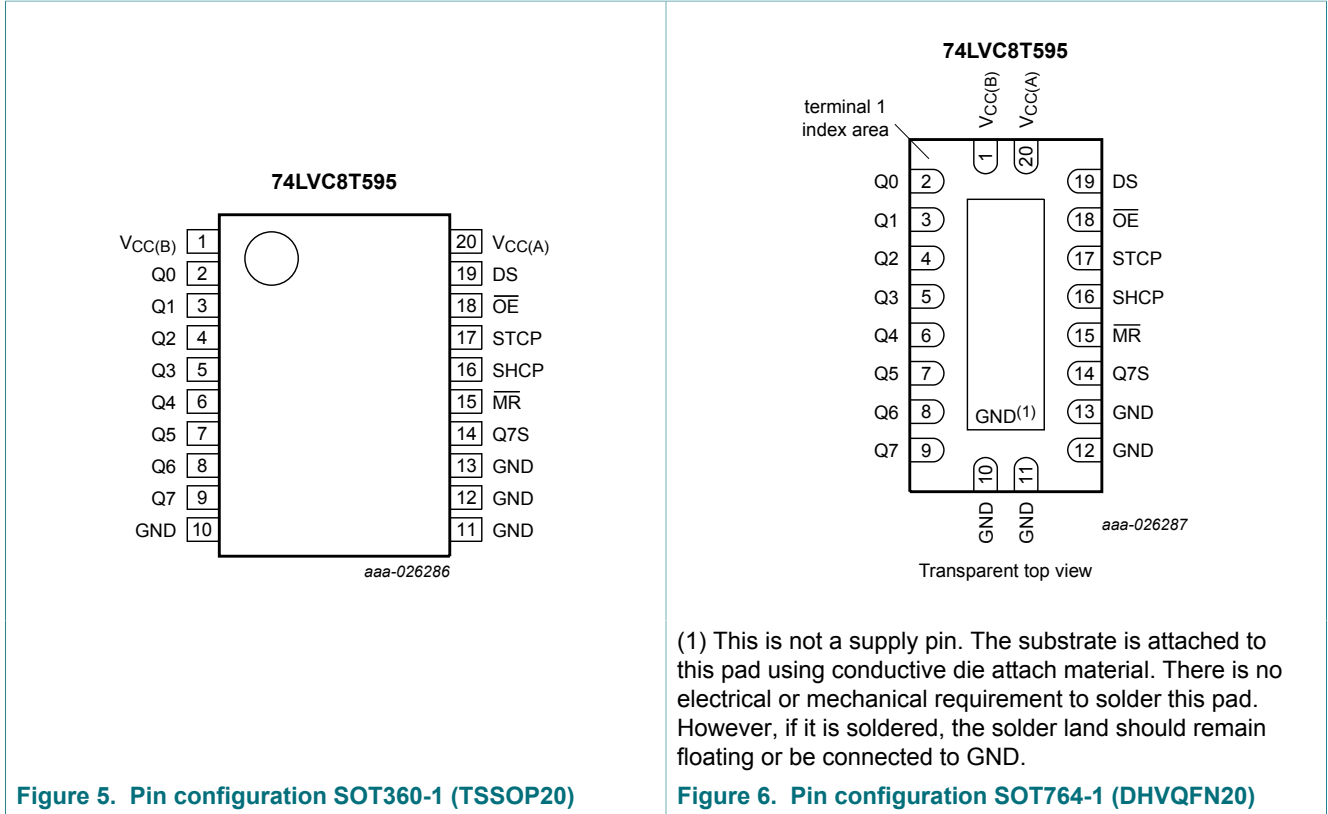

Figure 2. Functional diagram



5 Pinning information

5.1 Pinning



5.2 Pin description

Table 2. Pin description

Symbol	Pin	Description
V _{CC(B)}	1	supply voltage B (Q _n outputs)
Q0, Q1, Q2, Q3, Q4, Q5, Q6, Q7	2, 3, 4, 5, 6, 7, 8, 9	data output
GND	10, 11, 12, 13	ground (0 V)
Q7S	14	serial data output
$\overline{\text{MR}}$	15	master reset input (active LOW)
SHCP	16	shift register clock input
STCP	17	storage register clock input
$\overline{\text{OE}}$	18	output enable input (active LOW)
DS	19	serial data input
V _{CC(A)}	20	supply voltage A ($\overline{\text{MR}}$, SHCP, STCP, $\overline{\text{OE}}$, DS inputs and Q7S output)

6 Functional description

Table 3. Function table ^[1]

Supply voltage	Input				Output			Function
	$V_{CC(A)}, V_{CC(B)}$	SHCP	STCP	OE	MR	DS	Q7S	
1.2 V to 5.5 V	X	X	L	L	X	L	NC	a LOW-state on \overline{MR} only affects the shift register
1.2 V to 5.5 V	X	↑	L	L	X	L	L	empty shift register loaded into storage register
1.2 V to 5.5 V	X	X	H	L	X	L	Z	shift register clear; parallel outputs in high-impedance OFF-state
1.2 V to 5.5 V	↑	X	L	H	H	Q6S	NC	logic HIGH-state shifted into shift register stage 0. Contents of all shift register stages shifted through, e.g. previous state of stage 6 (internal Q6S) appears on the serial output (Q7S).
1.2 V to 5.5 V	X	↑	L	H	X	NC	QnS	contents of shift register stages (internal QnS) are transferred to the storage register and parallel output stages
1.2 V to 5.5 V	↑	↑	L	H	X	Q6S	QnS	contents of shift register shifted through; previous contents of the shift register is transferred to the storage register and the parallel output stages
GND ^[2]	X	X	X	X	X	X	Z	suspend mode

- [1] H = HIGH voltage state;
 L = LOW voltage state;
 ↑ = LOW-to-HIGH transition;
 X = don't care;
 NC = no change;
 Z = high-impedance OFF-state.

- [2] When $V_{CC(A)}$ is at GND level, the device goes into suspend mode.

7 Limiting values

Table 4. Limiting values

In accordance with the Absolute Maximum Rating System (IEC 60134). Voltages are referenced to GND (ground = 0 V).

Symbol	Parameter	Conditions	Min	Max	Unit
$V_{CC(A)}$	supply voltage A		-0.5	+6.5	V
$V_{CC(B)}$	supply voltage B		-0.5	+6.5	V
I_{IK}	input clamping current	$V_I < 0$ V	-50	-	mA
V_I	input voltage	[1]	-0.5	+6.5	V
I_{OK}	output clamping current	$V_O < 0$ V	-50	-	mA
V_O	output voltage	Active mode [1] [2] [3]	-0.5	$V_{CCO} + 0.5$	V
		Suspend or 3-state mode [1]	-0.5	+6.5	V
I_O	output current	$V_O = 0$ V to V_{CCO} [2]	-	± 50	mA
I_{CC}	supply current	$I_{CC(A)}$ or $I_{CC(B)}$	-	100	mA
I_{GND}	ground current		-100	-	mA
T_{stg}	storage temperature		-65	+150	°C
P_{tot}	total power dissipation	$T_{amb} = -40$ °C to +125 °C [4]	-	500	mW

[1] The minimum input voltage ratings and output voltage ratings may be exceeded if the input and output current ratings are observed.

[2] V_{CCO} is the supply voltage associated with the output.

[3] $V_{CCO} + 0.5$ V should not exceed 6.5 V

[4] For TSSOP20 package: above 60 °C the value of P_{tot} derates linearly with 5.5 mW/K.
For DHVQFN20 package: above 60 °C the value of P_{tot} derates linearly with 4.5 mW/K.

8 Recommended operating conditions

Table 5. Recommended operating conditions

Symbol	Parameter	Conditions	Min	Max	Unit
$V_{CC(A)}$	supply voltage A		1.1	5.5	V
$V_{CC(B)}$	supply voltage B		1.1	5.5	V
V_I	input voltage		0	5.5	V
V_O	output voltage	Active mode [1]	0	V_{CCO}	V
		Suspend or 3-state mode	0	5.5	V
T_{amb}	ambient temperature		-40	+125	°C
$\Delta t/\Delta V$	input transition rise and fall rate	$V_{CC(A)} = 1.1$ V to 1.3 V	-	20	ns/V
		$V_{CC(A)} = 1.4$ V to 1.95 V	-	20	ns/V
		$V_{CC(A)} = 2.3$ V to 2.7 V	-	20	ns/V
		$V_{CC(A)} = 3$ V to 3.6 V	-	10	ns/V
		$V_{CC(A)} = 4.5$ V to 5.5 V	-	5	ns/V

[1] V_{CCO} is the supply voltage associated with the output.

9 Static characteristics

Table 6. Typical static characteristics at $T_{amb} = 25\text{ °C}$

At recommended operating conditions; voltages are referenced to GND (ground = 0 V).

Symbol	Parameter	Conditions	Min	Typ	Max	Unit	
V_{OH}	HIGH-level output voltage	$V_I = V_{IH}$ or V_{IL}					
		$I_O = -3\text{ mA}$; $V_{CCO} = 1.2\text{ V}$	[1]	-	1.09	-	V
V_{OL}	LOW-level output voltage	$V_I = V_{IH}$ or V_{IL}					
		$I_O = 3\text{ mA}$; $V_{CCO} = 1.2\text{ V}$	[1]	-	0.07	-	V
I_I	input leakage current	\overline{MR} , SHCP, STCP, \overline{OE} and DS inputs; $V_I = 0\text{ V}$ to 5.5 V ; $V_{CC(A)} = 1.1\text{ V}$ to 5.5 V	-	-	± 1	μA	
I_{OZ}	OFF-state output current	Qn outputs; $V_O = 0\text{ V}$ or $V_{CC(B)}$					
		$V_{CC(B)} = 1.1\text{ V}$ to 5.5 V	-	-	± 1	μA	
		suspend mode; $V_{CC(A)} = 0\text{ V}$; $V_{CC(B)} = 5.5\text{ V}$	-	-	± 1	μA	
I_{OFF}	power-off leakage current	inputs, Q7S output; V_I or $V_O = 0\text{ V}$ to 5.5 V ; $V_{CC(A)} = 0\text{ V}$; $V_{CC(B)} = 1.1\text{ V}$ to 5.5 V	[1]	-	-	± 1	μA
		Qn outputs; V_I or $V_O = 0\text{ V}$ to 5.5 V ; $V_{CC(B)} = 0\text{ V}$; $V_{CC(A)} = 1.1\text{ V}$ to 5.5 V		-	-	± 1	μA
C_I	input capacitance	\overline{MR} , SHCP, STCP, \overline{OE} and DS inputs; $V_I = 0\text{ V}$ or 3.3 V ; $V_{CC(A)} = V_{CC(B)} = 3.3\text{ V}$	-	3	-	pF	

[1] V_{CCO} is the supply voltage associated with the output.

Table 7. Static characteristics

At recommended operating conditions; voltages are referenced to GND (ground = 0 V).

Symbol	Parameter	Conditions	-40 °C to +85 °C		-40 °C to +125 °C		Unit
			Min	Max	Min	Max	
V _{IH}	HIGH-level input voltage	V _{CC(A)} = 1.1 V to 1.3 V	0.65V _{CC(A)}	-	0.65V _{CC(A)}	-	V
		V _{CC(A)} = 1.4 V to 1.6 V	0.65V _{CC(A)}	-	0.65V _{CC(A)}	-	V
		V _{CC(A)} = 1.65 V to 1.95 V	0.65V _{CC(A)}	-	0.65V _{CC(A)}	-	V
		V _{CC(A)} = 2.3 V to 2.7 V	1.7	-	1.7	-	V
		V _{CC(A)} = 3.0 V to 3.6 V	2.0	-	2.0	-	V
		V _{CC(A)} = 4.5 V to 5.5 V	0.7V _{CC(A)}	-	0.7V _{CC(A)}	-	V
V _{IL}	LOW-level input voltage	V _{CC(A)} = 1.1 V to 1.3 V	-	0.35V _{CC(A)}	-	0.35V _{CC(A)}	V
		V _{CC(A)} = 1.4 V to 1.6 V	-	0.35V _{CC(A)}	-	0.35V _{CC(A)}	V
		V _{CC(A)} = 1.65 V to 1.95 V	-	0.35V _{CC(A)}	-	0.35V _{CC(A)}	V
		V _{CC(A)} = 2.3 V to 2.7 V	-	0.7	-	0.7	V
		V _{CC(A)} = 3.0 V to 3.6 V	-	0.8	-	0.8	V
		V _{CC(A)} = 4.5 V to 5.5 V	-	0.3V _{CC(A)}	-	0.3V _{CC(A)}	V
V _{OH}	HIGH-level output voltage	V _I = V _{IH} [1]					
		I _O = -100 µA; V _{CCO} = 1.1 V to 4.5 V	V _{CCO} - 0.1	-	V _{CCO} - 0.1	-	V
		I _O = -2 mA; V _{CCO} = 1.1 V	0.825	-	0.825	-	V
		I _O = -6 mA; V _{CCO} = 1.4 V	1.0	-	1.0	-	V
		I _O = -8 mA; V _{CCO} = 1.65 V	1.2	-	1.2	-	V
		I _O = -12 mA; V _{CCO} = 2.3 V	1.9	-	1.9	-	V
		I _O = -24 mA; V _{CCO} = 3.0 V	2.4	-	2.4	-	V
		I _O = -24 mA; V _{CCO} = 4.5 V	3.85	-	3.85	-	V
		I _O = -32 mA; V _{CCO} = 4.5 V	3.8	-	3.8	-	V
V _{OL}	LOW-level output voltage	V _I = V _{IL} [1]					
		I _O = 100 µA; V _{CCO} = 1.1 V to 4.5 V	-	0.1	-	0.1	V
		I _O = 2 mA; V _{CCO} = 1.1 V	-	0.275	-	0.275	V
		I _O = 6 mA; V _{CCO} = 1.4 V	-	0.3	-	0.3	V
		I _O = 8 mA; V _{CCO} = 1.65 V	-	0.45	-	0.45	V
		I _O = 12 mA; V _{CCO} = 2.3 V	-	0.3	-	0.3	V
		I _O = 24 mA; V _{CCO} = 3.0 V	-	0.55	-	0.55	V
		I _O = 24 mA; V _{CCO} = 4.5 V	-	0.50	-	0.50	V
I _O = 32 mA; V _{CCO} = 4.5 V	-	0.55	-	0.55	V		

Dual supply 8-bit serial-in/serial-out or parallel-out shift register; 3-state

Symbol	Parameter	Conditions	-40 °C to +85 °C		-40 °C to +125 °C		Unit
			Min	Max	Min	Max	
I_I	input leakage current	$V_I = 0 \text{ V to } 5.5 \text{ V};$ $V_{CC(A)} = 1.1 \text{ V to } 5.5 \text{ V}$	-	± 2	-	± 10	μA
I_{OZ}	OFF-state output current	Qn outputs; $V_O = 0 \text{ V or } V_{CC(B)}$					
		$V_{CC(B)} = 1.1 \text{ V to } 5.5 \text{ V}$	-	± 2	-	± 10	μA
		suspend mode; $V_{CC(A)} = 0 \text{ V}; V_{CC(B)} = 5.5 \text{ V}$	-	± 2	-	± 10	μA
I_{OFF}	power-off leakage current	inputs, Q7S output; $V_I \text{ or } V_O = 0 \text{ V to } 5.5 \text{ V};$ $V_{CC(A)} = 0 \text{ V};$ $V_{CC(B)} = 1.1 \text{ V to } 5.5 \text{ V}$	-	± 2	-	± 10	μA
		Qn outputs; $V_I \text{ or } V_O = 0 \text{ V to } 5.5 \text{ V};$ $V_{CC(B)} = 0 \text{ V};$ $V_{CC(A)} = 1.1 \text{ V to } 5.5 \text{ V}$	-	± 2	-	± 10	μA
I_{CC}	supply current	$V_{CC(A)}$ domain; $V_I = 0 \text{ V or } V_{CC(A)}; I_O = 0 \text{ A}$					
		$V_{CC(A)}, V_{CC(B)} = 1.1 \text{ V to } 5.5 \text{ V}$	-	2	-	5	μA
		$V_{CC(A)} = 5.5 \text{ V}; V_{CC(B)} = 0 \text{ V}$	-	2	-	5	μA
		$V_{CC(A)} = 0 \text{ V}; V_{CC(B)} = 5.5 \text{ V}$	-1	-	-2	-	μA
		$V_{CC(B)}$ domain; $V_I = 0 \text{ V or } V_{CC(A)}; I_O = 0 \text{ A}$					
		$V_{CC(A)}, V_{CC(B)} = 1.1 \text{ V to } 5.5 \text{ V}$	-	9	-	24	μA
		$V_{CC(B)} = 5.5 \text{ V}; V_{CC(A)} = 0 \text{ V}$	-	9	-	24	μA
$V_{CC(B)} = 0 \text{ V}; V_{CC(A)} = 5.5 \text{ V}$	-1	-	-2	-	μA		
ΔI_{CC}	additional supply current	per input; $V_{CC(A)}, V_{CC(B)} = 3.0 \text{ V to } 5.5 \text{ V}$					
		MR, SHCP, STCP, \overline{OE} inputs; one input at $V_{CC(A)} - 0.6 \text{ V};$ DS input at $V_{CC(A)}$ or GND; Qn = open	-	50	-	75	μA
		DS input at $V_{CC(A)} - 0.6 \text{ V};$ Qn = open	-	50	-	75	μA

[1] V_{CCO} is the supply voltage associated with the output.

10 Dynamic characteristics

Table 8. Typical power dissipation capacitance at $V_{CC(A)} = V_{CC(B)}$ and $T_{amb} = 25\text{ °C}$ [1] [2]

Voltages are referenced to GND (ground = 0 V).

Symbol	Parameter	Conditions	$V_{CC(A)}$ and $V_{CC(B)}$						Unit
			1.2 V	1.5 V	1.8 V	2.5 V	3.3 V	5.0 V	
C_{PD}	power dissipation capacitance	inputs	31	31	32	33	36	43	pF
		outputs	105	104	103	101	99	98	pF

[1] C_{PD} is used to determine the dynamic power dissipation (P_D in μW).

$$P_D = C_{PD} \times V_{CC}^2 \times f_i \times N + \Sigma(C_L \times V_{CC}^2 \times f_o) \text{ where:}$$

f_i = input frequency in MHz;

f_o = output frequency in MHz;

C_L = load capacitance in pF;

V_{CC} = supply voltage in V;

N = number of inputs switching;

$\Sigma(C_L \times V_{CC}^2 \times f_o)$ = sum of the outputs.

[2] $f_i = 10\text{ MHz}$; $V_i = \text{GND to } V_{CC}$; $t_r = t_f = 1\text{ ns}$; $C_L = 0\text{ pF}$; $R_L = \infty\ \Omega$.

Table 9. Dynamic characteristics

Voltages are referenced to GND (ground = 0 V); for test circuit see [Figure 13](#); for waveforms see [Figure 7](#) up to [Figure 12](#).

Symbol	Parameter	Conditions	$V_{CC(A)}$									Unit
			1.2 V \pm 0.1 V			1.5 V \pm 0.1 V			1.8 V \pm 0.15 V			
			Min	Typ	Max	Min	Typ	Max	Min	Typ	Max	
$T_{amb} = +25\text{ °C}$; $V_{CC(B)} = 1.1\text{ V to } 5.5\text{ V}$												
t_{pd}	propagation delay	SHCP to Q7S [1]	5.8	21.3	38.9	4.5	14.2	20.9	3.7	10.9	16.7	ns
t_{PHL}	HIGH to LOW propagation delay	$\overline{\text{MR}}$ to Q7S	5.9	22.7	42.1	4.5	14.8	18.9	3.7	11.2	14.7	ns
t_W	pulse width	SHCP, STCP HIGH or LOW	6.9	1.9	-	3.5	1.4	-	2.6	1.1	-	ns
		$\overline{\text{MR}}$ LOW	12.4	3.5	-	5.6	2.1	-	3.9	1.5	-	ns
t_{su}	set-up time	DS to SHCP	3.0	1.1	-	2.6	0.5	-	2.3	0.3	-	ns
		$\overline{\text{MR}}$ to STCP	15.5	7.2	-	7.9	4.0	-	5.5	2.8	-	ns
		SHCP to STCP	13.5	5.4	-	6.5	3.0	-	4.9	2.1	-	ns
t_h	hold time	DS to SHCP	3.0	± 0.4	-	2.0	± 0.2	-	1.5	± 0.1	-	ns
t_{rec}	recovery time	$\overline{\text{MR}}$ to SHCP	2.0	-0.4	-	1.5	-0.2	-	1.3	-0.2	-	ns
f_{max}	maximum frequency	SHCP	45	73	-	75	99	-	90	120	-	MHz

[1] t_{pd} is the same as t_{PHL} , t_{PLH} .

Dual supply 8-bit serial-in/serial-out or parallel-out shift register; 3-state

Table 10. Dynamic characteristics

Voltages are referenced to GND (ground = 0 V); for test circuit see Figure 13; for waveforms see Figure 7 up to Figure 12.

Symbol	Parameter	Conditions	$V_{CC(A)}$									Unit
			2.5 V ± 0.2 V			3.3 V ± 0.3 V			5.0 V ± 0.5 V			
			Min	Typ	Max	Min	Typ	Max	Min	Typ	Max	
$T_{amb} = +25\text{ °C}; V_{CC(B)} = 1.1\text{ V to }5.5\text{ V}$												
t_{pd}	propagation delay	SHCP to Q7S ^[1]	2.7	7.3	11.5	2.3	5.6	9.1	1.9	4.1	6.6	ns
t_{PHL}	HIGH to LOW propagation delay	\overline{MR} to Q7S	2.9	7.4	10.0	2.4	5.7	7.9	2.1	4.4	6.1	ns
t_W	pulse width	SHCP, STCP HIGH or LOW	1.6	0.7	-	1.4	0.6	-	1.0	0.5	-	ns
		\overline{MR} LOW	2.5	1.0	-	1.6	0.8	-	1.4	0.6	-	ns
t_{su}	set-up time	DS to SHCP	1.9	0.2	-	1.5	0.1	-	1.1	0.1	-	ns
		\overline{MR} to STCP	3.2	1.7	-	2.4	1.3	-	2.2	1.1	-	ns
		SHCP to STCP	2.8	1.2	-	1.9	0.9	-	1.4	0.6	-	ns
t_h	hold time	DS to SHCP	1.5	±0.1	-	1.0	±0.1	-	1.0	±0.1	-	ns
t_{rec}	recovery time	\overline{MR} to SHCP	1.0	-0.1	-	1.0	-0.1	-	1.0	-0.1	-	ns
f_{max}	maximum frequency	SHCP	135	160	-	175	194	-	195	250	-	MHz

[1] t_{pd} is the same as t_{PHL} , t_{PLH} .

Table 11. Dynamic characteristics for temperature +25 °C ^[1]

Voltages are referenced to GND (ground = 0 V); for test circuit see Figure 13; for waveforms see Figure 7 up to Figure 12.

Symbol	Parameter	Conditions	$V_{CC(B)}$									Unit
			1.2 V ± 0.1 V			1.5 V ± 0.1 V			1.8 V ± 0.15 V			
			Min	Typ	Max	Min	Typ	Max	Min	Typ	Max	
$V_{CC(A)} = 1.2\text{ V} \pm 0.1\text{ V}$												
t_{pd}	propagation delay	STCP to Qn	6.2	23.7	46.4	5.3	19.1	35.4	4.8	16.9	31.6	ns
t_{dis}	disable time	\overline{OE} to Qn	3.6	12.7	25.1	3.0	9.7	15.6	3.1	9.0	14.4	ns
t_{en}	enable time	\overline{OE} to Qn	5.8	20.9	40.0	4.6	15.1	26.2	3.9	12.6	21.7	ns
f_{max}	maximum frequency	STCP	35	69	-	45	88	-	45	110	-	MHz
$t_{sk(o)}$	output skew time	Q0 to Q7 ^[2]	-	-	3.0	-	-	2.3	-	-	1.9	ns

Dual supply 8-bit serial-in/serial-out or parallel-out shift register; 3-state

Symbol	Parameter	Conditions	$V_{CC(B)}$									Unit
			1.2 V ± 0.1 V			1.5 V ± 0.1 V			1.8 V ± 0.15 V			
			Min	Typ	Max	Min	Typ	Max	Min	Typ	Max	
$V_{CC(A)} = 1.5 \text{ V} \pm 0.1 \text{ V}$												
t_{pd}	propagation delay	STCP to Qn	5.7	20.2	32.1	4.9	15.5	23.3	4.3	13.3	20.0	ns
t_{dis}	disable time	\overline{OE} to Qn	3.4	11.4	20.1	2.8	8.3	13.2	2.8	7.6	11.7	ns
t_{en}	enable time	\overline{OE} to Qn	5.5	19.9	38.7	4.2	13.9	24.1	3.6	11.3	19.3	ns
f_{max}	maximum frequency	STCP	45	73	-	70	95	-	90	120	-	MHz
$t_{sk(o)}$	output skew time	Q0 to Q7 ^[2]	-	-	2.7	-	-	2.0	-	-	1.7	ns
$V_{CC(A)} = 1.8 \text{ V} \pm 0.15 \text{ V}$												
t_{pd}	propagation delay	STCP to Qn	5.4	18.7	30.3	4.5	14.0	21.4	4	11.8	18.3	ns
t_{dis}	disable time	\overline{OE} to Qn	3.2	10.8	19.4	2.6	7.8	12.6	2.6	7.0	11.0	ns
t_{en}	enable time	\overline{OE} to Qn	5.4	19.4	38.1	4.1	13.4	23.7	3.5	10.7	18.7	ns
f_{max}	maximum frequency	STCP	45	75	-	70	98	-	90	125	-	MHz
$t_{sk(o)}$	output skew time	Q0 to Q7 ^[2]	-	-	2.7	-	-	2.0	-	-	1.6	ns
$V_{CC(A)} = 2.5 \text{ V} \pm 0.2 \text{ V}$												
t_{pd}	propagation delay	STCP to Qn	5.1	17.3	28.3	4.2	12.6	19.5	3.6	10.4	16.3	ns
t_{dis}	disable time	\overline{OE} to Qn	3.0	10.3	18.8	2.4	7.2	11.9	2.4	6.4	10.3	ns
t_{en}	enable time	\overline{OE} to Qn	5.3	18.9	37.7	4.1	13.0	23.3	3.4	10.2	18.1	ns
f_{max}	maximum frequency	STCP	45	76	-	70	100	-	90	128	-	MHz
$t_{sk(o)}$	output skew time	Q0 to Q7 ^[2]	-	-	2.6	-	-	2.0	-	-	1.6	ns
$V_{CC(A)} = 3.3 \text{ V} \pm 0.3 \text{ V}$												
t_{pd}	propagation delay	STCP to Qn	4.9	16.7	27.6	4.0	12.0	18.7	3.4	9.8	15.4	ns
t_{dis}	disable time	\overline{OE} to Qn	3.0	10.0	18.4	2.3	6.9	11.4	2.3	6.1	10.0	ns
t_{en}	enable time	\overline{OE} to Qn	5.3	18.8	37.6	4.1	12.9	23.0	3.4	10.1	18.0	ns
f_{max}	maximum frequency	STCP	45	76	-	70	101	-	90	130	-	MHz
$t_{sk(o)}$	output skew time	Q0 to Q7 ^[2]	-	-	2.6	-	-	2.0	-	-	1.6	ns
$V_{CC(A)} = 5.0 \text{ V} \pm 0.5 \text{ V}$												
t_{pd}	propagation delay	STCP to Qn	4.8	16.1	27.5	3.9	11.4	18.0	3.3	9.2	14.8	ns
t_{dis}	disable time	\overline{OE} to Qn	2.8	9.6	19.4	2.2	6.6	11.3	2.3	5.9	9.6	ns
t_{en}	enable time	\overline{OE} to Qn	5.4	18.7	38.3	4.1	12.8	23.1	3.4	10.1	18.3	ns
f_{max}	maximum frequency	STCP	45	77	-	70	102	-	90	132	-	MHz
$t_{sk(o)}$	output skew time	Q0 to Q7 ^[2]	-	-	2.7	-	-	2.0	-	-	1.6	ns

[1] t_{pd} is the same as t_{PLH} and t_{PHL} ; t_{dis} is the same as t_{PLZ} and t_{PHZ} ; t_{en} is the same as t_{PZL} and t_{PZH} .

[2] Skew between any two outputs of the same package switching in the same direction. This parameter is guaranteed by design.

Dual supply 8-bit serial-in/serial-out or parallel-out shift register; 3-state

Table 12. Dynamic characteristics for temperature +25 °C [1]

Voltages are referenced to GND (ground = 0 V); for test circuit see Figure 13; for waveforms see Figure 7 up to Figure 12.

Symbol	Parameter	Conditions	$V_{CC(B)}$									Unit
			2.5 V ± 0.2 V			3.3 V ± 0.3 V			5.0 V ± 0.5 V			
			Min	Typ	Max	Min	Typ	Max	Min	Typ	Max	
$V_{CC(A)} = 1.2 \text{ V} \pm 0.1 \text{ V}$												
t_{pd}	propagation delay	STCP to Qn	4.2	14.5	27.9	3.8	13.4	26.3	3.5	12.4	24.9	ns
t_{dis}	disable time	\overline{OE} to Qn	2.6	7.4	12.0	2.9	7.7	12.4	2.4	6.6	11.3	ns
t_{en}	enable time	\overline{OE} to Qn	3.3	10.1	16.8	2.9	9.2	15.8	2.7	8.9	15.9	ns
f_{max}	maximum frequency	STCP	45	131	-	45	139	-	45	144	-	MHz
$t_{sk(o)}$	output skew time	Q0 to Q7 [2]	-	-	1.4	-	-	1.2	-	-	1.0	ns
$V_{CC(A)} = 1.5 \text{ V} \pm 0.1 \text{ V}$												
t_{pd}	propagation delay	STCP to Qn	3.7	10.9	16.2	3.3	9.7	14.5	3.0	8.7	13.0	ns
t_{dis}	disable time	\overline{OE} to Qn	2.2	6.0	9.2	2.6	6.2	9.4	2.1	5.0	8.1	ns
t_{en}	enable time	\overline{OE} to Qn	2.9	8.6	14.1	2.6	7.5	12.1	2.4	6.7	10.6	ns
f_{max}	maximum frequency	STCP	130	144	-	130	187	-	130	224	-	MHz
$t_{sk(o)}$	output skew time	Q0 to Q7 [2]	-	-	1.2	-	-	1.0	-	-	0.7	ns
$V_{CC(A)} = 1.8 \text{ V} \pm 0.15 \text{ V}$												
t_{pd}	propagation delay	STCP to Qn	3.4	9.4	14.4	3.0	8.2	12.6	2.7	7.2	10.9	ns
t_{dis}	disable time	\overline{OE} to Qn	2.0	5.3	8.3	2.4	5.5	8.5	1.9	4.3	7.2	ns
t_{en}	enable time	\overline{OE} to Qn	2.7	8.0	13.3	2.4	6.7	11.1	2.2	5.8	9.4	ns
f_{max}	maximum frequency	STCP	130	151	-	165	197	-	205	237	-	MHz
$t_{sk(o)}$	output skew time	Q0 to Q7 [2]	-	-	1.2	-	-	0.9	-	-	0.7	ns
$V_{CC(A)} = 2.5 \text{ V} \pm 0.2 \text{ V}$												
t_{pd}	propagation delay	STCP to Qn	3.0	7.9	12.4	2.6	6.7	10.5	2.3	5.7	8.8	ns
t_{dis}	disable time	\overline{OE} to Qn	1.9	4.6	7.5	2.2	4.8	7.5	1.7	3.5	6.0	ns
t_{en}	enable time	\overline{OE} to Qn	2.7	7.4	12.6	2.3	6.0	10.2	2.0	4.9	8.2	ns
f_{max}	maximum frequency	STCP	130	156	-	165	210	-	215	252	-	MHz
$t_{sk(o)}$	output skew time	Q0 to Q7 [2]	-	-	1.2	-	-	0.9	-	-	0.7	ns
$V_{CC(A)} = 3.3 \text{ V} \pm 0.3 \text{ V}$												
t_{pd}	propagation delay	STCP to Qn	2.8	7.3	11.5	2.4	6.1	9.6	2.1	5.0	7.9	ns
t_{dis}	disable time	\overline{OE} to Qn	1.8	4.4	7.1	2.1	4.5	7.1	1.6	3.2	5.5	ns
t_{en}	enable time	\overline{OE} to Qn	2.6	7.2	12.3	2.3	5.8	10.0	2.0	4.6	7.8	ns
f_{max}	maximum frequency	STCP	130	159	-	165	213	-	215	255	-	MHz
$t_{sk(o)}$	output skew time	Q0 to Q7 [2]	-	-	1.2	-	-	0.9	-	-	0.7	ns

Dual supply 8-bit serial-in/serial-out or parallel-out shift register; 3-state

Symbol	Parameter	Conditions	$V_{CC(B)}$									Unit
			2.5 V \pm 0.2 V			3.3 V \pm 0.3 V			5.0 V \pm 0.5 V			
			Min	Typ	Max	Min	Typ	Max	Min	Typ	Max	
$V_{CC(A)} = 5.0 \text{ V} \pm 0.5 \text{ V}$												
t_{pd}	propagation delay	STCP to Qn	2.7	6.8	10.9	2.3	5.5	8.9	1.8	4.4	7.2	ns
t_{dis}	disable time	\overline{OE} to Qn	1.7	4.1	6.8	2.0	4.3	6.7	1.4	2.9	5.1	ns
t_{en}	enable time	\overline{OE} to Qn	2.7	7.2	12.4	2.3	5.8	10.0	2.0	4.6	7.7	ns
f_{max}	maximum frequency	STCP	130	159	-	165	213	-	215	254	-	MHz
$t_{sk(o)}$	output skew time	Q0 to Q7 ^[2]	-	-	1.1	-	-	0.9	-	-	0.7	ns

[1] t_{pd} is the same as t_{PLH} and t_{PHL} ; t_{dis} is the same as t_{PLZ} and t_{PHZ} ; t_{en} is the same as t_{PZL} and t_{PZH} .

[2] Skew between any two outputs of the same package switching in the same direction. This parameter is guaranteed by design.

Table 13. Dynamic characteristics

Voltages are referenced to GND (ground = 0 V); for test circuit see [Figure 13](#); for waveforms see [Figure 7](#) up to [Figure 12](#).

Symbol	Parameter	Conditions	$V_{CC(A)}$												Unit
			1.2 V ± 0.1 V		1.5 V ± 0.1 V		1.8 V ± 0.15 V		2.5 V ± 0.2 V		3.3 V ± 0.3 V		5.0 V ± 0.5 V		
			Min	Max	Min	Max	Min	Max	Min	Max	Min	Max	Min	Max	
$T_{amb} = -40\text{ °C to }+85\text{ °C}; V_{CC(B)} = 1.1\text{ V to }5.5\text{ V}$															
t_{pd}	propagation delay	SHCP to Q7S ^[1]	3.4	42.1	2.7	22.1	2.1	17.7	1.5	12.4	1.3	9.8	1.0	7.2	ns
t_{PHL}	HIGH to LOW propagation delay	\overline{MR} to Q7S	3.6	43.6	2.7	20.2	2.2	16.0	1.7	11.0	1.4	8.7	1.3	6.6	ns
t_w	pulse width	SHCP, STCP HIGH or LOW	7.8	-	4.8	-	3.3	-	2.0	-	1.7	-	1.3	-	ns
		\overline{MR} LOW	12.8	-	6.2	-	4.4	-	2.8	-	2.3	-	1.4	-	ns
t_{su}	set-up time	DS to SHCP	4.5	-	3.0	-	2.6	-	2.3	-	1.9	-	1.5	-	ns
		\overline{MR} to STCP	16.5	-	9.1	-	6.1	-	3.6	-	2.9	-	2.3	-	ns
		SHCP to STCP	13.5	-	7.7	-	5.4	-	3.2	-	2.3	-	1.8	-	ns
t_h	hold time	DS to SHCP	3.0	-	2.0	-	1.5	-	1.5	-	1.0	-	1.0	-	ns
t_{rec}	recovery time	\overline{MR} to SHCP	2.2	-	1.7	-	1.5	-	1.2	-	1.2	-	1.2	-	ns
f_{max}	maximum frequency	SHCP	40	-	70	-	90	-	130	-	160	-	175	-	MHz

Dual supply 8-bit serial-in/serial-out or parallel-out shift register; 3-state

Symbol	Parameter	Conditions	$V_{CC(A)}$												Unit
			1.2 V ± 0.1 V		1.5 V ± 0.1 V		1.8 V ± 0.15 V		2.5 V ± 0.2 V		3.3 V ± 0.3 V		5.0 V ± 0.5 V		
			Min	Max	Min	Max	Min	Max	Min	Max	Min	Max	Min	Max	
$T_{amb} = -40\text{ °C to }+125\text{ °C}; V_{CC(B)} = 1.1\text{ V to }5.5\text{ V}$															
t_{pd}	propagation delay	SHCP to Q7S ^[1]	3.4	42.1	2.7	22.7	2.1	18.3	1.5	12.9	1.3	10.3	1.0	7.6	ns
t_{PHL}	HIGH to LOW propagation delay	\overline{MR} to Q7S	3.6	44.3	2.7	21.0	2.2	16.7	1.7	11.5	1.4	9.1	1.3	7.0	ns
t_W	pulse width	SHCP, STCP HIGH or LOW	8.4	-	5.3	-	3.8	-	2.5	-	1.9	-	1.4	-	ns
		\overline{MR} LOW	13.3	-	6.9	-	5.2	-	3.1	-	2.4	-	1.6	-	ns
t_{su}	set-up time	DS to SHCP	4.5	-	3.0	-	2.6	-	2.3	-	1.9	-	1.5	-	ns
		\overline{MR} to STCP	16.5	-	9.5	-	6.8	-	4.2	-	3.1	-	2.4	-	ns
		SHCP to STCP	14.2	-	8.0	-	6.2	-	3.6	-	2.3	-	1.8	-	ns
t_h	hold time	DS to SHCP	3.5	-	2.5	-	2.0	-	2.0	-	1.5	-	1.2	-	ns
t_{rec}	recovery time	\overline{MR} to SHCP	2.4	-	1.9	-	1.7	-	1.4	-	1.4	-	1.4	-	ns
f_{max}	maximum frequency	SHCP	40	-	70	-	85	-	120	-	150	-	170	-	MHz

[1] t_{pd} is the same as t_{PHL} , t_{PLH} .

Table 14. Dynamic characteristics for temperature range -40 °C to +85 °C ^[1]

Voltages are referenced to GND (ground = 0 V); for test circuit see [Figure 13](#); for waveforms see [Figure 7](#) up to [Figure 12](#).

Symbol	Parameter	Conditions	$V_{CC(B)}$												Unit
			1.2 V ± 0.1 V		1.5 V ± 0.1 V		1.8 V ± 0.15 V		2.5 V ± 0.2 V		3.3 V ± 0.3 V		5.0 V ± 0.5 V		
			Min	Max	Min	Max	Min	Max	Min	Max	Min	Max	Min	Max	
$V_{CC(A)} = 1.2 \text{ V} \pm 0.1 \text{ V}$															
t_{pd}	propagation delay	STCP to Qn	3.8	48.3	3.2	36.7	2.8	33.0	2.4	29.2	2.2	27.7	2.0	26.0	ns
t_{dis}	disable time	\overline{OE} to Qn	2.1	26.6	1.8	17.2	1.8	15.8	1.5	13.1	1.8	13.4	1.4	12.3	ns
t_{en}	enable time	\overline{OE} to Qn	3.5	42.1	2.7	27.0	2.2	22.6	1.9	18.0	1.7	17.0	1.6	17.2	ns
f_{max}	maximum frequency	STCP	30	-	40	-	40	-	40	-	40	-	40	-	MHz
$t_{sk(o)}$	output skew time	Q0 to Q7 ^[2]	-	3.5	-	2.5	-	2.0	-	1.5	-	1.2	-	1.0	ns
$V_{CC(A)} = 1.5 \text{ V} \pm 0.1 \text{ V}$															
t_{pd}	propagation delay	STCP to Qn	3.5	34.2	2.9	25.6	2.5	22.4	2.1	18.5	1.9	16.8	1.7	15.1	ns
t_{dis}	disable time	\overline{OE} to Qn	2.0	21.6	1.7	14.8	1.7	13.1	1.3	10.3	1.6	10.4	1.3	9.0	ns
t_{en}	enable time	\overline{OE} to Qn	3.3	38.9	2.6	25.0	2.1	20.3	1.7	15.1	1.5	13.2	1.4	11.7	ns
f_{max}	maximum frequency	STCP	40	-	65	-	80	-	105	-	105	-	105	-	MHz
$t_{sk(o)}$	output skew time	Q0 to Q7 ^[2]	-	3.1	-	2.2	-	1.8	-	1.3	-	1.0	-	0.8	ns
$V_{CC(A)} = 1.8 \text{ V} \pm 0.15 \text{ V}$															
t_{pd}	propagation delay	STCP to Qn	3.3	31.8	2.7	23.4	2.3	20.4	1.9	16.4	1.7	14.5	1.5	12.8	ns
t_{dis}	disable time	\overline{OE} to Qn	1.9	20.9	1.5	14.2	1.6	12.4	1.2	9.4	1.4	9.4	1.1	8.0	ns
t_{en}	enable time	\overline{OE} to Qn	3.3	38.6	2.4	24.5	2.0	19.7	1.6	14.4	1.4	12.1	1.3	10.5	ns
f_{max}	maximum frequency	STCP	40	-	65	-	80	-	120	-	145	-	155	-	MHz
$t_{sk(o)}$	output skew time	Q0 to Q7 ^[2]	-	3.1	-	2.2	-	1.8	-	1.2	-	1.0	-	0.8	ns

Dual supply 8-bit serial-in/serial-out or parallel-out shift register; 3-state

Symbol	Parameter	Conditions	$V_{CC(B)}$												Unit
			1.2 V ± 0.1 V		1.5 V ± 0.1 V		1.8 V ± 0.15 V		2.5 V ± 0.2 V		3.3 V ± 0.3 V		5.0 V ± 0.5 V		
			Min	Max	Min	Max	Min	Max	Min	Max	Min	Max	Min	Max	
$V_{CC(A)} = 2.5 V \pm 0.2 V$															
t_{pd}	propagation delay	STCP to Qn	3.1	29.6	2.5	21.2	2.1	18.1	1.7	14.0	1.5	12.1	1.3	10.2	ns
t_{dis}	disable time	\overline{OE} to Qn	1.8	20.2	1.4	13.2	1.4	11.6	1.1	8.5	1.3	8.3	1.0	6.6	ns
t_{en}	enable time	\overline{OE} to Qn	3.2	37.7	2.4	24.0	2.0	19.1	1.5	13.5	1.3	11.1	1.2	9.0	ns
f_{max}	maximum frequency	STCP	40	-	65	-	80	-	120	-	145	-	180	-	MHz
$t_{sk(o)}$	output skew time	Q0 to Q7 ^[2]	-	3.1	-	2.2	-	1.8	-	1.2	-	1.0	-	0.7	ns
$V_{CC(A)} = 3.3 V \pm 0.3 V$															
t_{pd}	propagation delay	STCP to Qn	3.0	29.1	2.4	20.3	2.0	17.2	1.6	13.0	1.4	11.0	1.2	9.1	ns
t_{dis}	disable time	\overline{OE} to Qn	1.7	19.7	1.3	13.0	1.4	11.2	1.0	8.1	1.3	7.9	0.9	6.0	ns
t_{en}	enable time	\overline{OE} to Qn	3.2	38.1	2.4	23.7	2.0	19.0	1.5	13.3	1.3	10.7	1.2	8.5	ns
f_{max}	maximum frequency	STCP	40	-	65	-	80	-	120	-	145	-	190	-	MHz
$t_{sk(o)}$	output skew time	Q0 to Q7 ^[2]	-	3.0	-	2.2	-	1.8	-	1.2	-	1.0	-	0.7	ns
$V_{CC(A)} = 5.0 V \pm 0.5 V$															
t_{pd}	propagation delay	STCP to Qn	2.9	29.1	2.3	19.6	1.9	16.3	1.5	12.2	1.3	10.2	1.1	8.2	ns
t_{dis}	disable time	\overline{OE} to Qn	1.6	20.6	1.3	12.6	1.3	10.9	0.9	7.7	1.2	7.5	0.8	5.6	ns
t_{en}	enable time	\overline{OE} to Qn	3.3	38.9	2.5	23.8	2.0	19.1	1.6	13.3	1.4	10.6	1.2	8.3	ns
f_{max}	maximum frequency	STCP	40	-	65	-	80	-	120	-	145	-	190	-	MHz
$t_{sk(o)}$	output skew time	Q0 to Q7 ^[2]	-	3.0	-	2.2	-	1.7	-	1.2	-	0.9	-	0.7	ns

[1] t_{pd} is the same as t_{PLH} and t_{PHL} ; t_{dis} is the same as t_{PLZ} and t_{PHZ} ; t_{en} is the same as t_{PZL} and t_{PZH} .

[2] Skew between any two outputs of the same package switching in the same direction. This parameter is guaranteed by design.

Table 15. Dynamic characteristics for temperature range -40 °C to +125 °C [1]

Voltages are referenced to GND (ground = 0 V); for test circuit see Figure 13; for waveforms see Figure 7 up to Figure 12.

Symbol	Parameter	Conditions	$V_{CC(B)}$												Unit
			1.2 V ± 0.1 V		1.5 V ± 0.1 V		1.8 V ± 0.15 V		2.5 V ± 0.2 V		3.3 V ± 0.3 V		5.0 V ± 0.5 V		
			Min	Max	Min	Max	Min	Max	Min	Max	Min	Max	Min	Max	
$V_{CC(A)} = 1.1 \text{ V to } 1.3 \text{ V}$															
t_{pd}	propagation delay	STCP to Qn	3.8	48.3	3.2	37.4	2.8	34.0	2.4	30.4	2.2	28.6	2.0	27.0	ns
t_{dis}	disable time	\overline{OE} to Qn	2.1	27.6	1.8	18.0	1.8	16.5	1.5	13.7	1.8	14.1	1.4	12.8	ns
t_{en}	enable time	\overline{OE} to Qn	3.5	42.1	2.7	27.6	2.2	23.2	1.9	18.6	1.7	17.8	1.6	18.0	ns
f_{max}	maximum frequency	STCP	30	-	40	-	40	-	40	-	40	-	40	-	MHz
$t_{sk(o)}$	output skew time	Q0 to Q7 [2]	-	3.6	-	2.6	-	2.1	-	1.5	-	1.3	-	1.0	ns
$V_{CC(A)} = 1.4 \text{ V to } 1.6 \text{ V}$															
t_{pd}	propagation delay	STCP to Qn	3.5	34.4	2.9	26.3	2.5	23.3	2.1	19.6	1.9	17.7	1.7	16.1	ns
t_{dis}	disable time	\overline{OE} to Qn	2.0	22.7	1.7	15.7	1.7	14.0	1.3	11.0	1.6	11.0	1.3	9.5	ns
t_{en}	enable time	\overline{OE} to Qn	3.3	38.9	2.6	25.5	2.1	20.8	1.7	15.8	1.5	13.8	1.4	12.3	ns
f_{max}	maximum frequency	STCP	40	-	65	-	75	-	95	-	95	-	95	-	MHz
$t_{sk(o)}$	output skew time	Q0 to Q7 [2]	-	3.1	-	2.2	-	1.8	-	1.3	-	1.0	-	0.8	ns
$V_{CC(A)} = 1.65 \text{ V to } 1.95 \text{ V}$															
t_{pd}	propagation delay	STCP to Qn	3.3	32.1	2.7	24.1	2.3	21.1	1.9	17.3	1.7	15.3	1.5	13.6	ns
t_{dis}	disable time	\overline{OE} to Qn	1.9	21.9	1.5	14.9	1.6	13.2	1.2	10.1	1.4	10.0	1.1	8.4	ns
t_{en}	enable time	\overline{OE} to Qn	3.3	38.6	2.4	24.8	2.0	20.3	1.6	14.9	1.4	12.7	1.3	11.0	ns
f_{max}	maximum frequency	STCP	40	-	65	-	75	-	105	-	140	-	140	-	MHz
$t_{sk(o)}$	output skew time	Q0 to Q7 [2]	-	3.1	-	2.2	-	1.8	-	1.2	-	1.0	-	0.8	ns

Dual supply 8-bit serial-in/serial-out or parallel-out shift register; 3-state

Symbol	Parameter	Conditions	$V_{CC(B)}$												Unit
			1.2 V ± 0.1 V		1.5 V ± 0.1 V		1.8 V ± 0.15 V		2.5 V ± 0.2 V		3.3 V ± 0.3 V		5.0 V ± 0.5 V		
			Min	Max	Min	Max	Min	Max	Min	Max	Min	Max	Min	Max	
$V_{CC(A)} = 2.3 \text{ V to } 2.7 \text{ V}$															
t_{pd}	propagation delay	STCP to Qn	3.1	29.7	2.5	21.8	2.1	18.8	1.7	14.7	1.5	12.7	1.3	10.8	ns
t_{dis}	disable time	\overline{OE} to Qn	1.8	21.2	1.4	14.2	1.4	12.4	1.1	9.1	1.3	8.8	1.0	7.0	ns
t_{en}	enable time	\overline{OE} to Qn	3.2	37.7	2.4	24.4	2.0	19.7	1.5	14.1	1.3	11.6	1.2	9.4	ns
f_{max}	maximum frequency	STCP	40	-	65	-	75	-	105	-	140	-	175	-	MHz
$t_{sk(o)}$	output skew time	Q0 to Q7 ^[2]	-	3.1	-	2.2	-	1.8	-	1.2	-	1.0	-	0.7	ns
$V_{CC(A)} = 3.0 \text{ V to } 3.6 \text{ V}$															
t_{pd}	propagation delay	STCP to Qn	3.0	29.1	2.4	20.8	2.0	17.7	1.6	13.5	1.4	11.6	1.2	9.6	ns
t_{dis}	disable time	\overline{OE} to Qn	1.7	20.9	1.3	13.8	1.4	12.1	1.0	8.7	1.3	8.3	0.9	6.4	ns
t_{en}	enable time	\overline{OE} to Qn	3.2	38.1	2.4	24.3	2.0	19.5	1.5	13.7	1.3	11.2	1.2	8.9	ns
f_{max}	maximum frequency	STCP	40	-	65	-	75	-	105	-	140	-	175	-	MHz
$t_{sk(o)}$	output skew time	Q0 to Q7 ^[2]	-	3.0	-	2.2	-	1.8	-	1.2	-	1.0	-	0.7	ns
$V_{CC(A)} = 4.5 \text{ V to } 5.5 \text{ V}$															
t_{pd}	propagation delay	STCP to Qn	2.9	29.1	2.3	20.0	1.9	16.7	1.5	12.7	1.3	10.6	1.1	9.0	ns
t_{dis}	disable time	\overline{OE} to Qn	1.6	21.7	1.3	13.6	1.3	11.7	0.9	8.3	1.2	7.9	0.8	6.0	ns
t_{en}	enable time	\overline{OE} to Qn	3.3	38.9	2.5	24.3	2.0	19.5	1.6	13.8	1.4	11.0	1.2	8.6	ns
f_{max}	maximum frequency	STCP	40	-	65	-	75	-	105	-	140	-	175	-	MHz
$t_{sk(o)}$	output skew time	Q0 to Q7 ^[2]	-	3.0	-	2.2	-	1.7	-	1.2	-	0.9	-	0.7	ns

[1] t_{pd} is the same as t_{PLH} and t_{PHL} ; t_{dis} is the same as t_{PLZ} and t_{PHZ} ; t_{en} is the same as t_{PZL} and t_{PZH} .

[2] Skew between any two outputs of the same package switching in the same direction. This parameter is guaranteed by design.

10.1 Waveforms and test circuit

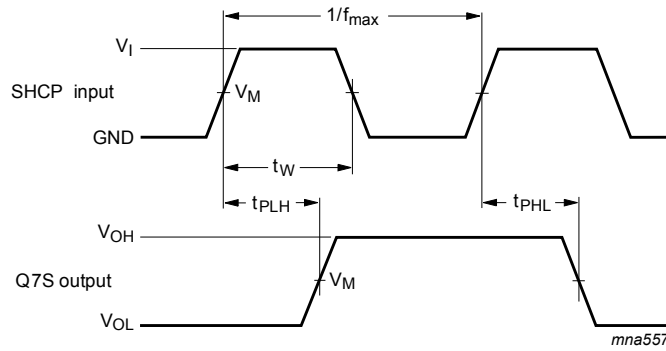

Measurement points are given in [Table 16](#).

V_{OL} and V_{OH} are typical output voltage levels that occur with the output load.

Figure 7. The shift clock (SHCP) to serial data output (Q7S) propagation delays, the shift clock pulse width and maximum shift clock frequency

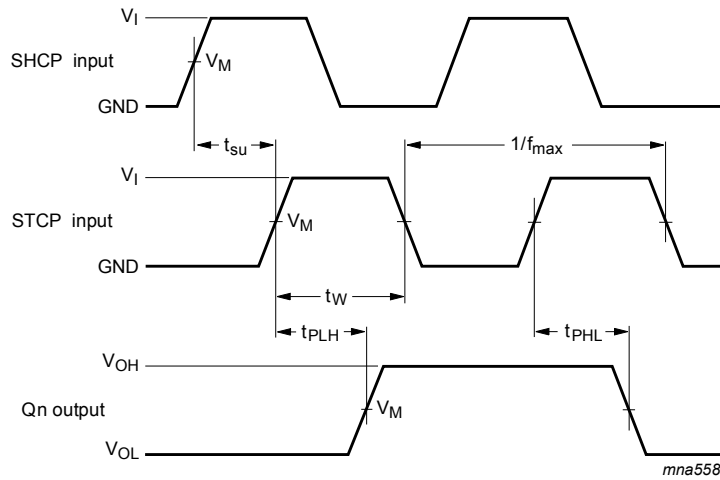

Measurement points are given in [Table 16](#).

V_{OL} and V_{OH} are typical output voltage levels that occur with the output load.

Figure 8. The storage clock (STCP) to parallel data output (Qn) propagation delays, the storage clock pulse width and the shift clock to storage clock set-up time

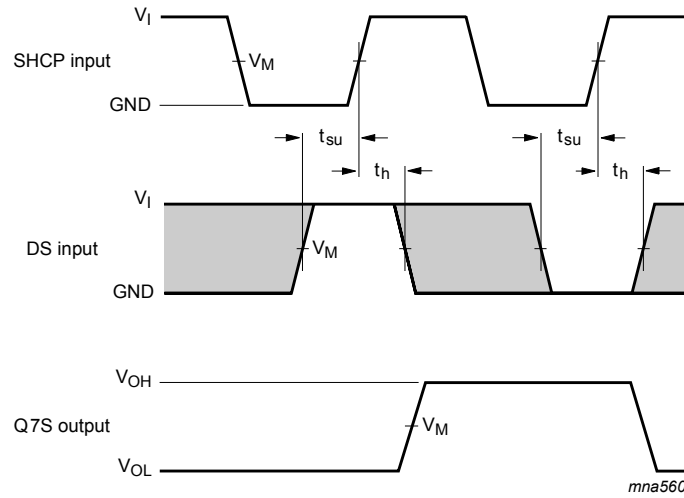

Measurement points are given in [Table 16](#).

V_{OL} and V_{OH} are typical output voltage levels that occur with the output load.

Figure 9. The data set-up and hold times for the serial data input (DS)

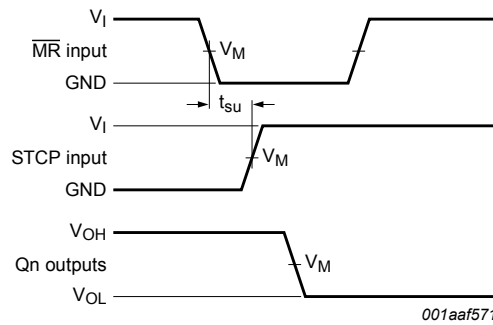

Measurement points are given in [Table 16](#).

V_{OL} and V_{OH} are typical output voltage levels that occur with the output load.

Figure 10. The master reset (\overline{MR}) to storage clock (STCP) set-up time

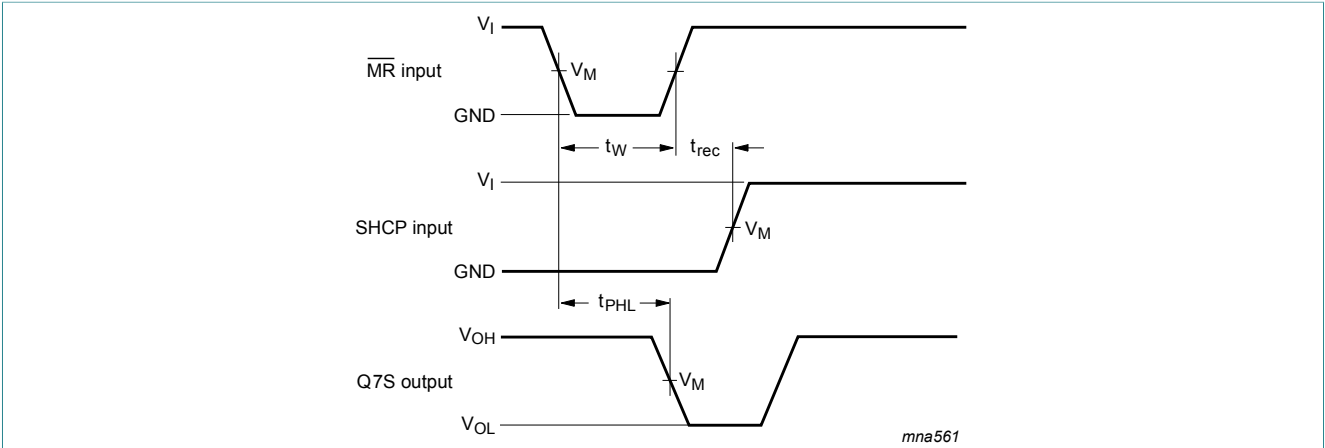

Measurement points are given in [Table 16](#).

V_{OL} and V_{OH} are typical output voltage levels that occur with the output load.

Figure 11. The master reset (\overline{MR}) pulse width, the master reset to serial data output (Q7S) propagation delays and the master reset to shift clock (SHCP) recovery time

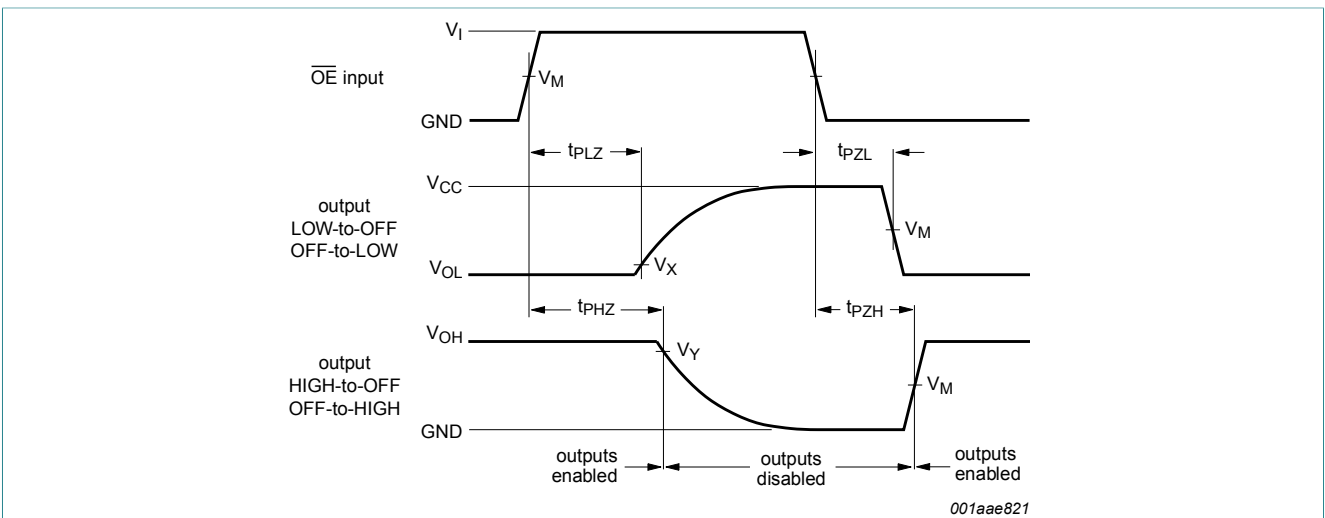

Measurement points are given in [Table 16](#).

V_{OL} and V_{OH} are typical output voltage drops that occur with the output load.

Figure 12. 3-state enable and disable times

Table 16. Measurement points

Supply voltage	Input	Output			
$V_{CC(A)}, V_{CC(B)}$	V_M	$V_M (Q_n)$	$V_M (Q7S)$	V_X	V_Y
1.1 V to 1.6 V	$0.5V_{CC(A)}$	$0.5V_{CC(B)}$	$0.5V_{CC(A)}$	$V_{OL} + 0.1 V$	$V_{OH} - 0.1 V$
1.65 V to 2.7 V	$0.5V_{CC(A)}$	$0.5V_{CC(B)}$	$0.5V_{CC(A)}$	$V_{OL} + 0.15 V$	$V_{OH} - 0.15 V$
3.0 V to 5.5 V	$0.5V_{CC(A)}$	$0.5V_{CC(B)}$	$0.5V_{CC(A)}$	$V_{OL} + 0.3 V$	$V_{OH} - 0.3 V$

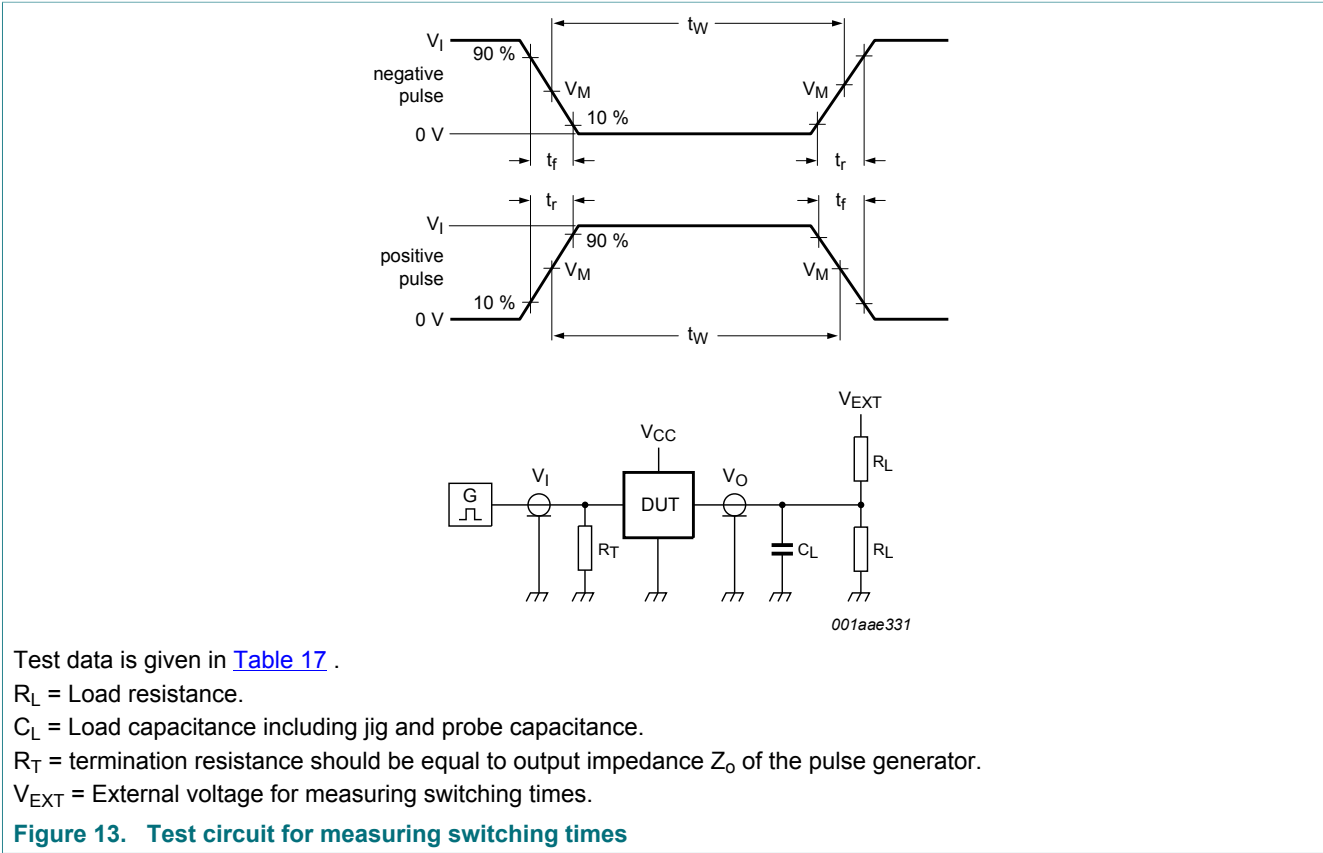

Table 17. Test data

Supply voltage	Input		Load		V_{EXT}		
$V_{CC(A)}, V_{CC(B)}$	V_I	$\Delta t/\Delta V$ [1]	C_L	R_L	t_{PLH}, t_{PHL}	t_{PZH}, t_{PHZ}	t_{PZL}, t_{PLZ}
1.1 V to 5.5 V	$V_{CC(A)}$	$\leq 1.0 \text{ ns/V}$	15 pF	2 k Ω	open	GND	$2V_{CC(B)}$

[1] $dV/dt \geq 1.0 \text{ V/ns}$

10.2 Typical propagation delay characteristics

