



Chipsmall Limited consists of a professional team with an average of over 10 year of expertise in the distribution of electronic components. Based in Hongkong, we have already established firm and mutual-benefit business relationships with customers from,Europe,America and south Asia,supplying obsolete and hard-to-find components to meet their specific needs.

With the principle of "Quality Parts,Customers Priority,Honest Operation,and Considerate Service",our business mainly focus on the distribution of electronic components. Line cards we deal with include Microchip,ALPS,ROHM,Xilinx,Pulse,ON,Everlight and Freescale. Main products comprise IC,Modules,Potentiometer,IC Socket,Relay,Connector.Our parts cover such applications as commercial,industrial, and automotives areas.

We are looking forward to setting up business relationship with you and hope to provide you with the best service and solution. Let us make a better world for our industry!



Contact us

Tel: +86-755-8981 8866 Fax: +86-755-8427 6832

Email & Skype: info@chipsmall.com Web: www.chipsmall.com

Address: A1208, Overseas Decoration Building, #122 Zhenhua RD., Futian, Shenzhen, China





3.3V CMOS 16-BIT BUS TRANSCEIVER WITH 3-STATE OUTPUTS AND 5 VOLT TOLERANT I/O

IDT74LVCR162245A

FEATURES:

- Typical $t_{sk(o)}$ (Output Skew) < 250ps
- ESD > 2000V per MIL-STD-883, Method 3015; > 200V using machine model (C = 200pF, R = 0)
- $V_{cc} = 3.3V \pm 0.3V$, Normal Range
- $V_{cc} = 2.7V$ to $3.6V$, Extended Range
- CMOS power levels (0.4 μ W typ. static)
- All inputs, outputs, and I/O are 5V tolerant
- Supports hot insertion
- Available in SSOP and TSSOP packages

DRIVE FEATURES:

- Balanced Output Drivers: $\pm 12mA$
- Low switching noise

APPLICATIONS:

- 5V and 3.3V mixed voltage systems
- Data communication and telecommunication systems

DESCRIPTION:

This 16-bit bus transceiver is built using advanced dual metal CMOS technology. This high-speed, low power transceiver is ideal for asynchronous communication between two busses (A and B). The Direction and Output Enable controls are designed to operate this device as either two independent 8-bit transceivers or one 16-bit transceiver. The direction control pin (DIR) controls the direction of data flow. The output enable pin (\overline{OE}) overrides the direction control and disables both ports. All inputs are designed with hysteresis for improved noise margin.

All pins can be driven from either 3.3V or 5V devices. This feature allows the use of this device as a translator in a mixed 3.3V/5V supply system.

The LVCR162245A has series resistors in the device output structure which will significantly reduce line noise when used with light loads. The driver has been designed to drive $\pm 12mA$ at the designated threshold levels.

FUNCTIONAL BLOCK DIAGRAM

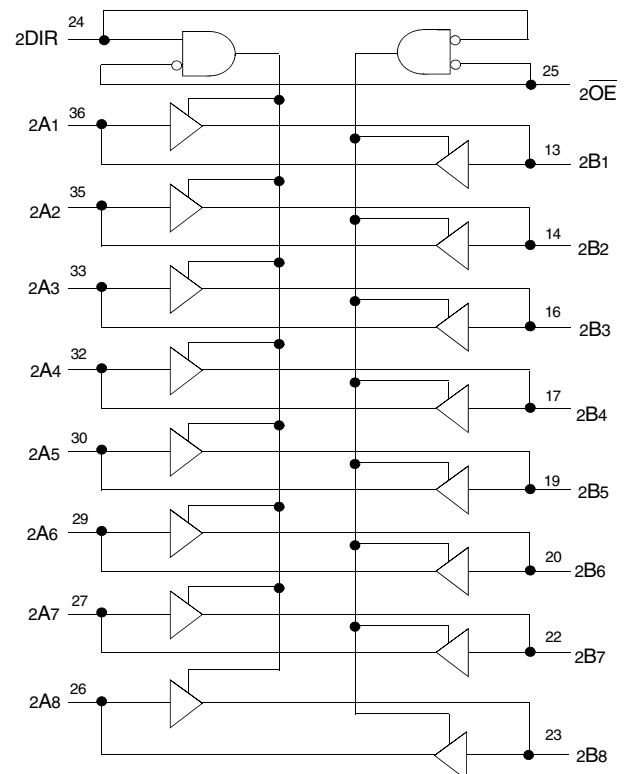
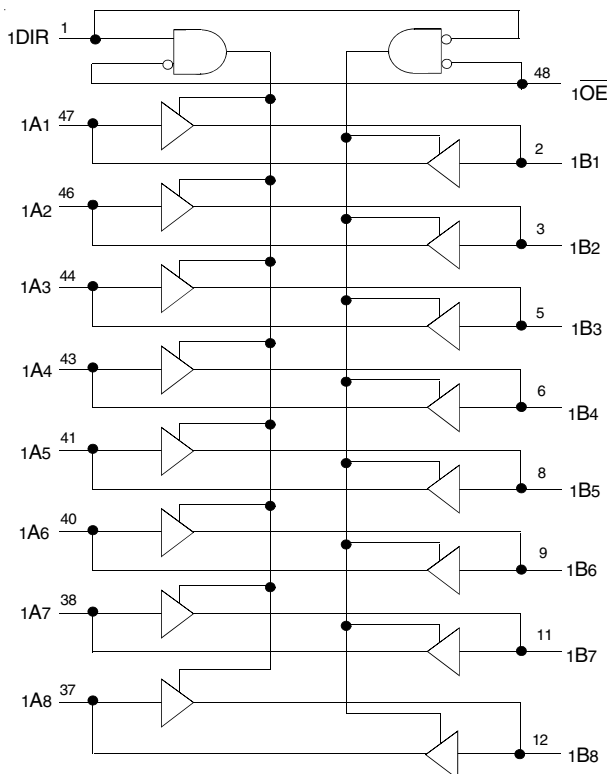

PIN CONFIGURATION

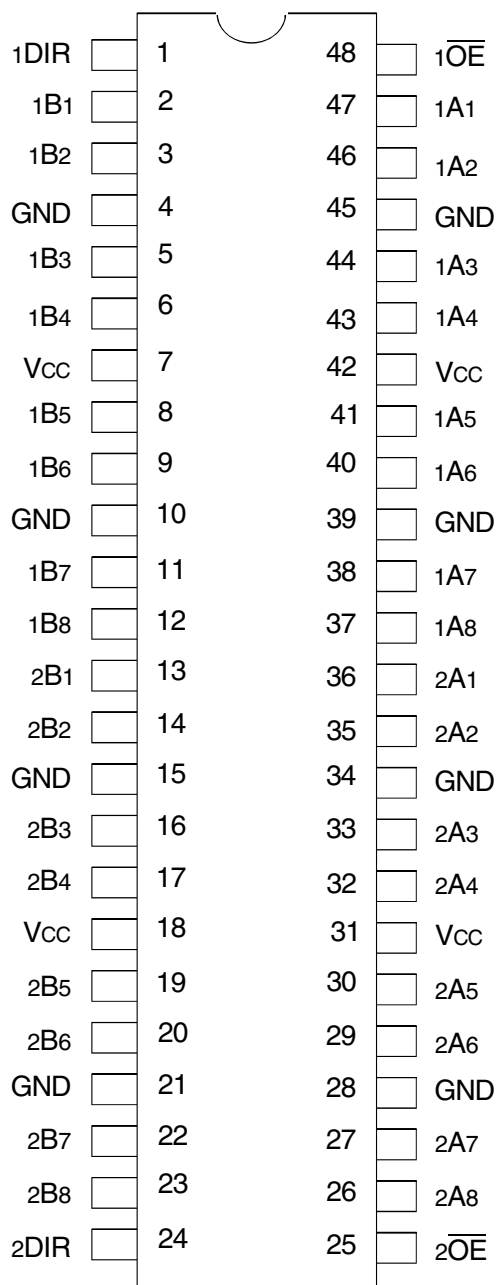

SSOP/ TSSOP
TOP VIEW

ABSOLUTE MAXIMUM RATINGS⁽¹⁾

Symbol	Description	Max	Unit
V _{TERM} ⁽²⁾	Terminal Voltage with Respect to GND	-0.5 to +6.5	V
V _{TERM} ⁽³⁾	Terminal Voltage with Respect to GND	-0.5 to +6.5	V
T _{STG}	Storage Temperature	-65 to +150	°C
I _{OUT}	DC Output Current	-50 to +50	mA
I _{IK} I _{OK}	Continuous Clamp Current, V _I < 0 or V _O < 0	-50	mA
I _{CC} I _{SS}	Continuous Current through each V _{CC} or GND	±100	mA

NOTES:

- Stresses greater than those listed under ABSOLUTE MAXIMUM RATINGS may cause permanent damage to the device. This is a stress rating only and functional operation of the device at these or any other conditions above those indicated in the operational sections of this specification is not implied. Exposure to absolute maximum rating conditions for extended periods may affect reliability.
- V_{CC} terminals.
- All terminals except V_{CC}.

CAPACITANCE (T_A = +25°C, F = 1.0MHz)

Symbol	Parameter ⁽¹⁾	Conditions	Typ.	Max.	Unit
C _{IN}	Input Capacitance	V _{IN} = 0V	4.5	6	pF
C _{OUT}	Output Capacitance	V _{OUT} = 0V	6.5	8	pF
C _{I/O}	I/O Port Capacitance	V _{IN} = 0V	6.5	8	pF

NOTE:

- As applicable to the device type.

PIN DESCRIPTION

Pin Names	Description
x \overline{OE}	Output Enable Input (Active LOW)
xDIR	Direction Control Input
xAx	Side A Inputs or 3-State Outputs
xBx	Side B Inputs or 3-State Outputs

FUNCTION TABLE (EACH 8-BIT SECTION)⁽¹⁾

Inputs		Outputs
x \overline{OE}	xDIR	
L	L	Bus B Data to Bus A
L	H	Bus A Data to Bus B
H	X	Isolation

NOTE:

- H = HIGH Voltage Level
X = Don't Care
L = LOW Voltage Level

DC ELECTRICAL CHARACTERISTICS OVER OPERATING RANGE

Following Conditions Apply Unless Otherwise Specified:

Operating Condition: TA = -40°C to +85°C

Symbol	Parameter	Test Conditions		Min.	Typ. ⁽¹⁾	Max.	Unit
VIH	Input HIGH Voltage Level	VCC = 2.3V to 2.7V		1.7	—	—	V
		VCC = 2.7V to 3.6V		2	—	—	
VIL	Input LOW Voltage Level	VCC = 2.3V to 2.7V		—	—	0.7	V
		VCC = 2.7V to 3.6V		—	—	0.8	
IIH IIL	Input Leakage Current	VCC = 3.6V	VI = 0 to 5.5V	—	—	±5	µA
IOZH IOZL	High Impedance Output Current (3-State Output pins)	VCC = 3.6V	VO = 0 to 5.5V	—	—	±10	µA
IOFF	Input/Output Power Off Leakage	VCC = 0V, VIN or VO ≤ 5.5V		—	—	±50	µA
VIK	Clamp Diode Voltage	VCC = 2.3V, IIN = -18mA		—	-0.7	-1.2	V
VH	Input Hysteresis	VCC = 3.3V		—	100	—	mV
ICCL ICCH ICCZ	Quiescent Power Supply Current	VCC = 3.6V	VIN = GND or VCC	—	—	10	µA
			3.6 ≤ VIN ≤ 5.5V ⁽²⁾	—	—	10	
ΔICC	Quiescent Power Supply Current Variation	One input at VCC - 0.6V, other inputs at VCC or GND		—	—	500	µA

NOTES:

1. Typical values are at VCC = 3.3V, +25°C ambient.
2. This applies in the disabled state only.

OUTPUT DRIVE CHARACTERISTICS

Symbol	Parameter	Test Conditions ⁽¹⁾		Min.	Max.	Unit
VOH	Output HIGH Voltage	VCC = 2.3V to 3.6V	IOH = -0.1mA	VCC - 0.2	—	V
		VCC = 2.3V	IOH = -4mA	1.9	—	
			IOH = -6mA	1.7	—	
		VCC = 2.7V	IOH = -4mA	2.2	—	
			IOH = -8mA	2	—	
		VCC = 3V	IOH = -6mA	2.4	—	
	IOH = -12mA	2	—			
VOL	Output LOW Voltage	VCC = 2.3V to 3.6V	IOL = 0.1mA	—	0.2	V
		VCC = 2.3V	IOL = 4mA	—	0.4	
			IOL = 6mA	—	0.55	
		VCC = 2.7V	IOL = 4mA	—	0.4	
			IOL = 8mA	—	0.6	
		VCC = 3V	IOL = 6mA	—	0.55	
	IOL = 12mA	—	0.8			

NOTE:

1. VIH and VIL must be within the min. or max. range shown in the DC ELECTRICAL CHARACTERISTICS OVER OPERATING RANGE table for the appropriate VCC range. TA = -40°C to +85°C.

OPERATING CHARACTERISTICS, $V_{CC} = 3.3V \pm 0.3V$, $T_A = 25^\circ C$

Symbol	Parameter	Test Conditions	Typical	Unit
CPD	Power Dissipation Capacitance per Transceiver Outputs enabled	$C_L = 0pF$, $f = 10MHz$	39	pF
CPD	Power Dissipation Capacitance per Transceiver Outputs disabled		4	

SWITCHING CHARACTERISTICS⁽¹⁾

Symbol	Parameter	$V_{CC} = 2.7V$		$V_{CC} = 3.3V \pm 0.3V$		Unit
		Min.	Max.	Min.	Max.	
t_{PLH} t_{PHL}	Propagation Delay xAx to xBx, xBx to xAx	—	5.7	1.5	4.8	ns
t_{PZH} t_{PZL}	Output Enable Time \overline{xOE} to xAx or xBx	—	7.9	1.5	6.3	ns
t_{PHZ} t_{PLZ}	Output Disable Time \overline{xOE} to xAx or xBx	—	8.3	2.2	7.4	ns
$t_{SK(0)}$	Output Skew ⁽²⁾	—	—	—	500	ps

NOTES:

1. See TEST CIRCUITS AND WAVEFORMS. $T_A = -40^\circ C$ to $+85^\circ C$.
2. Skew between any two outputs of the same package and switching in the same direction.

TEST CIRCUITS AND WAVEFORMS

TEST CONDITIONS

Symbol	V _{CC} ⁽¹⁾ =3.3V±0.3V	V _{CC} ⁽¹⁾ =2.7V	V _{CC} ⁽²⁾ =2.5V±0.2V	Unit
V _{LOAD}	6	6	2 x V _{CC}	V
V _{IH}	2.7	2.7	V _{CC}	V
V _T	1.5	1.5	V _{CC} / 2	V
V _{LZ}	300	300	150	mV
V _{HZ}	300	300	150	mV
C _L	50	50	30	pF

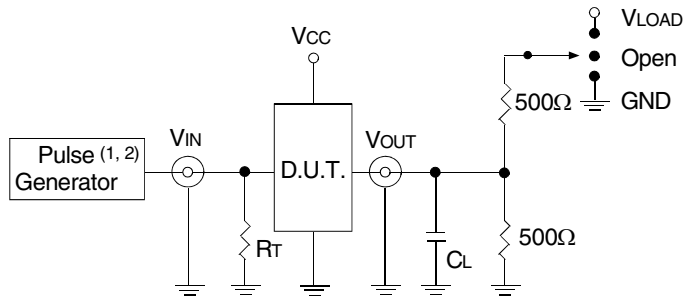

Test Circuit for All Outputs

DEFINITIONS:

C_L = Load capacitance: includes jig and probe capacitance.
R_T = Termination resistance: should be equal to Z_{OUT} of the Pulse Generator.

NOTES:

1. Pulse Generator for All Pulses: Rate ≤ 10MHz; t_r ≤ 2.5ns; t_r ≤ 2.5ns.
2. Pulse Generator for All Pulses: Rate ≤ 10MHz; t_r ≤ 2ns; t_r ≤ 2ns.

SWITCH POSITION

Test	Switch
Open Drain Disable Low Enable Low	V _{LOAD}
Disable High Enable High	GND
All Other Tests	Open

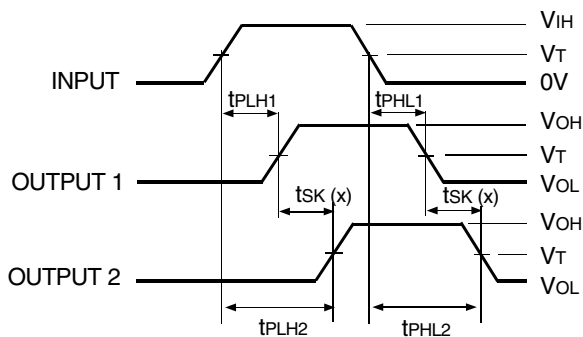

$$tsk(x) = |t_{PLH2} - t_{PLH1}| \text{ or } |t_{PHL2} - t_{PHL1}|$$

Output Skew - tsk(x)

NOTES:

1. For tsk(o) OUTPUT1 and OUTPUT2 are any two outputs.
2. For tsk(b) OUTPUT1 and OUTPUT2 are in the same bank.

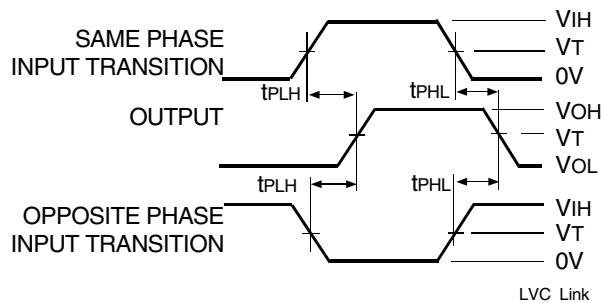

Propagation Delay

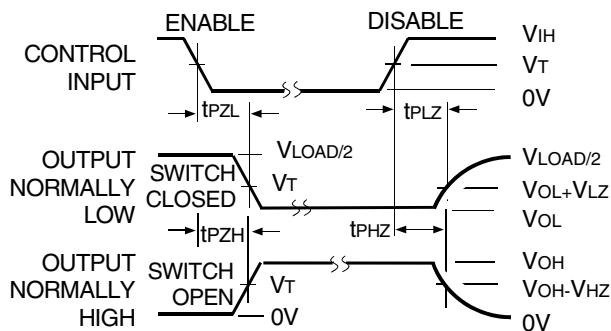

Enable and Disable Times

NOTE:

1. Diagram shown for input Control Enable-LOW and input Control Disable-HIGH.

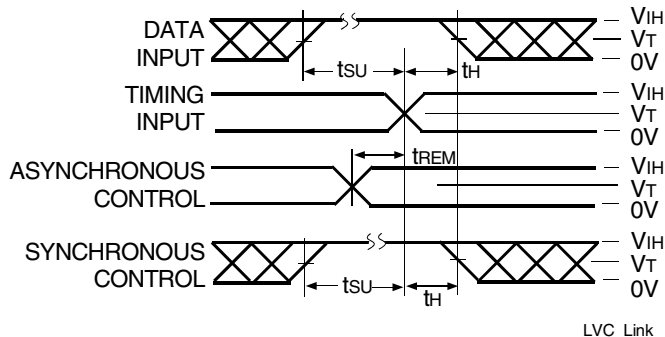

Set-up, Hold, and Release Times

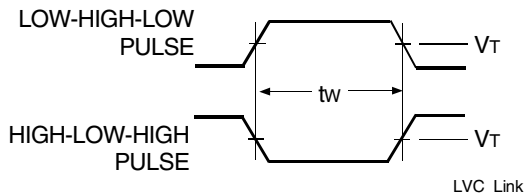

Pulse Width

ORDERING INFORMATION

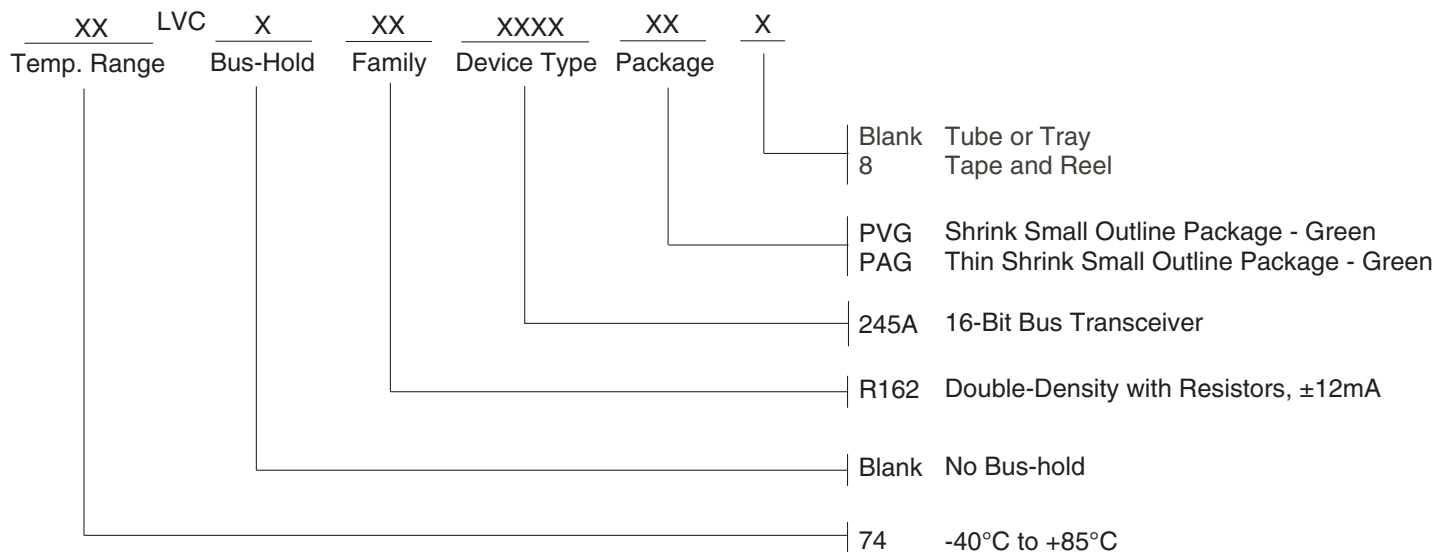

DATASHEET DOCUMENT HISTORY

07/28/2015 Pg. 6 Updated the ordering information by removing non RoHS parts and adding Tape and Reel information.



CORPORATE HEADQUARTERS
 6024 Silver Creek Valley Road
 San Jose, CA 95138

for SALES:
 800-345-7015 or 408-284-8200
 fax: 408-284-2775
 www.idt.com

for Tech Support:
 logichelp@idt.com