



Chipsmall Limited consists of a professional team with an average of over 10 year of expertise in the distribution of electronic components. Based in Hongkong, we have already established firm and mutual-benefit business relationships with customers from,Europe,America and south Asia,supplying obsolete and hard-to-find components to meet their specific needs.

With the principle of “Quality Parts,Customers Priority,Honest Operation,and Considerate Service”,our business mainly focus on the distribution of electronic components. Line cards we deal with include Microchip,ALPS,ROHM,Xilinx,Pulse,ON,Everlight and Freescale. Main products comprise IC,Modules,Potentiometer,IC Socket,Relay,Connector.Our parts cover such applications as commercial,industrial, and automotives areas.

We are looking forward to setting up business relationship with you and hope to provide you with the best service and solution. Let us make a better world for our industry!



Contact us

Tel: +86-755-8981 8866 Fax: +86-755-8427 6832

Email & Skype: info@chipsmall.com Web: www.chipsmall.com

Address: A1208, Overseas Decoration Building, #122 Zhenhua RD., Futian, Shenzhen, China



SINGLE BUS BUFFER (3-STATE)

- 5V TOLERANT INPUTS
- HIGH SPEED: $t_{PD} = 4.7\text{ns}$ (MAX.) at $V_{CC} = 3\text{V}$
- LOW POWER DISSIPATION:
 $I_{CC} = 1\mu\text{A}$ (MAX.) at $T_A = 25^\circ\text{C}$
- POWER DOWN PROTECTION ON INPUTS AND OUTPUTS
- SYMMETRICAL OUTPUT IMPEDANCE:
 $|I_{OH}| = I_{OL} = 24\text{mA}$ (MIN) at $V_{CC} = 3\text{V}$
- BALANCED PROPAGATION DELAYS:
 $t_{PLH} \approx t_{PHL}$
- WIDE OPERATING VOLTAGE RANGE:
 $V_{CC}(\text{OPR}) = 1.65\text{V}$ to 5.5V
(1.2V Data Retention)
- LATCH-UP PERFORMANCE EXCEED 300mA
- RoHS FLIP-CHIP AND SOT PACKAGES

DESCRIPTION

The 74LX1G125 is a low voltage CMOS SINGLE BUS BUFFER fabricated with sub-micron silicon gate and double-layer metal wiring C²MOS technology.

3-STATE control input \overline{G} has to be set HIGH to place the output into the high impedance state. Power down protection is provided on all inputs and 0 to 7V can be accepted on inputs with no regard to the supply voltage. This device can be used to interface 5V to 3V or lower power supply systems. The sub-micron CMOS technology used

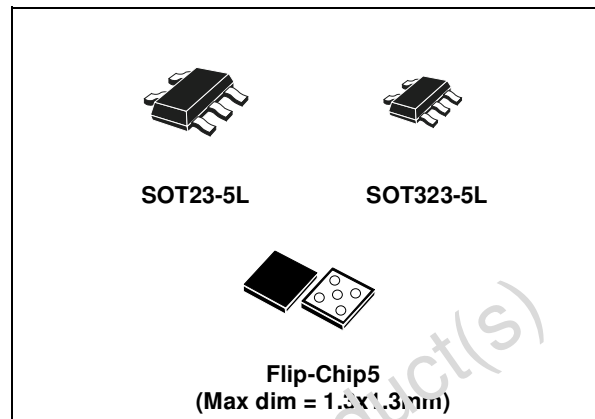

ORDER CODES

PACKAGE	T & R
SOT23-5L	74LX1G125STR
SOT323-5L	74LX1G125CTR
Flip-Chip5	74LX1G125BJR

allow ultra low power consumption and guarantee optimized operations between 2.8V and 1.8V system, as Smart Phone, Digital Still Camera, PDA, Notebook, or each other battery powered equipment.

All inputs and outputs are equipped with protection circuits against ESD discharge.

PIN CONNECTION AND IEC LOGIC SYMBOLS (top view for SOT, top through view for Flip-Chip)

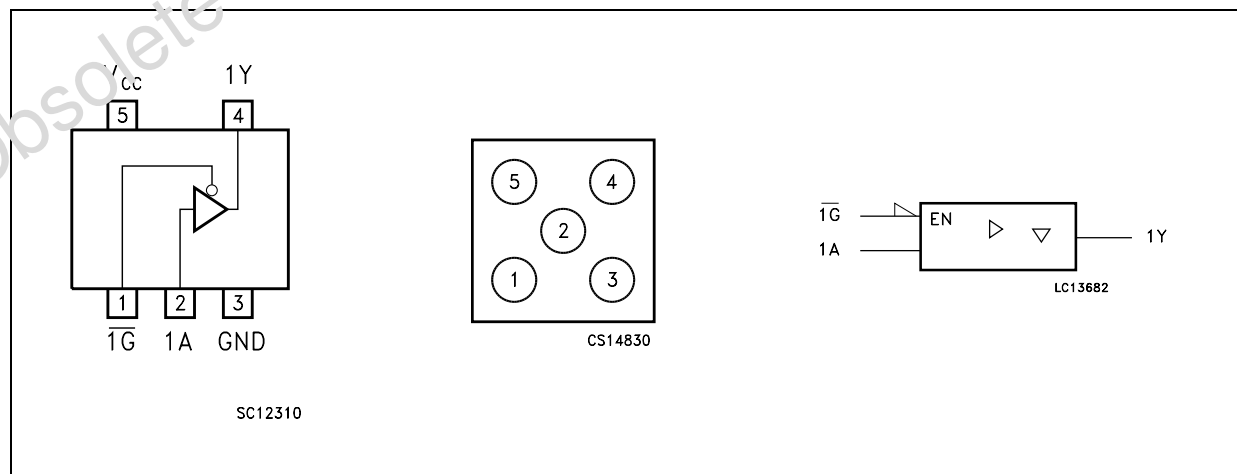

74LX1G125

INPUT EQUIVALENT CIRCUIT

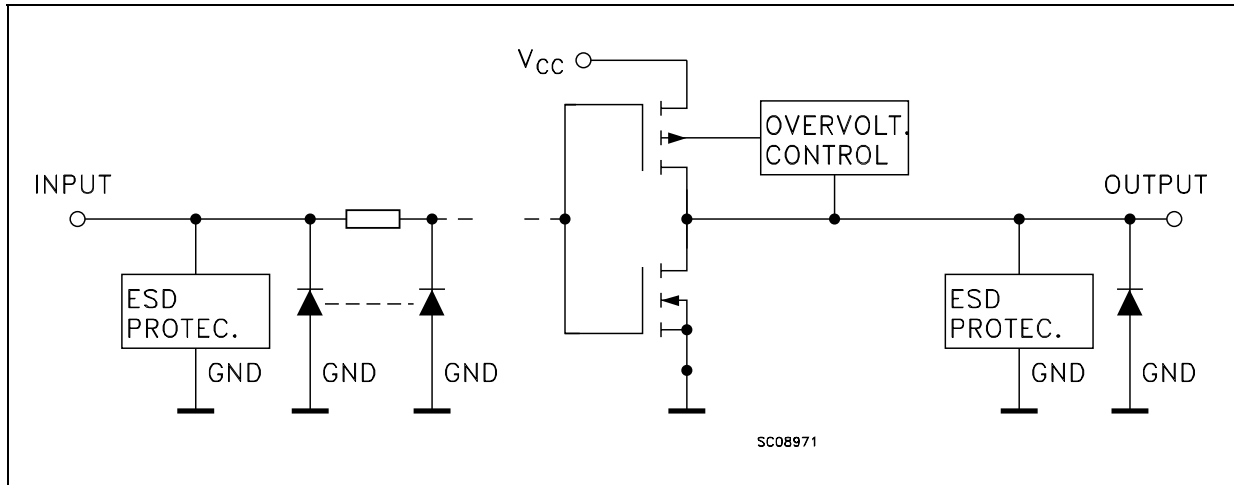

PIN DESCRIPTION

SOT23-5L PIN N°	Flip-Chip PIN N°	SYMBOL	NAME AND FUNCTION
1	5	1G	Output Enable Input
2	1	1A	Data Input
4	3	1Y	Data Output
3	2	GND	Ground (0V)
5	4	V _{CC}	Positive Supply Voltage

TRUTH TABLE

A	\overline{G}	Y
X	H	Z
L	L	L
H	L	H

X : Don't Care
Z : High Impedance

ABSOLUTE MAXIMUM RATINGS

Symbol	Parameter	Value	Unit
V _{CC}	Supply Voltage	-0.5 to +7.0	V
V _I	DC Input Voltage	-0.5 to +7.0	V
V _O	DC Output Voltage (V _{CC} = 0V)	-0.5 to +7.0	V
V _O	DC Output Voltage (High or Low State) (note 1)	-0.5 to V _{CC} + 0.5	V
I _{IK}	DC Input Diode Current	- 50	mA
I _{OK}	DC Output Diode Current (note 2)	- 50	mA
I _O	DC Output Current	± 50	mA
I _{CC} or I _{GND}	DC V _{CC} or Ground Current per Supply Pin	± 50	mA
T _{stg}	Storage Temperature	-65 to +150	°C
T _L	Lead Temperature (10 sec)	260	°C

Absolute Maximum Ratings are those values beyond which damage to the device may occur. Functional operation under these conditions is not implied

- 1) I_O absolute maximum rating must be observed
2) V_O < GND

RECOMMENDED OPERATING CONDITIONS

Symbol	Parameter	Value	Unit
V_{CC}	Supply Voltage (note 1)	1.65 to 5.5	V
V_I	Input Voltage	0 to 5.5	V
V_O	Output Voltage ($V_{CC} = 0V$)	0 to 5.5	V
V_O	Output Voltage (High or Low State)	0 to V_{CC}	V
I_{OH}, I_{OL}	High or Low Level Output Current ($V_{CC} = 4.5$ to $5.5V$)	± 32	mA
I_{OH}, I_{OL}	High or Low Level Output Current ($V_{CC} = 3.0$ to $3.6V$)	± 24	mA
I_{OH}, I_{OL}	High or Low Level Output Current ($V_{CC} = 2.7$ to $3.0V$)	± 12	mA
I_{OH}, I_{OL}	High or Low Level Output Current ($V_{CC} = 2.3$ to $2.7V$)	± 8	mA
I_{OH}, I_{OL}	High or Low Level Output Current ($V_{CC} = 1.65$ to $2.3V$)	± 4	mA
T_{op}	Operating Temperature	-55 to 125	$^{\circ}C$
dt/dv	Input Rise and Fall Time ($V_{CC} = 3.0$ to $5.5V$) (note 2)	0 to 10	ns/V
	($V_{CC} = 1.65$ to $2.7V$) (note 2)	0 to 20	

1) Truth Table guaranteed: 1.2V to 5.5V

2) V_{IN} from 0.8V to 2V at $V_{CC} = 3.0V$

DC SPECIFICATIONS

Symbol	Parameter	Test Condition		Value				Unit
		V _{CC} (V)		-40 to 85 °C		-55 to 125 °C		
				Min.	Max.	Min.	Max.	
V _{IH}	High Level Input Voltage	1.65 to 1.95		0.75V _{CC}		0.75V _{CC}		V
		2.3 to 2.7		0.7V _{CC}		0.7V _{CC}		
		3.0 to 5.5		0.7V _{CC}		0.7V _{CC}		
V _{IL}	Low Level Input Voltage	1.65 to 1.95			0.25V _{CC}		0.25V _{CC}	V
		2.3 to 2.7			0.3V _{CC}		0.3V _{CC}	
		3.0 to 5.5			0.3V _{CC}		0.3V _{CC}	
V _{OH}	High Level Output Voltage	1.65 to 4.5	I _O =-100 μA	V _{CC} -0.1		V _{CC} -0.1		V
		1.65	I _O =-4 mA	1.2		1.2		
		2.3	I _O =-8 mA	1.9		1.9		
		3.0	I _O =-16 mA	2.4		2.4		
			I _O =-24 mA	2.2		2.2		
4.5	I _O =-32 mA	3.8		3.8				
V _{OL}	Low Level Output Voltage	1.65 to 4.5	I _O =100 μA		0.1		0.1	V
		1.65	I _O =4 mA		0.45		0.45	
		2.3	I _O =8 mA		0.3		0.3	
		3.0	I _O =16 mA		0.4		0.4	
			I _O =24 mA		0.55		0.55	
4.5	I _O =32 mA		0.55		0.55			
I _{OZ}	High Impedance Output Leakage Current	3.6	V _I = 0 to 5.5V		± 10		± 10	μA
I _I	Input Leakage Current	1.65 to 5.5	V _I = 0 to 5.5V		± 5		± 5	μA
I _{off}	Power Off Leakage Current	0	V _I or V _O = 5.5V		10		10	μA
I _{CC}	Quiescent Supply Current	1.65 to 5.5	V _I = V _{CC} or GND		10		10	μA
		3.6	V _I or V _O = 3.6 to 5.5V		± 10		± 10	

AC ELECTRICAL CHARACTERISTICS

Symbol	Parameter	Test Condition				Value				Unit
		V _{CC} (V)	C _L (pF)	R _L (Ω)	t _s = t _r (ns)	-40 to 85 °C		-55 to 125 °C		
						Min.	Max.	Min.	Max.	
t _{PLH} t _{PHL}	Propagation Delay Time	1.65 to 1.95	15	1MΩ	3.0	2	10.0	2	11.0	ns
		2.3 to 2.7				2	7.0	2	8.0	
		3.0 to 3.6				1	4.7	1	5.7	
		4.5 to 5.5				1	4.1	1	5.1	
		1.65 to 1.95	30	1000	2.0	2	11.0	2	12.0	
		2.3 to 2.7	30	500	2.0	2	7.5	2	8.5	
		2.7	50	500	2.5	1	5.5	1	6.5	
		3.0 to 3.6	50	500	2.5	1	5.2	1	6.2	
		4.5 to 5.5	50	500	2.5	1	4.2	1	5.2	
t _{PLZ} t _{PHZ}	Output Disable Time	1.65 to 1.95	15	1MΩ	3.0	2	12.0	2	12.0	ns
		2.3 to 2.7				2	7.0	2	7.0	
		3.0 to 3.6				1	5.5	1	5.5	
		4.5 to 5.5				1	5.0	1	5.0	
		1.65 to 1.95	30	1000	2.0	2	9.2	2	9.2	
		2.3 to 2.7	30	500	2.0	2	5.5	2	5.5	
		2.7	50	500	2.5	1	5.2	1	5.2	
		3.0 to 3.6	50	500	2.5	1	5.0	1	5.0	
		4.5 to 5.5	50	500	2.5	1	4.2	1	4.2	
t _{PZL} t _{PZH}	Output Enable Time	1.65 to 1.95	15	1MΩ	3.0	2	12.0	2	12.0	ns
		2.3 to 2.7				2	7.0	2	7.0	
		3.0 to 3.6				1	6.0	1	6.0	
		4.5 to 5.5				1	5.5	1	5.5	
		1.65 to 1.95	30	1000	2.0	2	9.4	2	9.4	
		2.3 to 2.7	30	500	2.0	2	6.6	2	6.6	
		2.7	50	500	2.5	1	5.6	1	5.6	
		3.0 to 3.6	50	500	2.5	1	5.3	1	5.3	
		4.5 to 5.5	50	500	2.5	1	5.0	1	5.0	

CAPACITIVE CHARACTERISTICS

Symbol	Parameter	Test Condition		Value			Unit
		V _{CC} (V)		T _A = 25 °C			
				Min.	Typ.	Max.	
C _{IN}	Input Capacitance		V _{IN} = 0 or V _{CC}		4		pF
C _{OUT}	Output Capacitance		V _{IN} = 0 or V _{CC}		5	10	pF
C _{PD}	Power Dissipation Capacitance (note 1)	1.8	f _{IN} = 10MHz		18		pF
		2.5			18		
		3.3			21		

1) C_{PD} is defined as the value of the IC's internal equivalent capacitance which is calculated from the operating current consumption without load. (Refer to Test Circuit). Average operating current can be obtained by the following equation. I_{CC(oper)} = C_{PD} × V_{CC} × f_{IN} + I_{CC}

74LX1G125

TEST CIRCUIT

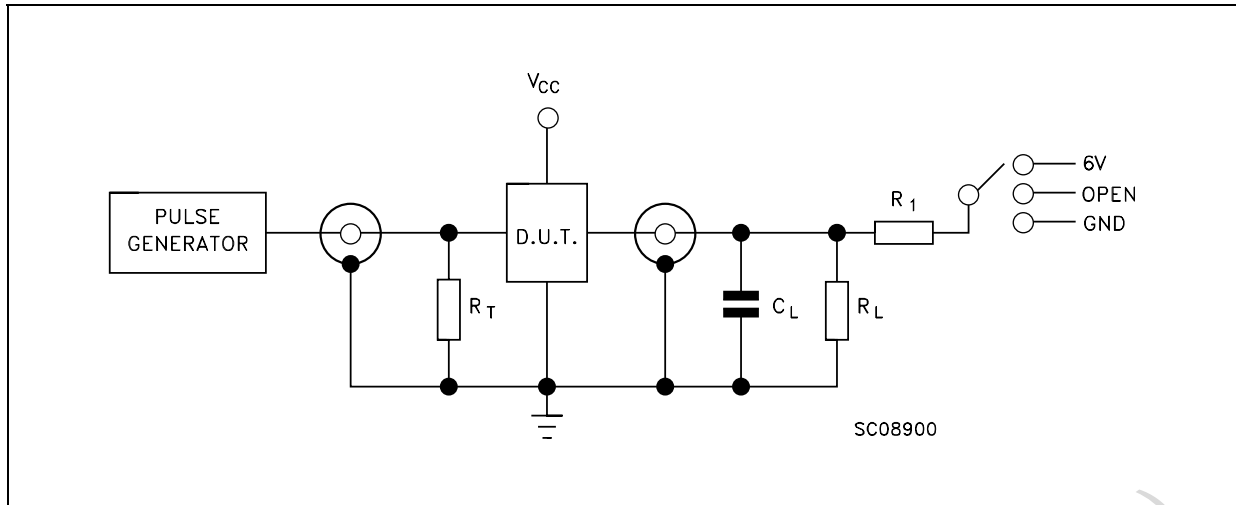

$R_T = Z_{OUT}$ of pulse generator (typically 50 Ω)

TEST CIRCUIT AND WAVEFORM SYMBOL VALUE

Symbol	V_{CC}		
	1.65 to 1.95V	2.3 to 2.7V	2.7 to 5.5V
C_L	15pF/30pF	15pF/30pF	15pF/50pF
$R_L=R_1$	1M Ω /1000 Ω	1M Ω /500 Ω	1M Ω /500 Ω
V_{IH}	V_{CC}	V_{CC}	V_{CC}
V_M	$V_{CC}/2$	$V_{CC}/2$	$V_{CC}/2$
$t_r = t_f$	<2.0ns	<2.0ns	<2.5ns

WAVEFORM 1: PROPAGATION DELAYS (f=1MHz; 50% duty cycle)

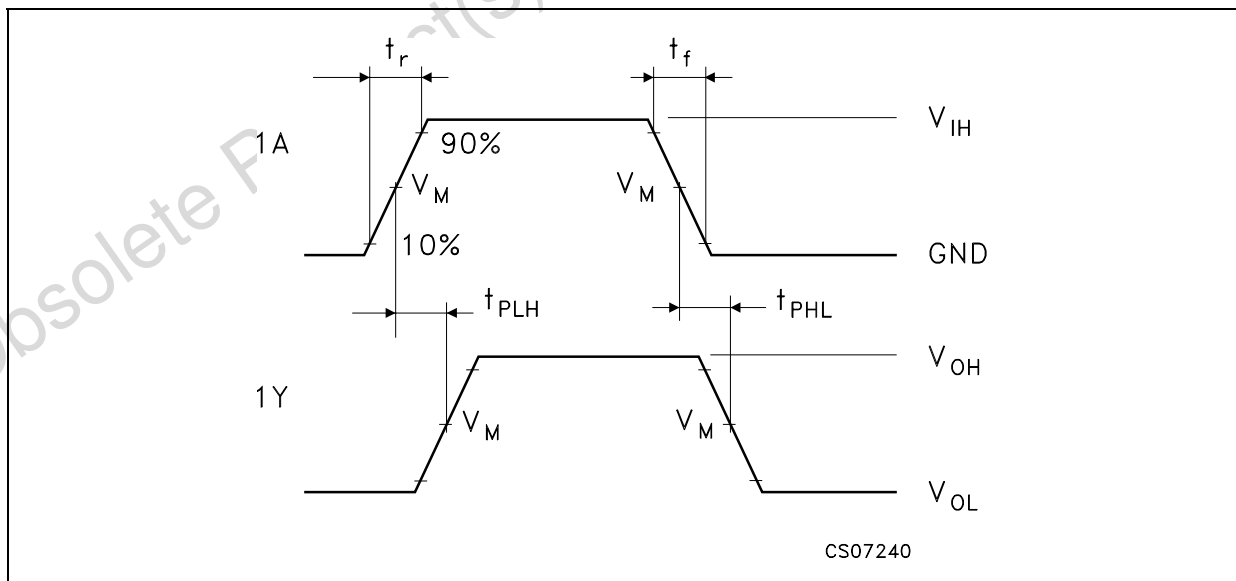

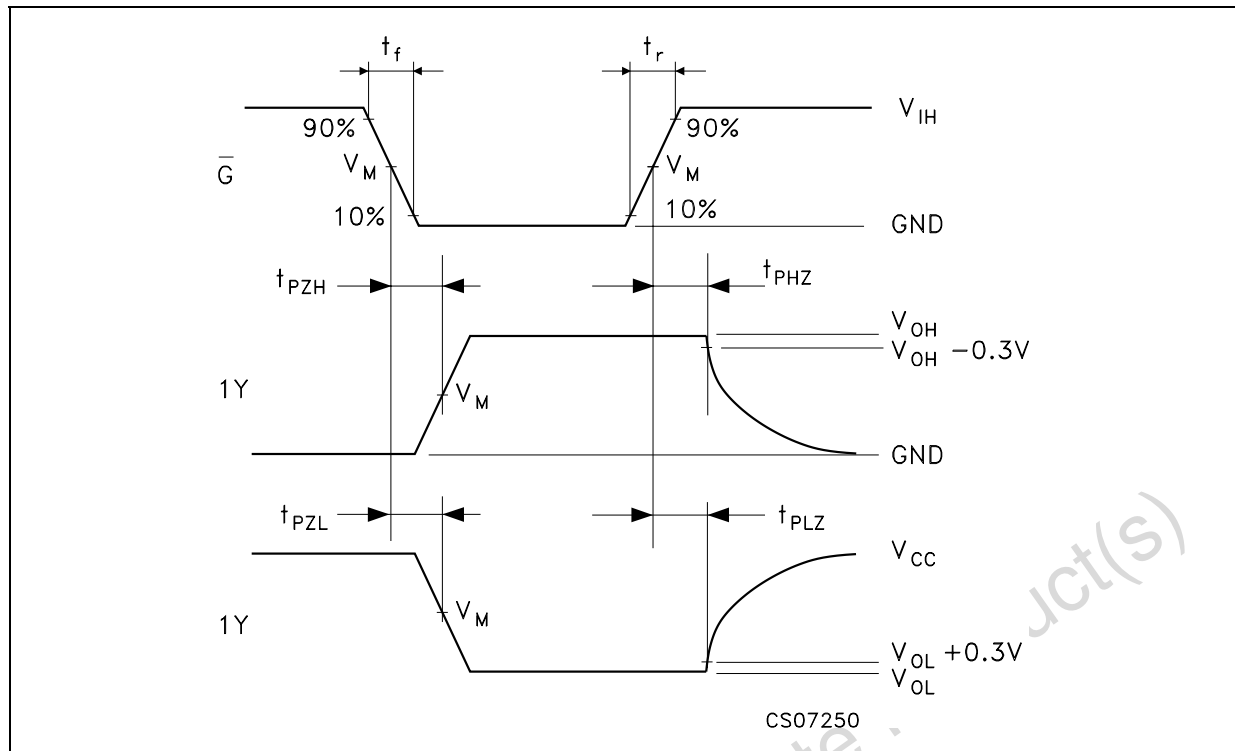
WAVEFORM 2: OUTPUT ENABLE AND DISABLE TIME ($f=1\text{MHz}$; 50% duty cycle)

SOT23-5L MECHANICAL DATA

DIM.	mm.			mils		
	MIN.	TYP	MAX.	MIN.	TYP.	MAX.
A	0.90		1.45	35.4		57.1
A1	0.00		0.10	0.0		3.9
A2	0.90		1.30	35.4		51.2
b	0.35		0.50	13.7		19.7
C	0.09		0.20	3.5		7.8
D	2.80		3.00	110.2		118.1
E	1.50		1.75	59.0		68.8
e		0.95			37.4	
H	2.60		3.00	102.3		118.1
L	0.10		0.60	3.9		23.6

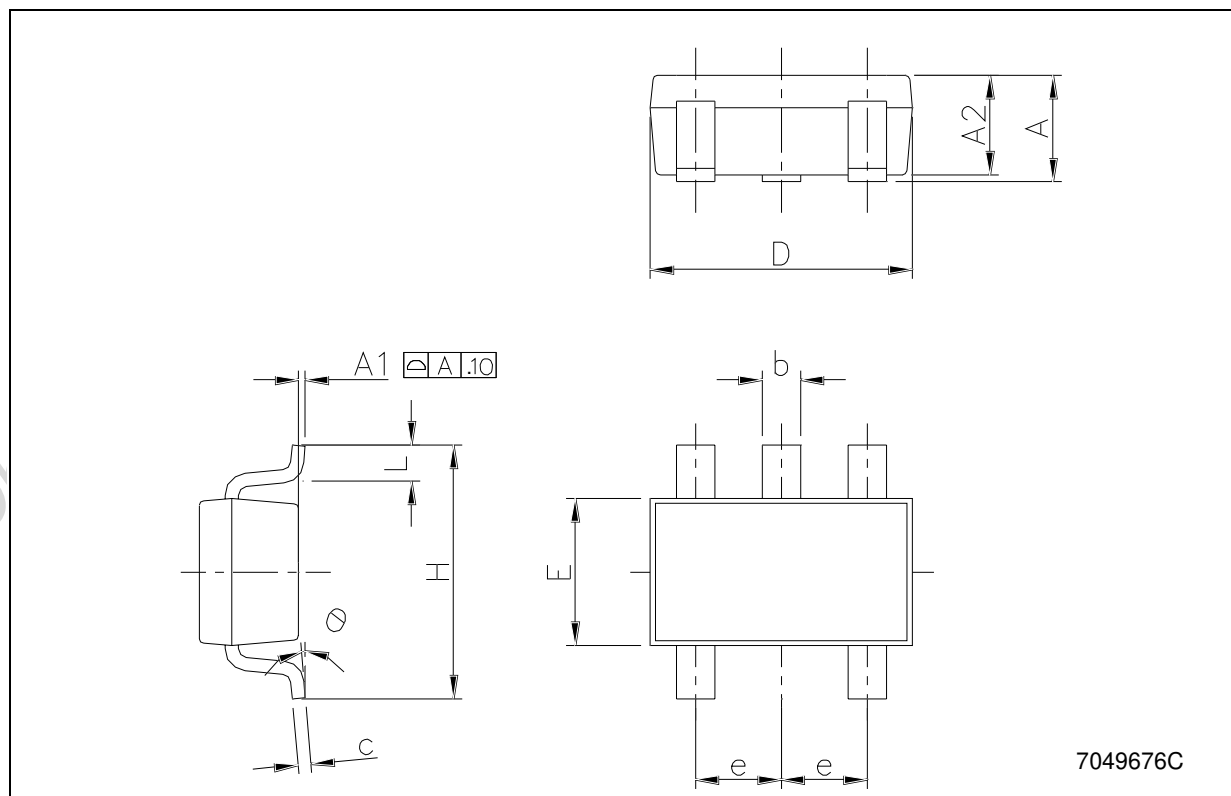

SOT323-5L MECHANICAL DATA

DIM.	mm.			mils		
	MIN.	TYP	MAX.	MIN.	TYP.	MAX.
A	0.80		1.10	31.5		43.3
A1	0.00		0.10	0.0		3.9
A2	0.80		1.00	31.5		39.4
b	0.15		0.30	5.9		11.8
C	0.10		0.18	3.9		7.1
D	1.80		2.20	70.9		86.6
E	1.80		2.40	70.9		94.5
E1	1.15		1.35	45.3		53.1
e		0.65			25.6	
e1		1.3			51.2	
L	0.10		0.30	3.9		11.8

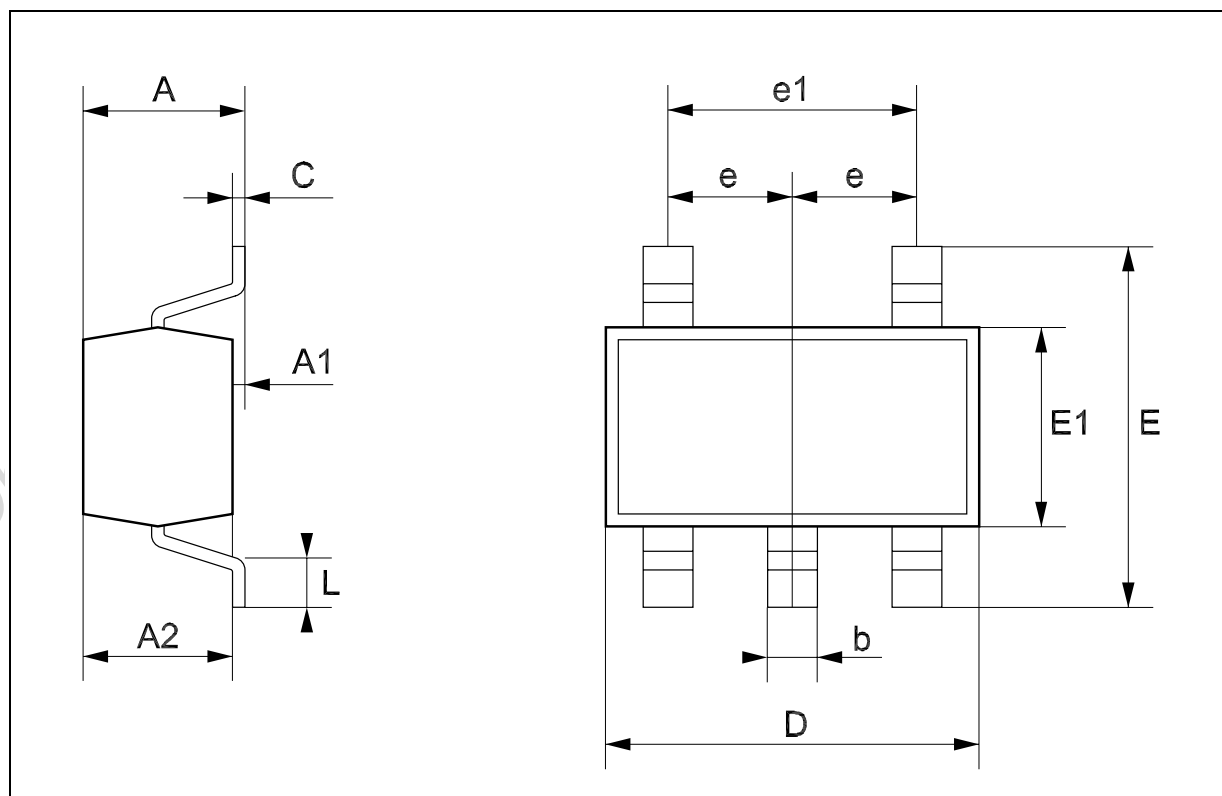

Flip-Chip5 MECHANICAL DATA

DIM.	mm.			mils		
	MIN.	TYP	MAX.	MIN.	TYP.	MAX.
A		0.6			23.622	
A1		0.25			9.843	
A2		0.35			13.779	
b	0.265	0.315	0.365	10.433	12.402	14.370
D	Value Depending On The Die Size					
E	Value Depending On The Die Size					
e		0.7			27.559	

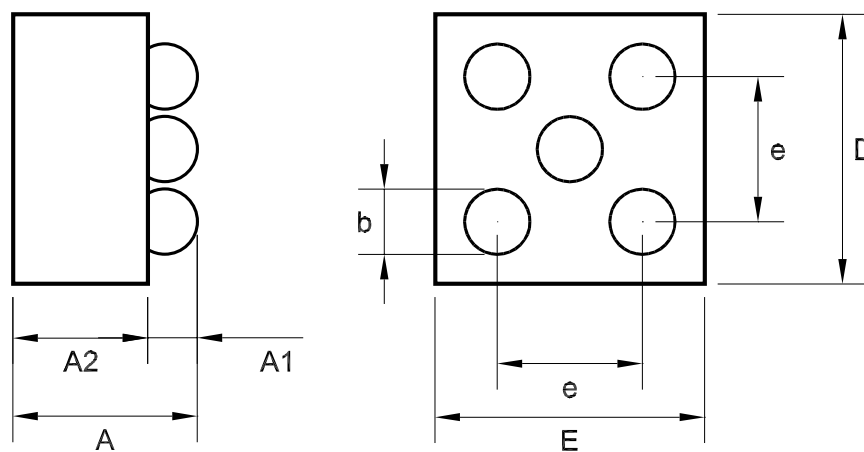

Tape & Reel SOT23-xL MECHANICAL DATA

DIM.	mm.			inch		
	MIN.	TYP	MAX.	MIN.	TYP.	MAX.
A			180			7.086
C	12.8	13.0	13.2	0.504	0.512	0.519
D	20.2			0.795		
N	60			2.362		
T			14.4			0.567
Ao	3.13	3.23	3.33	0.123	0.127	0.131
Bo	3.07	3.17	3.27	0.120	0.124	0.128
Ko	1.27	1.37	1.47	0.050	0.054	0.058
Po	3.9	4.0	4.1	0.153	0.157	0.161
P	3.9	4.0	4.1	0.153	0.157	0.161

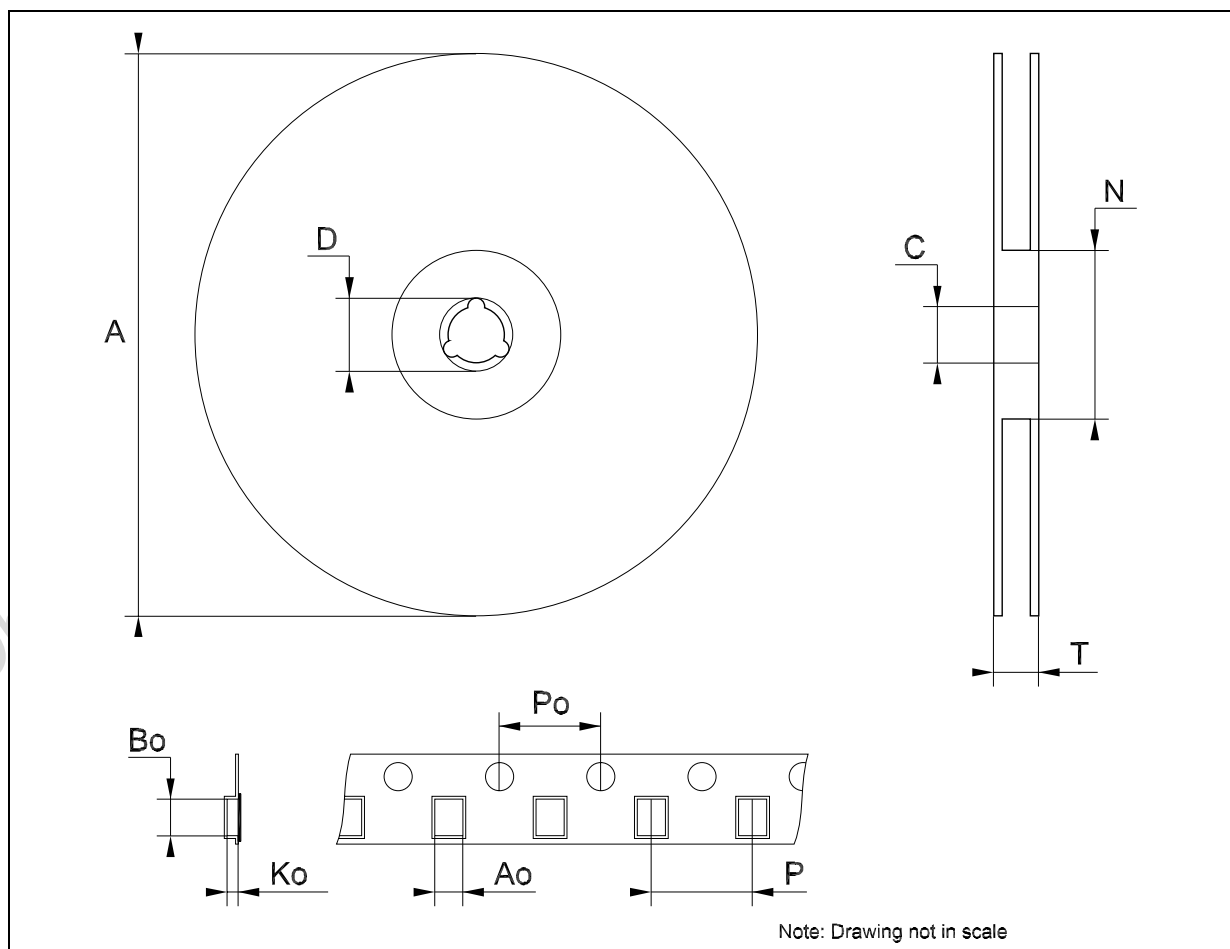

Tape & Reel SOT323-xL MECHANICAL DATA

DIM.	mm.			inch		
	MIN.	TYP	MAX.	MIN.	TYP.	MAX.
A	175	180	185	6.889	7.086	7.283
C	12.8	13	13.2	0.504	0.512	0.519
D	20.2			0.795		
N	59.5	60	60.5		2.362	
T			14.4			0.567
Ao		2.25			0.088	
Bo		2.7			0.106	
Ko		1.2			0.047	
Po	3.9	4	4.1	0.153	0.157	0.161
P	3.8	4	4.2	0.149	0.157	0.165

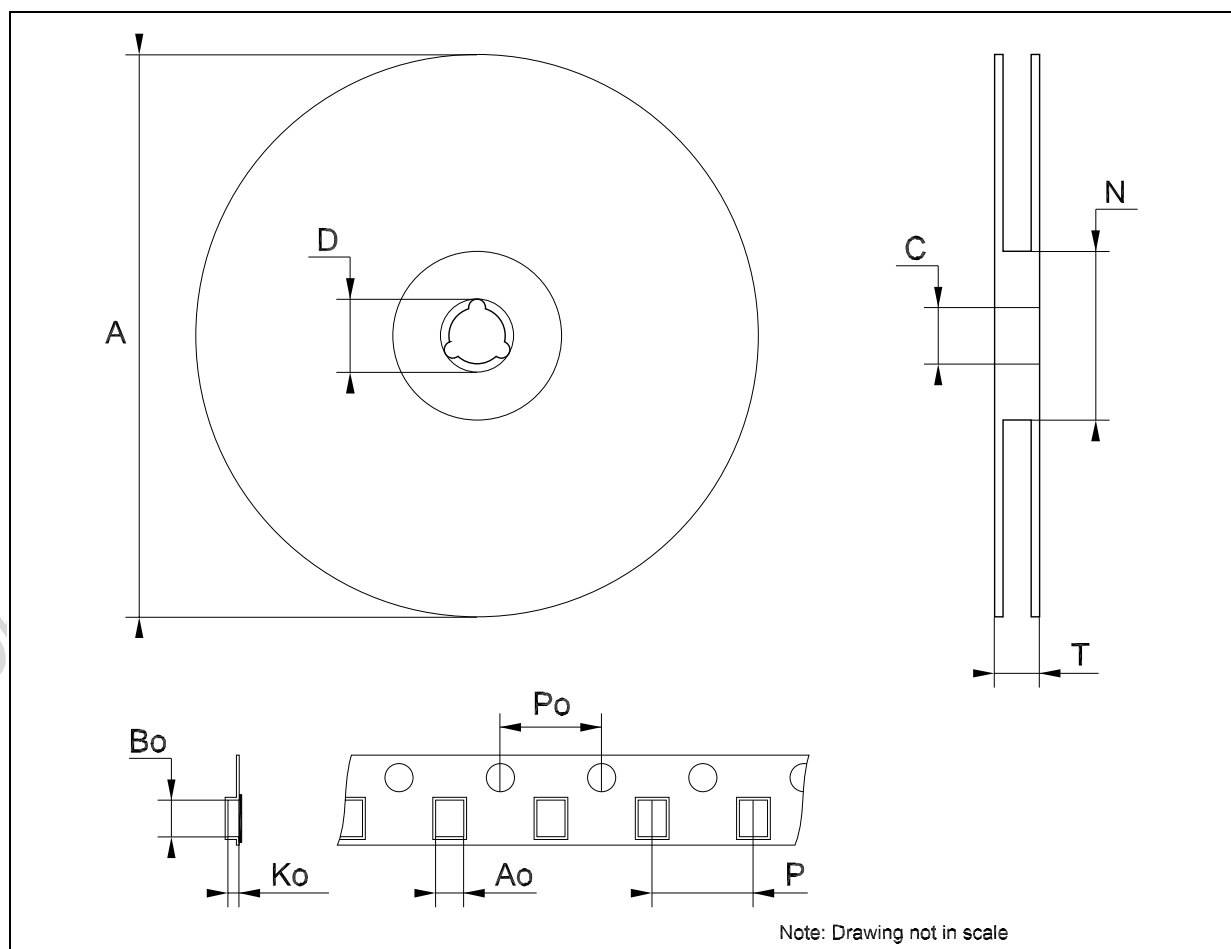

Information furnished is believed to be accurate and reliable. However, STMicroelectronics assumes no responsibility for the consequences of use of such information nor for any infringement of patents or other rights of third parties which may result from its use. No license is granted by implication or otherwise under any patent or patent rights of STMicroelectronics. Specifications mentioned in this publication are subject to change without notice. This publication supersedes and replaces all information previously supplied. STMicroelectronics products are not authorized for use as critical components in life support devices or systems without express written approval of STMicroelectronics.

The ST logo is a registered trademark of STMicroelectronics
All other names are the property of their respective owners

© 2004 STMicroelectronics - All Rights Reserved
STMicroelectronics GROUP OF COMPANIES

Australia - Belgium - Brazil - Canada - China - Czech Republic - Finland - France - Germany - Hong Kong - India - Israel - Italy - Japan -
Malaysia - Malta - Morocco - Singapore - Spain - Sweden - Switzerland - United Kingdom - United States.

<http://www.st.com>