



Chipsmall Limited consists of a professional team with an average of over 10 year of expertise in the distribution of electronic components. Based in Hongkong, we have already established firm and mutual-benefit business relationships with customers from,Europe,America and south Asia,supplying obsolete and hard-to-find components to meet their specific needs.

With the principle of "Quality Parts,Customers Priority,Honest Operation,and Considerate Service",our business mainly focus on the distribution of electronic components. Line cards we deal with include Microchip,ALPS,ROHM,Xilinx,Pulse,ON,Everlight and Freescale. Main products comprise IC,Modules,Potentiometer,IC Socket,Relay,Connector.Our parts cover such applications as commercial,industrial, and automotives areas.

We are looking forward to setting up business relationship with you and hope to provide you with the best service and solution. Let us make a better world for our industry!



## Contact us

Tel: +86-755-8981 8866 Fax: +86-755-8427 6832

Email & Skype: info@chipsmall.com Web: www.chipsmall.com

Address: A1208, Overseas Decoration Building, #122 Zhenhua RD., Futian, Shenzhen, China



# 74LVT273

## 3.3 V octal D-type flip-flop

Rev. 03 — 10 September 2008

Product data sheet

## 1. General description

---

The 74LVT273 is a high-performance BiCMOS product designed for  $V_{CC}$  operation at 3.3 V.

This device has eight edge-triggered D-type flip-flops with individual D inputs and Q outputs. The common buffered Clock (CP) and Master Reset ( $\overline{MR}$ ) inputs load and reset (clear) all flip-flops simultaneously.

The register is fully edge-triggered. The state of each D input, one setup time before the LOW-to-HIGH clock transition, is transferred to the corresponding flip-flop's Q output.

All outputs will be forced LOW independent of the clock or data inputs by a LOW voltage level on the  $\overline{MR}$  input. The device is useful for applications where only the true output is required and the CP and  $\overline{MR}$  are common elements.

## 2. Features

---

- Eight edge-triggered D-type flip-flops
- Buffered common clock and asynchronous master reset
- Input and output interface capability to systems at 5 V supply
- TTL input and output switching levels
- Input and output interface capability to systems at 5 V supply
- Output capability: +64 mA/−32 mA
- Latch-up protection
  - ◆ JESD78 Class II exceeds 500 mA
- ESD protection:
  - ◆ HBM JESD22-A114E exceeds 2000 V
  - ◆ MM JESD22-A115-A exceeds 200 V
- Bus-hold data inputs eliminate the need for external pull-up resistors for unused inputs
- Live insertion/extraction permitted
- Power-up reset
- No bus current loading when output is tied to 5 V bus

### 3. Ordering information

Table 1. Ordering information

Type number	Package			Version
	Temperature range	Name	Description	
74LVT273D	-40 °C to +125 °C	SO20	plastic small outline package; 20 leads; body width 7.5 mm	SOT163-1
74LVT273DB	-40 °C to +125 °C	SSOP20	plastic shrink small outline package; 20 leads; body width 5.3 mm	SOT339-1
74LVT273PW	-40 °C to +125 °C	TSSOP20	plastic thin shrink small outline package; 20 leads; body width 4.4 mm	SOT360-1
74LVT273BQ	-40 °C to +125 °C	DHVQFN20	plastic dual in-line compatible thermal enhanced very thin quad flat package; no leads; 20 terminals; body 2.5 × 4.5 × 0.85 mm	SOT764-1

### 4. Functional diagram

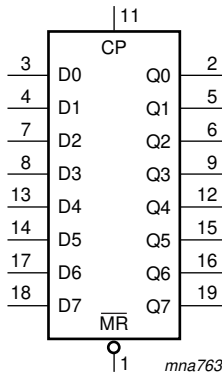

Fig 1. Logic symbol

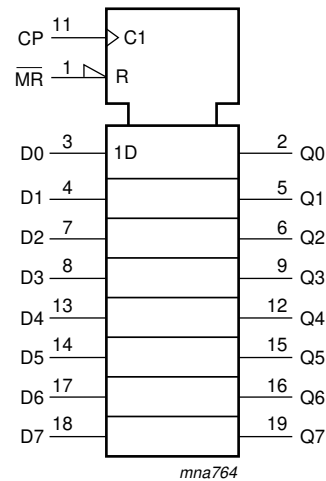

Fig 2. IEC logic symbol

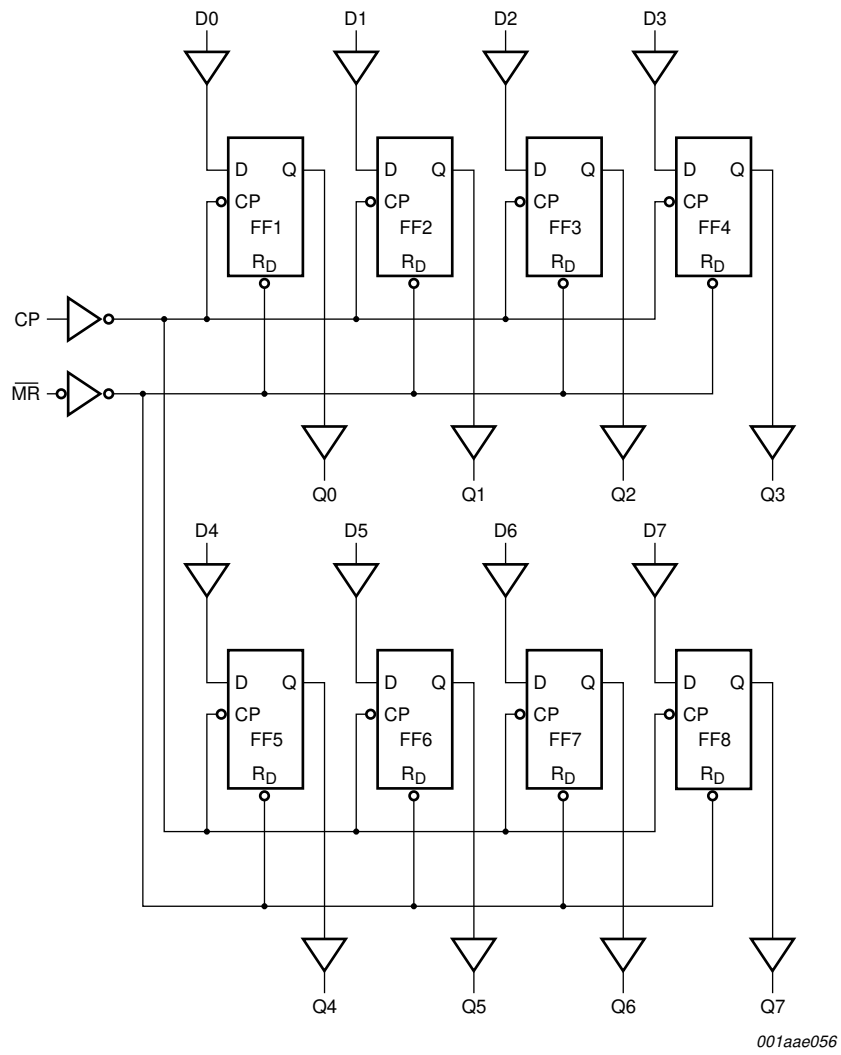
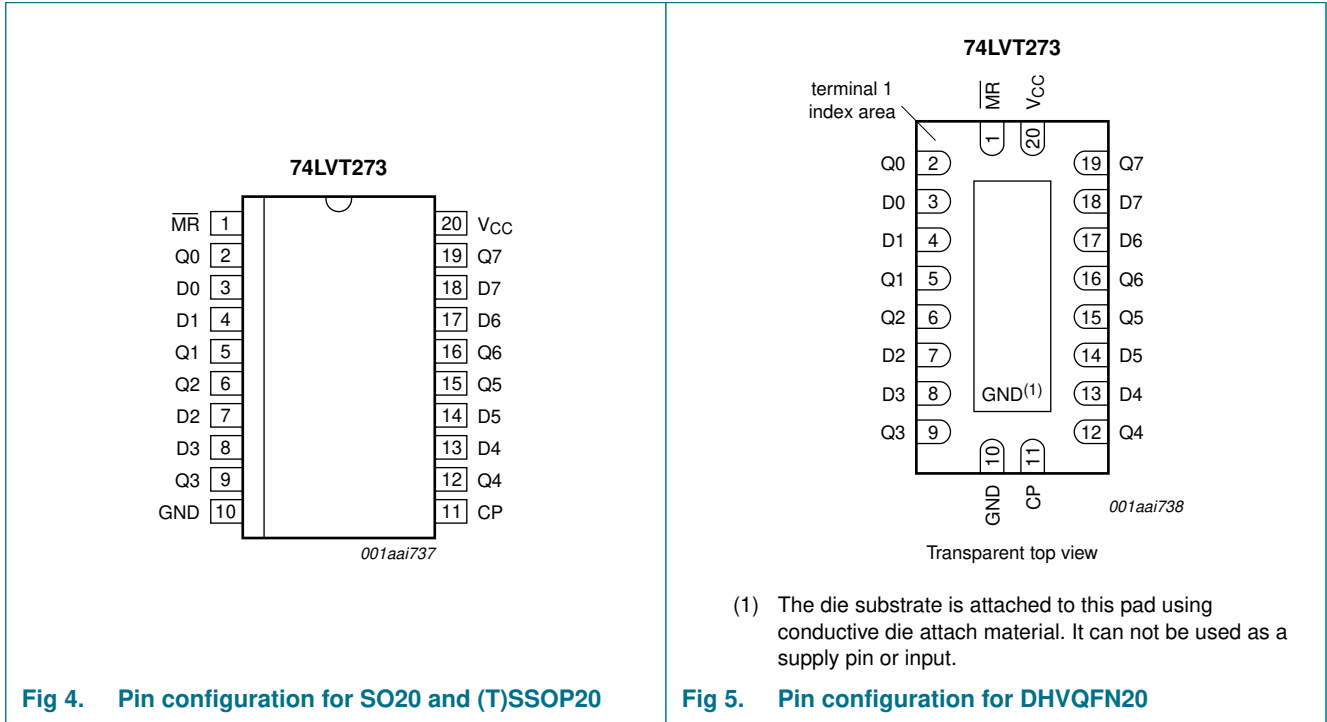

Fig 3. Logic diagram

5. Pinning information

5.1 Pinning



5.2 Pin description

Table 2. Pin description

Symbol	Pin	Description
$\overline{MR}$	1	master reset input (active LOW)
Q0 to Q7	2, 5, 6, 9, 12, 15, 16, 19	data output
D0 to D7	3, 4, 7, 8, 13, 14, 17, 18	data input
GND	10	ground (0 V)
CP	11	clock pulse input (active on rising edge)
V <sub>CC</sub>	20	positive supply voltage

## 6. Functional description

**Table 3. Function selection**

Inputs			Outputs	Operating mode
MR	CP	Dn	Qn	
L	X	X	L	Reset (clear)
H	↑	h	H	Load 1
H	↑	l	L	Load 0
H	L	X	Q0	Retain state

- [1] H = HIGH voltage level; h = HIGH voltage level one set-up time prior to the prior to the LOW-to-HIGH clock transition;  
 L = LOW voltage level; l = LOW voltage level one set-up time prior to the prior to the LOW-to-HIGH clock transition;  
 X = Don't care; ↑ = LOW-to-HIGH clock transition; Q0 = output as it was.

## 7. Limiting values

**Table 4. Limiting values**

In accordance with the Absolute Maximum Rating System (IEC 60134). Voltages are referenced to GND (ground = 0 V).

Symbol	Parameter	Conditions	Min	Max	Unit
V <sub>CC</sub>	supply voltage		-0.5	+4.6	V
V <sub>I</sub>	input voltage		[1] -0.5	+7.0	V
V <sub>O</sub>	output voltage	Output in OFF or HIGH state	[1] -0.5	+7.0	V
I <sub>IK</sub>	input clamping current	V <sub>I</sub> < 0 V	-50	-	mA
I <sub>OK</sub>	output clamping current	V <sub>O</sub> < 0 V	-50	-	mA
I <sub>O</sub>	output current	output in LOW state	-	128	mA
		output in HIGH state	-64	-	mA
T <sub>stg</sub>	storage temperature		-65	+150	°C
T <sub>j</sub>	junction temperature		[2] -	150	°C
P <sub>tot</sub>	total power dissipation	T <sub>amb</sub> = -40 °C to +85 °C	[3]	500	mW

- [1] The input and output negative voltage ratings may be exceeded if the input and output clamp current ratings are observed.  
 [2] The performance capability of a high-performance integrated circuit in conjunction with its thermal environment can create junction temperatures which are detrimental to reliability.  
 [3] For SO20 packages: above 70 °C derate linearly with 8 mW/K.  
 For SSOP20 and TSSOP20 packages: above 60 °C derate linearly with 5.5 mW/K.  
 For DHVQFN20 packages: above 60 °C derate linearly with 4.5 mW/K.

## 8. Recommended operating conditions

**Table 5. Recommended operating conditions**

Symbol	Parameter	Conditions	Min	Typ	Max	Unit
V <sub>CC</sub>	supply voltage		2.7	-	3.6	V
V <sub>I</sub>	input voltage		0	-	5.5	V
I <sub>OH</sub>	HIGH-level output current		-32	-	-	mA

**Table 5. Recommended operating conditions ...continued**

Symbol	Parameter	Conditions	Min	Typ	Max	Unit
$I_{OL}$	LOW-level output current		-	-	64	mA
$T_{amb}$	ambient temperature	in free air	-40	-	+85	°C
$\Delta t/\Delta V$	input transition rise and fall rate; output enabled		-	-	10	ns/V

## 9. Static characteristics

**Table 6. Static characteristics**

At recommended operating conditions. Voltages are referenced to GND (ground = 0 V).

Symbol	Parameter	Conditions	-40 °C to +85 °C			Unit
			Min	Typ <sup>[1]</sup>	Max	
$V_{IK}$	input clamping voltage	$V_{CC} = 2.7V$ ; $I_{IK} = -18\text{ mA}$	-1.2	-0.9	-	V
$V_{IH}$	HIGH-level input voltage		2.0	-	-	V
$V_{IL}$	LOW-level input voltage		-	-	0.8	V
$V_{OH}$	HIGH-level output voltage	$V_{CC} = 2.7\text{ V to }3.6V$ ; $I_{OH} = -100\ \mu\text{A}$	$V_{CC} - 0.2$	$V_{CC} - 0.1$	-	V
		$V_{CC} = 2.7\text{ V}$ ; $I_{OH} = -8\text{ mA}$	2.4	2.5	-	V
		$V_{CC} = 3.0\text{ V}$ ; $I_{OH} = -32\text{ mA}$	2.0	2.2	-	V
$V_{OL}$	LOW-level output voltage	$V_{CC} = 2.7\text{ V}$ ; $I_{OL} = 100\ \mu\text{A}$		0.1	0.2	V
		$V_{CC} = 2.7\text{ V}$ ; $I_{OL} = 24\text{ mA}$	-	0.3	0.5	V
		$V_{CC} = 3.0\text{ V}$ ; $I_{OL} = 16\text{ mA}$	-	0.25	0.4	V
		$V_{CC} = 3.0\text{ V}$ ; $I_{OL} = 32\text{ mA}$	-	0.3	0.5	V
		$V_{CC} = 3.0\text{ V}$ ; $I_{OL} = 64\text{ mA}$	-	0.4	0.55	V
$V_{OL(pu)}$	power-up LOW-level output voltage	$V_{CC} = 3.6\text{ V}$ ; $I_O = 1\text{ mA}$ ; $V_I = \text{GND or } V_{CC}$ <sup>[2]</sup>	-	0.13	0.55	V
$I_I$	input leakage current	input pins				
		$V_{CC} = 0\text{ V or }3.6\text{ V}$ ; $V_I = 5.5\text{ V}$	-	1	10	$\mu\text{A}$
		control pins				
		$V_{CC} = 3.6\text{ V}$ ; $V_I = V_{CC}\text{ or GND}$	-	$\pm 0.1$	$\pm 1$	$\mu\text{A}$
		data pins <sup>[3]</sup>				
		$V_{CC} = 3.6\text{ V}$ ; $V_I = V_{CC}$	-	0.1	1	$\mu\text{A}$
	$V_{CC} = 3.6\text{ V}$ ; $V_I = 0\text{ V}$	-5	-1	-	$\mu\text{A}$	
$I_{OFF}$	power-off leakage current	$V_{CC} = 0\text{ V}$ ; $V_I\text{ or }V_O = 0\text{ V to }4.5\text{ V}$	-	1	$\pm 100$	$\mu\text{A}$
$I_{LO}$	output leakage current	$V_{CC} = 3.0\text{ V}$ ; $V_O = 5.5\text{ V}$ ; output HIGH	-	60	125	$\mu\text{A}$
$I_{BHL}$	bus hold LOW current	$V_{CC} = 3.0\text{ V}$ ; $V_I = 0.8\text{ V}$	<sup>[4]</sup> 75	150	-	$\mu\text{A}$
$I_{BHH}$	bus hold HIGH current	$V_{CC} = 3.0\text{ V}$ ; $V_I = 2.0\text{ V}$	-	-150	-75	$\mu\text{A}$
$I_{BHHO}$	bus hold HIGH overdrive current	$V_{CC} = 3.6\text{ V}$ ; $V_I = 0\text{ V to }3.6\text{ V}$	-	-	500	$\mu\text{A}$
$I_{BHLO}$	bus hold LOW overdrive current	$V_{CC} = 3.6\text{ V}$ ; $V_I = 0\text{ V to }3.6\text{ V}$	-500	-	-	$\mu\text{A}$

**Table 6. Static characteristics ...continued**

At recommended operating conditions. Voltages are referenced to GND (ground = 0 V).

Symbol	Parameter	Conditions	-40 °C to +85 °C			Unit
			Min	Typ <sup>[1]</sup>	Max	
I <sub>CC</sub>	supply current	V <sub>CC</sub> = 3.6 V; V <sub>I</sub> = V <sub>CC</sub> or GND; I <sub>O</sub> = 0 A				
		outputs HIGH	-	0.13	0.19	mA
		outputs LOW	-	3	12	mA
ΔI <sub>CC</sub>	additional supply current	per input pin; V <sub>CC</sub> = 3.0 V to 3.6 V; one input = V <sub>CC</sub> - 0.6 V other inputs at V <sub>CC</sub> or GND	[5]	0.1	0.2	mA
C <sub>I</sub>	input capacitance	V <sub>I</sub> = 0 V or 3.0 V	-	4	-	pF

[1] All typical values are measured at V<sub>CC</sub> = 3.3 V (unless stated otherwise) and T<sub>amb</sub> = 25 °C.

[2] For valid test results data must not be loaded into the flip-flops (or latches) after applying the power.

[3] Unused pins at V<sub>CC</sub> or GND.

[4] This is the bus hold overdrive current required to force the input to the opposite logic state.

[5] Increase in supply current for each input at the specified voltage level other than V<sub>CC</sub> or GND

## 10. Dynamic characteristics

**Table 7. Dynamic characteristics**

Voltages are referenced to GND (ground = 0 V). For test circuit see [Figure 9](#).

Symbol	Parameter	Conditions	-40 °C to +85 °C			Unit
			Min	Typ <sup>[1]</sup>	Max	
t <sub>PLH</sub>	LOW to HIGH propagation delay	CP to Qn; <a href="#">Figure 6</a>				
		V <sub>CC</sub> = 2.7 V	-	-	6.3	ns
		V <sub>CC</sub> = 3.3 V ± 0.3 V	1.7	3.5	5.5	ns
t <sub>PHL</sub>	HIGH to LOW propagation delay	CP to Qn; <a href="#">Figure 6</a>				
		V <sub>CC</sub> = 2.7 V	-	-	5.9	ns
		V <sub>CC</sub> = 3.3 V ± 0.3 V	1.9	3.5	5.5	ns
		MR to Qn; see <a href="#">Figure 7</a>				
		V <sub>CC</sub> = 2.7 V	-	-	6.2	ns
		V <sub>CC</sub> = 3.3 V ± 0.3 V	1.3	3.2	6.2	ns
t <sub>su</sub>	set-up time	Dn to CP HIGH; see <a href="#">Figure 7</a> [2]				
		V <sub>CC</sub> = 2.7 V	2.7	-	-	ns
		V <sub>CC</sub> = 3.3 V ± 0.3 V	2.3	1.0	-	ns
		Dn to CP LOW; see <a href="#">Figure 7</a>				
		V <sub>CC</sub> = 2.7 V	2.7	-	-	ns
		V <sub>CC</sub> = 3.3 V ± 0.3 V	2.3	1.0	-	ns
t <sub>h</sub>	hold time	Dn to CP HIGH; see <a href="#">Figure 8</a> [3]				
		V <sub>CC</sub> = 2.7 V	0	-	-	ns
		V <sub>CC</sub> = 3.3 V ± 0.3 V	0	-0.6	-	ns
		Dn to CP LOW; see <a href="#">Figure 8</a>				
		V <sub>CC</sub> = 2.7 V	0	-	-	ns
		V <sub>CC</sub> = 3.3 V ± 0.3 V	0	-0.6	-	ns



**Table 7. Dynamic characteristics ...continued**

Voltages are referenced to GND (ground = 0 V). For test circuit see [Figure 9](#).

Symbol	Parameter	Conditions	-40 °C to +85 °C			Unit
			Min	Typ <sup>[1]</sup>	Max	
$t_W$	pulse width	CP input HIGH or LOW; see <a href="#">Figure 6</a> <sup>[4]</sup>				
		$V_{CC} = 2.7\text{ V}$	3.3	-	-	ns
		$V_{CC} = 3.3\text{ V} \pm 0.3\text{ V}$	3.3	1.5	-	ns
		$\overline{MR}$ input LOW; see <a href="#">Figure 7</a>				
		$V_{CC} = 2.7\text{ V}$	3.3	-	-	ns
		$V_{CC} = 3.3\text{ V} \pm 0.3\text{ V}$	3.3	1.5	-	ns
$t_{rec}$	recovery time	see <a href="#">Figure 7</a>				
		$V_{CC} = 2.7\text{ V}$	3.2	-	-	ns
		$V_{CC} = 3.3\text{ V} \pm 0.3\text{ V}$	2.7	1.0	-	ns
$f_{max}$	maximum frequency	CP input; see <a href="#">Figure 7</a>	150	-	-	MHz

[1] Typical values are measured at  $T_{amb} = 25\text{ °C}$  and  $V_{CC} = 3.3\text{ V}$

[2]  $t_{su}$  is the same as  $t_{su(L)}$  and  $t_{su(H)}$

[3]  $t_h$  is the same as  $t_{h(L)}$  and  $t_{h(H)}$

[4]  $t_W$  is the same as  $t_{WL}$  and  $t_{WH}$

## 11. Waveforms

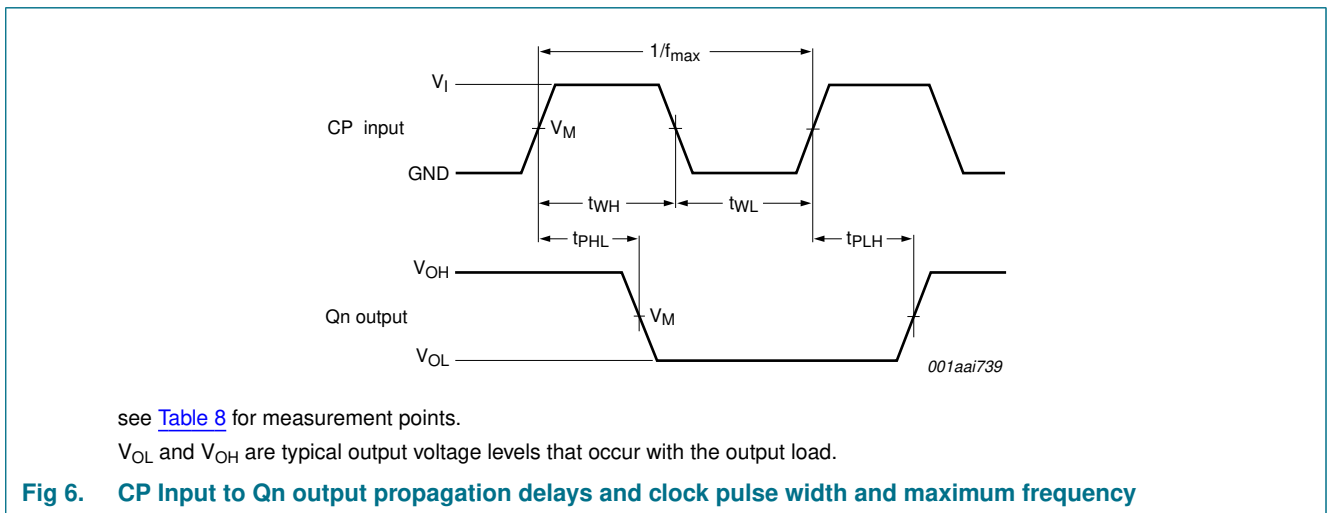

**Table 8. Measurement points**

Input		Output
$V_I$	$V_M$	$V_M$
2.7 V	1.5 V	1.5 V

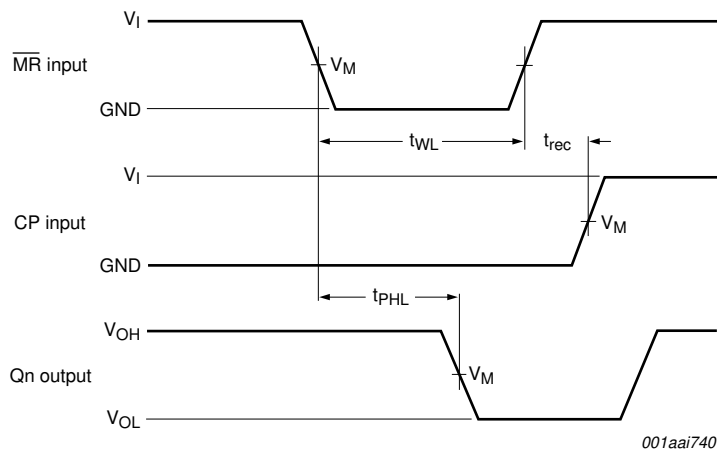

see [Table 8](#) for measurement points.

$V_{OL}$  and  $V_{OH}$  are typical output voltage levels that occur with the output load.

**Fig 7.  $\overline{MR}$  pulse width,  $\overline{MR}$  to CP recovery time and  $\overline{MR}$  to Qn delay**

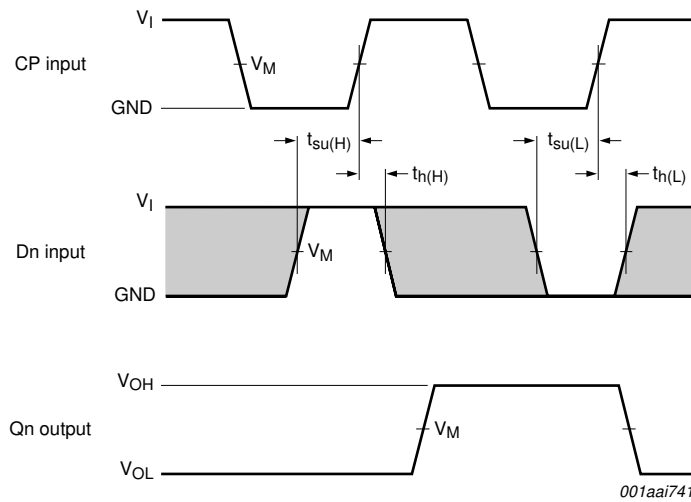

see [Table 8](#) for measurement points.

$V_{OL}$  and  $V_{OH}$  are typical output voltage levels that occur with the output load.

The shaded areas indicate when the input is permitted to change for predicable output performance.

**Fig 8. Data set-up and hold times**

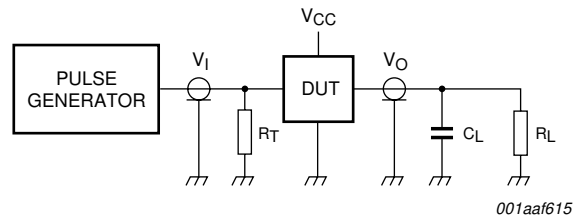
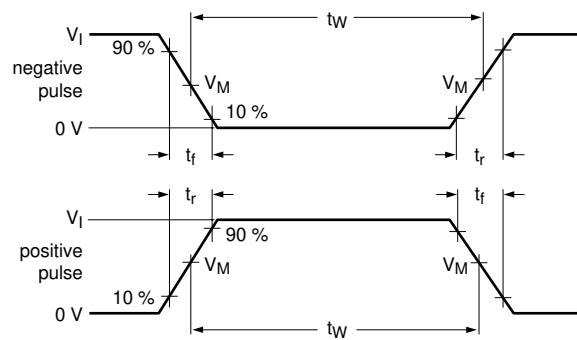

001aaf615

Test data is given in given in [Table 9](#).

Definitions for test circuit:

$R_L$  = Load resistance;

$C_L$  = Load capacitance including jig and probe capacitance;

$R_T$  = Termination resistance should be equal to output impedance  $Z_o$  of the pulse generator.

**Fig 9. Load circuitry for switching times**

**Table 9. Test data**

Input				Load	
$V_I$	Repetition rate	$t_W$	$t_r, t_f$	$R_L$	$C_L$
2.7 V	≤ 10 MHz	500 ns	≤ 2.5 ns	500 Ω	50 pF

12. Package outline

SO20: plastic small outline package; 20 leads; body width 7.5 mm

SOT163-1

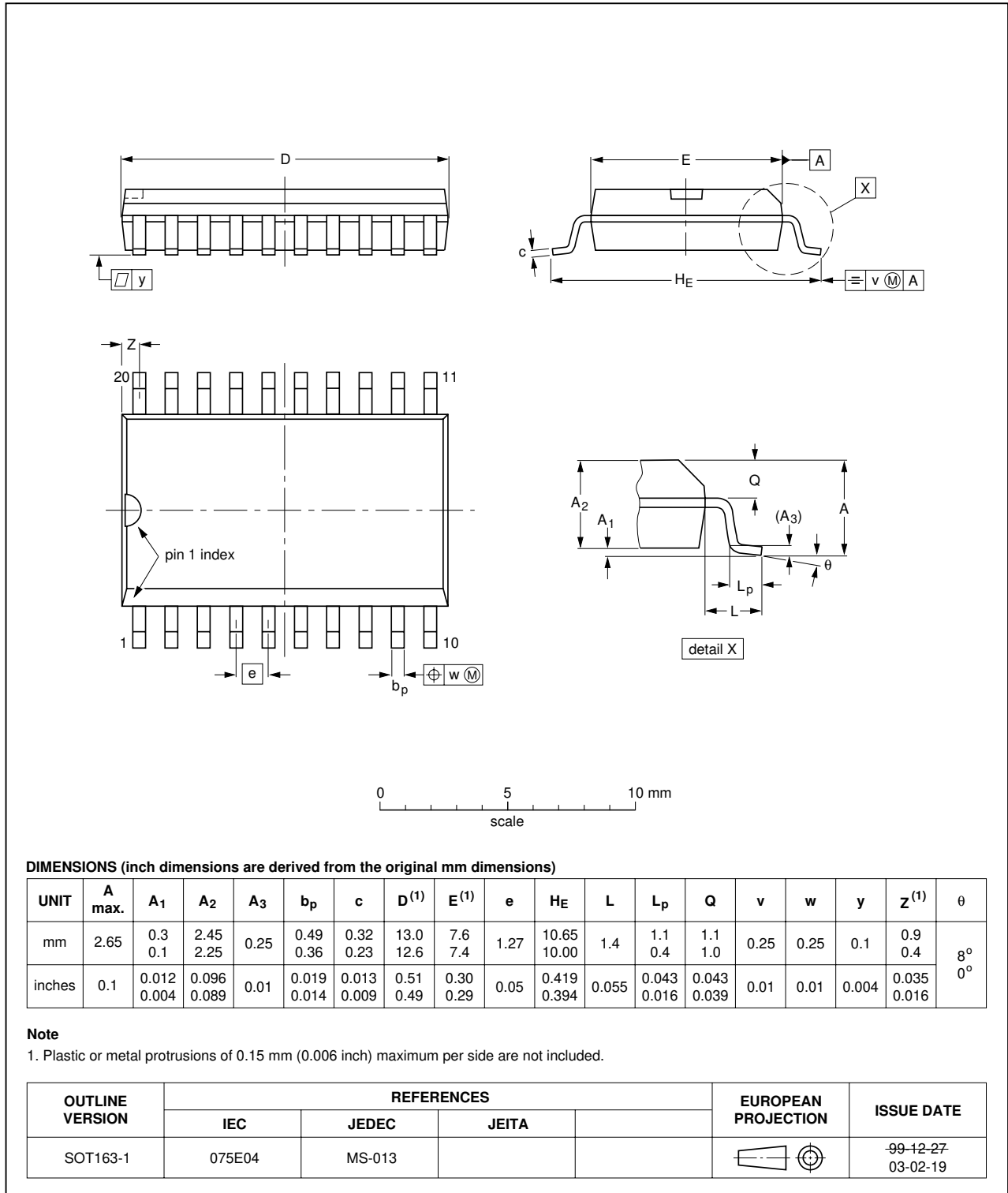

Fig 10. Package outline SOT163-1 (SO20)

SSOP20: plastic shrink small outline package; 20 leads; body width 5.3 mm

SOT339-1

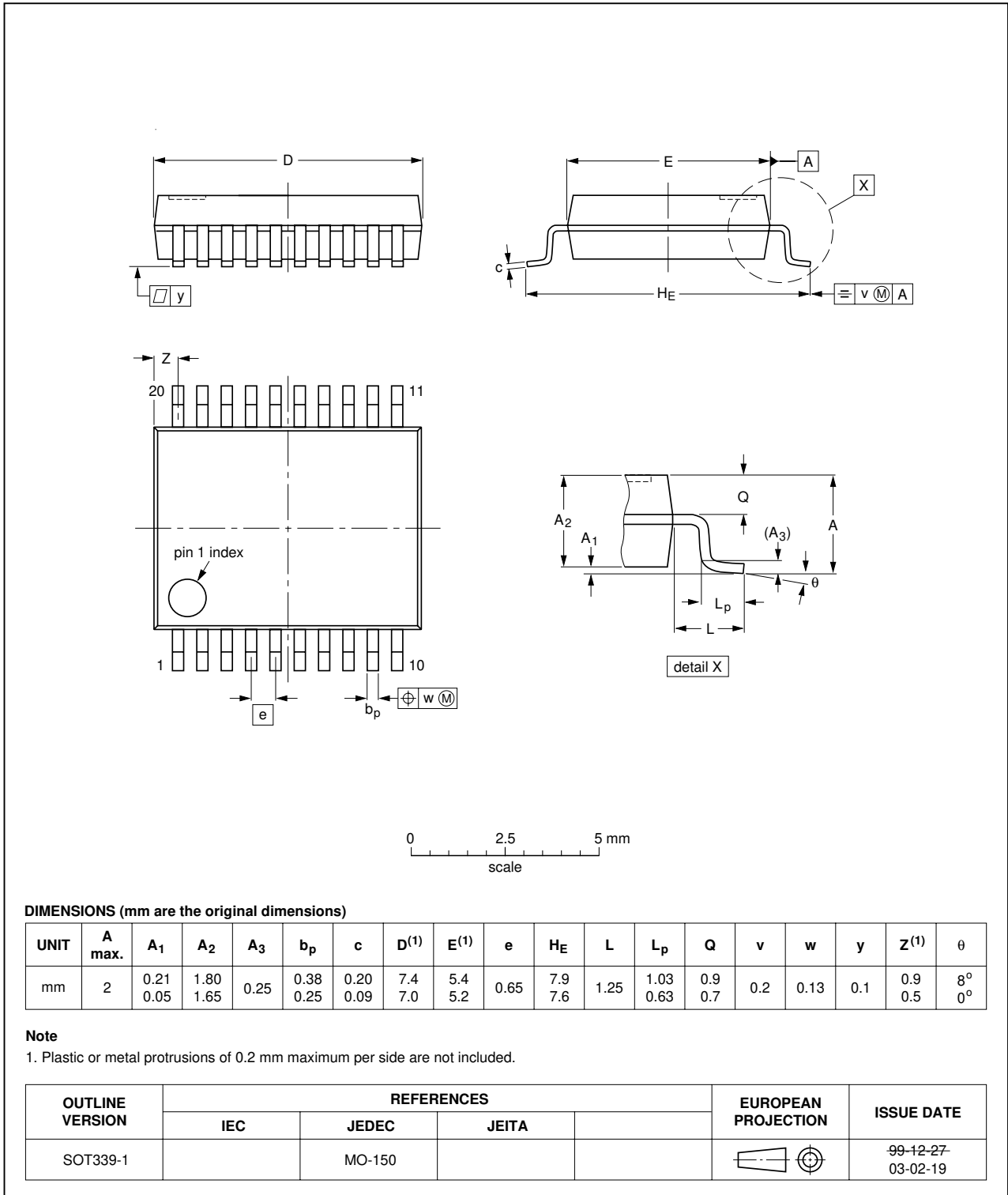

Fig 11. Package outline SOT339-1 (SSOP20)

TSSOP20: plastic thin shrink small outline package; 20 leads; body width 4.4 mm

SOT360-1

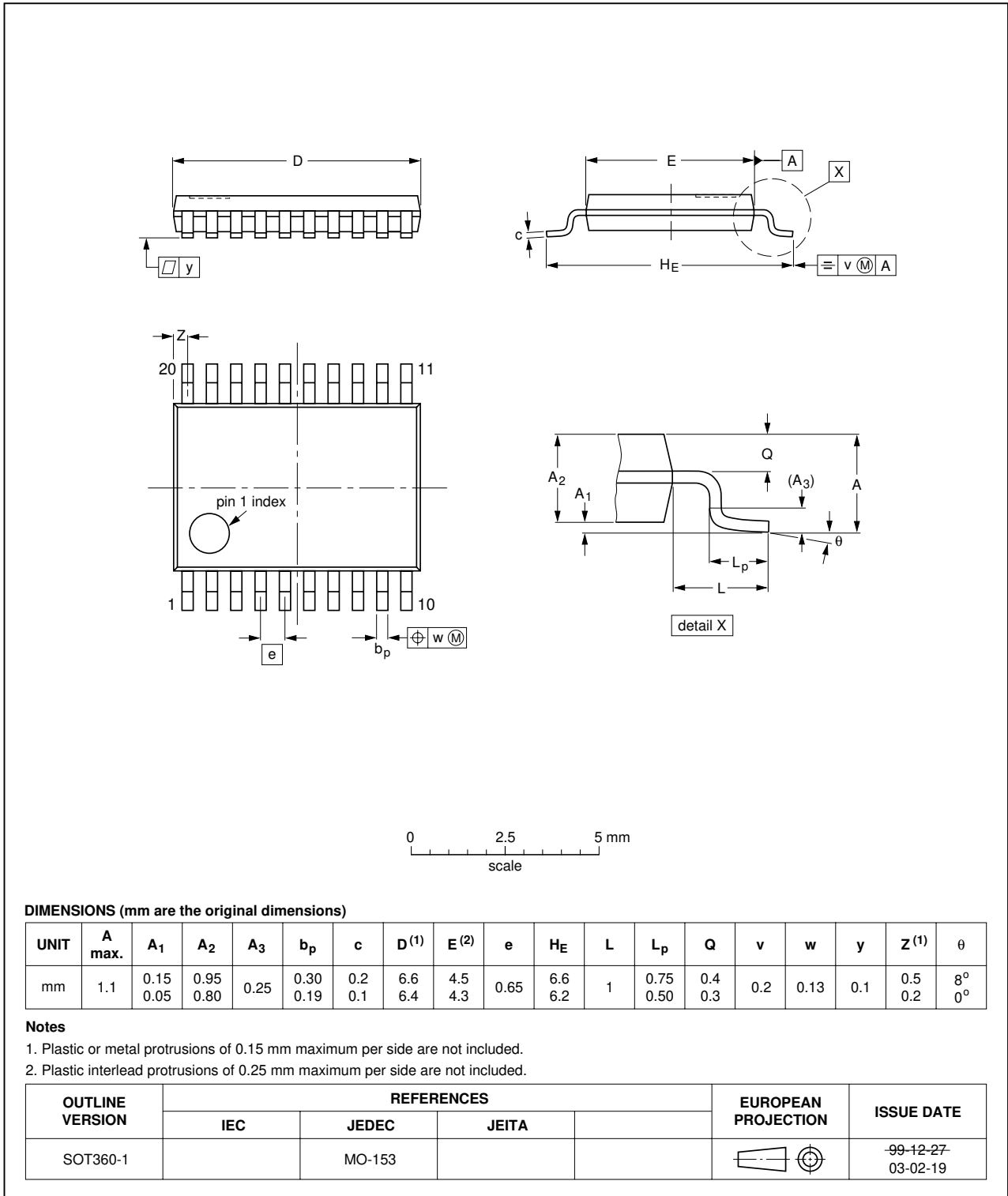

Fig 12. Package outline SOT360-1 (TSSOP20)

DHVQFN20: plastic dual in-line compatible thermal enhanced very thin quad flat package; no leads; 20 terminals; body 2.5 x 4.5 x 0.85 mm

SOT764-1

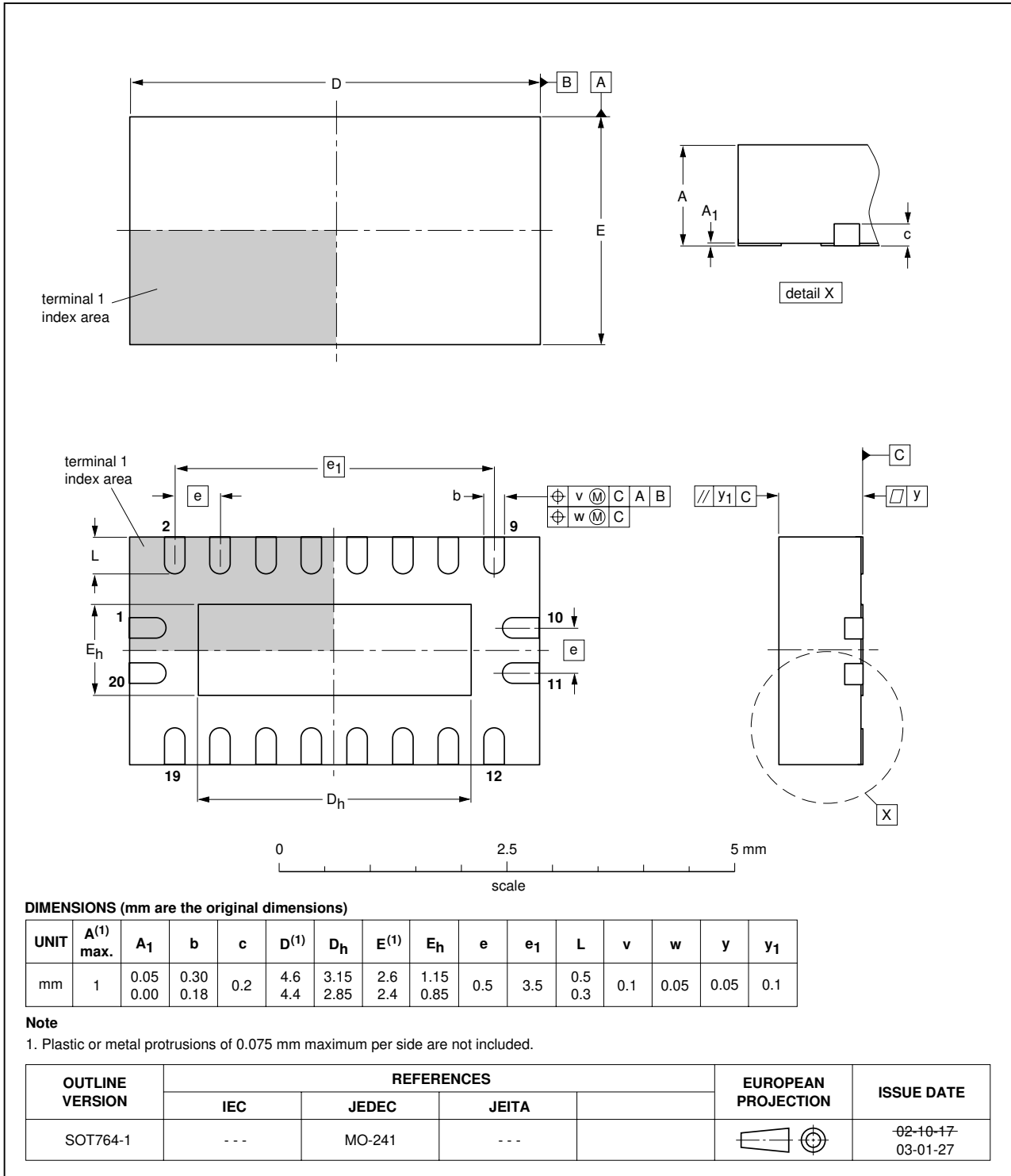

Fig 13. Package outline SOT764-1 (DHVQFN20)

## 13. Abbreviations

**Table 10. Abbreviations**

Acronym	Description
BiCMOS	Integrated Bipolar junction transistors and CMOS
CDM	Charged Device Model
DUT	Device Under Test
ESD	ElectroStatic Discharge
HBM	Human Body Model
TTL	Transistor-Transistor Logic

## 14. Revision history

**Table 11. Revision history**

Document ID	Release date	Data sheet status	Change notice	Supersedes
74LVT273_3	20080910	Product data sheet	-	74LVT273_2
Modifications:	<ul style="list-style-type: none"> <li>The format of this data sheet has been redesigned to comply with the new identity guidelines of NXP Semiconductors.</li> <li>Legal texts have been adapted to the new company name where appropriate.</li> <li>Title changed to 3.3 V octal D-type flip-flop</li> <li><a href="#">Section 3 "Ordering information"</a> and <a href="#">Section 12 "Package outline"</a> DHVQFN20 package added.</li> <li><a href="#">Table 4 "Limiting values"</a> <math>T_j</math> and <math>P_{tot}</math> values added.</li> </ul>			
74LVT273_2	19980219	Product specification	-	-



## 15. Legal information

## 16. Data sheet status

Document status <sup>[1][2]</sup>	Product status <sup>[3]</sup>	Definition
Objective [short] data sheet	Development	This document contains data from the objective specification for product development.
Preliminary [short] data sheet	Qualification	This document contains data from the preliminary specification.
Product [short] data sheet	Production	This document contains the product specification.

[1] Please consult the most recently issued document before initiating or completing a design.

[2] The term 'short data sheet' is explained in section "Definitions".

[3] The product status of device(s) described in this document may have changed since this document was published and may differ in case of multiple devices. The latest product status information is available on the Internet at URL <http://www.nxp.com>.

### 16.1 Definitions

**Draft** — The document is a draft version only. The content is still under internal review and subject to formal approval, which may result in modifications or additions. NXP Semiconductors does not give any representations or warranties as to the accuracy or completeness of information included herein and shall have no liability for the consequences of use of such information.

**Short data sheet** — A short data sheet is an extract from a full data sheet with the same product type number(s) and title. A short data sheet is intended for quick reference only and should not be relied upon to contain detailed and full information. For detailed and full information see the relevant full data sheet, which is available on request via the local NXP Semiconductors sales office. In case of any inconsistency or conflict with the short data sheet, the full data sheet shall prevail.

### 16.2 Disclaimers

**General** — Information in this document is believed to be accurate and reliable. However, NXP Semiconductors does not give any representations or warranties, expressed or implied, as to the accuracy or completeness of such information and shall have no liability for the consequences of use of such information.

**Right to make changes** — NXP Semiconductors reserves the right to make changes to information published in this document, including without limitation specifications and product descriptions, at any time and without notice. This document supersedes and replaces all information supplied prior to the publication hereof.

**Suitability for use** — NXP Semiconductors products are not designed, authorized or warranted to be suitable for use in medical, military, aircraft, space or life support equipment, nor in applications where failure or

malfunction of an NXP Semiconductors product can reasonably be expected to result in personal injury, death or severe property or environmental damage. NXP Semiconductors accepts no liability for inclusion and/or use of NXP Semiconductors products in such equipment or applications and therefore such inclusion and/or use is at the customer's own risk.

**Applications** — Applications that are described herein for any of these products are for illustrative purposes only. NXP Semiconductors makes no representation or warranty that such applications will be suitable for the specified use without further testing or modification.

**Limiting values** — Stress above one or more limiting values (as defined in the Absolute Maximum Ratings System of IEC 60134) may cause permanent damage to the device. Limiting values are stress ratings only and operation of the device at these or any other conditions above those given in the Characteristics sections of this document is not implied. Exposure to limiting values for extended periods may affect device reliability.

**Terms and conditions of sale** — NXP Semiconductors products are sold subject to the general terms and conditions of commercial sale, as published at <http://www.nxp.com/profile/terms>, including those pertaining to warranty, intellectual property rights infringement and limitation of liability, unless explicitly otherwise agreed to in writing by NXP Semiconductors. In case of any inconsistency or conflict between information in this document and such terms and conditions, the latter will prevail.

**No offer to sell or license** — Nothing in this document may be interpreted or construed as an offer to sell products that is open for acceptance or the grant, conveyance or implication of any license under any copyrights, patents or other industrial or intellectual property rights.

### 16.3 Trademarks

Notice: All referenced brands, product names, service names and trademarks are the property of their respective owners.

## 17. Contact information

For more information, please visit: <http://www.nxp.com>

For sales office addresses, please send an email to: [salesaddresses@nxp.com](mailto:salesaddresses@nxp.com)

**18. Contents**

1 **General description** . . . . . 1

2 **Features** . . . . . 1

3 **Ordering information** . . . . . 2

4 **Functional diagram** . . . . . 2

5 **Pinning information** . . . . . 4

5.1 Pinning . . . . . 4

5.2 Pin description . . . . . 4

6 **Functional description** . . . . . 5

7 **Limiting values** . . . . . 5

8 **Recommended operating conditions** . . . . . 5

9 **Static characteristics** . . . . . 6

10 **Dynamic characteristics** . . . . . 7

11 **Waveforms** . . . . . 8

12 **Package outline** . . . . . 11

13 **Abbreviations** . . . . . 15

14 **Revision history** . . . . . 15

15 **Legal information** . . . . . 16

16 Data sheet status . . . . . 16

16.1 Definitions . . . . . 16

16.2 Disclaimers . . . . . 16

16.3 Trademarks . . . . . 16

17 **Contact information** . . . . . 16

18 **Contents** . . . . . 17

Please be aware that important notices concerning this document and the product(s) described herein, have been included in section 'Legal information'.



© NXP B.V. 2008.

All rights reserved.

For more information, please visit: <http://www.nxp.com>

For sales office addresses, please send an email to: [salesaddresses@nxp.com](mailto:salesaddresses@nxp.com)

Date of release: 10 September 2008

Document identifier: 74LVT273\_3