



Chipsmall Limited consists of a professional team with an average of over 10 year of expertise in the distribution of electronic components. Based in Hongkong, we have already established firm and mutual-benefit business relationships with customers from,Europe,America and south Asia,supplying obsolete and hard-to-find components to meet their specific needs.

With the principle of "Quality Parts,Customers Priority,Honest Operation,and Considerate Service",our business mainly focus on the distribution of electronic components. Line cards we deal with include Microchip,ALPS,ROHM,Xilinx,Pulse,ON,Everlight and Freescale. Main products comprise IC,Modules,Potentiometer,IC Socket,Relay,Connector.Our parts cover such applications as commercial,industrial, and automotives areas.

We are looking forward to setting up business relationship with you and hope to provide you with the best service and solution. Let us make a better world for our industry!



Contact us

Tel: +86-755-8981 8866 Fax: +86-755-8427 6832

Email & Skype: info@chipsmall.com Web: www.chipsmall.com

Address: A1208, Overseas Decoration Building, #122 Zhenhua RD., Futian, Shenzhen, China



SINGLE 2-INPUT NOR GATE

- 5V TOLERANT INPUTS
- HIGH SPEED: $t_{PD} = 4.2\text{ns}$ (MAX.) at $V_{CC} = 3\text{V}$
- LOW POWER DISSIPATION:
 $I_{CC} = 1\mu\text{A}$ (MAX.) at $T_A = 25^\circ\text{C}$
- POWER DOWN PROTECTION ON INPUTS AND OUTPUTS
- SYMMETRICAL OUTPUT IMPEDANCE:
 $|I_{OH}| = I_{OL} = 24\text{mA}$ (MIN) at $V_{CC} = 3\text{V}$
- BALANCED PROPAGATION DELAYS:
 $t_{PLH} \cong t_{PHL}$
- OPERATING VOLTAGE RANGE:
 $V_{CC}(\text{OPR}) = 1.65\text{V to } 5.5\text{V}$
(1.2V Data Retention)
- IMPROVED LATCH-UP IMMUNITY

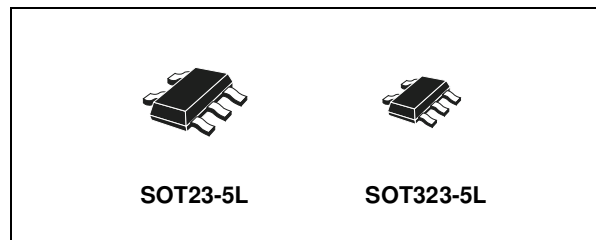

ORDER CODES

| PACKAGE | T & R |
|-----------|-------------|
| SOT23-5L | 74LX1G02STR |
| SOT323-5L | 74LX1G02CTR |

DESCRIPTION

The 74LX1G02 is a low voltage CMOS SINGLE 2-INPUT NOR GATE fabricated with sub-micron silicon gate and double-layer metal wiring C²MOS technology.

The internal circuit is composed of 3 stages including buffer output, which provide high noise immunity and stable output.

Power down protection is provided on all inputs and 0 to 7V can be accepted on inputs with no regard to the supply voltage. This device can be used to interface 5V to 3V.

All inputs and outputs are equipped with protection circuits against static discharge.

PIN CONNECTION AND IEC LOGIC SYMBOLS

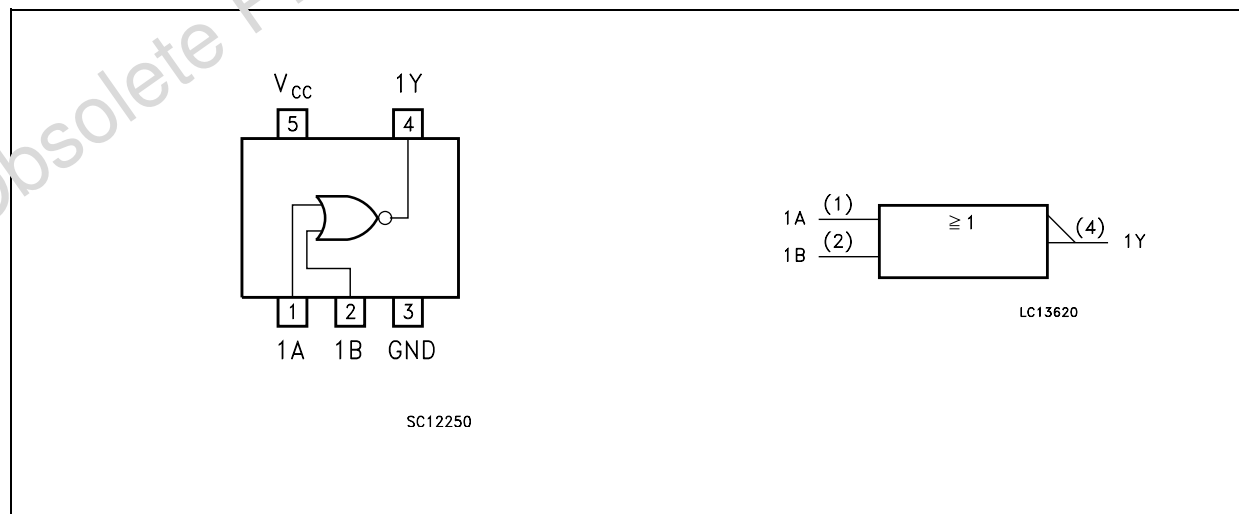

74LX1G02

INPUT AND OUTPUT EQUIVALENT CIRCUIT

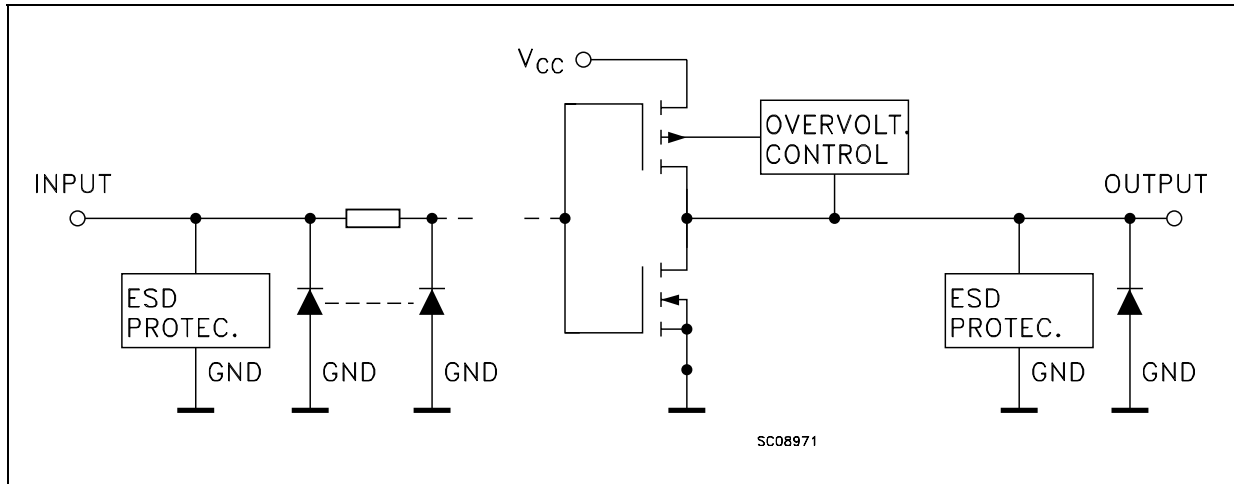

PIN DESCRIPTION

| PIN No | SYMBOL | NAME AND FUNCTION |
|--------|-----------------|-------------------------|
| 1 | 1A | Data Input |
| 2 | 1B | Data Input |
| 4 | 1Y | Data Output |
| 3 | GND | Ground (0V) |
| 5 | V _{CC} | Positive Supply Voltage |

TRUTH TABLE

| A | B | Y |
|---|---|---|
| L | L | H |
| L | H | L |
| H | L | L |
| H | H | L |

ABSOLUTE MAXIMUM RATINGS

| Symbol | Parameter | Value | Unit |
|-------------------------------------|-----------------------------------------------------|-------------------------------|------|
| V _{CC} | Supply Voltage | -0.5 to +7.0 | V |
| V _I | DC Input Voltage | -0.5 to +7.0 | V |
| V _O | DC Output Voltage (V _{CC} = 0V) | -0.5 to +7.0 | V |
| V _O | DC Output Voltage (High or Low State) (note 1) | -0.5 to V _{CC} + 0.5 | V |
| I _{IK} | DC Input Diode Current | - 50 | mA |
| I _{OK} | DC Output Diode Current (note 2) | - 50 | mA |
| I _O | DC Output Current | ± 50 | mA |
| I _{CC} or I _{GND} | DC V _{CC} or Ground Current per Supply Pin | ± 50 | mA |
| T _{stg} | Storage Temperature | -65 to +150 | °C |
| T _L | Lead Temperature (10 sec) | 300 | °C |

Absolute Maximum Ratings are those values beyond which damage to the device may occur. Functional operation under these conditions is not implied.

1) I_O absolute maximum rating must be observed

2) V_O < GND, V_O > V_{CC}

RECOMMENDED OPERATING CONDITIONS

| Symbol | Parameter | Value | Unit |
|------------------|----------------------------------------------------------------|---------------|-------------|
| V_{CC} | Supply Voltage (note 1) | 1.65 to 5.5 | V |
| V_I | Input Voltage | 0 to 5.5 | V |
| V_O | Output Voltage ($V_{CC} = 0V$) | 0 to 5.5 | V |
| V_O | Output Voltage (High or Low State) | 0 to V_{CC} | V |
| I_{OH}, I_{OL} | High or Low Level Output Current ($V_{CC} = 4.5$ to $5.5V$) | ± 32 | mA |
| I_{OH}, I_{OL} | High or Low Level Output Current ($V_{CC} = 3.0$ to $3.6V$) | ± 24 | mA |
| I_{OH}, I_{OL} | High or Low Level Output Current ($V_{CC} = 2.7$ to $3.0V$) | ± 12 | mA |
| I_{OH}, I_{OL} | High or Low Level Output Current ($V_{CC} = 2.3$ to $2.7V$) | ± 8 | mA |
| I_{OH}, I_{OL} | High or Low Level Output Current ($V_{CC} = 1.65$ to $2.3V$) | ± 4 | mA |
| T_{op} | Operating Temperature | -40 to 85 | $^{\circ}C$ |
| dt/dv | Input Rise and Fall Time (note 2) | 0 to 10 | ns/V |

1) Truth Table guaranteed: 1.2V to 3.6V

2) V_{IN} from 0.8V to 2V at $V_{CC} = 3.0V$

DC SPECIFICATIONS

| Symbol | Parameter | Test Condition | | Value | | | | Unit |
|-----------|---------------------------|-----------------|------------------------|-----------------------|--------------|------------------------|--------------|---------|
| | | V_{CC} (V) | | -40 to 85 $^{\circ}C$ | | -55 to 125 $^{\circ}C$ | | |
| | | | | Min. | Max. | Min. | Max. | |
| V_{IH} | High Level Input Voltage | 1.65 to 1.95 | | $0.75V_{CC}$ | | $0.75V_{CC}$ | | V |
| | | 2.3 to 2.7 | | $0.7V_{CC}$ | | $0.7V_{CC}$ | | |
| | | 3.0 to 5.5 | | $0.7V_{CC}$ | | $0.7V_{CC}$ | | |
| V_{IL} | Low Level Input Voltage | 1.65 to 1.95 | | | $0.25V_{CC}$ | | $0.25V_{CC}$ | V |
| | | 2.3 to 2.7 | | | $0.3V_{CC}$ | | $0.3V_{CC}$ | |
| | | 3.0 to 5.5 | | | $0.3V_{CC}$ | | $0.3V_{CC}$ | |
| V_{OH} | High Level Output Voltage | 1.65 to 4.5 | $I_O = -100 \mu A$ | $V_{CC} - 0.1$ | | $V_{CC} - 0.1$ | | V |
| | | 1.65 | $I_O = -4 \text{ mA}$ | 1.2 | | 1.2 | | |
| | | 2.3 | $I_O = -8 \text{ mA}$ | 1.9 | | 1.9 | | |
| | | 3.0 | $I_O = -16 \text{ mA}$ | 2.4 | | 2.4 | | |
| | | | $I_O = -24 \text{ mA}$ | 2.2 | | 2.2 | | |
| 4.5 | $I_O = -32 \text{ mA}$ | 3.8 | | 3.8 | | | | |
| V_{OL} | Low Level Output Voltage | 1.65 to 4.5 | $I_O = 100 \mu A$ | | 0.1 | | 0.1 | V |
| | | 1.65 | $I_O = 4 \text{ mA}$ | | 0.45 | | 0.45 | |
| | | 2.3 | $I_O = 8 \text{ mA}$ | | 0.3 | | 0.3 | |
| | | 3.0 | $I_O = 16 \text{ mA}$ | | 0.4 | | 0.4 | |
| | | | $I_O = 24 \text{ mA}$ | | 0.55 | | 0.55 | |
| 4.5 | $I_O = 32 \text{ mA}$ | | 0.55 | | 0.55 | | | |
| I_I | Input Leakage Current | 1.65 to 5.5 | $V_I = 0$ to $5.5V$ | | ± 10 | | ± 10 | μA |
| I_{off} | Power Off Leakage Current | 0 | V_I or $V_O = 5.5V$ | | 10 | | 10 | μA |
| I_{CC} | Quiescent Supply Current | 1.65 to 5.5 | $V_I = V_{CC}$ or GND | | 10 | | 10 | μA |

74LX1G02

AC ELECTRICAL CHARACTERISTICS (Input $t_r = t_f = 3\text{ns}$)

| Symbol | Parameter | Test Condition | | | | Value | | | | Unit |
|---------------------|------------------------|-----------------|---------------|-----------------------|---------------------|--------------|------|---------------|------|------|
| | | V_{CC} (V) | C_L (pF) | R_L (Ω) | $t_s = t_r$ (ns) | -40 to 85 °C | | -55 to 125 °C | | |
| | | | | | | Min. | Max. | Min. | Max. | |
| t_{PLH} t_{PHL} | Propagation Delay Time | 1.65 to 1.95 | 15 | 1M Ω | 3.0 | 2 | 12.0 | 2 | 12.0 | ns |
| | | 2.3 to 2.7 | | | | 2 | 7.0 | 2 | 7.0 | |
| | | 3.0 to 3.6 | | | | 1 | 4.7 | 1 | 4.7 | |
| | | 4.5 to 5.5 | | | | 1 | 4.1 | 1 | 4.1 | |
| | | 1.65 to 1.95 | 30 | 1000 | 2.0 | 2 | 7.5 | 2 | 7.5 | |
| | | 2.3 to 2.7 | 30 | 500 | 2.0 | 2 | 5.5 | 2 | 5.5 | |
| | | 2.7 | 50 | 500 | 2.5 | 1 | 5.2 | 1 | 5.2 | |
| | | 3.0 to 3.6 | 50 | 500 | 2.5 | 1 | 4.2 | 1 | 4.2 | |
| | | 4.5 to 5.5 | 50 | 500 | 2.5 | 1 | 3.7 | 1 | 3.7 | |

CAPACITIVE CHARACTERISTICS

| Symbol | Parameter | Test Condition | | Value | | | Unit |
|----------|-------------------------------------------|-----------------|-------------------------|----------------------|------|------|------|
| | | V_{CC} (V) | | $T_A = 25\text{ °C}$ | | | |
| | | | | Min. | Typ. | Max. | |
| C_{IN} | Input Capacitance | 0 | | | 4 | | pF |
| C_{PD} | Power Dissipation Capacitance (note 1) | 1.8 | $f_{IN} = 10\text{MHz}$ | | 21 | | pF |
| | | 2.5 | | | 24 | | |
| | | 3.3 | | | 26 | | |

1) C_{PD} is defined as the value of the IC's internal equivalent capacitance which is calculated from the operating current consumption without load. (Refer to Test Circuit). Average operating current can be obtained by the following equation. $I_{CC(opr)} = C_{PD} \times V_{CC} \times f_{IN} + I_{CC}$

TEST CIRCUIT

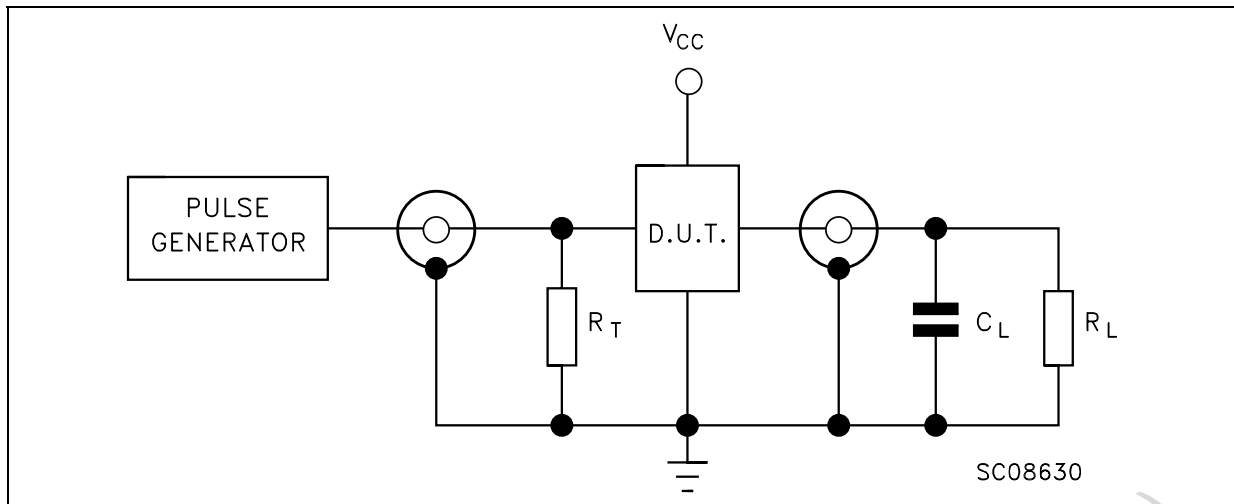

$R_T = Z_{OUT}$ of pulse generator (typically 50 Ω)

TEST CIRCUIT AND WAVEFORM SYMBOL VALUE

| Symbol | V_{CC} | | |
|-------------|----------------------------|---------------------------|---------------------------|
| | 1.65 to 1.95V | 2.3 to 2.7V | 2.7 to 5.5V |
| C_L | 15pF/30pF | 15pF/30pF | 15pF/50pF |
| R_L | 1M Ω /1000 Ω | 1M Ω /500 Ω | 1M Ω /500 Ω |
| V_{IH} | V_{CC} | V_{CC} | V_{CC} |
| V_M | $V_{CC}/2$ | $V_{CC}/2$ | $V_{CC}/2$ |
| $t_r = t_f$ | <2.0ns | <2.0ns | <2.5ns |

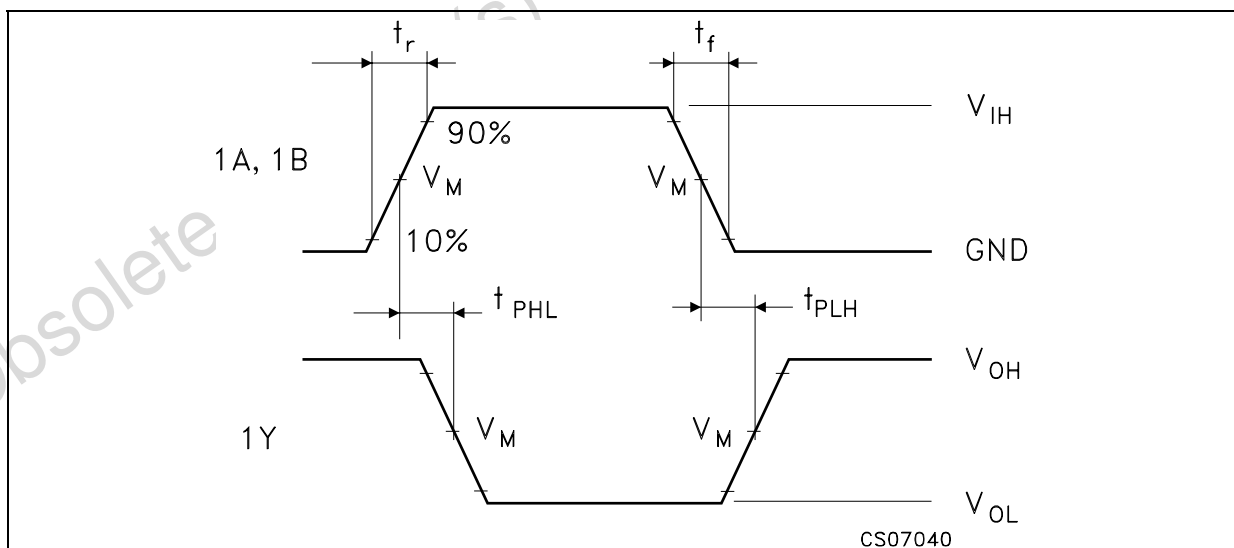
WAVEFORM: PROPAGATION DELAY ($f=1\text{MHz}$; 50% duty cycle)

SOT23-5L MECHANICAL DATA

| DIM. | mm. | | | mils | | |
|------|------|------|------|-------|------|-------|
| | MIN. | TYP | MAX. | MIN. | TYP. | MAX. |
| A | 0.90 | | 1.45 | 35.4 | | 57.1 |
| A1 | 0.00 | | 0.10 | 0.0 | | 3.9 |
| A2 | 0.90 | | 1.30 | 35.4 | | 51.2 |
| b | 0.35 | | 0.50 | 13.7 | | 19.7 |
| C | 0.09 | | 0.20 | 3.5 | | 7.8 |
| D | 2.80 | | 3.00 | 110.2 | | 118.1 |
| E | 1.50 | | 1.75 | 59.0 | | 68.8 |
| e | | 0.95 | | | 37.4 | |
| H | 2.60 | | 3.00 | 102.3 | | 118.1 |
| L | 0.10 | | 0.60 | 3.9 | | 23.6 |

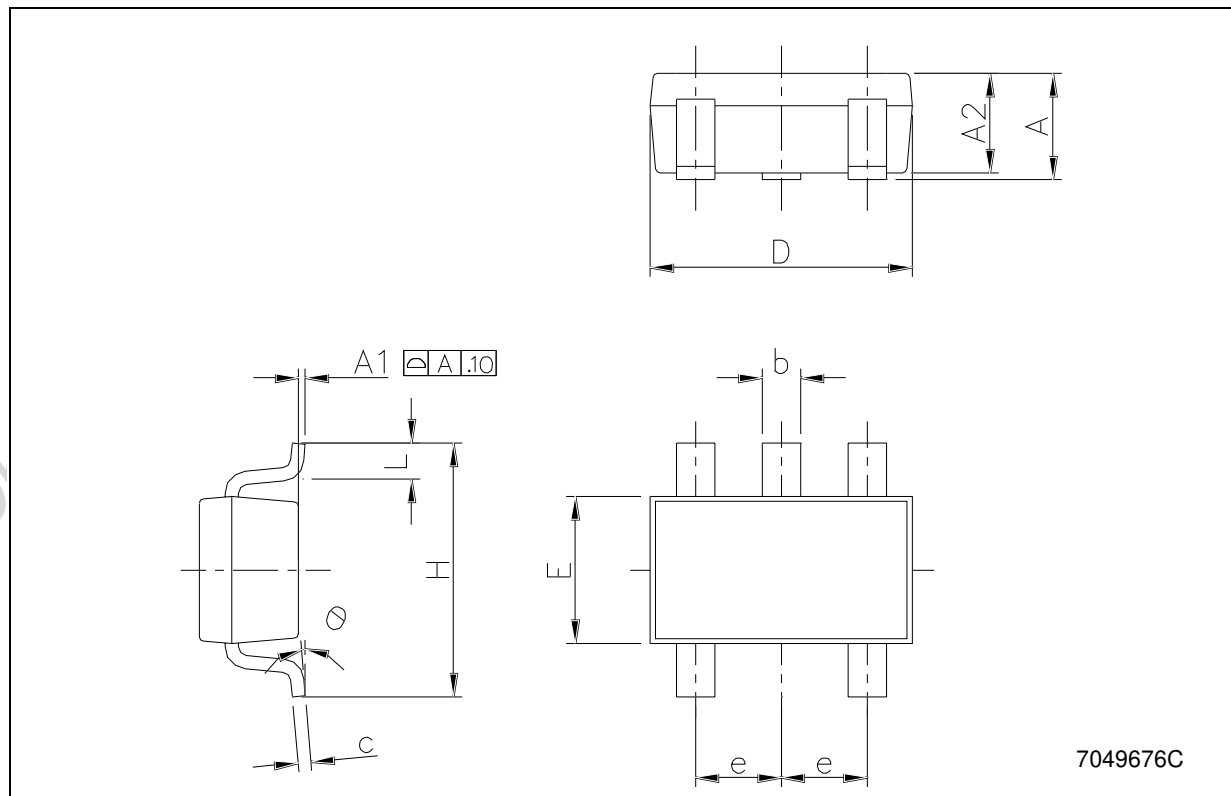

SOT323-5L MECHANICAL DATA

| DIM. | mm. | | | mils | | |
|------|------|------|------|------|------|------|
| | MIN. | TYP | MAX. | MIN. | TYP. | MAX. |
| A | 0.80 | | 1.10 | 31.5 | | 43.3 |
| A1 | 0.00 | | 0.10 | 0.0 | | 3.9 |
| A2 | 0.80 | | 1.00 | 31.5 | | 39.4 |
| b | 0.15 | | 0.30 | 5.9 | | 11.8 |
| C | 0.10 | | 0.18 | 3.9 | | 7.1 |
| D | 1.80 | | 2.20 | 70.9 | | 86.6 |
| E | 1.80 | | 2.40 | 70.9 | | 94.5 |
| E1 | 1.15 | | 1.35 | 45.3 | | 53.1 |
| e | | 0.65 | | | 25.6 | |
| e1 | | 1.3 | | | 51.2 | |
| L | 0.10 | | 0.30 | 3.9 | | 11.8 |

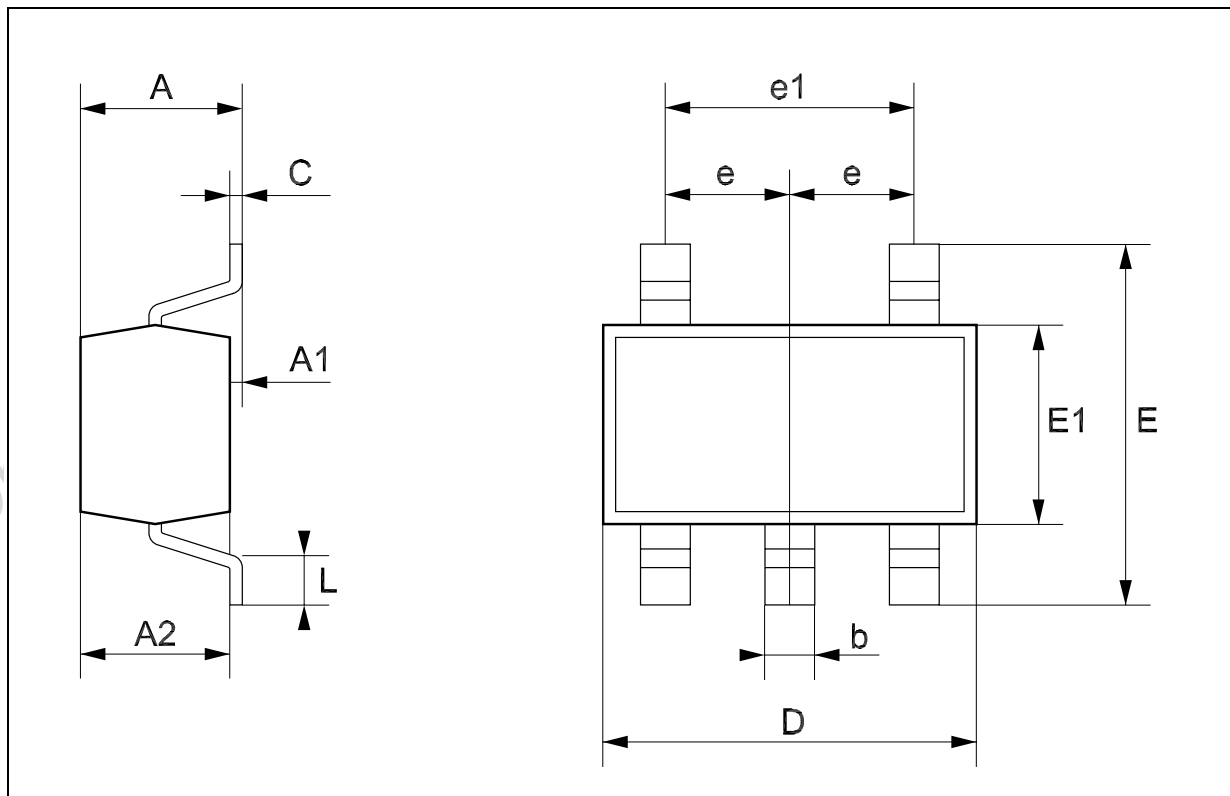

Tape & Reel SOT23-xL MECHANICAL DATA

| DIM. | mm. | | | inch | | |
|------|------|------|------|-------|-------|-------|
| | MIN. | TYP | MAX. | MIN. | TYP. | MAX. |
| A | | | 180 | | | 7.086 |
| C | 12.8 | 13.0 | 13.2 | 0.504 | 0.512 | 0.519 |
| D | 20.2 | | | 0.795 | | |
| N | 60 | | | 2.362 | | |
| T | | | 14.4 | | | 0.567 |
| Ao | 3.13 | 3.23 | 3.33 | 0.123 | 0.127 | 0.131 |
| Bo | 3.07 | 3.17 | 3.27 | 0.120 | 0.124 | 0.128 |
| Ko | 1.27 | 1.37 | 1.47 | 0.050 | 0.054 | 0.058 |
| Po | 3.9 | 4.0 | 4.1 | 0.153 | 0.157 | 0.161 |
| P | 3.9 | 4.0 | 4.1 | 0.153 | 0.157 | 0.161 |

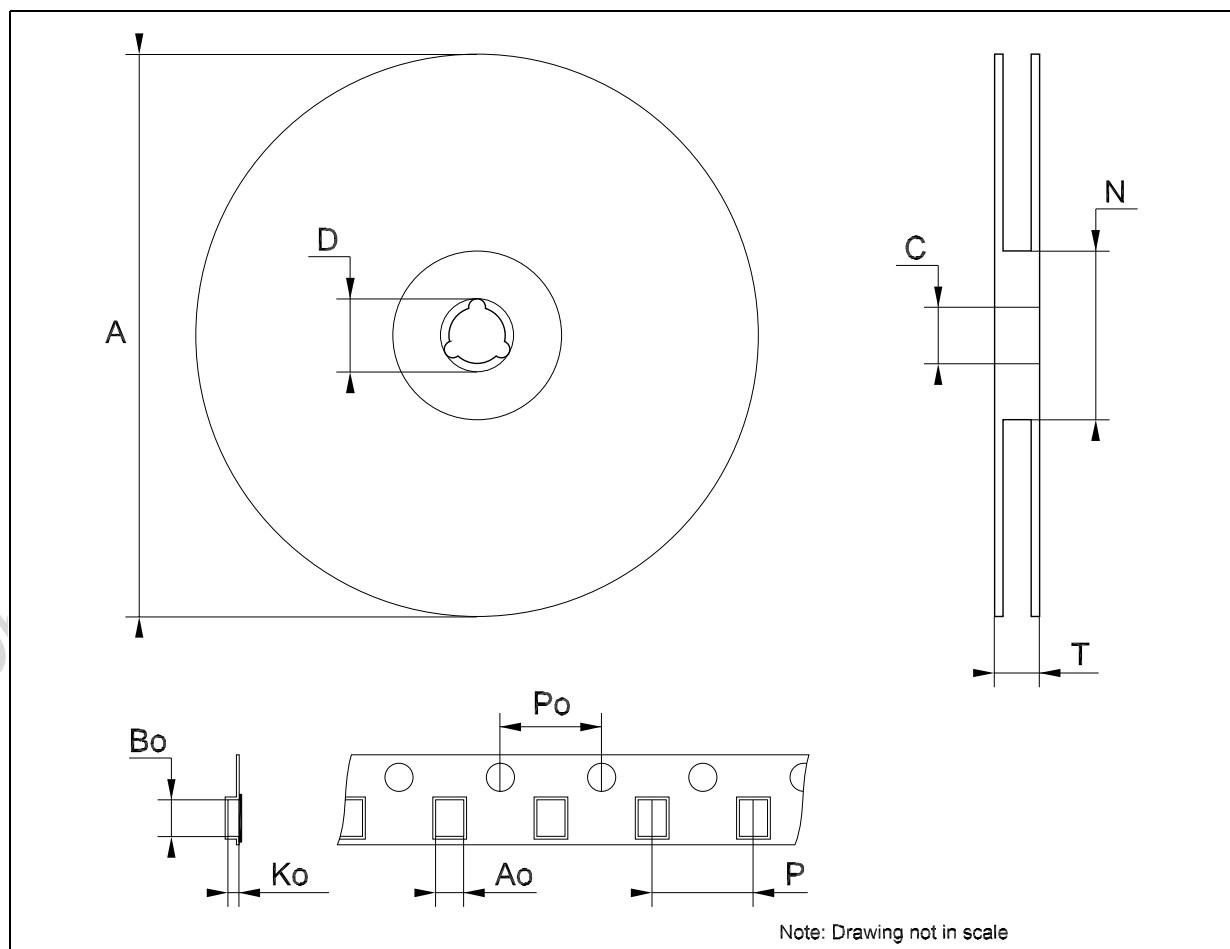

Tape & Reel SOT323-xL MECHANICAL DATA

| DIM. | mm. | | | inch | | |
|------|------|------|------|-------|-------|-------|
| | MIN. | TYP | MAX. | MIN. | TYP. | MAX. |
| A | 175 | 180 | 185 | 6.889 | 7.086 | 7.283 |
| C | 12.8 | 13 | 13.2 | 0.504 | 0.512 | 0.519 |
| D | 20.2 | | | 0.795 | | |
| N | 59.5 | 60 | 60.5 | | 2.362 | |
| T | | | 14.4 | | | 0.567 |
| Ao | | 2.25 | | | 0.088 | |
| Bo | | 2.7 | | | 0.106 | |
| Ko | | 1.2 | | | 0.047 | |
| Po | 3.9 | 4 | 4.1 | 0.153 | 0.157 | 0.161 |
| P | 3.8 | 4 | 4.2 | 0.149 | 0.157 | 0.165 |

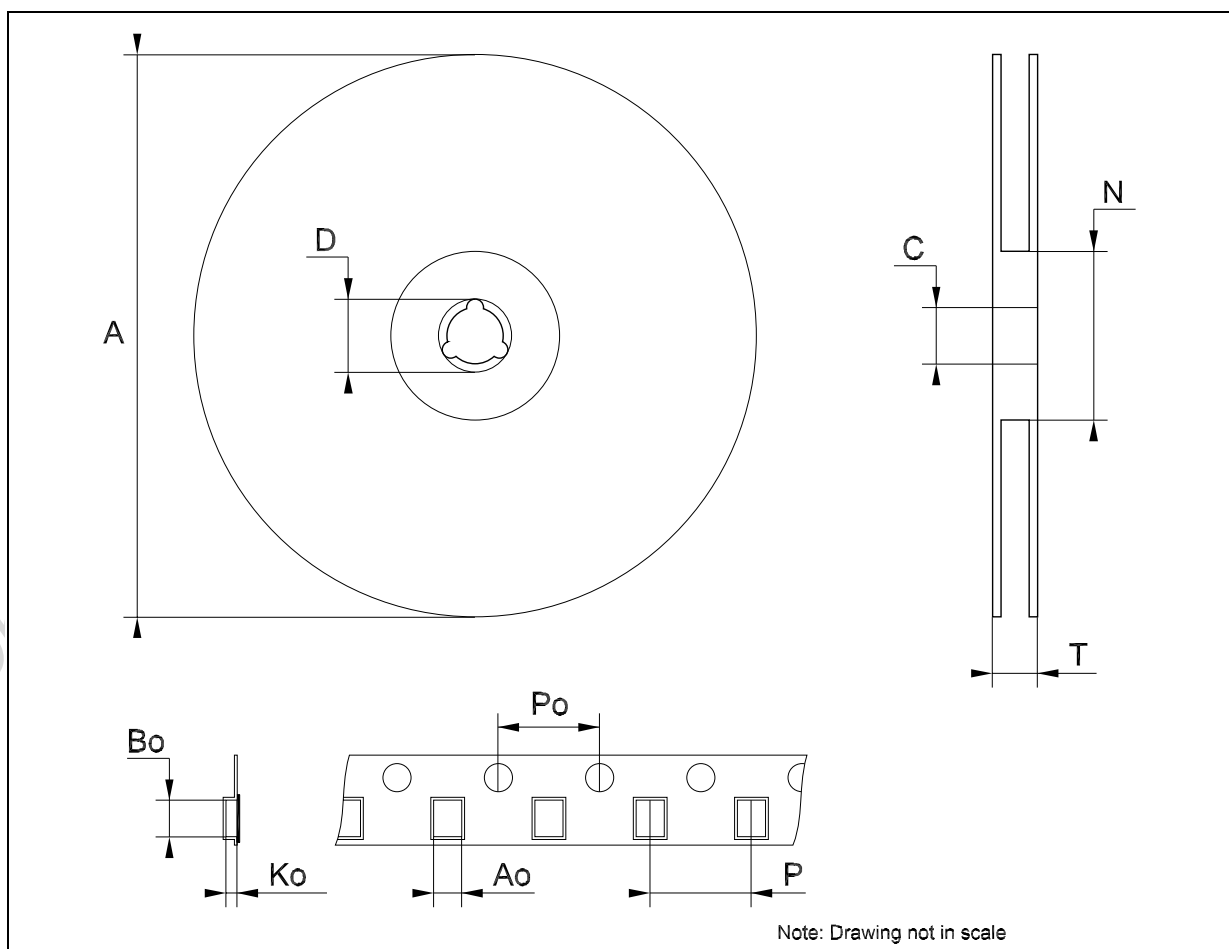

Information furnished is believed to be accurate and reliable. However, STMicroelectronics assumes no responsibility for the consequences of use of such information nor for any infringement of patents or other rights of third parties which may result from its use. No license is granted by implication or otherwise under any patent or patent rights of STMicroelectronics. Specifications mentioned in this publication are subject to change without notice. This publication supersedes and replaces all information previously supplied. STMicroelectronics products are not authorized for use as critical components in life support devices or systems without express written approval of STMicroelectronics.

The ST logo is a registered trademark of STMicroelectronics
All other names are the property of their respective owners

© 2004 STMicroelectronics - All Rights Reserved
STMicroelectronics GROUP OF COMPANIES

Australia - Belgium - Brazil - Canada - China - Czech Republic - Finland - France - Germany - Hong Kong - India - Israel - Italy - Japan -
Malaysia - Malta - Morocco - Singapore - Spain - Sweden - Switzerland - United Kingdom - United States.

<http://www.st.com>