



Chipsmall Limited consists of a professional team with an average of over 10 year of expertise in the distribution of electronic components. Based in Hongkong, we have already established firm and mutual-benefit business relationships with customers from,Europe,America and south Asia,supplying obsolete and hard-to-find components to meet their specific needs.

With the principle of “Quality Parts,Customers Priority,Honest Operation,and Considerate Service”,our business mainly focus on the distribution of electronic components. Line cards we deal with include Microchip,ALPS,ROHM,Xilinx,Pulse,ON,Everlight and Freescale. Main products comprise IC,Modules,Potentiometer,IC Socket,Relay,Connector.Our parts cover such applications as commercial,industrial, and automotives areas.

We are looking forward to setting up business relationship with you and hope to provide you with the best service and solution. Let us make a better world for our industry!



Contact us

Tel: +86-755-8981 8866 Fax: +86-755-8427 6832

Email & Skype: info@chipsmall.com Web: www.chipsmall.com

Address: A1208, Overseas Decoration Building, #122 Zhenhua RD., Futian, Shenzhen, China





Is Now Part of



ON Semiconductor®

To learn more about ON Semiconductor, please visit our website at
www.onsemi.com

ON Semiconductor and the ON Semiconductor logo are trademarks of Semiconductor Components Industries, LLC dba ON Semiconductor or its subsidiaries in the United States and/or other countries. ON Semiconductor owns the rights to a number of patents, trademarks, copyrights, trade secrets, and other intellectual property. A listing of ON Semiconductor's product/patent coverage may be accessed at www.onsemi.com/site/pdf/Patent-Marking.pdf. ON Semiconductor reserves the right to make changes without further notice to any products herein. ON Semiconductor makes no warranty, representation or guarantee regarding the suitability of its products for any particular purpose, nor does ON Semiconductor assume any liability arising out of the application or use of any product or circuit, and specifically disclaims any and all liability, including without limitation special, consequential or incidental damages. Buyer is responsible for its products and applications using ON Semiconductor products, including compliance with all laws, regulations and safety requirements or standards, regardless of any support or applications information provided by ON Semiconductor. "Typical" parameters which may be provided in ON Semiconductor data sheets and/or specifications can and do vary in different applications and actual performance may vary over time. All operating parameters, including "Typicals" must be validated for each customer application by customer's technical experts. ON Semiconductor does not convey any license under its patent rights nor the rights of others. ON Semiconductor products are not designed, intended, or authorized for use as a critical component in life support systems or any FDA Class 3 medical devices or medical devices with a same or similar classification in a foreign jurisdiction or any devices intended for implantation in the human body. Should Buyer purchase or use ON Semiconductor products for any such unintended or unauthorized application, Buyer shall indemnify and hold ON Semiconductor and its officers, employees, subsidiaries, affiliates, and distributors harmless against all claims, costs, damages, and expenses, and reasonable attorney fees arising out of, directly or indirectly, any claim of personal injury or death associated with such unintended or unauthorized use, even if such claim alleges that ON Semiconductor was negligent regarding the design or manufacture of the part. ON Semiconductor is an Equal Opportunity/Affirmative Action Employer. This literature is subject to all applicable copyright laws and is not for resale in any manner.



March 2015

74VHC14 Hex Schmitt Inverter

Features

- High Speed: $t_{PD} = 5.5 \text{ ns}$ (Typ.) at $V_{CC} = 5 \text{ V}$
- Low Power Dissipation: $I_{CC} = 2 \mu\text{A}$ (Max.) at $T_A = 25^\circ\text{C}$
- High Noise Immunity: $V_{NIH} = V_{NIL} = 28\% V_{CC}$ (Min.)
- Power down protection is provided on all inputs
- Low Noise: $V_{OLP} = 0.8 \text{ V}$ (Max.)
- Pin and Function Compatible with 74HC14

General Description

The VHC14 is an advanced high speed CMOS Hex Schmitt Inverter fabricated with silicon gate CMOS technology. It achieves the high speed operation similar to equivalent Bipolar Schottky TTL while maintaining the CMOS low power dissipation. Pin configuration and function are the same as the VHC04 but the inputs have hysteresis between the positive-going and negative-going input thresholds, which are capable of transforming slowly changing input signals into sharply defined, jitter-free output signals, thus providing greater noise margin than conventional inverters.

An input protection circuit ensures that 0 V to 7 V can be applied to the input pins without regard to the supply voltage. This device can be used to interface 5 V to 3 V systems and two supply systems such as battery back up. This circuit prevents device destruction due to mismatched supply and input voltages.

Ordering Information

| Part Number | Top Mark | Package | Packing Method |
|-------------|----------|-----------|----------------|
| 74VHC14M | 74VHC14 | SOIC 14L | Rail |
| 74VHC14MX | 74VHC14 | SOIC 14L | Tape and Reel |
| 74VHC14SJX | VHC14 | SOP 14L | Tape and Reel |
| 74VHC14MTC | V14 | TSSOP 14L | Rail |
| 74VHC14MTCX | V14 | TSSOP 14L | Tape and Reel |

Logic Symbol/s

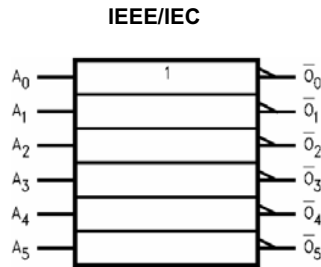

Connection Diagram/s

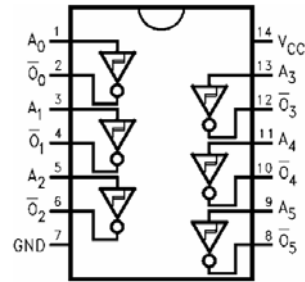

Pin Descriptions

| Pin Names | Description |
|------------------|-------------|
| A_n | Inputs |
| \overline{O}_n | Outputs |

Truth Table/s

| A | O |
|---|---|
| L | H |
| H | L |

Absolute Maximum Ratings⁽¹⁾

Stresses exceeding the absolute maximum ratings may damage the device. The device may not function or be operable above the recommended operating conditions and stressing the parts to these levels is not recommended. In addition, extended exposure to stresses above the recommended operating conditions may affect device reliability. The absolute maximum ratings are stress ratings only.

| Symbol | Parameter | Value | Unit |
|-----------|---|----------------------|--------------------|
| V_{CC} | Supply Voltage | -0.5 to +7.0 | V |
| V_{IN} | DC Input Voltage | -0.5 to +7.0 | V |
| V_{OUT} | DC Output Voltage | -0.5 to $V_{CC}+0.5$ | V |
| I_{IK} | Input Diode Current | -20 | mA |
| I_{OK} | Output Diode Current | ± 20 | mA |
| I_{OUT} | DC Output Current | ± 25 | mA |
| I_{CC} | DC V_{CC} / GND Current | ± 50 | mA |
| T_{STG} | Storage Temperature Range | -65 to +150 | $^{\circ}\text{C}$ |
| T_L | Lead Temperature (Soldering 10 seconds) | 260 | $^{\circ}\text{C}$ |

Note:

1. Absolute maximum ratings are values beyond which the device may be damaged or have its useful life impaired. The data book specifications should be met, without exception, to ensure that the system design is reliable over its power supply, temperature, and output/input loading variables. Fairchild does not recommend operation outside data-book specifications.

Recommended Operating Conditions⁽²⁾

The Recommended Operating Conditions table defines the conditions for actual device operation. Recommended operating conditions are specified to ensure optimal performance to the datasheet specifications. Fairchild does not recommend exceeding them or designing to absolute maximum ratings.

| Symbol | Parameter | Min. | Max. | Unit |
|------------------|-----------------------------|------|-----------------|------|
| V _{CC} | Supply Voltage | 2.0 | 5.5 | V |
| V _{IN} | Input Voltage | 0 | 5.5 | V |
| V _{OUT} | Output Voltage | 0 | V _{CC} | V |
| T _{OPR} | Operating Temperature Range | -40 | 85 | °C |

Note:

2. Unused inputs must be held HIGH or LOW. They may not float.

DC Electrical Characteristics

| Symbol | Parameter | V _{CC} | T _A = 25°C | | | T _A = -40 to 85°C | | Unit | Conditions | |
|-----------------|----------------------------|-----------------|-----------------------|------|------|------------------------------|------|------|---|-------------------------|
| | | | Min. | Typ. | Max. | Min. | Max. | | | |
| V _P | Positive Threshold Voltage | 3.0 | | | 2.20 | | 2.20 | V | | |
| | | 4.5 | | | 3.15 | | 3.15 | | | |
| | | 5.5 | | | 3.85 | | 3.85 | | | |
| V _N | Negative Threshold Voltage | 3.0 | 0.90 | | | 0.90 | | V | | |
| | | 4.5 | 1.35 | | | 1.35 | | | | |
| | | 5.5 | 1.65 | | | 1.65 | | | | |
| V _H | Hysteresis Voltage | 3.0 | 0.30 | | 1.20 | 0.30 | 1.20 | V | | |
| | | 4.5 | 0.40 | | 1.40 | 0.40 | 1.40 | | | |
| | | 5.5 | 0.50 | | 1.60 | 0.50 | 1.60 | | | |
| V _{OH} | HIGH Level Output Voltage | 2.0 | 1.9 | 2.0 | | 1.9 | | V | V _{IN} = V _{IL} I _{OH} = -50 μA | |
| | | 3.0 | 2.9 | 3.0 | | 2.9 | | | | |
| | | 4.5 | 4.4 | 4.5 | | 4.4 | | | | |
| | | 3.0 | 2.58 | | | 2.48 | | | | I _{OH} = -4 mA |
| | | 4.5 | 3.94 | | | 3.80 | | | | I _{OH} = -8 mA |
| V _{OL} | LOW Level Output Voltage | 2.0 | | 0.0 | 0.1 | | 0.1 | V | V _{IN} = V _{IH} I _{OL} = 50 μA | |
| | | 3.0 | | 0.0 | 0.1 | | 0.1 | | | |
| | | 4.5 | | 0.0 | 0.1 | | 0.1 | | | |
| | | 3.0 | | | 0.36 | | 0.44 | | | I _{OL} = 4 mA |
| | | 4.5 | | | 0.36 | | 0.44 | | | I _{OL} = 8 mA |
| I _{IN} | Input Leakage Current | 0 - 5.5 | | | ±0.1 | | ±1.0 | μA | V _{IN} = 5.5 V or GND | |
| I _{CC} | Quiescent Supply Current | 5.5 | | | 2.0 | | 20.0 | μA | V _{IN} = V _{CC} or GND | |

Noise Characteristics⁽²⁾

| Symbol | Parameter | V _{CC} | T _A = 25°C | | Unit | Conditions |
|------------------|--|-----------------|-----------------------|------|------|------------------------|
| | | | Typ. | Max. | | |
| V _{OLP} | Quiet Output Maximum Dynamic V _{OL} | 5.0 | 0.4 | 0.8 | V | C _L = 50 pF |
| V _{OLV} | Quiet Output Minimum Dynamic V _{OL} | 5.0 | -0.4 | 0.8 | V | C _L = 50 pF |
| V _{IHD} | Minimum HIGH Level Dynamic Input Voltage | 5.0 | | 3.5 | V | C _L = 50 pF |
| V _{ILD} | Maximum LOW Level Dynamic Input Voltage | 5.0 | | 1.5 | V | C _L = 50 pF |

Note:

2. Parameter guaranteed by design.

AC Electrical Characteristics

| Symbol | Parameter | V _{CC} | T _A = 25°C | | | T _A = -40 to 85°C | | Unit | Conditions |
|--------------------------------------|-------------------------------|-----------------|-----------------------|------|------|------------------------------|------|------|------------------------|
| | | | Min. | Typ. | Max. | Min. | Max. | | |
| t _{PLH} t _{PHL} | Propagation Delay Time | 3.3 ± 0.3 | | 8.3 | 12.8 | 1.0 | 15.0 | ns | C _L = 15 pF |
| | | | | 10.8 | 16.3 | 1.0 | 18.5 | | C _L = 50 pF |
| | | 5.0 ± 0.5 | | 5.5 | 8.6 | 1.0 | 10.0 | | C _L = 15 pF |
| | | | | 7.0 | 10.6 | 1.0 | 12.0 | | C _L = 50 pF |
| C _{IN} | Input Capacitance | | | 4 | 10 | | 10 | pF | V _{CC} = Open |
| C _{PD} | Power Dissipation Capacitance | | | 21 | | | | pF | ⁽³⁾ |

Note:

3. C_{PD} is defined as the value of the internal equivalent capacitance which is calculated from the opening current consumption without load.

Average operating current can be obtained by the equation: I_{CC} (Opr) = C_{PD} * V_{CC} * f_{IN} + I_{CC} /6 (per Gate)

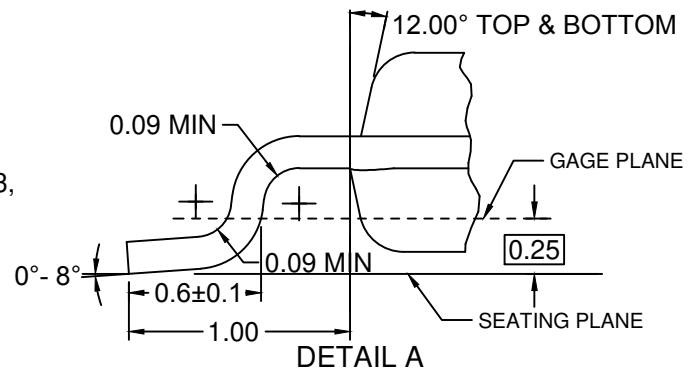
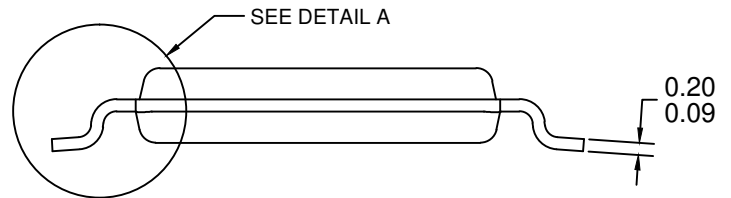
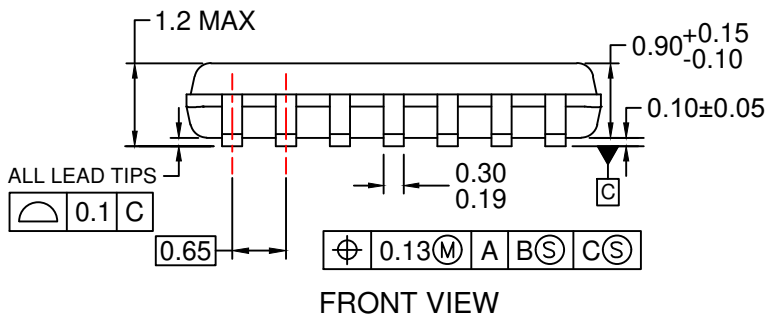
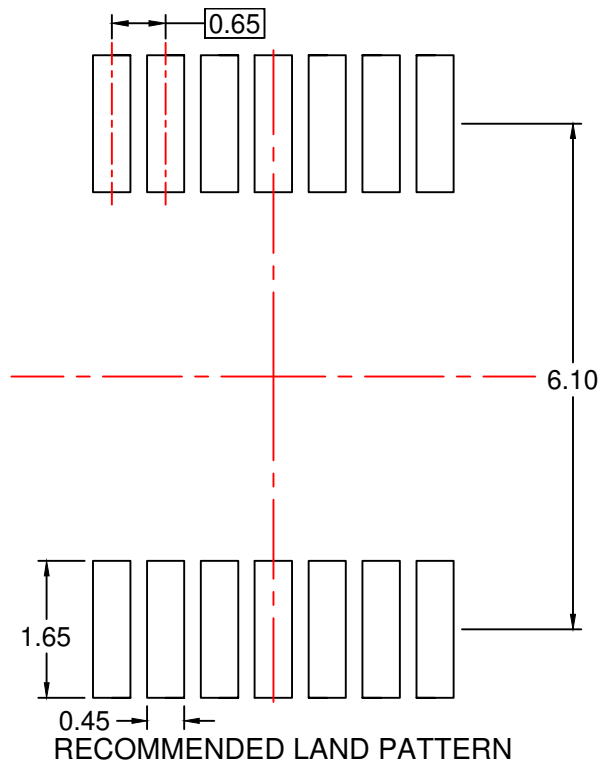
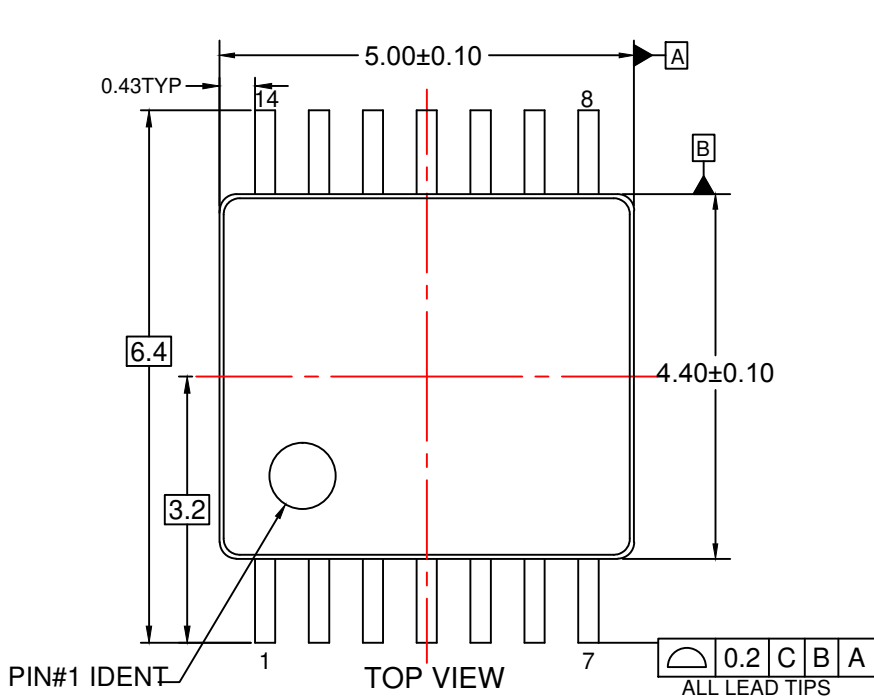

NOTES:

- A. CONFORMS TO JEDEC REGISTRATION MO-153, VARIATION AB, REF NOTE 6
- B. DIMENSIONS ARE IN MILLIMETERS.
- C. DIMENSIONS ARE EXCLUSIVE OF BURRS, MOLD FLASH, AND TIE BAR EXTRUSIONS
- D. DIMENSIONING AND TOLERANCES PER ANSI Y14.5M, 2009.
- E. LANDPATTERN STANDARD: SOP65P640X110-14M.
- F. DRAWING FILE NAME: MKT-MTC14rev7.



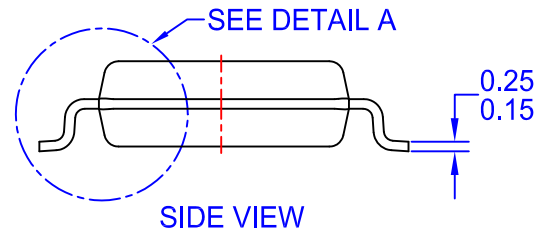
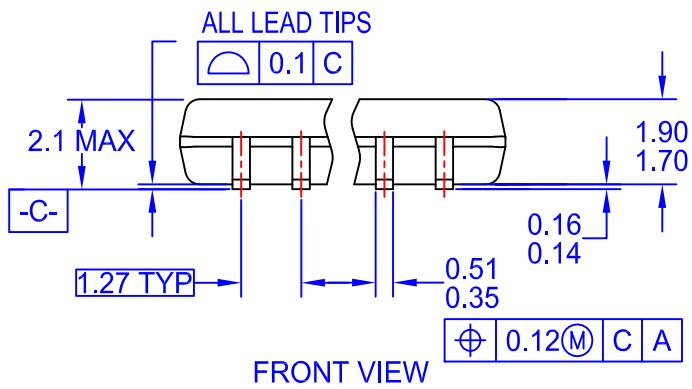
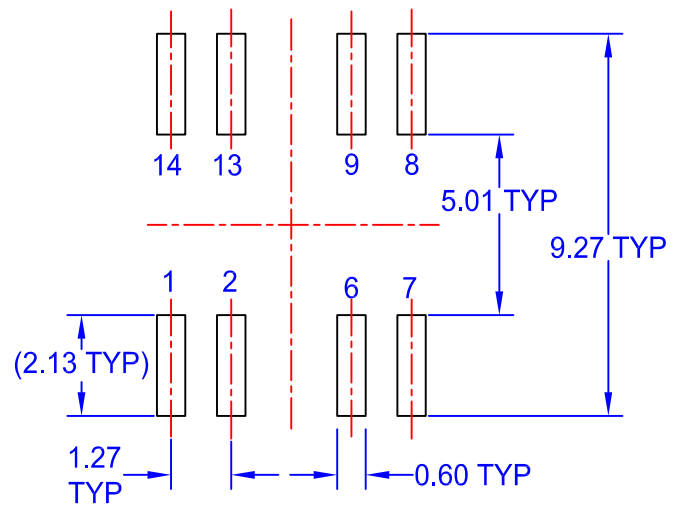
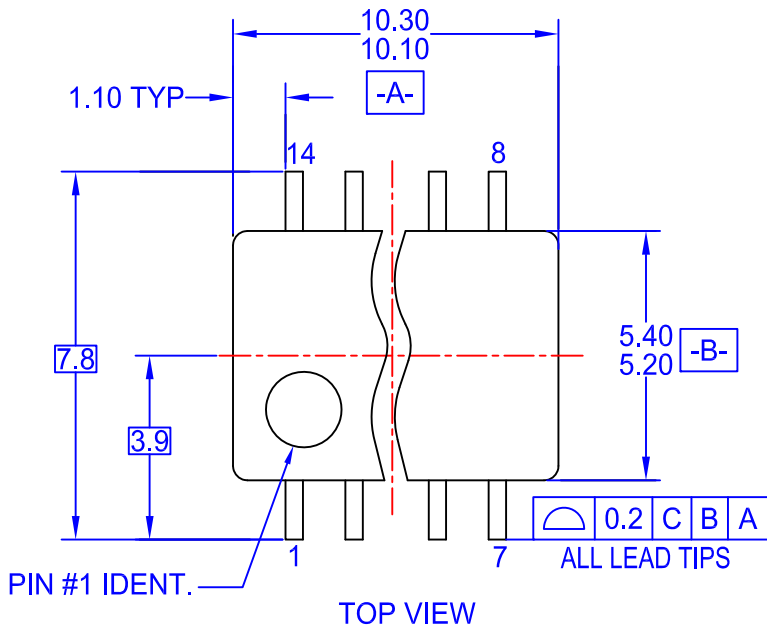

- NOTES:
- A. CONFORMS TO EIAJ EDR-7320 REGISTRATION, ESTABLISHED IN DECEMBER, 1998.
 - B. DIMENSIONS ARE IN MILLIMETERS.
 - C. DIMENSIONS ARE EXCLUSIVE OF BURRS, MOLD FLASH, AND TIE BAR EXTRUSIONS.
 - D. DRAWING FILENAME: MKT-M14Drev4.

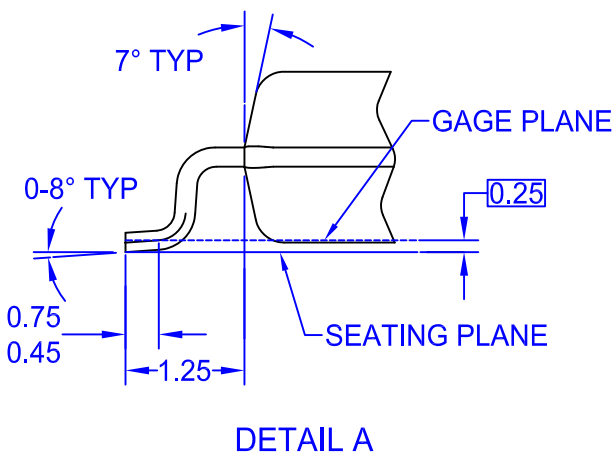

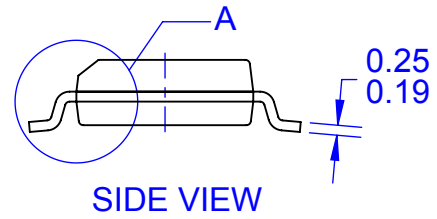
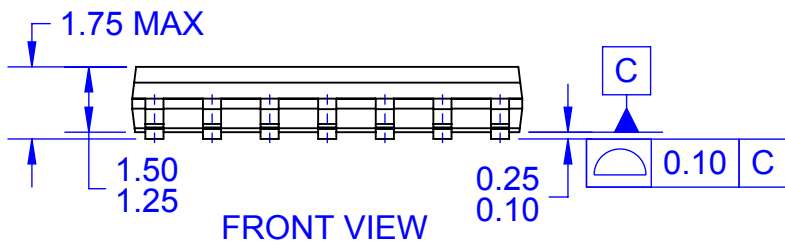
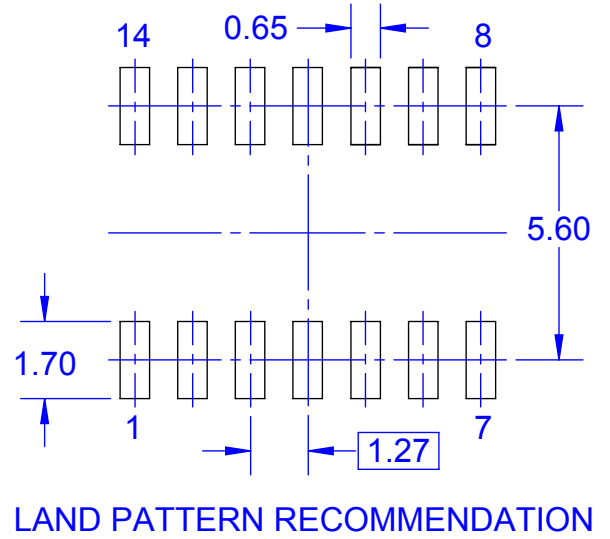
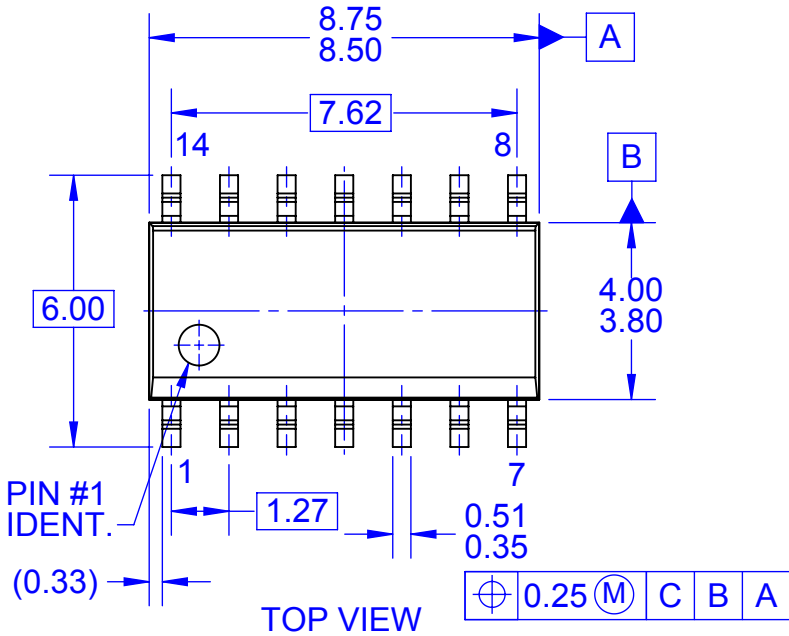

NOTES:

- A. CONFORMS TO JEDEC MS-012, VARIATION AB, ISSUE C
- B. ALL DIMENSIONS ARE IN MILLIMETERS
- C. DIMENSIONS DO NOT INCLUDE MOLD FLASH OR BURRS
- D. LAND PATTERN STANDARD: SOIC127P600X145-14M
- E. CONFORMS TO ASME Y14.5M, 2009
- D. DRAWING FILENAME: MKT-M14Arev14

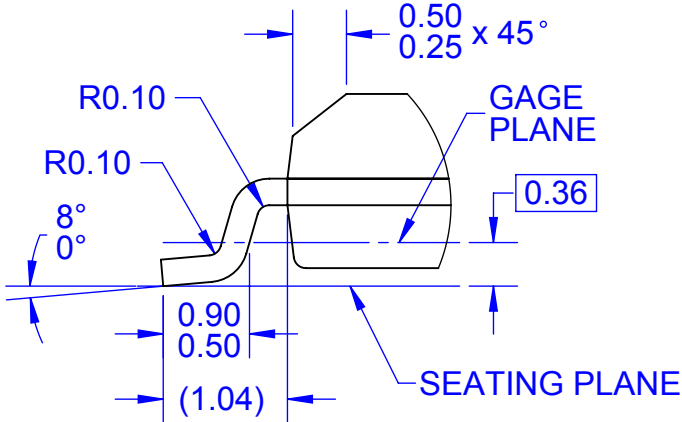

ON Semiconductor and  are trademarks of Semiconductor Components Industries, LLC dba ON Semiconductor or its subsidiaries in the United States and/or other countries. ON Semiconductor owns the rights to a number of patents, trademarks, copyrights, trade secrets, and other intellectual property. A listing of ON Semiconductor's product/patent coverage may be accessed at www.onsemi.com/site/pdf/Patent-Marking.pdf. ON Semiconductor reserves the right to make changes without further notice to any products herein. ON Semiconductor makes no warranty, representation or guarantee regarding the suitability of its products for any particular purpose, nor does ON Semiconductor assume any liability arising out of the application or use of any product or circuit, and specifically disclaims any and all liability, including without limitation special, consequential or incidental damages. Buyer is responsible for its products and applications using ON Semiconductor products, including compliance with all laws, regulations and safety requirements or standards, regardless of any support or applications information provided by ON Semiconductor. "Typical" parameters which may be provided in ON Semiconductor data sheets and/or specifications can and do vary in different applications and actual performance may vary over time. All operating parameters, including "Typicals" must be validated for each customer application by customer's technical experts. ON Semiconductor does not convey any license under its patent rights nor the rights of others. ON Semiconductor products are not designed, intended, or authorized for use as a critical component in life support systems or any FDA Class 3 medical devices or medical devices with a same or similar classification in a foreign jurisdiction or any devices intended for implantation in the human body. Should Buyer purchase or use ON Semiconductor products for any such unintended or unauthorized application, Buyer shall indemnify and hold ON Semiconductor and its officers, employees, subsidiaries, affiliates, and distributors harmless against all claims, costs, damages, and expenses, and reasonable attorney fees arising out of, directly or indirectly, any claim of personal injury or death associated with such unintended or unauthorized use, even if such claim alleges that ON Semiconductor was negligent regarding the design or manufacture of the part. ON Semiconductor is an Equal Opportunity/Affirmative Action Employer. This literature is subject to all applicable copyright laws and is not for resale in any manner.

PUBLICATION ORDERING INFORMATION

LITERATURE FULFILLMENT:

Literature Distribution Center for ON Semiconductor
19521 E. 32nd Pkwy, Aurora, Colorado 80011 USA
Phone: 303-675-2175 or 800-344-3860 Toll Free USA/Canada
Fax: 303-675-2176 or 800-344-3867 Toll Free USA/Canada
Email: orderlit@onsemi.com

N. American Technical Support: 800-282-9855 Toll Free
USA/Canada
Europe, Middle East and Africa Technical Support:
Phone: 421 33 790 2910
Japan Customer Focus Center
Phone: 81-3-5817-1050

ON Semiconductor Website: www.onsemi.com
Order Literature: <http://www.onsemi.com/orderlit>
For additional information, please contact your local
Sales Representative