



Chipsmall Limited consists of a professional team with an average of over 10 year of expertise in the distribution of electronic components. Based in Hongkong, we have already established firm and mutual-benefit business relationships with customers from,Europe,America and south Asia,supplying obsolete and hard-to-find components to meet their specific needs.

With the principle of “Quality Parts,Customers Priority,Honest Operation,and Considerate Service”,our business mainly focus on the distribution of electronic components. Line cards we deal with include Microchip,ALPS,ROHM,Xilinx,Pulse,ON,Everlight and Freescale. Main products comprise IC,Modules,Potentiometer,IC Socket,Relay,Connector.Our parts cover such applications as commercial,industrial, and automotives areas.

We are looking forward to setting up business relationship with you and hope to provide you with the best service and solution. Let us make a better world for our industry!



Contact us

Tel: +86-755-8981 8866 Fax: +86-755-8427 6832

Email & Skype: info@chipsmall.com Web: www.chipsmall.com

Address: A1208, Overseas Decoration Building, #122 Zhenhua RD., Futian, Shenzhen, China



Product Information Pack

NO2 3E 50 Gas Sensor Module (Nitrogen Dioxide)

CONTENTS

Product Data Sheet

Product Specification	2
Poisoning and Cross Sensitivities	3

Operating Instructions

Introduction	4
Electrostatic Discharge Guidelines	5
Mounting Orientation	5
Connection and Wiring	5
Error Conditions	6
Calibration Guidelines	6
Handling and Storage	8

Scope and Purpose of Document

The purpose of this document is to present the performance specification and operating instructions of the NO2 3E 50 Gas Sensor Module. All information required for the correct use of the Gas Sensor Module is included in this document.

For Product Safety Datasheets (PSDS), REACH and RoHS information, please visit www.citytech.com.

The data provided in this document are valid at 20°C, 50% RH and 1013 mBar. Output signal can drift below the lower limit over time.

Product Data Sheet

- Key Features & Benefits:**
- Industry standard 4-20 mA output
 - 40-200 mV option

Technical Specifications

MEASUREMENT

Target Gas	Nitrogen Dioxide (NO ₂)
Operating Principle	3-electrode electrochemical
Measurement Range	0.3 - 50 ppm NO ₂
Filter	None
Output	4-20 mA, 2 wire loop powered 40-200 mV
Response Time	
T ₅₀	<10 Seconds
T ₉₀	<30 Seconds
Resolution	0.01 mA
Linearity	<5% of full scale

ELECTRICAL

Power Supply Required	10 - 30 VDC single-ended
Maximum Loop Resistance	700 Ω
Calibration	Via PCB mounted button and potentiometer

MECHANICAL

Mounting	Via 3mm PCB mounting holes
Weight	<13 g
Sensor Housing Material	ABS

ENVIRONMENTAL

Operating Temperature Range	-20°C to +40°C
Recommended Storage Temp	4°C to 10°C
Operating Humidity Range	15% to 90% rH non-condensing

LIFETIME

Long Term Output Drift	<5% per month
Expected Operating Life	2 years in air

Specifications are valid at 20°C,
50% RH and 1013 mBar.

Product Dimensions

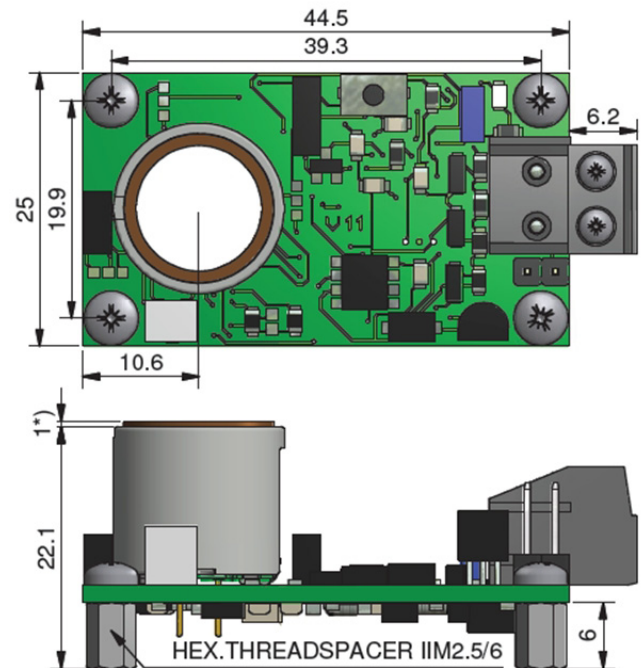

All dimensions in mm
All tolerances ±0.15 mm unless otherwise stated

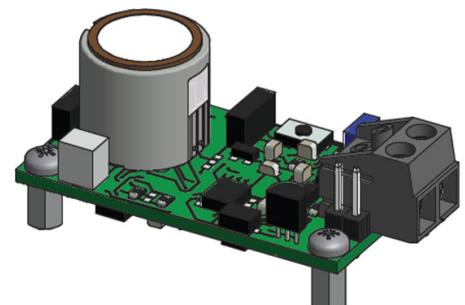

Product Data Sheet

Poisoning

These sensors are designed for operation in a wide range of environments and harsh conditions. However, it is important that exposure to high concentrations of solvent vapours is avoided, both during storage, fitting into instruments, and operation.

When using Gas Sensor Modules with printed circuit boards (PCBs), degreasing agents should be used before the module is fitted. Do not glue directly on or near the modules as the solvent may cause crazing of the plastic.

Cross Sensitivity Table

Whilst these sensors are designed to be highly specific to the gas they are intended to measure, they will still respond to some degree to various other gases. The table below is not exclusive and other gases not included in the table may still cause a sensor to react.

IMPORTANT NOTE : The cross sensitivity data shown below does not form part of the product specification and is supplied for guidance only. Values quoted are based on tests conducted on a small number of sensors and any batch may show significant variation. For the most accurate measurements, the Gas Sensor Module should be calibrated using the gas under investigation.

Gas	Concentration Used	Reading (ppm NO ₂)
Alcohols	1000 ppm	0
Carbon Dioxide, CO ₂	5000 ppm	0
Chlorine, Cl ₂	1 ppm	1
Nitric Oxide, NO	100 ppm	0.4
Sulfur Dioxide, SO ₂	20 ppm	-5
Hydrogen, H ₂	3000 ppm	0

Product Operating Instructions

Introduction

The Gas Sensor Module provides easy to use connectivity and output, compactness, and ease of calibration for most life safety and environmental monitoring applications. It provides a calibrated 4-20 mA output as well as a 40-200 mV signal output.

Features:

- Fully calibrated 4-20 mA (and 40-200 mV) output for each target gas;
- Linear output across detection range;
- Power in / output out, no setup required;
- Board allows user to calibrate gas sensor against target gas;
- Equipped with four mounting holes for prototyping.

All Gas Sensor Modules can be mounted via four 3 mm mounting holes in the PCB.

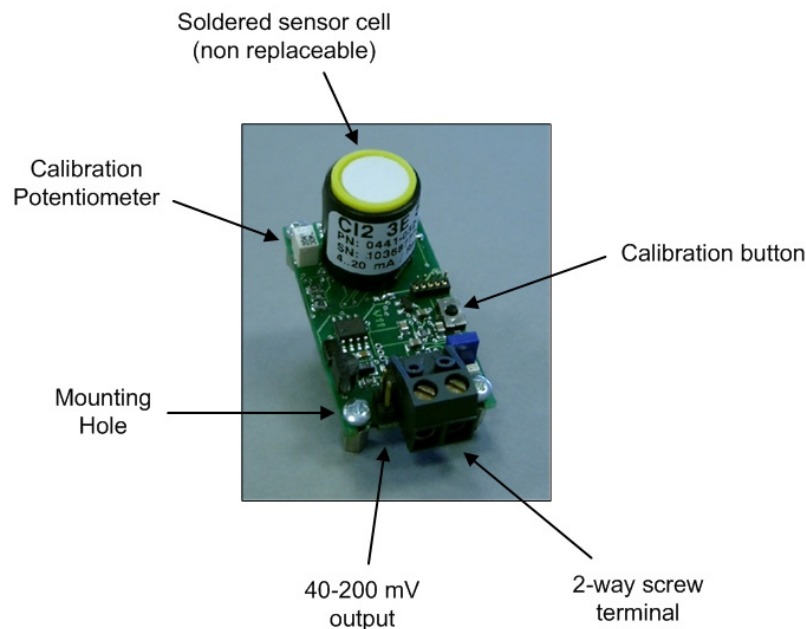

Gas Sensor Module Features

The Gas Sensor Module is shipped calibrated to a 4-20 mA output. There are two options for recalibration:

- by use of the PCB mounted calibration button (for zero and span calibration);
- by use of the potentiometer (for span calibration).

The PCB incorporates on-board temperature compensation and allows the use of an optional external temperature sensor.

Product Operating Instructions

Electrostatic Discharge Guidelines

This component is susceptible to Electrostatic Discharge (ESD) when being installed or adjusted. To prevent ESD related damage during installation, the following guidelines should be considered:

- Ensure all power supplies are turned off;
- Wear an ESD strap connected to ground or discharge yourself by touching a metal part of the equipment into which the module is being installed;
- Ensure that any tools are discharged by contacting them against a metal part of the equipment into which the Gas Sensing Module is being installed;
- When adjusting potentiometers, with power applied, use an appropriate potentiometer adjustment tool or a small insulated screwdriver.

Mounting Orientation

Gas Sensor Modules should be installed with the sensor gas inlet side pointing downwards. The minimum requirement is to install the sensor with the sensor's gas inlet in a horizontal direction. It is not advisable to install the sensor with the gas inlet side permanently pointing upwards.

Connection and Wiring

The Gas Sensor Module is designed for standard two-wire operation, where the 4-20 mA output is supplied via the same wire pair as the power supply. The external circuit loop is connected to the transmitter PCB via the screw terminal connector - see below. The connector can be used in two orientations - vertically or horizontally.

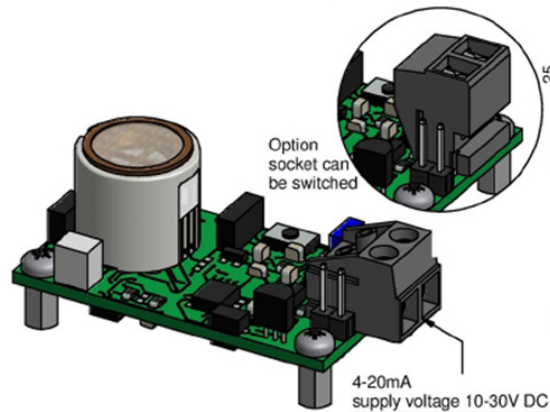

The Gas Sensor Module offers reverse polarity protection, so the power supply can be connected in either direction.

The sensor only requires a few seconds to settle after power is applied. In addition to the 4-20 mA signal in the 2-wire loop, a 40-200 mV voltage output is also available.

Operational status can be retrieved by pressing and holding the calibration button for between 0.5 - 3.0 seconds. The blinking pattern of the LED shows the calibration status, as follows.

- 1 blink : Factory settings (as delivered)
- 2 blink : Individual settings (recalibrated)
- 3 blink : Factory settings after reset

Product Operating Instructions

Error Conditions

In normal use, the Gas Sensor Module output will remain within the range of 4 mA (for zero gas) and 20 mA (for span gas). An output of 0 mA represents a fault on the circuit board. Other error conditions are signalled by the module output going to 21 mA.

Error conditions recognised by the board are as follows:

- Output dropping below 3.8 mA;
- Output rising above 20.5 mA;
- The board is used at temperatures more than 5°C outside of its temperature specification.

Calibration Guidelines

The Gas Sensor Module is calibrated before shipping to the customer. It provides a stable signal over its standard life and for many applications, only requires occasional recalibration. The time interval required between initial calibration and subsequent recalibrations depends on various factors. In strenuous applications involving extremes of operation, or for sensors used in safety applications, frequent calibration may be required.

Calibration Period

Calibration is required if the deviation of the measured value is outside the limits required by the application.

Calibration Gas Concentration

For maximum accuracy, the Gas Sensor Module should be calibrated using a gas concentration in the range where most measurements are to be made. Where this is not possible, a concentration towards the top of the measurement range should be chosen. Calibration gases exceeding the measurement range must not be used as this may not provide an accurate calibration.

Electrochemical gas sensors need a certain amount of oxygen to function. Generally, a few thousand ppm oxygen is sufficient. However, as calibration only involves a short exposure to gas, the calibration gas need not contain oxygen - sufficient is supplied from the ambient air for a limited time. In most cases, a five minute exposure time is sufficient to achieve a stable calibration signal. However the sensor should not be completely potted with resin or totally immersed in an anaerobic gas mixture for long periods as this can affect the sensor's performance.

Calibrating to Cross Sensitive Gases

Electrochemical sensors are cross sensitive to certain non-target gases. Cross sensitivity data is only approximate and cross sensitivities will vary between sensors and sensor batches. Calibrating Gas Sensor Modules to non-target gas will result in measurement errors and is not advised.

Product Operating Instructions

Recommended Gas Flow Rates

A minimum flow rate is required to ensure accurate calibration. The minimum flow rate is dependant on the gas type.

Gas Type	Minimum Flow Rate (ml/min)
Ammonia, NH ₃	250
Carbon Monoxide, CO	150
Hydrogen, H ₂	150
Hydrogen Sulfide, H ₂ S	250
Nitrogen Dioxide, NO ₂	250
Ozone, O ₃	250

These flow rates are based on gas delivery apparatus used by City Technology. Other designs of gas delivery may have an influence on the flow rates required.

User Calibration Procedure

Note that warranty on calibration is lost once a recalibration is performed.

Zero Reading Calibration

- Connect and apply power to the Gas Sensor Module.
- Allow the sensor to stabilize for a minimum of 5 minutes in clean air.
- Once the output signal is stable, press and hold the calibration button for between 6 and 12 seconds.
- The LED acknowledges calibration by blinking 6 times.

Span Calibration

Via calibration button

- Apply calibration gas to the sensor at the appropriate flow rate for a minimum of 5 minutes.
- Once output signal is stable, press and hold the calibration button for between 12 and 60 seconds.
- The LED acknowledges calibration by blinking 8 times.
- Remove gas and reapply clean air.

Via potentiometer

- Apply calibration gas to the sensor at the appropriate flow rate for a minimum of 5 minutes.
- Once output signal is stable, set the output to the appropriate value by adjusting the potentiometer.
- Remove gas and reapply clean air.

Factory Reset

- Press and hold the calibration button for between 3 and 6 seconds.
- The LED acknowledges the factory reset by blinking 4 times.

Handling and Storage

Gas Sensor Modules are relatively insensitive to mishandling and following the simple guidelines given below should ensure correct operation.

- Gas Sensor Modules must not be exposed to temperatures outside the range -55°C to +60°C. Modules should be stored in their original sealed packaging within the temperature range of +4°C to 10°C with the sensor membrane faced downwards.
- Gas Sensor Modules should not be stored, assembled or used in areas containing solvent vapours. Exposure to solvents will result in performance degradation and premature sensor failure.
- Exposure of modules to alcohol containing antiseptic products such as wipes and sanitizing gels should be avoided. Modules can respond to the alcohol based solvents and generate an output, which could manifest itself as an exaggerated baseline signal or prolonged recovery time.
- Gas Sensor Modules must not be subjected to any pressure when handling or clamping.
- To avoid damage to the sensing face of the sensors, Gas Sensor Modules must not be stacked on top of each other.
- At the end of its life, the product should be disposed of in accordance with local regulations. The hazardous waste disposal regulations depend on geographic location, and local regulations should be checked before discarding sensors.

SAFETY NOTE

This module is designed to be used in safety critical applications. To ensure that the Gas Sensor Module and/or instrument in which it is used are operating properly, it is a requirement that the function of the device is confirmed by exposure to target gas (bump check) before each use of the module and/or instrument. Failure to carry out such tests may jeopardize the safety of people and property.

Every effort has been made to ensure the accuracy of this document at the time of printing. In accordance with the company's policy of continued product improvement, Life Safety Germany GmbH reserves the right to make product changes without notice. The products are always subject to a programme of improvement and testing which may result in some changes in the characteristics quoted. As the products may be used by the client in circumstances beyond the knowledge and control of Life Safety Germany GmbH, we cannot give any warranty as to the relevance of these particulars to an application. Life Safety Germany GmbH warrants goods of its manufacture as being free of defective materials and faulty workmanship. Life Safety Germany GmbH's standard product warranty applies unless agreed to otherwise by Life Safety Germany GmbH in writing; please refer to your order acknowledgement or consult your local sales office for specific warranty details. If warranted goods are returned during the period of coverage, Life Safety Germany GmbH will repair or replace, at its option, without charge those items it finds defective. The foregoing is buyer's sole remedy and is in lieu of all other warranties, expressed or implied, including those of merchantability and fitness for a particular purpose. In no event shall Life Safety Germany GmbH be liable for consequential, special, or indirect damages. It is the clients' responsibility to carry out the necessary tests to determine the usefulness of the products and to ensure their safety of operation in a particular application. While we provide application assistance personally, through our literature and our web site, it is up to the customer to determine the suitability of the product in the application.