



Chipsmall Limited consists of a professional team with an average of over 10 year of expertise in the distribution of electronic components. Based in Hongkong, we have already established firm and mutual-benefit business relationships with customers from,Europe,America and south Asia,supplying obsolete and hard-to-find components to meet their specific needs.

With the principle of “Quality Parts,Customers Priority,Honest Operation,and Considerate Service”,our business mainly focus on the distribution of electronic components. Line cards we deal with include Microchip,ALPS,ROHM,Xilinx,Pulse,ON,Everlight and Freescale. Main products comprise IC,Modules,Potentiometer,IC Socket,Relay,Connector.Our parts cover such applications as commercial,industrial, and automotives areas.

We are looking forward to setting up business relationship with you and hope to provide you with the best service and solution. Let us make a better world for our industry!



Contact us

Tel: +86-755-8981 8866 Fax: +86-755-8427 6832

Email & Skype: info@chipsmall.com Web: www.chipsmall.com

Address: A1208, Overseas Decoration Building, #122 Zhenhua RD., Futian, Shenzhen, China





7514B/7511G Series Bright★ Pipes™ Optical Lightpipes
DESCRIPTION AND FEATURES

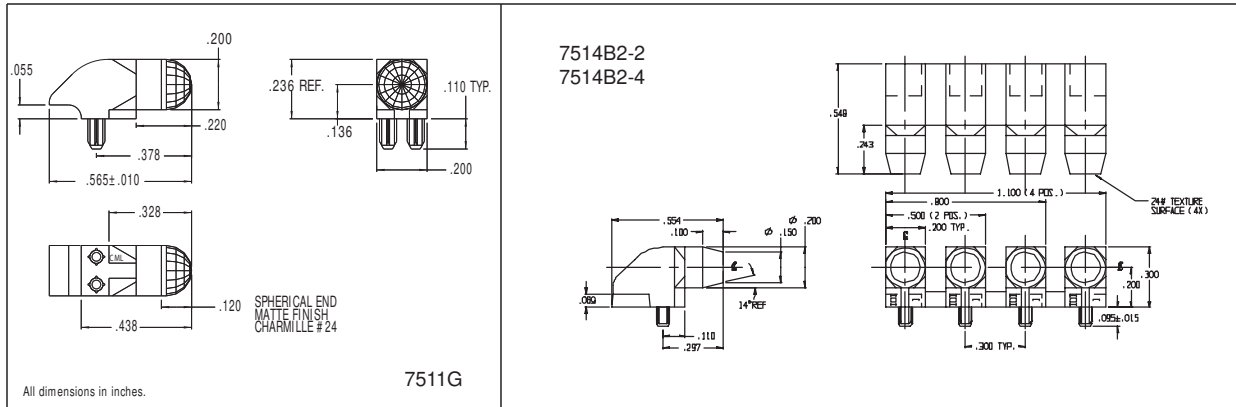

- Precision engineered with **ray tracing** for bright, optically precise even indication and attractive appearance.
- ESD protection from circuitry for exceptional reliability.
- High contrast and wide viewing angle for greater visibility.
- Available in a variety of colors for added contrast and aesthetics.
- Parts inserted after reflow to permit LED pad inspection before assembly.
- Compliance to UL94V-0
- Low profile for height constrained applications.
- Large lens provides high visibility.
- 7511H2 designed for use with 7012X SMT LED.

MODEL	OUTPUT COLOR
7511G2	DIFFUSED TRANSLUCENT
7511G1	CLEAR RED TINT
7511G5	CLEAR GREEN TINT
7511G7	CLEAR YELLOW

Mounting hole pattern on page 1-X4.