



Chipsmall Limited consists of a professional team with an average of over 10 year of expertise in the distribution of electronic components. Based in Hongkong, we have already established firm and mutual-benefit business relationships with customers from,Europe,America and south Asia,supplying obsolete and hard-to-find components to meet their specific needs.

With the principle of “Quality Parts,Customers Priority,Honest Operation,and Considerate Service”,our business mainly focus on the distribution of electronic components. Line cards we deal with include Microchip,ALPS,ROHM,Xilinx,Pulse,ON,Everlight and Freescale. Main products comprise IC,Modules,Potentiometer,IC Socket,Relay,Connector.Our parts cover such applications as commercial,industrial, and automotives areas.

We are looking forward to setting up business relationship with you and hope to provide you with the best service and solution. Let us make a better world for our industry!



Contact us

Tel: +86-755-8981 8866 Fax: +86-755-8427 6832

Email & Skype: info@chipsmall.com Web: www.chipsmall.com

Address: A1208, Overseas Decoration Building, #122 Zhenhua RD., Futian, Shenzhen, China



THIS SPECIFICATION SHEET FORMS A PART OF THE LATEST ISSUE OF RAYCHEM SPECIFICATION 1200.

CONSTRUCTION DETAILS

DIMENSIONS ARE NOMINAL VALUES IN INCHES UNLESS OTHERWISE DESIGNATED.

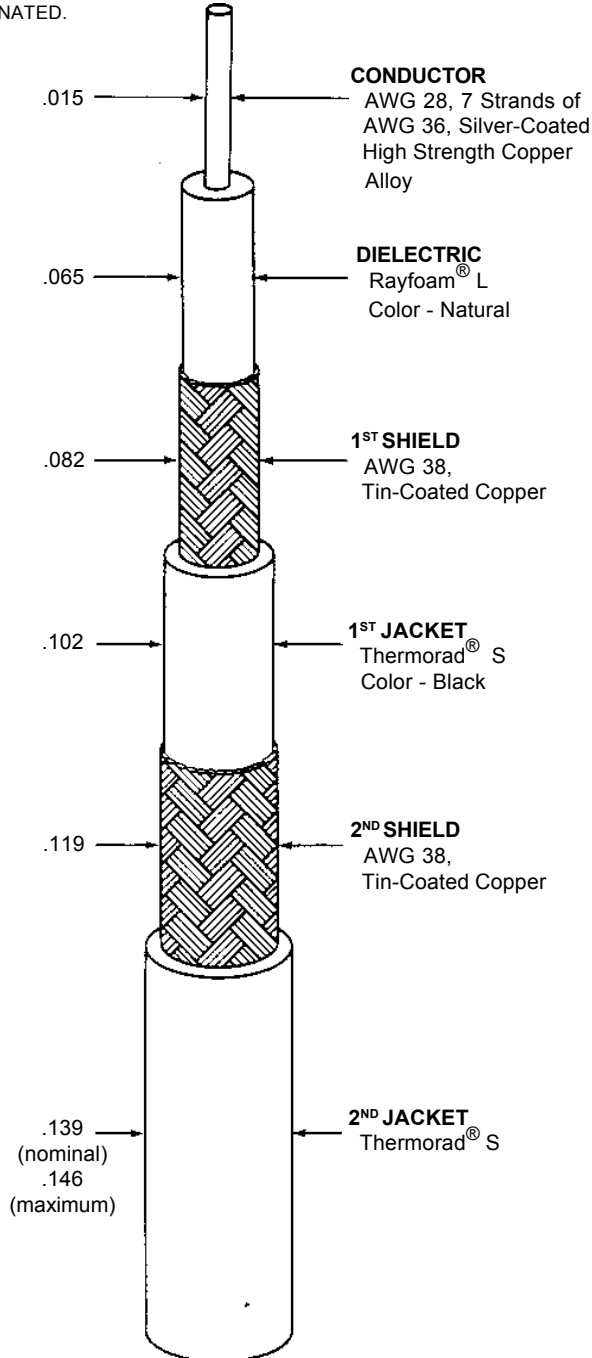

ELECTRICAL CHARACTERISTICS

CHARACTERISTIC IMPEDANCE	75 ± 3 ohms, Method B
CAPACITANCE	17.8 pF/ft. (nominal) at 1 kHz 19.0 pF/ft. (maximum) at 1 kHz
VELOCITY OF PROPAGATION	76% (nominal)

ADDITIONAL REQUIREMENTS

ELECTRICAL

CONDUCTOR RESISTANCE	74.0 ohms/1000 ft. (nominal)
INSULATION RESISTANCE (CONDUCTOR TO SHIELD)	10,000 megohms (minimum) for 1000 ft.
JACKET FLAWS	
SPARK TEST	1.0 kV (rms)
IMPULSE TEST	6.0 kV, (peak)
VOLTAGE WITHSTAND (DIELECTRIC)	
CONDUCTOR TO SHIELD	1000 volts (rms) (minimum)
SHIELD TO SHIELD	500 volts (rms) (minimum)

ENVIRONMENTAL

FLAMMABILITY	Method C
HEAT SHOCK	225°C
LOW TEMPERATURE- COLD BEND	-55°C/3.75 inch mandrel
VOLTAGE WITHSTAND (POST ENVIRONMENTAL)	1000 volts (rms), 1 minute

PHYSICAL

INSULATION (DIELECTRIC)	
ELONGATION	50% (minimum)
TENSILE STRENGTH	1000 lbf/in ² (minimum)
JACKET (EACH)	
ELONGATION	200% (minimum)
TENSILE STRENGTH	2000 lbf/in ² (minimum)
JACKET THICKNESS (EACH)	.010 inch (nominal)
SHIELD COVERAGE (EACH)	90% (minimum)

CABLE IDENTIFICATION Mark outer jacket in contrasting color at 12 inch (nominal) intervals: "7528A5314 - 06090"

WEIGHT 15.3 lbs/1000 ft. (nominal)

Outer jacket color will be black (designated by a "-0" appended to the part number, e.g. 7528A5314-0) unless otherwise specified.

Designate outer jacket color with a dash number in accordance with MIL-STD-681. Other codes and suffixes may be added to the part number, as necessary, to capture any additional requirements imposed by the purchase order.

Users should evaluate the suitability of this product for their application. Specifications are subject to change without notice. Tyco Electronics also reserves the right to make changes in materials or processing, which do not affect compliance with any specification, without notification to Buyer.