



Chipsmall Limited consists of a professional team with an average of over 10 year of expertise in the distribution of electronic components. Based in Hongkong, we have already established firm and mutual-benefit business relationships with customers from,Europe,America and south Asia,supplying obsolete and hard-to-find components to meet their specific needs.

With the principle of "Quality Parts,Customers Priority,Honest Operation,and Considerate Service",our business mainly focus on the distribution of electronic components. Line cards we deal with include Microchip,ALPS,ROHM,Xilinx,Pulse,ON,Everlight and Freescale. Main products comprise IC,Modules,Potentiometer,IC Socket,Relay,Connector.Our parts cover such applications as commercial,industrial, and automotives areas.

We are looking forward to setting up business relationship with you and hope to provide you with the best service and solution. Let us make a better world for our industry!



Contact us

Tel: +86-755-8981 8866 Fax: +86-755-8427 6832

Email & Skype: info@chipsmall.com Web: www.chipsmall.com

Address: A1208, Overseas Decoration Building, #122 Zhenhua RD., Futian, Shenzhen, China



PROPER USE GUIDELINES

Cumulative Trauma Disorders can result from the prolonged use of manually powered hand tools. AMP hand tools are intended for occasional use and low volume applications. AMP offers a wide selection of powered application equipment for extended-use, production operations.

CONNECTOR-SPECIFIC KIT 768341-1



TYPICAL APPLICATIONS

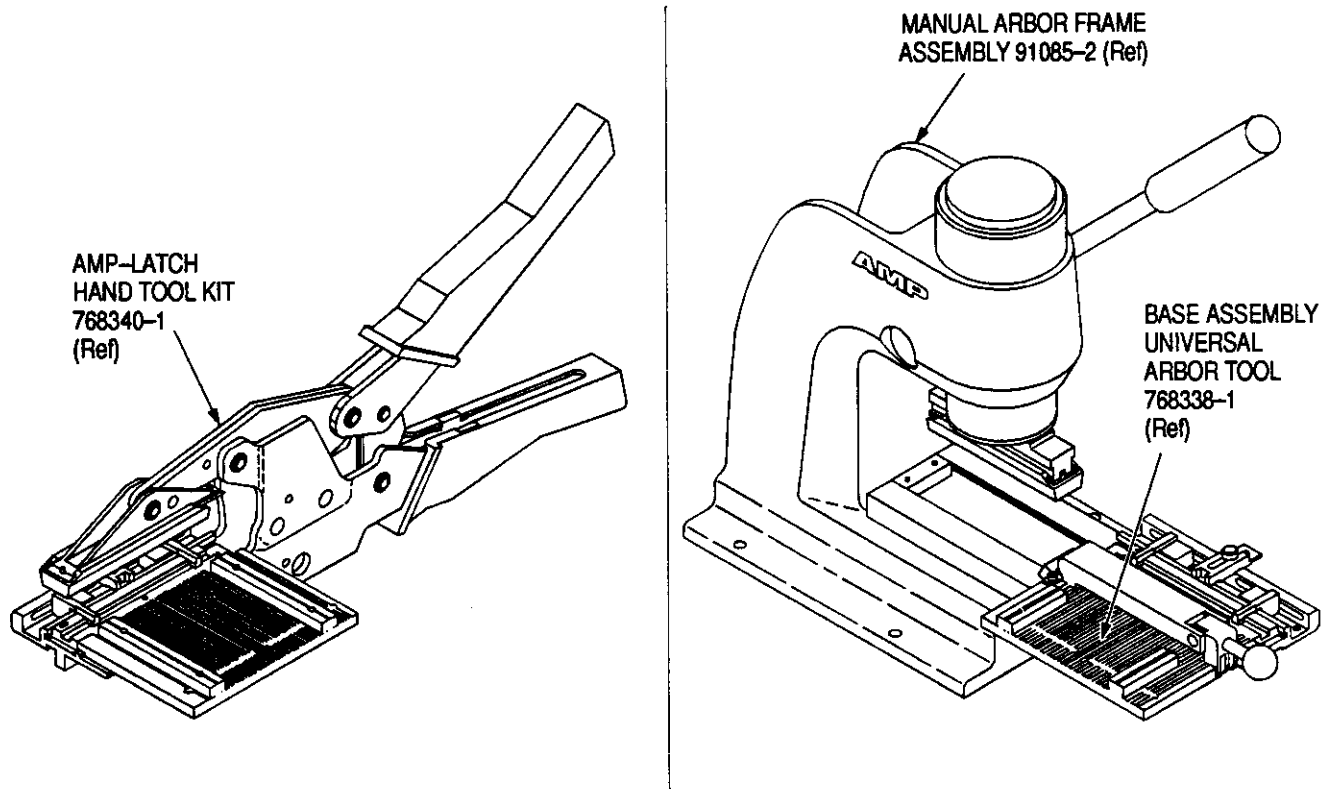

Figure 1

cad

1. INTRODUCTION

This instruction sheet covers the description, cable requirements, and installation procedures for AMP Connector-Specific Kit 768341-1, which is used with AMP-LATCH Hand Tool Kit 768340-1 (see instruction

sheet 408-9828) and Base Assembly Universal Arbor Tool 768338-1 (see 408-9827). The connector-specific kit will terminate AMP-LATCH Standard and Novo Receptacle Connectors having 1.27 mm [.050 in.] centerline spacing to ribbon cable (see Figure 2).

The Base Assembly Universal Arbor Tool is used with AMP Manual Arbor Frame Assembly 91085-2 and AMP Pneumatic Auto-Cycle Unit 91112-3. Refer to 408-7777 and 408-6732, respectively, for tooling information.

NOTE Dimensions on this sheet are in metric units [with U.S. customary equivalents in brackets].

2. DESCRIPTION (Figure 1)

The connector-specific kit features an upper tool and a lower insert. The upper tool applies an even force over the length of the connector during termination. The lower insert positions the connector on the tooling assembly. Each component is marked "AMP RCPT."

3. CABLE REQUIREMENTS

The connector-specific kit will terminate ribbon cable with 26 AWG solid or stranded conductors, 28 AWG solid or stranded conductors, or 30 AWG solid conductors to all AMP-LATCH Standard and Novo Receptacle Connectors. Refer to Figure 2 for the recommended cable dimensions.

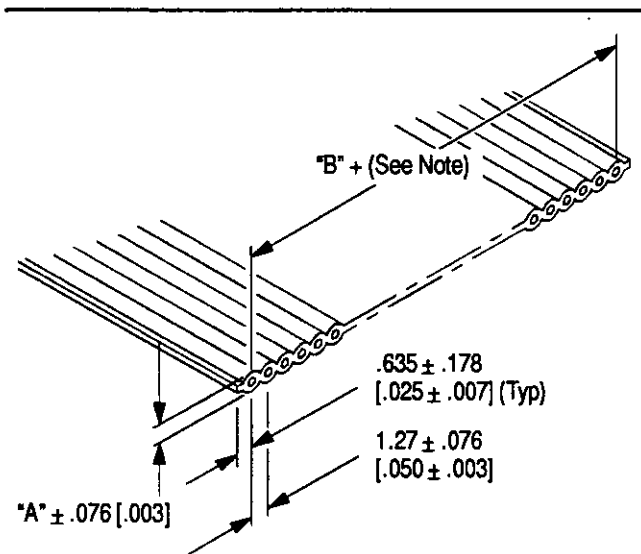

NOTE
ACCUMULATIVE TOLERANCE FOR CABLE CONDUCTORS 1 THROUGH 34 IS + .254 [0.010] AND THROUGH 60 IS + .38 [0.015].

CONDUCTOR		DIMENSION	
SIZE (AWG)	TYPE	"A"	"B"
26	Stranded or Solid	0.889 mm [.035 IN.]	1.27 mm [.050 IN.] X (Total No. of Conductors Minus One)
28	Stranded or Solid		
30	Solid		

Figure 2

cad 9831

CAUTION The cable must be cut 90° to the edge of the cable; otherwise an improper termination will result. We suggest you use a guillotine-type cable cutter, such as the Carpenter Model 95 which can be purchased from:

Carpenter Manufacturing Co., Inc.
Fairgrounds Drive
Manlius, N.Y. 13207

AMP-LATCH HAND TOOL KIT 768340-1 (Ref)
(Includes AMP-LATCH Hand Tool Subassembly 768942-1 and Base Assembly Universal Hand Tool 768339-1. Refer to 408-9846 and 408-9826)

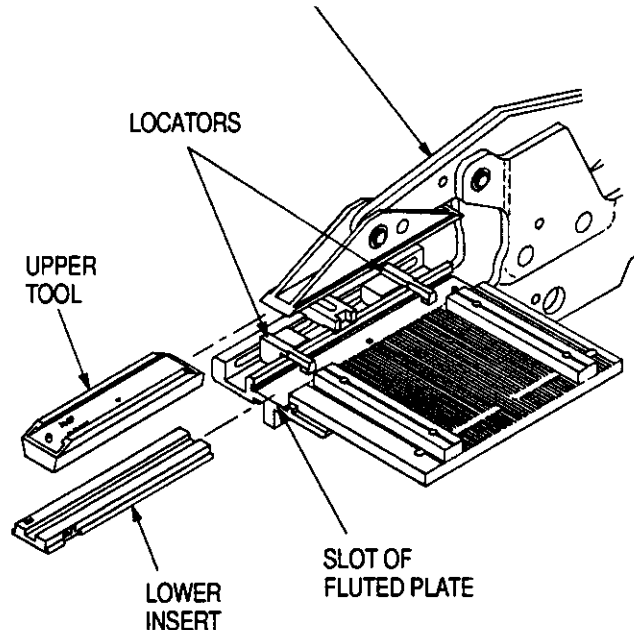

Figure 3

cad

4. CONNECTOR-SPECIFIC KIT INSTALLATION (Figures 3 and 4)

NOTE For hand tool applications, mount the hand tool onto a suitable work surface, whenever possible, before terminating the connectors. Refer to the bench-clamping instructions in 408-9828, packaged with the AMP-LATCH Hand Tool Kit.

1. Slide the upper tool onto the upper tool mount.
2. Slide the lower insert into the slot of the fluted plate.

This completes the installation procedure.

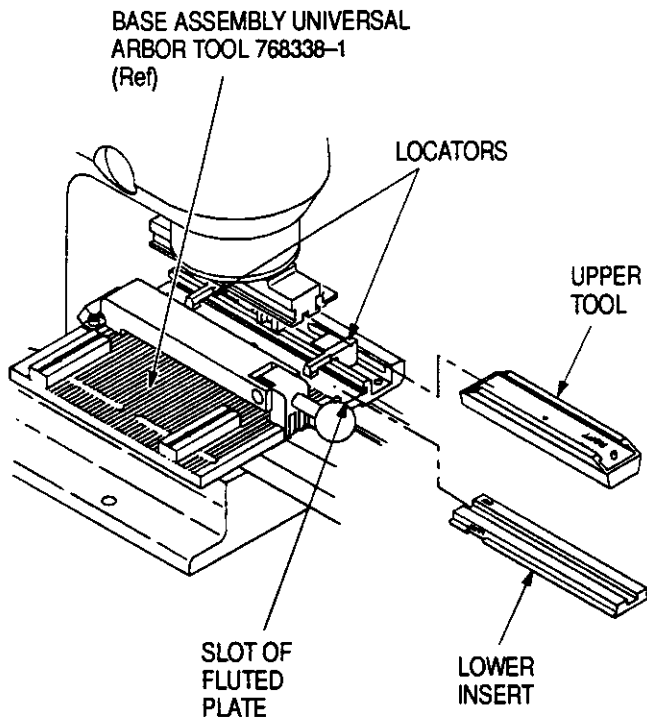

Figure 4

cad

NOTE

For information concerning termination procedures, refer to 408-9828 packaged with the AMP-LATCH Hand Tool Kit, and 408-9827 packaged with the Base Assembly Universal Arbor Tool.

5. CONNECTOR-SPECIFIC KIT INSPECTION

Connector-Specific Kit 768341-1 has been inspected and should be verified with the information provided in Figure 5. It is recommended that the connector-specific kit be inspected immediately upon its arrival at your facility (and at regularly scheduled intervals) to ensure that the kit components have not been damaged during handling.

For additional information concerning connector-specific kits, or to purchase additional kits, contact your local AMP representative or:

CUSTOMER SERVICE (38-35)
AMP INCORPORATED
P.O. BOX 3608
HARRISBURG, PA 17105-3608

CONNECTOR-SPECIFIC KIT 768341-1

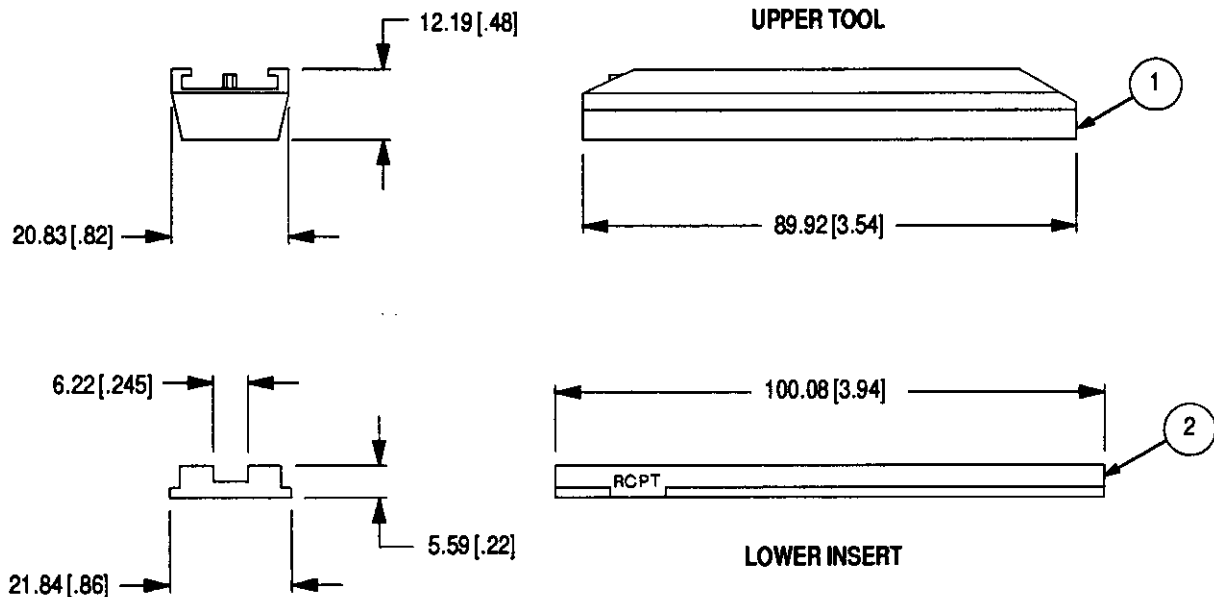

COMPONENT LIST

ITEM NO.	PART NUMBER	DESCRIPTION	QTY
1	543274-1	Upper Tool	1
2	543275-1	Lower Insert	1

Figure 5

cad