



Chipsmall Limited consists of a professional team with an average of over 10 year of expertise in the distribution of electronic components. Based in Hongkong, we have already established firm and mutual-benefit business relationships with customers from,Europe,America and south Asia,supplying obsolete and hard-to-find components to meet their specific needs.

With the principle of “Quality Parts,Customers Priority,Honest Operation,and Considerate Service”,our business mainly focus on the distribution of electronic components. Line cards we deal with include Microchip,ALPS,ROHM,Xilinx,Pulse,ON,Everlight and Freescale. Main products comprise IC,Modules,Potentiometer,IC Socket,Relay,Connector.Our parts cover such applications as commercial,industrial, and automotives areas.

We are looking forward to setting up business relationship with you and hope to provide you with the best service and solution. Let us make a better world for our industry!



Contact us

Tel: +86-755-8981 8866 Fax: +86-755-8427 6832

Email & Skype: info@chipsmall.com Web: www.chipsmall.com

Address: A1208, Overseas Decoration Building, #122 Zhenhua RD., Futian, Shenzhen, China



SPECIFICATION CONTROL DRAWING

7724S1664

CHEMINAX

77 OHM, AWG 24, 19 STRANDS OF AWG 36, OPTIMIZED SHIELD,
DATA BUS CABLE, MIL-STD-1553, OUTER SPACE USE

Date: 8-15-14
Revision: F

THIS SPECIFICATION SHEET FORMS A PART OF THE LATEST ISSUE OF RAYCHEM SPECIFICATION 1200.

CONSTRUCTION DETAILS

ELECTRICAL CHARACTERISTICS

DIMENSIONS ARE NOMINAL VALUES IN INCHES, UNLESS OTHERWISE DESIGNATED.

CHARACTERISTIC IMPEDANCE 77 ± 5 ohms, Method C at 1 MHz
MUTUAL CAPACITANCE 30.0 pF/ft. (maximum)
ATTENUATION 1.4 dB/100 ft. (maximum) at 1 MHz
SURFACE TRANSFER IMPEDANCE 100 milliohms/meter (maximum) at 30 MHz (Per SAE AS85485)

ADDITIONAL REQUIREMENTS

COMPONENT WIRE PRIOR TO CABLING
(Test procedures per SAE AS22759)

CONDUCTOR RESISTANCE 26.5 ohms/1000 ft. (nominal)
CROSSLINKING PROOF TEST 300 ± 3°C for 1 hour, .625 inch mandrel, .375 lb, 2.5 kV dielectric test
INSULATION (DIELECTRIC)
ELONGATION 50% (minimum)
TENSILE STRENGTH 5000 lbf/in² (minimum)
INSULATION FLAWS
SPARK TEST 3.0 kV (rms)
IMPULSE TEST 8.0 kV (peak)
INSULATION RESISTANCE 5000 megohms for 1000 ft. (minimum)
LOW TEMPERATURE-COLD BEND -65 ± 3°C for 4 hours, .750 inch mandrel, 1.00 lb, 2.5 kV dielectric test
SHRINKAGE 200 ± 3°C for 1 hour, .125 inch (maximum) in 12 inches

FINISHED CABLE

(Test procedures per NEMA WC 27500, unless otherwise specified)

BLOCKING 200°C for 6 hours
CABLE LAY LENGTH .75 inch (minimum), 1.25 inches (maximum)
CROSSLINKED VERIFICATION 300 ± 5°C for 6 hours, 6.00 inch mandrel
FLAMMABILITY 3 seconds (maximum); 3 inches (maximum); no flaming of facial tissue (Method B of Spec 1200)
JACKET
ELONGATION 50% (minimum)
TENSILE STRENGTH 5000 lbf/in² (minimum)
JACKET FLAWS
SPARK TEST 1.0 kV (rms)
IMPULSE TEST 6.0 kV (peak)
JACKET THICKNESS .008 inch (nominal)
LOW TEMPERATURE-COLD BEND -55 ± 5°C for 4 hours, 6.00 inch mandrel
VOLTAGE WITHSTAND 1500 volts (rms) (DIELECTRIC)

WEIGHT 14.5 lbs/1000 ft. (nominal)

OUTER SPACE REQUIREMENTS

RADIATION RESISTANCE 500 megarads, 3.75 inch mandrel, 1.0 kV dielectric test
VACUUM STABILITY
TOTAL MASS LOSS (TML) 1.00% (maximum)
VOLATILE CONDENSABLE MATERIAL (VCM) 0.10% (maximum)
WEIGHT LOSS 0.45% (maximum)

ENGINEERING REFERENCE

TEMPERATURE RATING 200°C (maximum)

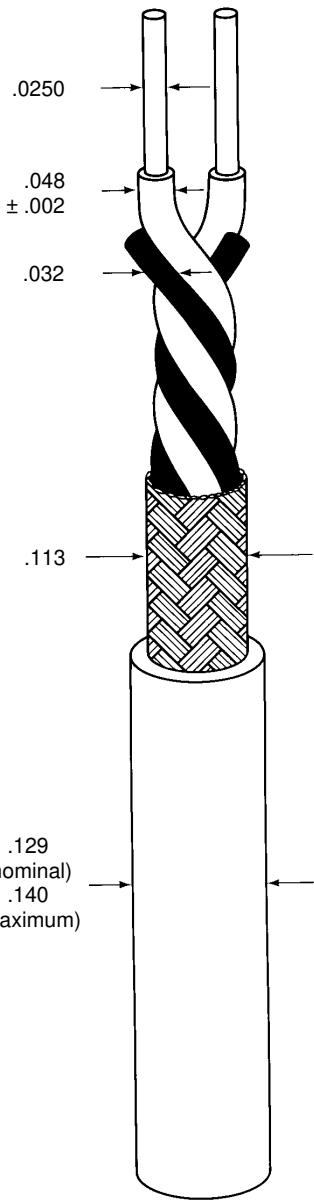

CONDUCTORS
AWG 24,
19 Strands of AWG 36,
Silver-Coated High-Strength Copper Alloy

DIELECTRICS
Low Outgassing,
Radiation-Crosslinked,
Modified ETFE
Colors - Light Blue/White

FILLERS
Low Outgassing,
Radiation-Crosslinked,
Modified ETFE

SHIELD
AWG 38,
Silver-Coated Copper,
Optimized

JACKET
Low Outgassing,
Radiation-Crosslinked,
Modified ETFE

Designate outer jacket color with a dash number in accordance with MIL-STD-681. Unless otherwise specified, outer jacket color will be white (designated by a "-9" appended to the part number, e.g. 7724S1664-9). Other codes and suffixes may be added to the part number, as necessary, to capture any additional requirements imposed by the purchase order.

Users should evaluate the suitability of this product for their application. Specifications are subject to change without notice. Tyco Electronics Corporation also reserves the right to make changes in materials or processing, which do not affect compliance with any specification, without notification to Buyer.

