



Chipsmall Limited consists of a professional team with an average of over 10 year of expertise in the distribution of electronic components. Based in Hongkong, we have already established firm and mutual-benefit business relationships with customers from,Europe,America and south Asia,supplying obsolete and hard-to-find components to meet their specific needs.

With the principle of “Quality Parts,Customers Priority,Honest Operation,and Considerate Service”,our business mainly focus on the distribution of electronic components. Line cards we deal with include Microchip,ALPS,ROHM,Xilinx,Pulse,ON,Everlight and Freescale. Main products comprise IC,Modules,Potentiometer,IC Socket,Relay,Connector.Our parts cover such applications as commercial,industrial, and automotives areas.

We are looking forward to setting up business relationship with you and hope to provide you with the best service and solution. Let us make a better world for our industry!



Contact us

Tel: +86-755-8981 8866 Fax: +86-755-8427 6832

Email & Skype: info@chipsmall.com Web: www.chipsmall.com

Address: A1208, Overseas Decoration Building, #122 Zhenhua RD., Futian, Shenzhen, China



PRODUCT NUMBER

77319-YXX-XXLF

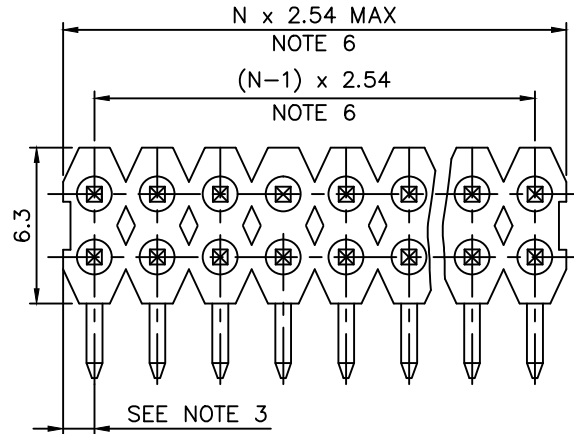
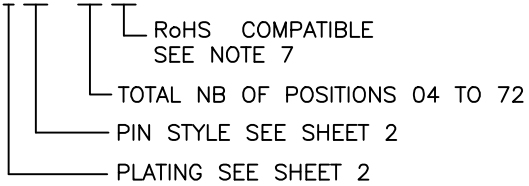

NOTES:

- HOUSING MAT'L : HIGH TEMPERATURE THERMOPLASTIC. UL94V-0 COLOR: BLACK
- PIN MATERIAL : PHOSPHOR BRONZE
- DIM 1.27^{+0.03}/_{-0.13} FOR MOULDED SIDE(S) ONLY. IF SIDE(S) ARE BROKEN, DIM 1.02 TO 1.7 MAX APPLIES.
- PRODUCT PACKAGED IN POLY BAGS.
- 9N MIN RETENTION IN EITHER DIRECTION
- TO DETERMINE DIMENSIONS :
N = NUMBER OF POSITIONS PER ROW
EXAMPLE : 8 POS $N \times 2.54 = 20.32\text{mm}$
- RoHS COMPATIBLE PRODUCT SPECIFICATIONS
 - PLATING:
- "LF" MEANS THE PRODUCT IS LEAD-FREE, 2µm MINIMUM MATTE TIN OVER 1.27µm MINIMUM NICKEL UNDERPLATE.
 - MANUFACTURING PROCESS COMPATIBILITY
- THE HOUSING WILL WITHSTAND EXPOSURE TO 260°C ±5°C SOLDER BATH TEMPERATURE FOR 5 SECONDS IN A WAVE SOLDER APPLICATION WITH A 1.6mm MIN THICK CIRCUIT BOARD.
 - LABELLING:
- MEETS PACKAGING SPECS AS PER GS-14-920
 - LEGAL STATEMENT : SEE GS-47-0004

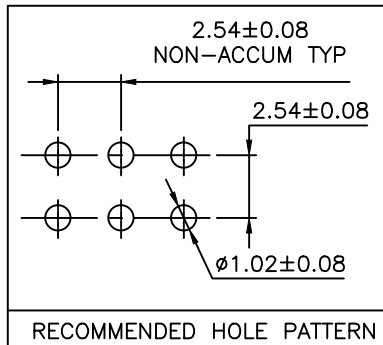
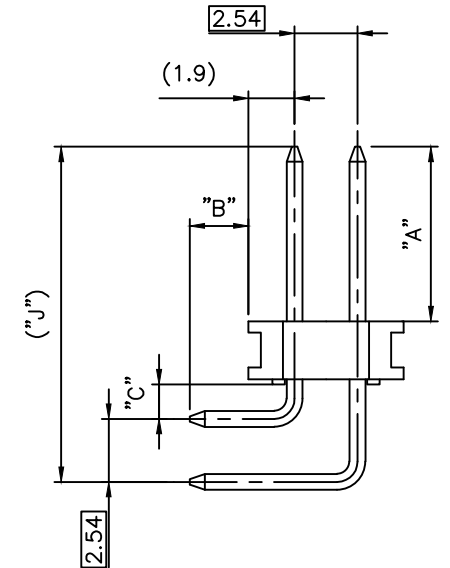
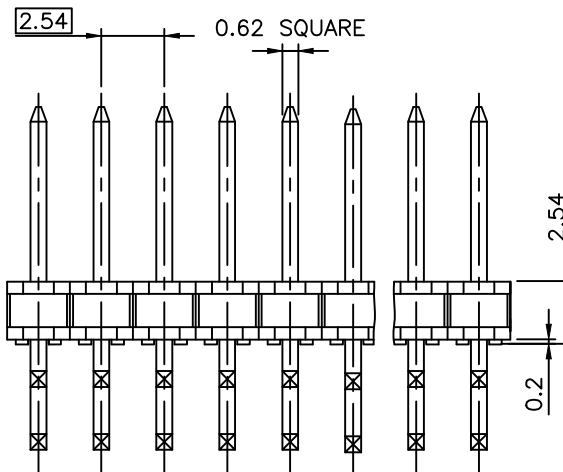

mat'l. code		surface	tolerance	projection	product family
		ISO 1302	ISO 406 ISO 1101		BSTIK
ltr ecn no dr date		tolerances unless otherwise specified			title
R	F08-0148	RTR	08.03.31	mm	HEADER RA,DR, WIDE BODY 2.54mm
S	F11-0036	JCO	10.03.14	angles	linear
T	F11-0320	LMU	12.01.25	scale 5:1	
U	B-18916	LMU	14.09.29	dr	COMPAGNON J 95.11.15
				enrg	JMC 95.11.15
N	F05-0186	LMU	05.06.09	chr	JMC 95.11.15
P	F06-0207	LMU	06.07.27	appd	JMC 95.11.15
sheet index	revision sheet	U	S		
		1	2		
dwg no		sheet 1 of 2		size	
77319				A3	
type		CUSTOMER Drawing			

PIN STYLE	PRODUCT DIMENSIONS			
	"A" ±0.15	"B" ±0.35	("C") REF	("J") REF
01	5.72	3.05	1.52	12.19
02	5.72	3.70	1.52	12.19
03	8.08	2.93	1.52	14.68
04	5.84	2.83	1.52	12.44
05	7.15	3.05	1.52	13.75
06	6.10	3.10	1.52	12.70
07	10.89	3.05	1.52	17.49

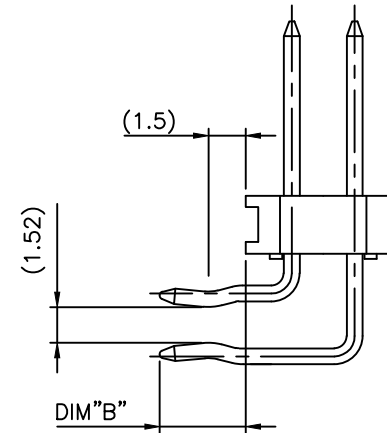
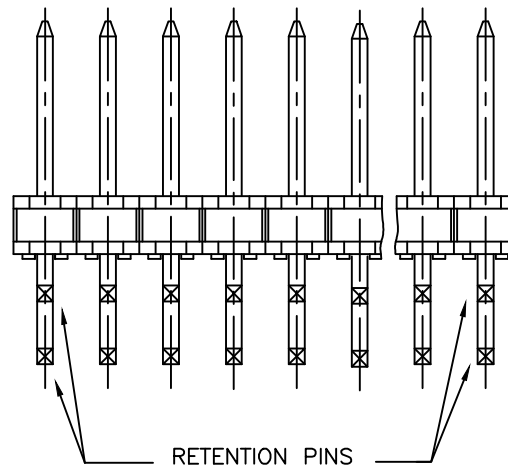

OPTION LETTER "R"
FOR RETENTION
77319-YXXRXXLF

NOTES:

- 4 PINS USED FOR RETENTION FEATURE ,2 AT EACH END
- RETENTION FEATURE ONLY AVAILABLE WHEN DIM "B" IS BETWEEN 2.9 AND 3.5mm.

77319-SXX-XXLF	0.38µm GXT FULL PLATED	
77319-GXX-XXLF	0.76µm GXT FULL PLATED	
77319-9XX-XXLF	0.2µm Au	2.0-7.5 Sn MATTE
77319-8XX-XXLF	0.38µm Au/GXT	2.0-7.5 Sn MATTE
77319-5XX-XXLF	0.25µm Au/GXT	2.0-7.5 Sn MATTE
77319-4XX-XXLF	3.81µm Sn FULL PLATED	
77319-2XX-XXLF	1.27µm Au	2.0-7.5 Sn MATTE
77319-1XX-XXLF	0.76µm Au/GXT	2.0-7.5 Sn MATTE
77319-1XXSXXLF	0.76µm Au/GXT	GOLD FLASH
PLATING CODE	CONTACT AREA	REMAINDER
	PLATING THICKNESS OVER 1.27µm Ni	

mat'l. code		surface		tolerance		projection	product family	
		ISO 1302	ISO 406	ISO 1101	ISO 1101	mm	BSTIK	
ltr	ecn no	dr	date	tolerances unless otherwise specified		title		
R	F11-0320	LMU	12.01.25	angles	linear	HEADER RA,DR, WIDE BODY 2.54mm		
S	B-18916	LMU	14.09.29			scale 5:1	sheet 2 of - size	
L	F00837	LMU	00.11.10	dr	COMPAGNON J	95.11.15	A3	
M	F05-0186	LMU	05.06.09	enr	JMC	95.11.15	77319	
N	F06-0207	LMU	06.07.27	chr	JMC	95.11.15	type CUSTOMER Drawing	
P	F08-0148	RTR	08.03.31	appd	JMC	95.11.15		
sheet index	revision sheet							