



Chipsmall Limited consists of a professional team with an average of over 10 year of expertise in the distribution of electronic components. Based in Hongkong, we have already established firm and mutual-benefit business relationships with customers from,Europe,America and south Asia,supplying obsolete and hard-to-find components to meet their specific needs.

With the principle of “Quality Parts,Customers Priority,Honest Operation,and Considerate Service”,our business mainly focus on the distribution of electronic components. Line cards we deal with include Microchip,ALPS,ROHM,Xilinx,Pulse,ON,Everlight and Freescale. Main products comprise IC,Modules,Potentiometer,IC Socket,Relay,Connector.Our parts cover such applications as commercial,industrial, and automotives areas.

We are looking forward to setting up business relationship with you and hope to provide you with the best service and solution. Let us make a better world for our industry!



Contact us

Tel: +86-755-8981 8866 Fax: +86-755-8427 6832

Email & Skype: info@chipsmall.com Web: www.chipsmall.com

Address: A1208, Overseas Decoration Building, #122 Zhenhua RD., Futian, Shenzhen, China





FEATURES

- RoHS compliant
- Analog Devices ADM2485 compatible
- 2.5kVrms isolation
- Industry-standard pinout
- UL 94 V-0 package materials
- Low profile
- Toroidal construction
- Fully encapsulated
- Industrial temperature range
- Surface mount versions available soon
- Recommended by Analog Devices, Inc.
- Backward compatible with Sn/Pb soldering systems

DESCRIPTION

The 782485 series of converter transformers are specifically designed for use with Analog Devices chipsets to provide isolated RS-485 and RS-422 interfaces. Carefully controlled turns ratios ensure consistent performance whilst a toroidal construction minimises EMI.

SELECTION GUIDE

Order Code	Nominal Input Voltage	Nominal Output Voltage	Max. Output Current	Isolation Voltage	Turns Ratio	Package Style
	V	V	mA	V _{RMS}		
782485/35C	3.3	6.0	200	2500	1CT:2.2CT	DIL
782485/55C	5.0	6.0	200	2500	1CT:1.5CT	DIL

CHARACTERISTICS 782485/35C

Parameter	Conditions	782485/35C		782485/55C		Units
		Typ.	Max.	Typ.	Max.	
Primary Inductance, L _p	100kHz, 10mV	234		513		µH
Leakage Inductance, L _l	100kHz, 10mV	168		192		nH
Interwinding Capacitance, C _{ww}	100kHz, 10mV	24	50	37	50	pF
Primary DC Resistance, R _{dc}	<0.1VDC	273	500	383	600	mΩ
Volt-time Product, Et ¹	5kHz, 5V	12		19		Vµs

ABSOLUTE MAXIMUM RATINGS

Operating free air temperature range	-40°C to 85°C
Storage temperature range	-50°C to 125°C
Isolation voltage (flash tested for 1 second)	2.5kVrms

SOLDERING INFORMATION²

Peak wave solder temperature	300°C for 10 seconds
Pin finish	Matte tin

Specifications typical at T_a = 25°C

¹ Where pulse applied across pins 1 and 2.

² For further information, please visit www.murata-ps.com/rohs

TECHNICAL NOTES

ISOLATION VOLTAGE

'Hi Pot Test', 'Flash Tested', 'Withstand Voltage', 'Proof Voltage', 'Dielectric Withstand Voltage' & 'Isolation Test Voltage' are all terms that relate to the same thing, a test voltage, applied for a specified time, across a component designed to provide electrical isolation, to verify the integrity of that isolation.

All products in this series are 100% production tested at their stated isolation voltage.

A question commonly asked is, "What is the continuous voltage that can be applied across the part in normal operation?"

For a part holding no specific agency approvals both input and output should normally be maintained within SELV limits i.e. less than 42.4V peak, or 60VDC. The isolation test voltage represents a measure of immunity to transient voltages and the part should never be used as an element of a safety isolation system. The part could be expected to function correctly with several hundred volts offset applied continuously across the isolation barrier; but then the circuitry on both sides of the barrier must be regarded as operating at an unsafe voltage and further isolation/insulation systems must form a barrier between these circuits and any user-accessible circuitry according to safety standard requirements.

REPEATED HIGH-VOLTAGE ISOLATION TESTING

It is well known that repeated high-voltage isolation testing of a barrier component can actually degrade isolation capability, to a lesser or greater degree depending on materials, construction and environment. This series has toroidal isolation transformers, with no additional insulation between primary and secondary windings of enameled wire. While parts can be expected to withstand several times the stated test voltage, the isolation capability does depend on the wire insulation. Any material, including this enamel (typically polyurethane) is susceptible to eventual chemical degradation when subject to very high applied voltages thus implying that the number of tests should be strictly limited. We therefore strongly advise against repeated high voltage isolation testing, but if it is absolutely required, that the voltage be reduced by 20% from specified test voltage.

This consideration equally applies to agency recognized parts rated for better than functional isolation where the wire enamel insulation is always supplemented by a further insulation system of physical spacing or barriers.



PACKAGE SPECIFICATIONS

MECHANICAL DIMENSIONS

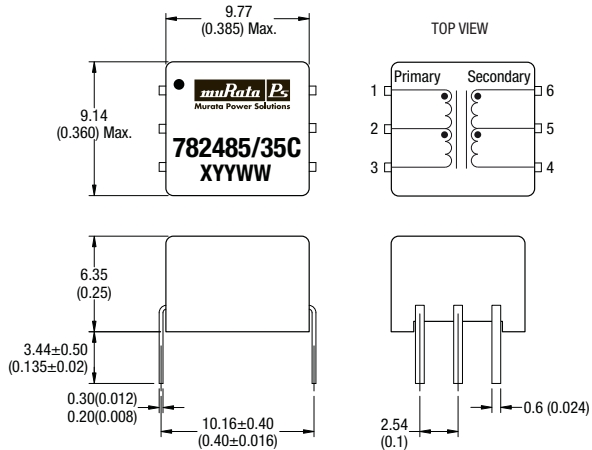

Unless otherwise stated all dimensions in mm (inches) ± 0.25 (0.01).
All pins on a 2.54 (0.1) pitch and within ± 0.25 (0.01) of true position.
Package Weight 1.0g TYP.

RECOMMENDED FOOTPRINT DETAILS

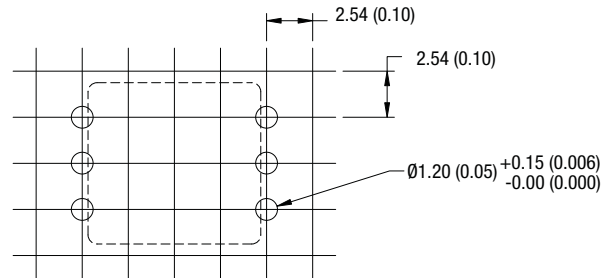

Unless otherwise stated all dimensions in mm (inches) ± 0.25 (0.01).
All pins on a 2.54(0.1) pitch and within ± 0.25 (0.01) of true position.

TUBE OUTLINE DIMENSIONS

