



Chipsmall Limited consists of a professional team with an average of over 10 year of expertise in the distribution of electronic components. Based in Hongkong, we have already established firm and mutual-benefit business relationships with customers from,Europe,America and south Asia,supplying obsolete and hard-to-find components to meet their specific needs.

With the principle of “Quality Parts,Customers Priority,Honest Operation,and Considerate Service”,our business mainly focus on the distribution of electronic components. Line cards we deal with include Microchip,ALPS,ROHM,Xilinx,Pulse,ON,Everlight and Freescale. Main products comprise IC,Modules,Potentiometer,IC Socket,Relay,Connector.Our parts cover such applications as commercial,industrial, and automotives areas.

We are looking forward to setting up business relationship with you and hope to provide you with the best service and solution. Let us make a better world for our industry!



Contact us

Tel: +86-755-8981 8866 Fax: +86-755-8427 6832

Email & Skype: info@chipsmall.com Web: www.chipsmall.com

Address: A1208, Overseas Decoration Building, #122 Zhenhua RD., Futian, Shenzhen, China



10 9 8 7 6 5 4 3 2 1

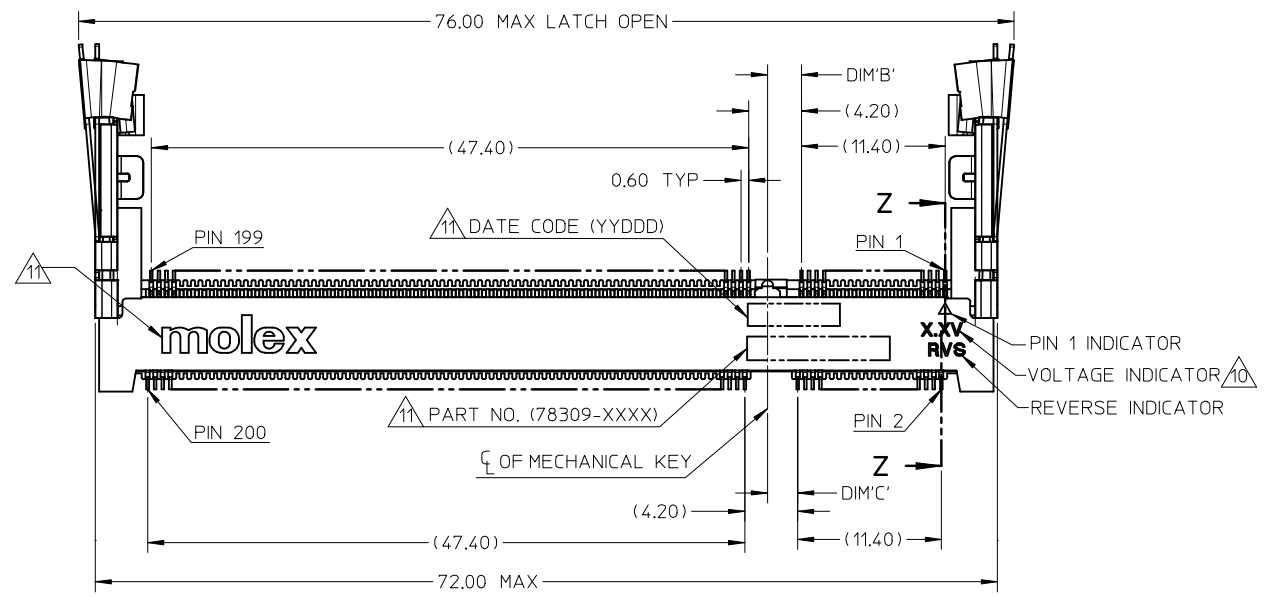
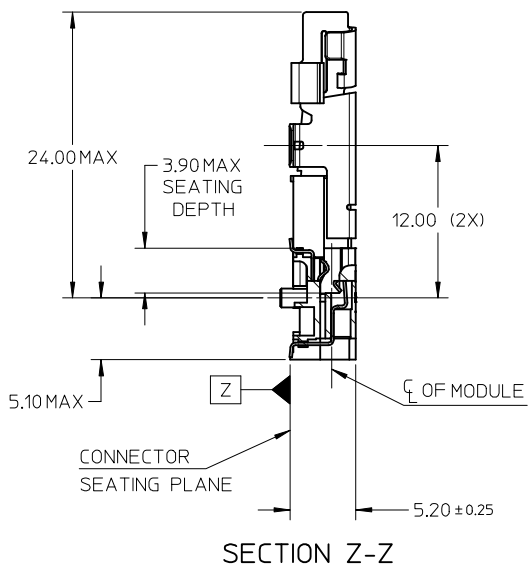

PART NO.	PACKAGING	TYPE	DIM'A'	DIM'B'	DIM'C'	VOLTAGE	CONTACT AREA FINISH
78309-1130	TRAY	DDR	18.45	1.80	1.50	2.5 V	30 MICROINCH / 0.76 MICROMETER GOLD OVER
78309-1730	TAPE & REEL						50 MICROINCH / 1.27 MICROMETER NICKEL
78309-2230	TRAY	DDR2	17.55	2.70	2.40	1.8 V	30 MICROINCH / 0.76 MICROMETER GOLD OVER
78309-2730	TAPE & REEL						50 MICROINCH / 1.27 MICROMETER NICKEL
78309-1115	TRAY	DDR	18.45	1.80	1.50	2.5 V	15 MICROINCH / 0.38 MICROMETER GOLD OVER
78309-1715	TAPE & REEL						50 MICROINCH / 1.27 MICROMETER NICKEL
78309-2215	TRAY	DDR2	17.55	2.70	2.40	1.8 V	15 MICROINCH / 0.38 MICROMETER GOLD OVER
78309-2715	TAPE & REEL						50 MICROINCH / 1.27 MICROMETER NICKEL

- NOTE :
- MATERIAL:
HOUSING: LCP - UL94V-0, COLOUR: BLACK
CONTACTS: COPPER ALLOY
LOCK LEVER: STAINLESS STEEL
 - FINISH:
CONTACT AREA: REFER TABLE IN SHEET 1.
SOLDER TAIL AREA: 100MN/2.54MM TIN OVER 50MN/1.27MM NICKEL.
LOCK LEVER SOLDER PAD: 100MN/2.54MM TIN OVER 50MN/1.27MM NICKEL.
 - PRODUCT SPEC AS PER PS-78309-001, PS-78309-002.
 - PART SHALL BE PACKED IN TRAY / TAPE & REEL.
 - RECOMMENDED MODULE LAYOUT SHALL BE AS PER JEDEC MO-224.
 - EDGE OF CONTACT PADS SHALL BE FREE OF BURRS AND EXTERNAL TIE BARS.
 - THE ADDITION OF THIS BEVEL IS A FABRICATION OPTION AND IS NOT REQUIRED. THE BEVEL AIDS THE INSERTION OF THE MODULE INTO THE CONNECTOR. THE BEVEL IS NOT TO HIT THE PLATED CONTACTS.
 - COPLANARITY INCLUDES HOLD DOWN 0.1 MAX.
 - BORDER OF COMPONENT AREA.
 - SUPPLY VOLTAGE TO BE INDICATED ON HOUSING. (SEE TABLE IN SHT 2)
 - MOLEX LOGO, DATE CODE & PART NO. TO BE INDICATED ON HOUSING.

THE DESIGN IS BASED ON DESIGN OBJECTIVES AND IS STRICTLY TENTATIVE.
IT MAY CHANGE BASED ON RESULTS OF ADDITIONAL DESIGN REVIEWS & VERIFICATION.

ADD 15AU PART No. EC NO: S2009-0212 DRWN:VMANICKAM 2008/10/10 CHKD:CCTEH 2008/10/13 APPR:SHLENI 2008/10/13	QUALITY SYMBOLS ▽=0 ◻=0	GENERAL TOLERANCES (UNLESS SPECIFIED)		DIMENSION STYLE MM ONLY		SCALE NTS	DESIGN UNITS METRIC	THIRD ANGLE PROJECTION	
		4 PLACES ± --- ± --- 3 PLACES ± --- ± --- 2 PLACES ± 0.2 ± --- 1 PLACE ± --- ± ---	mm INCH ± --- ± --- ± 0.2 ± --- ± --- ± ---	DRAWN BY DWLEE01	DATE 2007/08/31	TITLE DDR/DDR2 SO DIMM 200 CKTS, 5.2MM HEIGHT REVERSE ORIENTATION			
		ANGULAR ± 1 °		CHECKED BY VMANICKAM	DATE 2007/12/06	MOLEX INCORPORATED			
		DRAFT WHERE APPLICABLE MUST REMAIN WITHIN DIMENSIONS		APPROVED BY SHLENI	DATE 2007/12/06	MATERIAL NO. SEE TABLE E	DOCUMENT NO. SD-78309-001	SHEET NO. 1 OF 6	

9 8 7 6 5 4 3 2 1

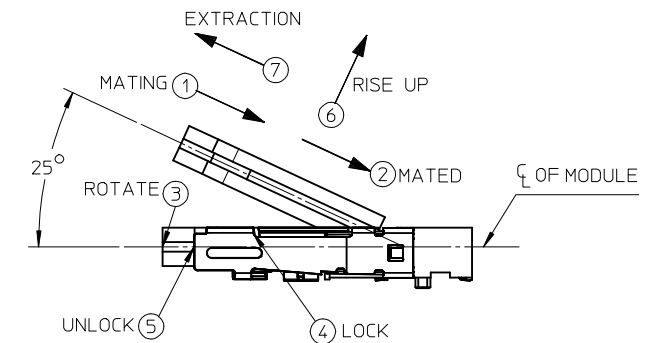
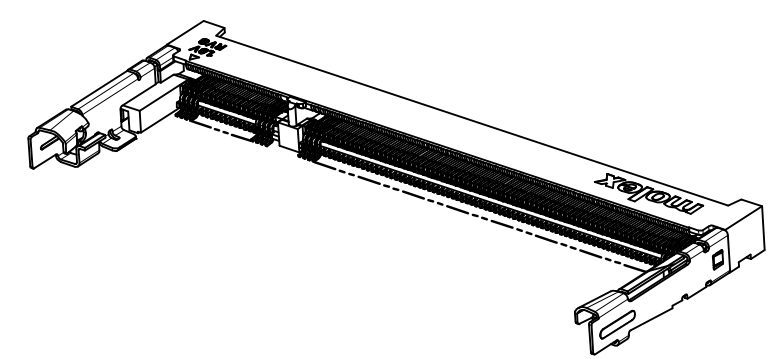
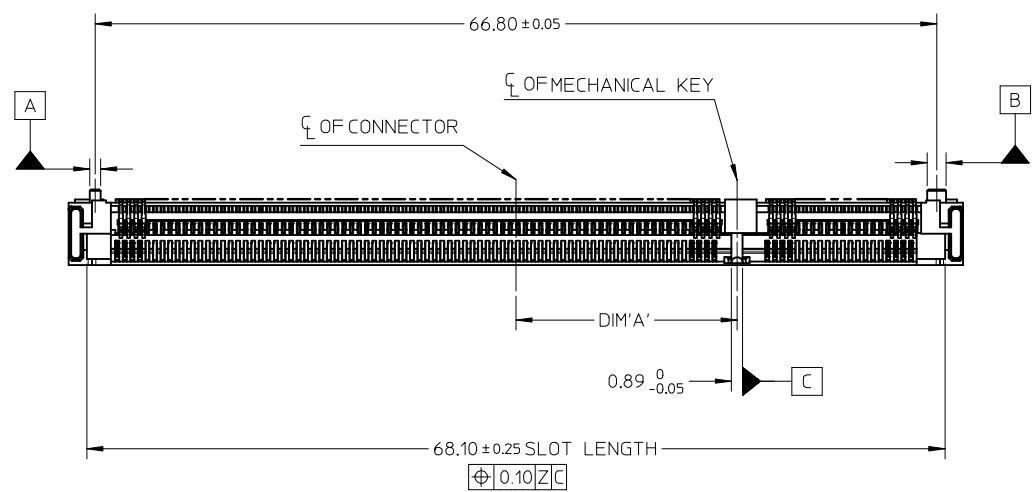

MATE AND UNMATE GUIDE	
MATE:	① → ④
UNMATE:	⑤ → ⑦

ADD 15AU PART No. EC NO: S2009-0212 DRWN: VMANICKAM 2008/10/10 CHKD: CTEH 2008/10/13 APPR: SHLENI 2008/10/13	QUALITY SYMBOLS	GENERAL TOLERANCES (UNLESS SPECIFIED)	DIMENSION STYLE	SCALE	DESIGN UNITS	THIRD ANGLE PROJECTION
	▽=0 Ⓢ=0	mm INCH 4 PLACES ± --- ± --- 3 PLACES ± --- ± --- 2 PLACES ± 0.2 ± --- 1 PLACE ± --- ± --- ANGULAR ± 1 °	MM ONLY	NTS	METRIC	
	DESCRIPTION	DRAFT WHERE APPLICABLE MUST REMAIN WITHIN DIMENSIONS	DRAWN BY: DWLEE01 DATE: 2007/08/31 CHECKED BY: VMANICKAM DATE: 2007/12/06 APPROVED BY: SHLENI DATE: 2007/12/06 MATERIAL NO.	TITLE	DDR/DDR2 SO DIMM 200 CKTS, 5.2MM HEIGHT REVERSE ORIENTATION	
	REV		SEE TABLE	MOLEX INCORPORATED DOCUMENT NO. SD-78309-001	SHEET NO. 2 OF 6	

RECOMMENDED PCB LAYOUT FOR REVERSE ORIENTATION (TOP VIEW)

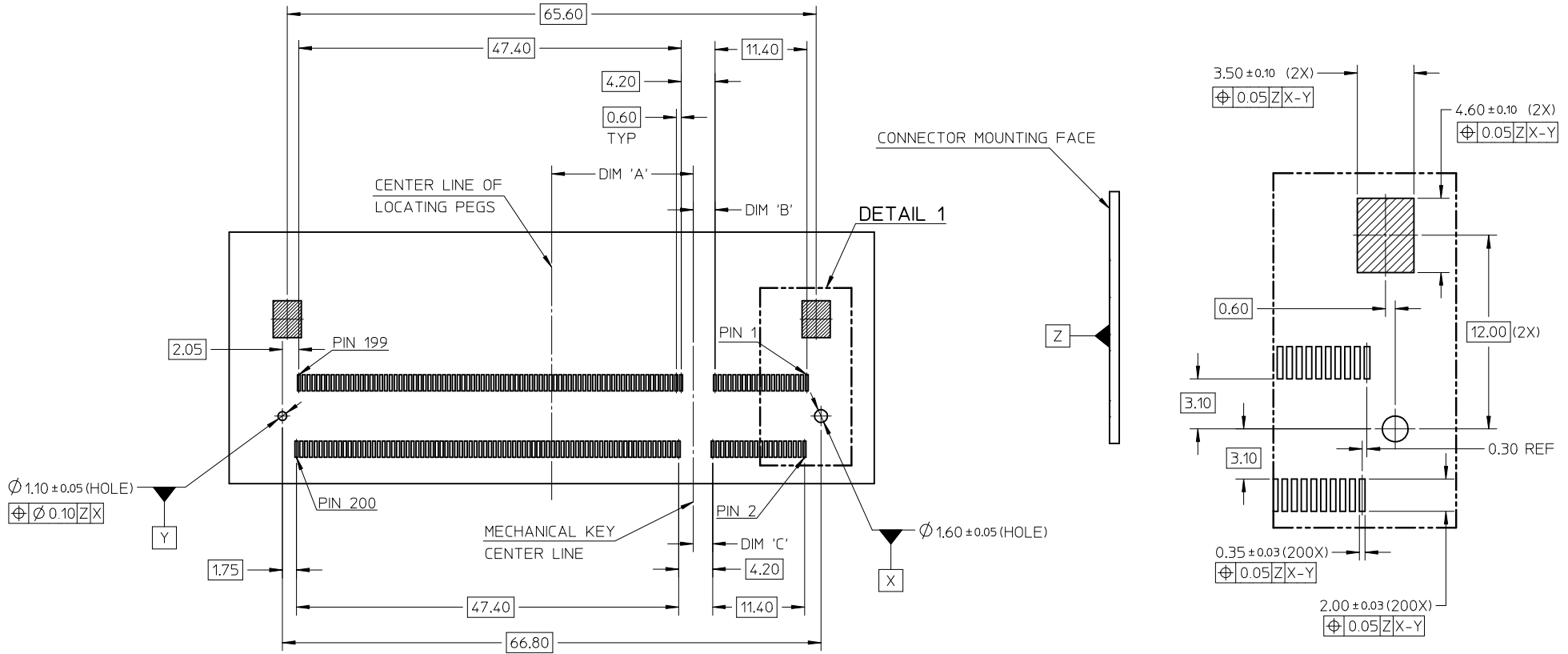

PART NO.	TYPE	DIM'A'	DIM'B'	DIM'C'	VOLTAGE
78309-1130	DDR	18.45	1.80	1.50	2.5 V
78309-1730					
78309-2230	DDR2	17.55	2.70	2.40	1.8 V
78309-2730					
78309-1115	DDR	18.45	1.80	1.50	2.5 V
78309-1715					
78309-2215	DDR2	17.55	2.70	2.40	1.8 V
78309-2715					

ADD 15AU PART No. EC NO: S2009-0212 DRWN:VMANICKAM 2008/10/10 CHKD:CCTEH 2008/10/13 APPR:SHLENI 2008/10/13	QUALITY SYMBOLS ▽=0 ◻=0	GENERAL TOLERANCES (UNLESS SPECIFIED)		DIMENSION STYLE MM ONLY		SCALE NTS	DESIGN UNITS METRIC	THIRD ANGLE PROJECTION	
			mm	INCH	DRAWN BY DWLEE01	DATE 2007/08/31	TITLE DDR/DDR2 SO DIMM 200 CKTS, 5.2MM HEIGHT REVERSE ORIENTATION		
			4 PLACES ± --- ± ---	3 PLACES ± --- ± ---	CHECKED BY VMANICKAM	DATE 2007/12/06	MOLEX INCORPORATED		
			2 PLACES ± 0.2 ± ---	1 PLACE ± --- ± ---	APPROVED BY SHLENI	DATE 2007/12/06	DOCUMENT NO. SD-78309-001		
		ANGULAR ± 1 °		MATERIAL NO. SEE TABLE		SHEET NO. 3 OF 6			
DRAFT WHERE APPLICABLE MUST REMAIN WITHIN DIMENSIONS				THIS DRAWING CONTAINS INFORMATION THAT IS PROPRIETARY TO MOLEX INCORPORATED AND SHOULD NOT BE USED WITHOUT WRITTEN PERMISSION					

RECOMMENDED MATING PCB CONFIGURATION

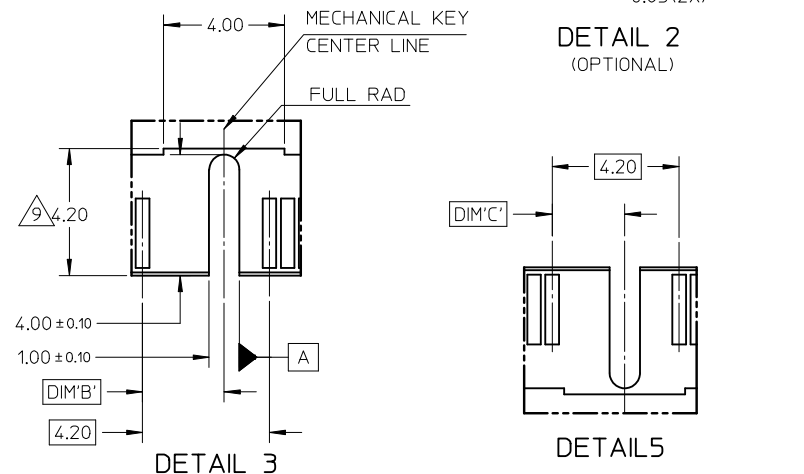
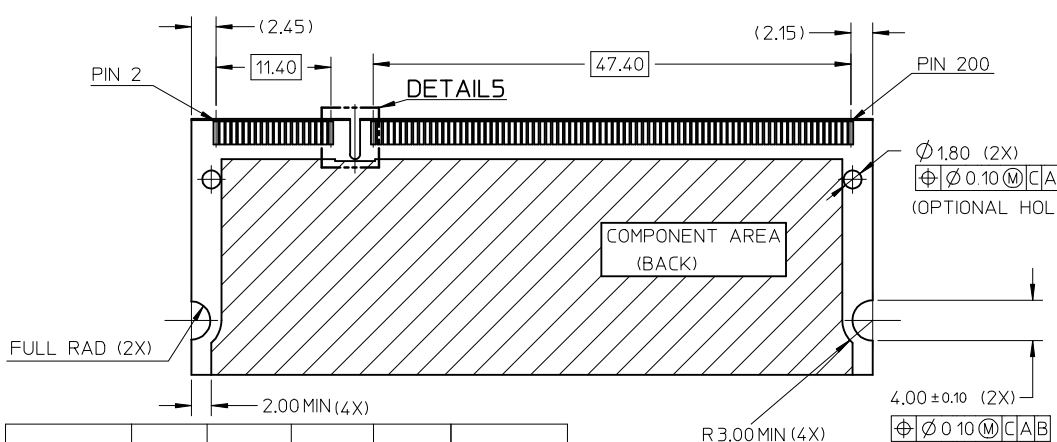
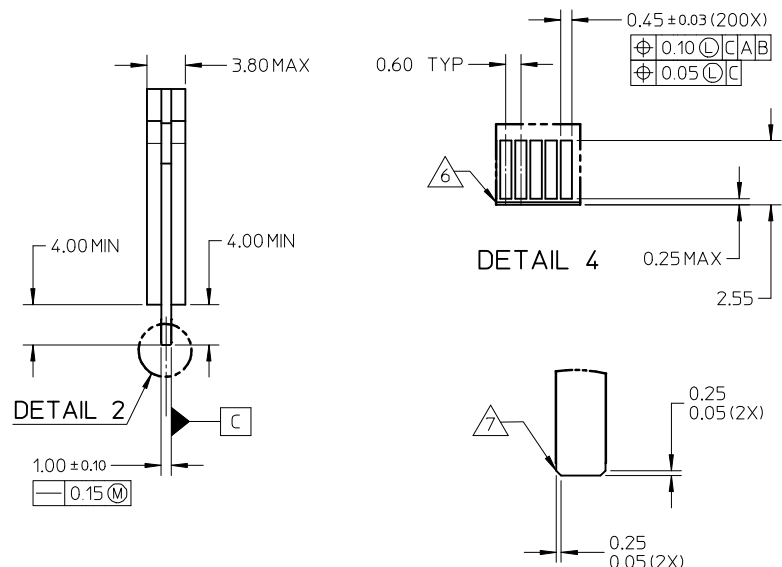
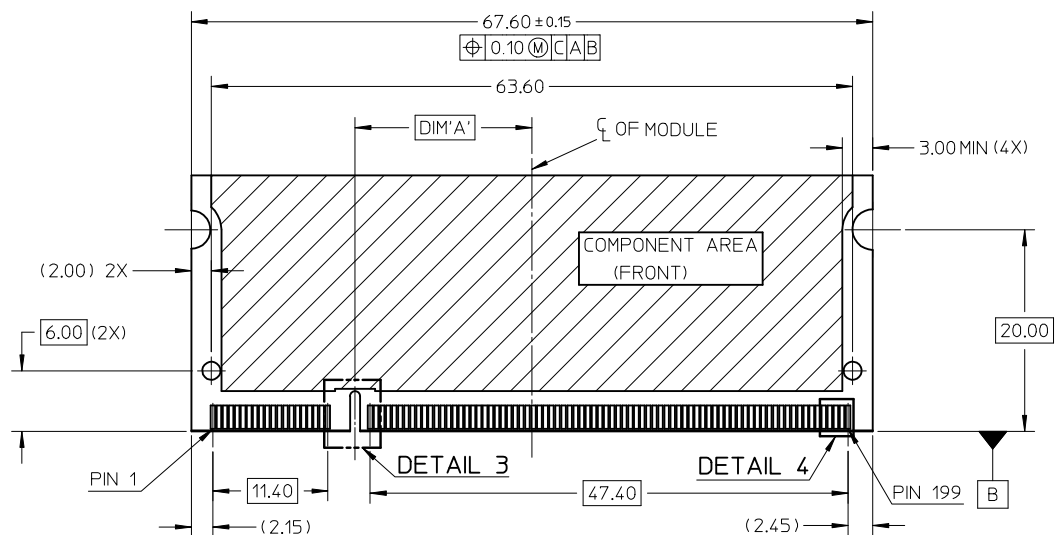

PART NO.	TYPE	DIM'A'	DIM'B'	DIM'C'	VOLTAGE
78309-1130	DDR	18.45	1.80	1.50	2.5 V
78309-1730					
78309-2230	DDR2	17.55	2.70	2.40	1.8 V
78309-2730					
78309-1115	DDR	18.45	1.80	1.50	2.5 V
78309-1715					
78309-2215	DDR2	17.55	2.70	2.40	1.8 V
78309-2715					

ADD 15AU PART No. EC NO: S2009-0212 DRWN:VMANICKAM 2008/10/10 CHKD:CCTEH 2008/10/13 APPR:SHLENI 2008/10/13	QUALITY SYMBOLS	GENERAL TOLERANCES (UNLESS SPECIFIED)	DIMENSION STYLE	SCALE	DESIGN UNITS	THIRD ANGLE PROJECTION
	▽=0 ◻=0	mm INCH 4 PLACES ± --- ± --- 3 PLACES ± --- ± --- 2 PLACES ± 0.2 ± --- 1 PLACE ± --- ± --- ANGULAR ± 1°	MM ONLY	NTS	METRIC	
			DRAWN BY DATE	TITLE	DDR/DDR2 SO DIMM	
			CHECKED BY DATE		200 CKTS, 5.2MM HEIGHT	
			APPROVED BY DATE		REVERSE ORIENTATION	
			MATERIAL NO.		MOLEX INCORPORATED	
					DOCUMENT NO.	SHEET NO.
		DRAFT WHERE APPLICABLE MUST REMAIN WITHIN DIMENSIONS	SEE TABLE		SD-78309-001	4 OF 6
			SIZE A3	THIS DRAWING CONTAINS INFORMATION THAT IS PROPRIETARY TO MOLEX INCORPORATED AND SHOULD NOT BE USED WITHOUT WRITTEN PERMISSION		

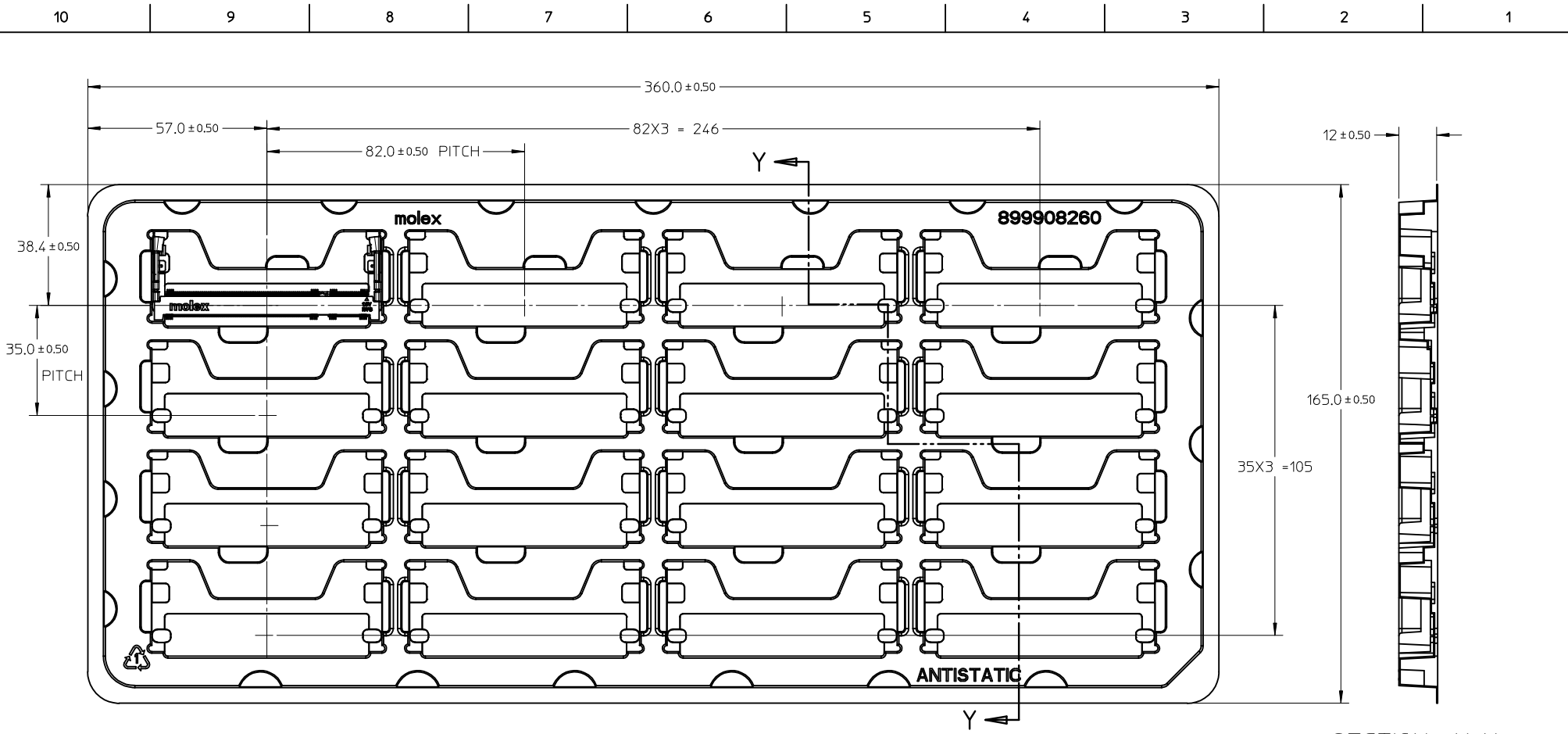

SECTION Y-Y

NOTE:

1. NO. OF CAVITY: 4 X 4 = 16

ADD 15AU PART No. EC NO: S2009-0212 DRWN:VMANICKAM 2008/10/10 CHKD:CCTEH 2008/10/13 APPR:SHLENI 2008/10/13	DESCRIPTION REV	QUALITY SYMBOLS	GENERAL TOLERANCES (UNLESS SPECIFIED)		DIMENSION STYLE MM ONLY		SCALE NTS	DESIGN UNITS METRIC	THIRD ANGLE PROJECTION	
		$\nabla = 0$ $\square = 0$	mm	INCH	DRAWN BY DWLEE01	DATE 2007/08/31	TITLE DDR/DDR2 SO DIMM 200 CKTS, 5.2MM HEIGHT REVERSE ORIENTATION			
		4 PLACES	± ---	± ---	CHECKED BY VMANICKAM	DATE 2007/12/06	MOLEX INCORPORATED			
		3 PLACES	± ---	± ---	APPROVED BY SHLENI	DATE 2007/12/06	MATERIAL NO.	DOCUMENT NO.	SHEET NO.	
DRAFT WHERE APPLICABLE MUST REMAIN WITHIN DIMENSIONS		ANGULAR ± 1 °		SEE TABLE		SD-78309-001		5 OF 6		
THIS DRAWING CONTAINS INFORMATION THAT IS PROPRIETARY TO MOLEX INCORPORATED AND SHOULD NOT BE USED WITHOUT WRITTEN PERMISSION										

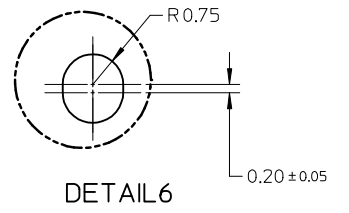
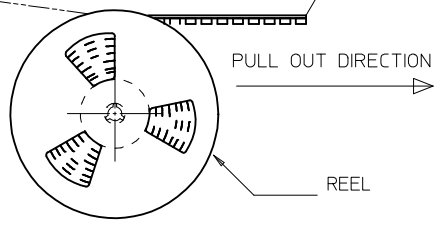
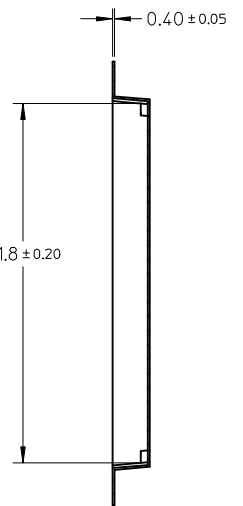
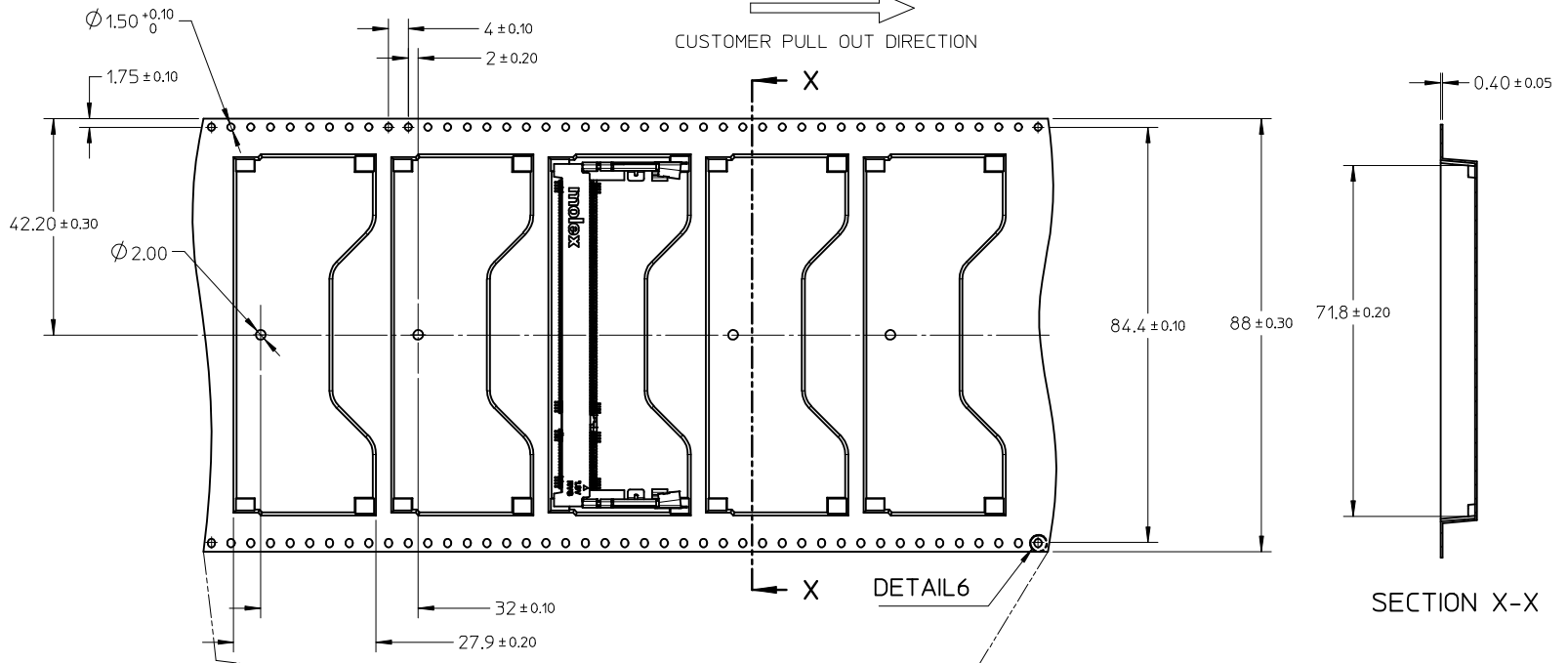

NOTES:

1. LEADER AND TRAILER TAPE

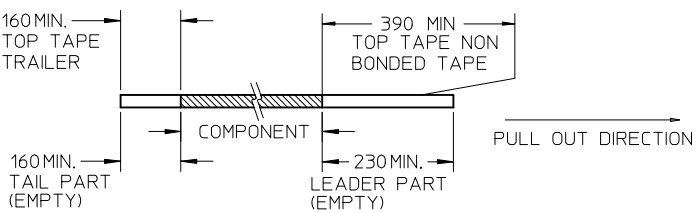

2. PEELING OFF FORCE OF THE TOP TAPE: 20 - 80gf. (PEELING DIRECTION AS SHOWN IN FOLLOWING FIGURE)

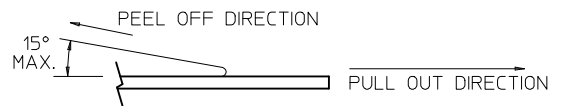

- 3. TAPE AND REEL SPECIFICATION IS AS PER EIA-481.
- 4. TAPE AND REEL QUANTITY : 200 PCS/ REEL.
- 5. THE TAPE IS TREATED FOR ANTI-STATIC.

ADD 15AU PART No. EC NO: S2009-0212 DRWN:VMANICKAM 2008/10/10 CHKD:CCTEH 2008/10/13 APPR:SHLENI 2008/10/13	DESCRIPTION QUALITY SYMBOLS ▽=0 ◻=0	GENERAL TOLERANCES (UNLESS SPECIFIED)		DIMENSION STYLE	SCALE	DESIGN UNITS	THIRD ANGLE PROJECTION	
				MM ONLY	NTS	METRIC		
		4 PLACES	± ---	± ---	DRAWN BY	DATE	TITLE	
		3 PLACES	± ---	± ---	DWLEE01	2007/08/31	DDR/DDR2 SO DIMM	
2 PLACES	± 0.2	± ---	CHECKED BY	DATE	200 CKTS, 5.2MM HEIGHT			
1 PLACE	± ---	± ---	VMANICKAM	2007/12/06	REVERSE ORIENTATION			
ANGULAR ± 1 °			APPROVED BY	DATE	MOLEX INCORPORATED			
DRAFT WHERE APPLICABLE MUST REMAIN WITHIN DIMENSIONS			SHLENI	2007/12/06	DOCUMENT NO. SD-78309-001			
			MATERIAL NO.		SHEET NO. 6 OF 6			
			SIZE A3	THIS DRAWING CONTAINS INFORMATION THAT IS PROPRIETARY TO MOLEX INCORPORATED AND SHOULD NOT BE USED WITHOUT WRITTEN PERMISSION				