



Chipsmall Limited consists of a professional team with an average of over 10 year of expertise in the distribution of electronic components. Based in Hongkong, we have already established firm and mutual-benefit business relationships with customers from,Europe,America and south Asia,supplying obsolete and hard-to-find components to meet their specific needs.

With the principle of "Quality Parts,Customers Priority,Honest Operation,and Considerate Service",our business mainly focus on the distribution of electronic components. Line cards we deal with include Microchip,ALPS,ROHM,Xilinx,Pulse,ON,Everlight and Freescale. Main products comprise IC,Modules,Potentiometer,IC Socket,Relay,Connector.Our parts cover such applications as commercial,industrial, and automotives areas.

We are looking forward to setting up business relationship with you and hope to provide you with the best service and solution. Let us make a better world for our industry!



## Contact us

Tel: +86-755-8981 8866 Fax: +86-755-8427 6832

Email & Skype: info@chipsmall.com Web: www.chipsmall.com

Address: A1208, Overseas Decoration Building, #122 Zhenhua RD., Futian, Shenzhen, China



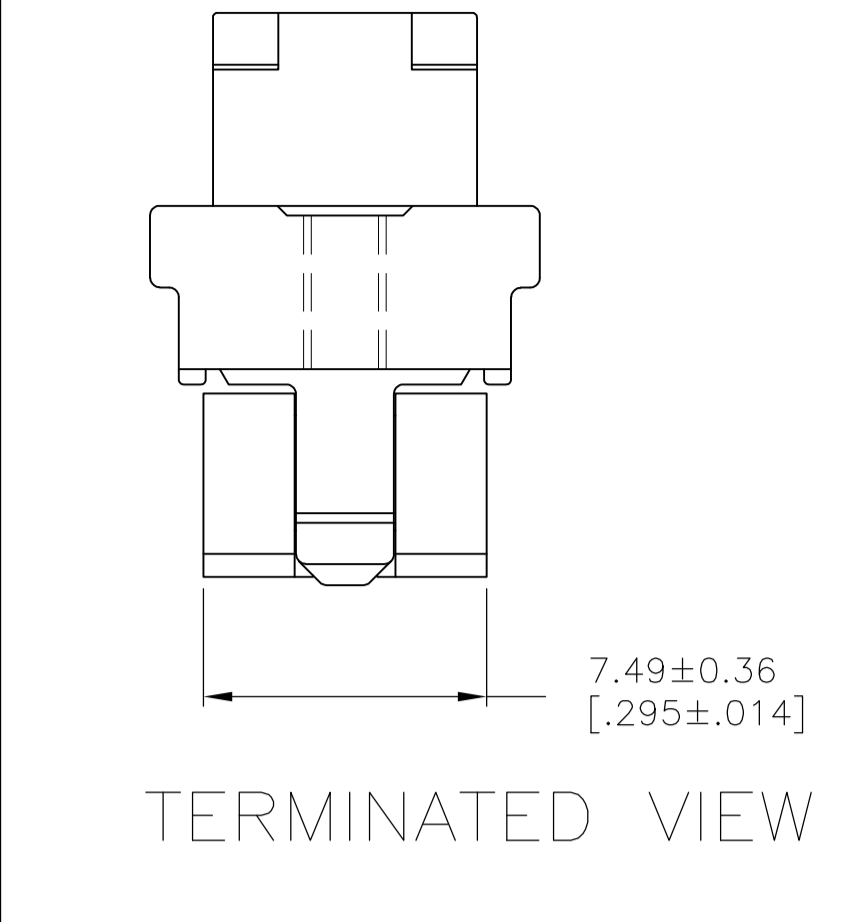
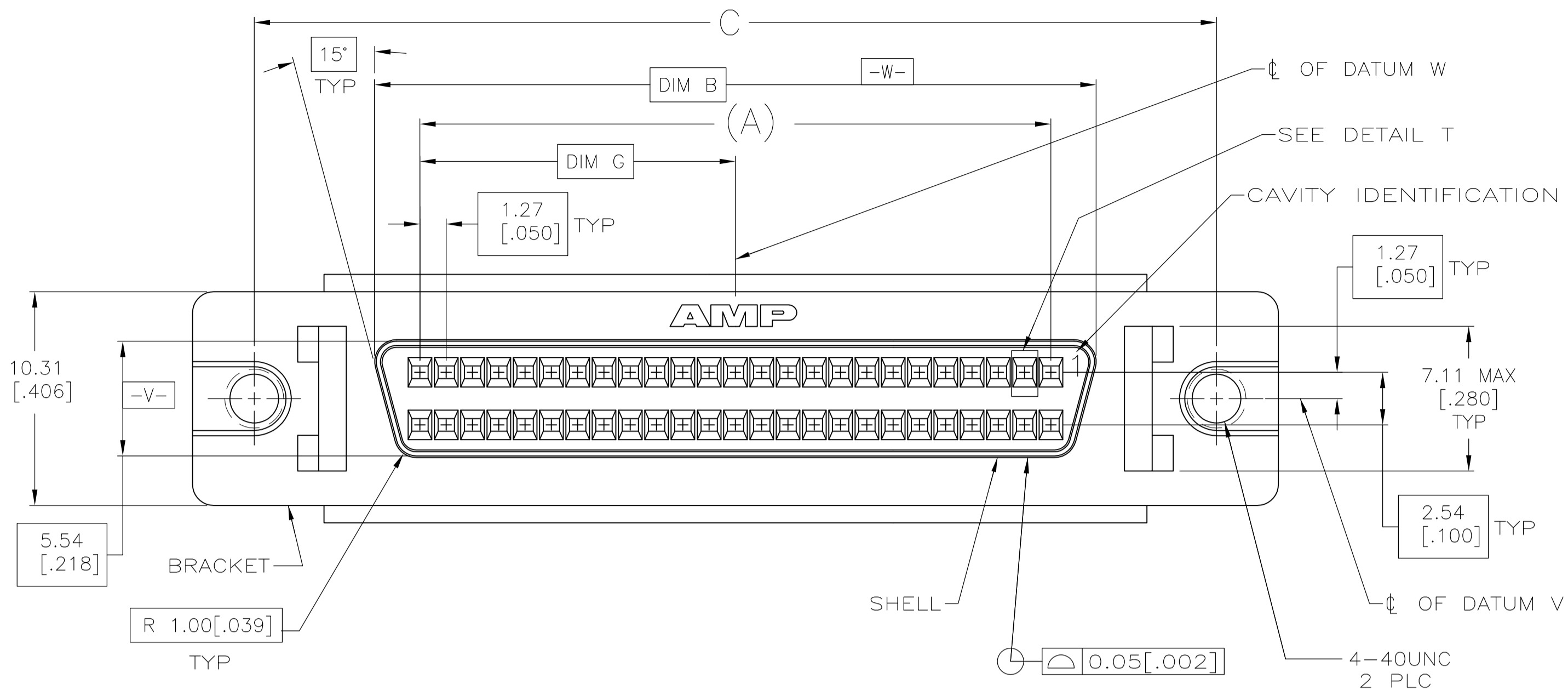

- 1 CONTACTS: PHOSPHOR BRONZE.  
SHELL: CARBON STEEL.  
HOUSING: POLYESTER, BLACK, UL 94V-0 RATED.  
TERMINATING COVERS: POLYESTER, UL 94V-0 RATED, COLOR: SEE TABLE.  
BRACKET: ZINC.
- 2 FINISH—  
SHELL: 5.08µm [.000200] MIN NICKEL OVER 1.27µm [.000050] MIN COPPER.  
BRACKET: 5.08µm [.000200] MIN NICKEL OVER 7.62µm [.000300] MIN COPPER.  
CONTACTS: SEE TABLE.
- 3 EITHER 0.76µm [.000030] MIN GOLD PLATE OR GOLD FLASH OVER PALLADIUM NICKEL PLATE,  
0.76µm [.000030] MIN TOTAL FOR A LENGTH OF 0.64 [.025] MIN, 0.13 [.005] MAX FROM  
MATING END, 1.27µm [.000050] MIN TIN-LEAD IN TERMINATION AREA, ALL OVER 1.27µm  
[.000050] MIN NICKEL.
- 4 EITHER 0.76µm [.000030] MIN GOLD PLATE OR GOLD FLASH OVER PALLADIUM NICKEL PLATE,  
0.76µm [.000030] MIN TOTAL FOR A LENGTH OF 0.64 [.025] MIN, 0.13 [.005] MAX FROM  
MATING END, 1.27µm [.000050] MIN MATTE TIN IN TERMINATION AREA, ALL OVER 1.27µm  
[.000050] MIN NICKEL.
- 5 RECOMMENDED WIRE: 28 AWG OR 30 AWG, SOLID OR 7 STRAND, PVC INSULATION, REFER TO  
TABLE BELOW FOR INSULATION DIA.
- 6. COVERS PACKAGED SEPARATE FROM CONNECTORS IN SAME SHIPPING CONTAINER.
- 7 OBSOLETE PART NUMBER.
- 8 ROHS 2002/95/EC COMPLIANT
- 9 OBSOLETE PARTS: OBSOLETE CIS STREAMLINING PER D.RENAUD/D.SINISI

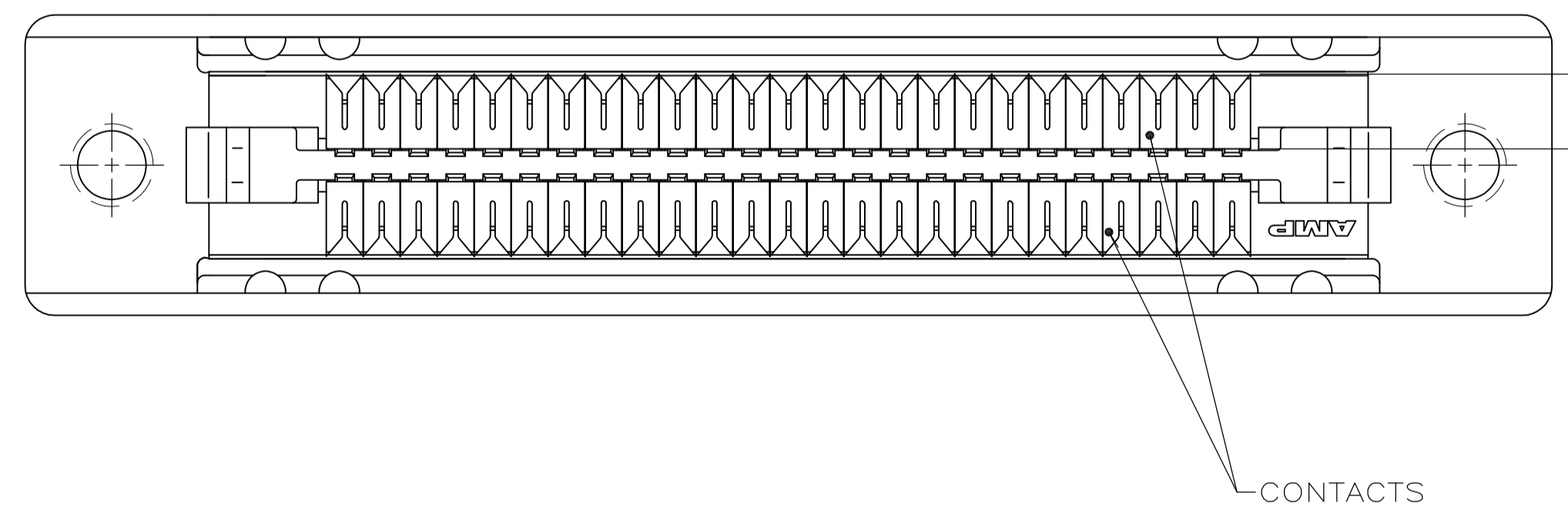
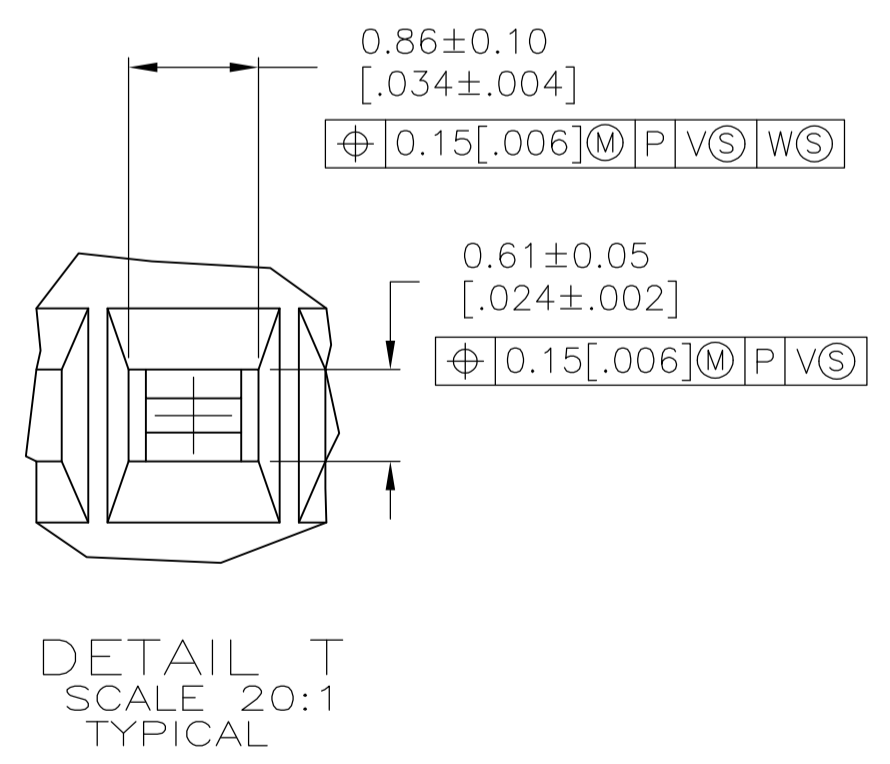
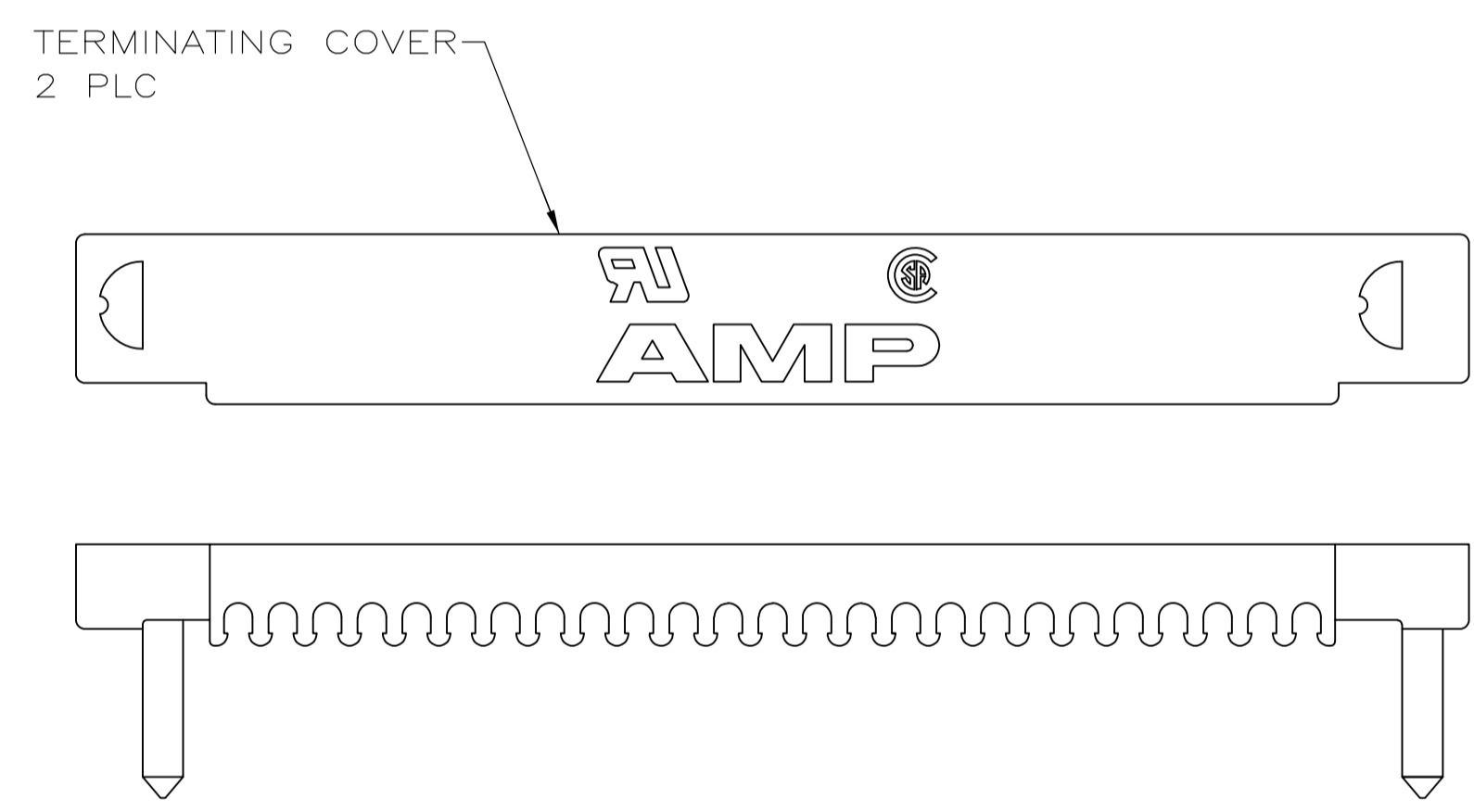
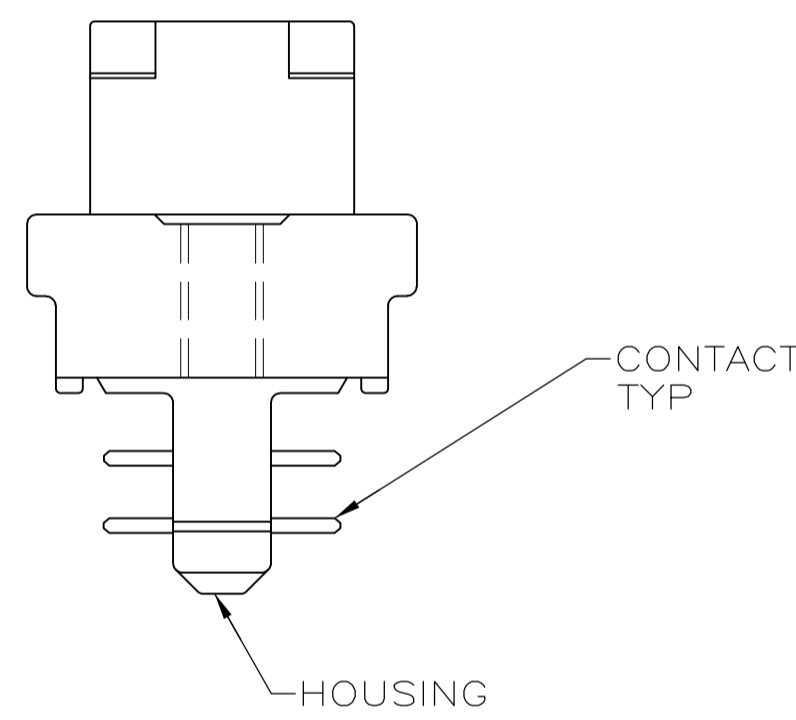
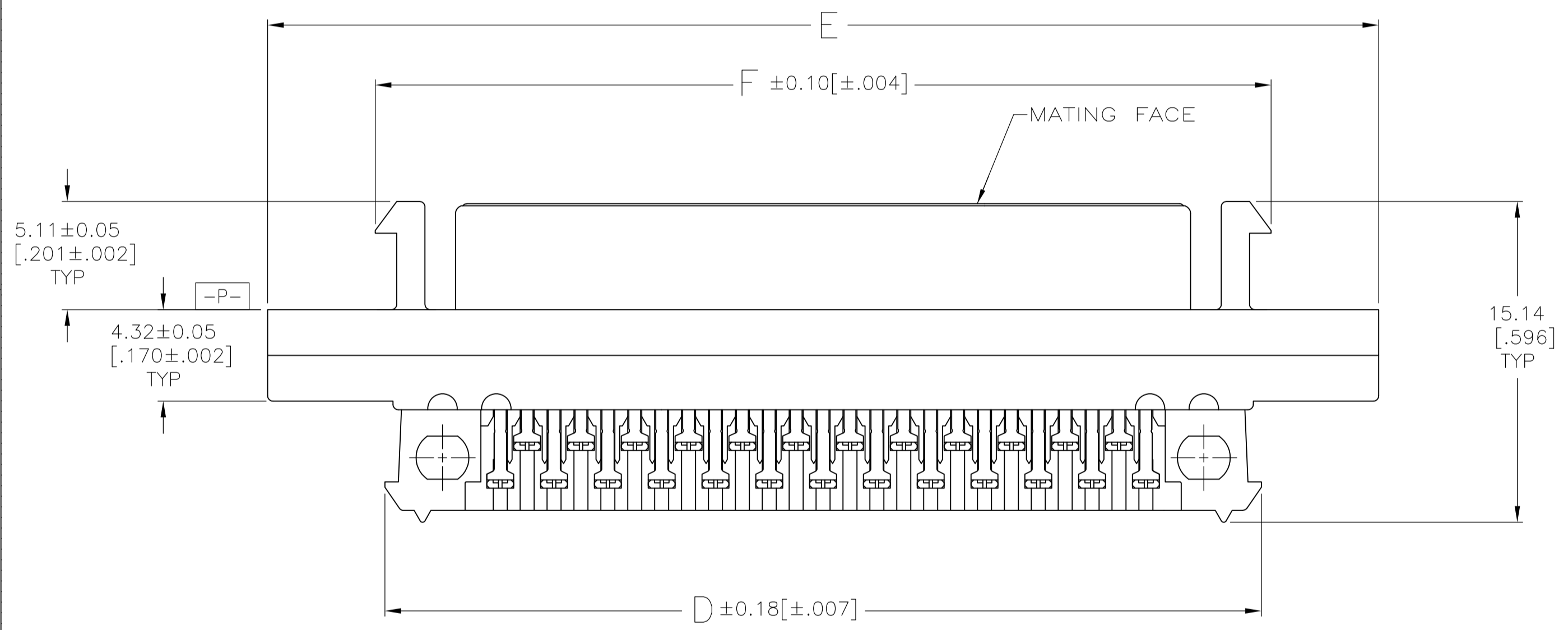

9/8	OBSOLETE	4	BLACK	0.81-0.91 DIA [.032-.036]	15.24 [.600]	42.29 [1.665]	52.45 [2.065]	41.38 [1.629]	46.48 [1.830]	34.70 [1.366]	30.48 [1.200]	50	5-786865-5	
	OBSOLETE	3	GRAY	0.74-0.79 DIA [.029-.031]	15.24 [.600]	42.29 [1.665]	52.45 [2.065]	41.38 [1.629]	46.48 [1.830]	34.70 [1.366]	30.48 [1.200]	50	1-786865-5	
		3	BLACK	0.81-0.91 DIA [.032-.036]	15.24 [.600]	42.29 [1.665]	52.45 [2.065]	41.38 [1.629]	46.48 [1.830]	34.70 [1.366]	30.48 [1.200]	50	786865-5	
	FINISH		TERMINATING COVERS COLOR	INSULATION OUTER DIA	5	G	F	E	D	C	B	A	NO OF POSN	PART NUMBER

THIS DRAWING IS A CONTROLLED DOCUMENT.

DIMENSIONS: mm [INCHES]	TOLERANCES UNLESS OTHERWISE SPECIFIED:	DIN C. OBERMAN 04/30/93	Tyco Electronics Corporation Harrisburg, PA 17105-3608
0 PLC ± -	1 PLC ± -	21SEP2007	RECEPTACLE KIT, UNASSEMBLED, PANEL MOUNT, W/ WIRE TERMINATING COVER, W/ LATCH BLOCK.
2 PLC ± 0.13 [.005]	3 PLC ± -	APVD J. OLSON 21SEP2007	
4 PLC ± -	ANGLES ± -	NAME J. OLSON	SIZE 108-1228
MATERIAL	FINISH	PRODUCT SPEC 114-40029	RESTRICTED TO
1	2	WEIGHT -	SCALE 5:1 SHEET 1 OF 1 REV J
CUSTOMER DRAWING		00779	786865