



Chipsmall Limited consists of a professional team with an average of over 10 year of expertise in the distribution of electronic components. Based in Hongkong, we have already established firm and mutual-benefit business relationships with customers from,Europe,America and south Asia,supplying obsolete and hard-to-find components to meet their specific needs.

With the principle of “Quality Parts,Customers Priority,Honest Operation,and Considerate Service”,our business mainly focus on the distribution of electronic components. Line cards we deal with include Microchip,ALPS,ROHM,Xilinx,Pulse,ON,Everlight and Freescale. Main products comprise IC,Modules,Potentiometer,IC Socket,Relay,Connector.Our parts cover such applications as commercial,industrial, and automotives areas.

We are looking forward to setting up business relationship with you and hope to provide you with the best service and solution. Let us make a better world for our industry!



Contact us

Tel: +86-755-8981 8866 Fax: +86-755-8427 6832

Email & Skype: info@chipsmall.com Web: www.chipsmall.com

Address: A1208, Overseas Decoration Building, #122 Zhenhua RD., Futian, Shenzhen, China



SERIES 78B Right Angle Option

FEATURES

- Easy Access
- SPST Circuitry
- 1-10 and 12 positions available
- Sealed versions available

APPLICATIONS

Telecommunications, computers and peripherals, instruments and controls.

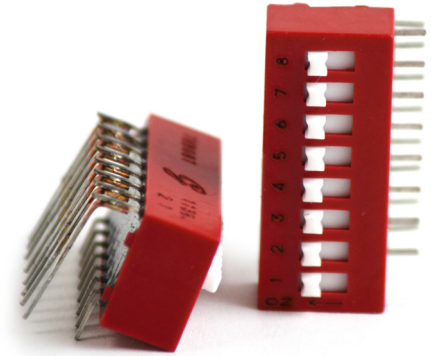

Series 78B DIMENSIONS in inches (and millimeters)

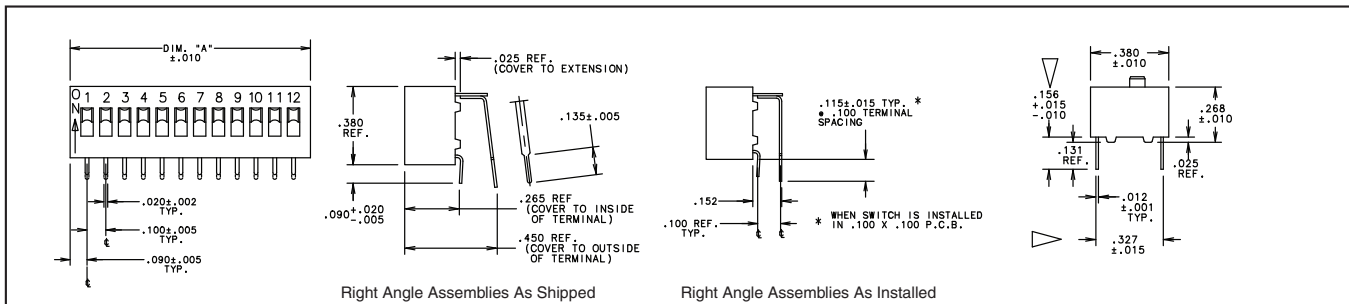

SPECIFICATIONS

Mechanical

Mechanical Life: 2,000 operations per switch.

Operation Temp: -40°C to + 85°C

Storage Temp: -55°C to + 85°C

Vibration Test: Per Method 204, Test Condition B, 1 mS opening (10 mS allowed)

Shock Test: MIL-STD-202F METHOD 213 Test Condition A, 1ms (10 allowed)

Electrical

Electrical Life: 10,000 operations per switch 24VDC, 25mA.

Non-Switching Rating: 100mA, 50VDC.

Switching rating: 150mA, 30VDC; 10mA, 50mVDC

Contact Resistance: 30mΩ max. at initial.

Insulation Resistance: (at 100VDC) 5,000MΩ min.

Dielectric Strength: 750VAC/1 minute.

Capacitance: 2pF max.

Soldering and Cleaning Process

*For the most current soldering & cleaning processing guidelines, reference Grayhill Dip Switch Processing Information, Bulletin 1234

Cleaning tape sealed products:

Passes immersion test using water/detergent. Acceptable solutions include 1-1-1 trichlorethane, freon, (TF, TE, or TMS), isopropyl alcohol, detergent (140°F maximum). Terpene acceptable for Series 90 only. Solutions which are not recommended include acetone, methylenechloride, freon TMC. Pressure wash cleaning processes are not recommended for tape seal switches.

Wave Soldering: Recommended solder temperature: 500°F (260C) max 5 seconds.

Hand Soldering: Use a soldering iron of 30 Watts or less, controlled at 608°F (320°C) approximately 2 seconds while applying solder.

Cleaning: Tape sealed versions withstand cleaning processes.

Materials

Contact Ball: Brass with gold plating over nickel

Terminals: Brass with gold plating over nickel

Nonconductive Parts: Plastic UL94V-0

Potting Material: Epoxy

Shorting Member (Ball): Brass, gold-plated over nickel barrier.

Protective Cover: Polycarbonate.

Tape Seal: Polyester film

Tape Seal Integrity: Passes gross leak test using 125°C flourinert for 20 seconds minimum. Reference MIL-STD-202, Method 112.

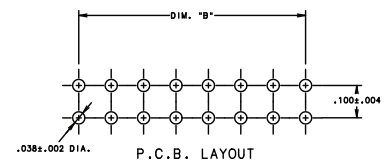
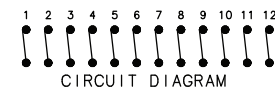

ORDERING INFORMATION

Series 78B, 78F, 78G, 78H, 78J, 78K, 78RB Styles available as right angle
Number of Positions 1 through 12 (depending on Series)
 RoHS compliant

78B08SRAT

Right Angle
S= Top Tape Sealed, Blank=Unsealed

