



Chipsmall Limited consists of a professional team with an average of over 10 year of expertise in the distribution of electronic components. Based in Hongkong, we have already established firm and mutual-benefit business relationships with customers from,Europe,America and south Asia,supplying obsolete and hard-to-find components to meet their specific needs.

With the principle of “Quality Parts,Customers Priority,Honest Operation,and Considerate Service”,our business mainly focus on the distribution of electronic components. Line cards we deal with include Microchip,ALPS,ROHM,Xilinx,Pulse,ON,Everlight and Freescale. Main products comprise IC,Modules,Potentiometer,IC Socket,Relay,Connector.Our parts cover such applications as commercial,industrial, and automotives areas.

We are looking forward to setting up business relationship with you and hope to provide you with the best service and solution. Let us make a better world for our industry!



Contact us

Tel: +86-755-8981 8866 Fax: +86-755-8427 6832

Email & Skype: info@chipsmall.com Web: www.chipsmall.com

Address: A1208, Overseas Decoration Building, #122 Zhenhua RD., Futian, Shenzhen, China



Static Monitor 790

Installation, Operation and Maintenance



Figure 1. SCS Static Monitor [790](#).

Description

The SCS Static Monitor 790 is designed to monitor the operation of two wrist strap grounding systems and the ground connection of a specified equipment chassis. This product has been designed and tested for indoor use only and with SCS Dual Conductor Wristbands 2300VM Series and SCS Dual Conductor Ground Cord 2300 Series. The monitor operates from a 120VAC adaptor that is included in the North America version. Outside North America, obtain an appropriate AC adapter meeting the specifications. The product has not been tested or proven safe for other uses.

Note: SCS Dual Conductor Cords & Wristbands 2300VM Series are required for use with the Static Monitor 790, ordered separately.

Meets requirements of ANSI/ESD S20.20 and recommendations of ESD Handbook ESD TR20.20 which includes "if the products that are being produced are of such value that knowledge of a continuous, reliable ground is needed, and then continuous monitoring should be considered or even required".

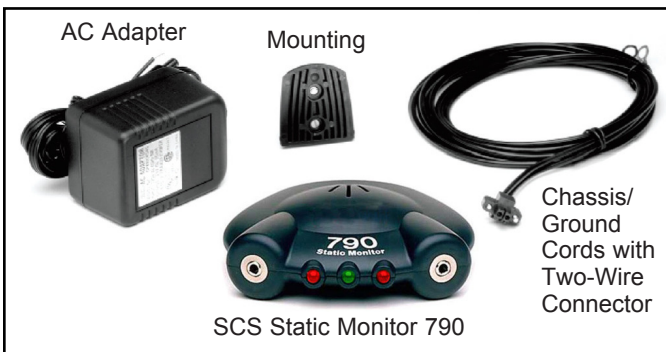

Figure 2. SCS Static Monitor [790](#) Kit.

Theory of Operation

The SCS Static Monitor 790 is designed to continuously monitor the voltage level on an operator(s) using a high impedance voltage measurement circuit. The measured operator's voltage is compared to one of four user selectable (1V, 3V, 6V and 9V) internal reference voltages. An alarm will sound with a corresponding red flashing lamp(s), when an operator's voltage level (caused by static generation) exceeds the selected internal reference voltage.* In addition, a wristband contact detection circuit is also employed to let the user know if the wristband is being worn improperly or has experienced a loss of continuity between the ground cord and wristband.

The ground connection of the Static Monitor 790 is continuously monitored through a low DC current-loop measurement circuit. The ground connection of an equipment chassis can also be monitored when connected in series with the monitor's ground measurement circuit. An alarm will sound with corresponding red lamps, when this loop resistance exceeds 10 ohms.**

If all monitored components are operating within the selected operating parameters of the Static Monitor 790, a green lamp will illuminate.

The Static Monitor 790 uses a modified version of the SCS Dual Conductor Wristband (VM Series) and the standard SCS Dual Conductor Grounding Cord (See Accessories Section).

*Voltage alarm levels $\pm 15\%$

**Ground disconnect $\pm 20\%$

CAUTION: The SCS Static Monitor 790 does not have the capability of verifying that the ground point is a suitable ground. If you are not sure what a suitable ground is, contact a licensed electrician before installation.

Attaching Ground and Chassis Cords

Tools required – Small blade screwdriver.

Refer to Figures 3 and 4 for this section.

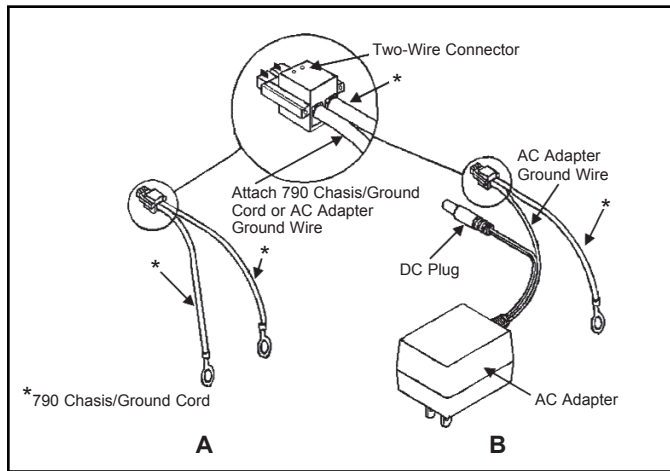

Figure 3. Attachment of Ground Cords.

Note: Perform Step #1 below when monitoring directly to the ground connection (Fig. 4A). Perform Step #2 when monitoring the ground connection through a grounded chassis (Fig. 4B).

Installation of Static Monitor 790 with Chassis Terminal Connected Directly to Earth/Electrical Ground

Determine how you want to ground the Static Monitor 790:

- a) If you are grounding the Static Monitor 790 through the 3-Wire AC adaptor (North America) supplied, perform the following steps:
 - Attach the tinned ground wire of the AC adaptor to the ground terminal of the two-wire connector by inserting it into the opening and securing with screwdriver.
 - Attach one of the supplied Static Monitor 790 Chassis/Ground Cords (tinned end) to the chassis terminal of the two-wire connector in the same manner.
 - Attach the ring terminal end of the Chassis/Ground Cord to an earth/electrical ground with a screw (not supplied).
 - Plug the two-wire connector into the jack at the rear of the Static Monitor 790.
- b) If you are grounding the SCS Static Monitor 790 through a Chassis/Ground Cord perform the following steps:
 - Attach one of the supplied Chassis/Ground Cords (tinned end) to the ground terminal of the two-wire connector by inserting it into the opening and securing with screwdriver.
 - Attach the other Chassis/Ground Cord to the chassis terminal of the two-wire connector in the same manner.

- Attach the ring terminal ends of both cords separately with two screws (not supplied) to an earth/electrical ground.
- Plug the two-wire connector into the jack at the rear of the Static Monitor 790.

CAUTION: When using two Chassis/Ground Cords, attach each of the cords to separate ground bonding points. By attaching the cords to the same ground but at different physical locations, the monitor can check for loose or lost connections.

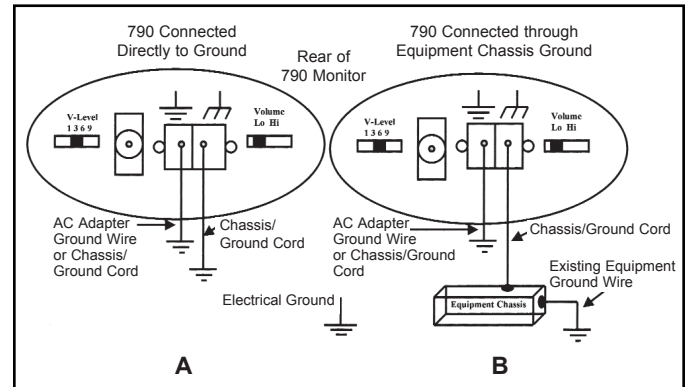

Figure 4. SCS Static Monitor 790 Connected Directly to Ground or Through Equipment Chassis Ground.

Installation of SCS Static Monitor 790 with Chassis Terminal Connected to a Grounded Equipment Chassis

Determine how you want to ground the Static Monitor 790:

- a) If you are grounding the Static Monitor 790 through the 3-wire AC adaptor supplied, perform the following steps:
 - Attach the tinned ground wire of the AC adaptor to the ground terminal of the two-wire connector by inserting it into the opening and securing with screwdriver.
 - Attach one of the supplied Chassis/Ground Cords (tinned end) to the chassis terminal of the two-wire connector in the same manner.
 - Attach the ring terminal end of the Chassis/Ground Cord to the equipment chassis with a screw (not supplied).
 - Plug the two-wire connector into the jack at the rear of the Static Monitor 790.
- b) If you are grounding the Static Monitor 790 through a Chassis/Ground Cord perform the following steps:
 - Attach one of the supplied Chassis/Ground Cords (tinned end) to the ground terminal of the two-wire connector by inserting it into the opening and securing with screwdriver.
 - Attach the other Chassis/Ground Cord to the chassis terminal of the two-wire connector in the same manner.

- Attach the ring terminal end of the Chassis/ Ground Cord connected to the ground terminal of the two-wire connector, with a screw (not supplied) to an earth/electrical ground.
- Attach the ring terminal end of the Chassis/ Ground Cord connected to the chassis ground terminal of the two-wire connector, with a screw (not supplied) to an equipment chassis.
- Plug the two-wire connector into the jack at the rear of the Static Monitor 790.

CAUTION: When using two Chassis/Ground Cords, attach each of the cords to separate ground bonding points. By attaching the cords to the same ground but at different physical locations, the monitor can check for loose or lost connections.

Attaching the SCS Static Monitor 790 to a Workbench or Equipment Chassis



Figure 5. Attachment of Mounting Plate to SCS Static Monitor 790.

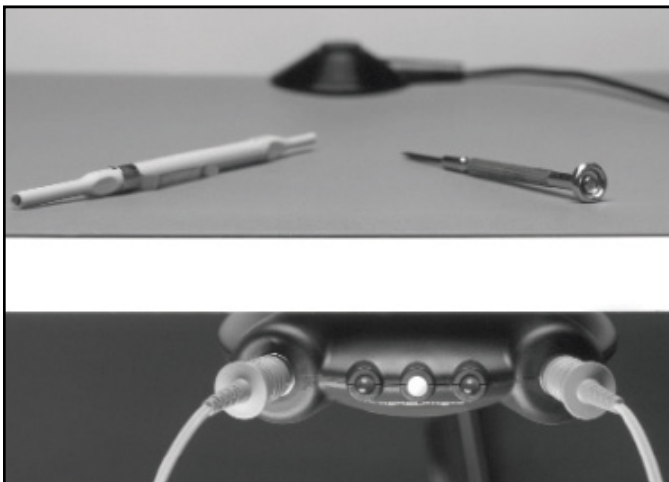

Figure 6. SCS Static Monitor 790 attached to workbench.

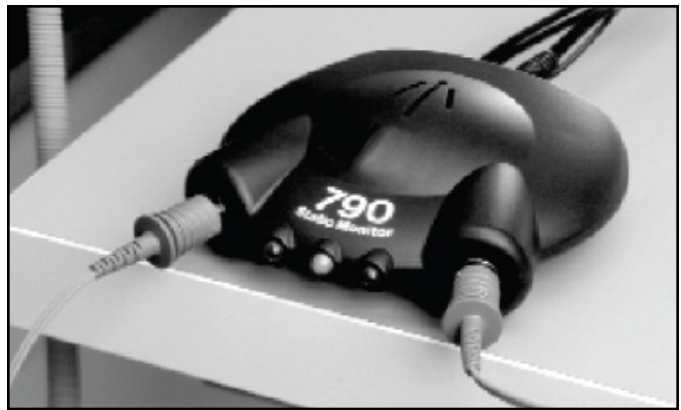

Figure 7. SCS Static Monitor 790 attached to equipment chassis.

Refer to Figures 5, 6, and 7

Locate the Mounting Plate.

- Attach the Mounting Plate in the desired location using one of the following methods:
 - a) Foam tape (already applied to the Mounting Plate). Clean the surface to be mounted to with isopropyl alcohol. Remove release liner from tape before mounting.
 - b) Two #8 pan head machine or wood screws (not supplied).
- Attach the Static Monitor 790 to the mounted plate as shown in Figure 5. Align the plate with the opening on the bottom of the monitor and slide forward onto plate until it latches.

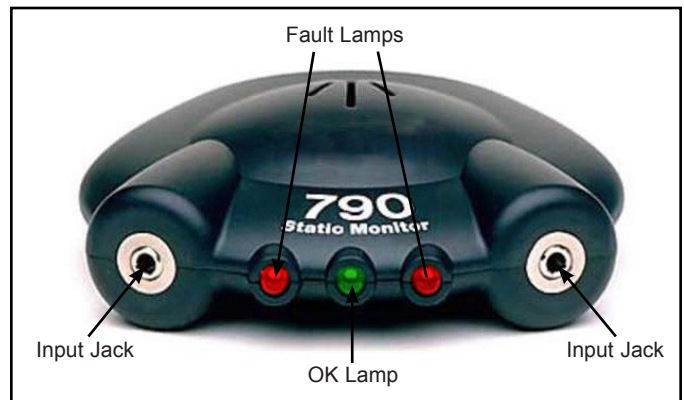

Figure 8. Front of SCS Static Monitor 790

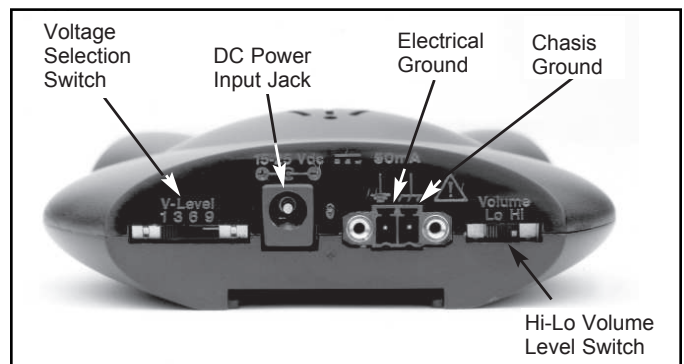

Figure 9. Rear of SCS Static Monitor 790.

Operating Your System

Refer to Figures 8 and 9

Power Up

Apply power to the SCS Static Monitor 790 by inserting the round connector on the end of the AC adaptor, into the jack at the rear of the Static Monitor 790. Plug the AC adaptor into an appropriate electrical outlet. The green lamp should illuminate, signaling that the unit is operational and that there are no alarm conditions. If the green lamp does not illuminate, but red lamps are illuminated with audible alarm sounding, check all cords and ground connections.

Audible Alarm Volume Level

Select the desired audible alarm volume level at the rear of the Static Monitor 790 by sliding the switch to the Hi or Lo position.

Selection of the Reference Voltage

The Static Monitor 790 allows for the selection of one of four internal reference voltages (1V, 3V, 6V and 9V) with 1V being the most sensitive setting and 9V the least sensitive. Select a voltage level by sliding the switch to the appropriate position. These ranges have been designed to accommodate global ESD requirements. The selection of this operational parameter is based upon the user's ESD control program requirements.

Fault Conditions – Lamps & Audible Alarms

For wrist strap malfunctions, the Static Monitor 790 indicates different alarms for each operator; a slow audible beep/flashing lamp for the operator on the left input side and a fast audible chirping beep/flashing lamp for the operator on the right input side. For grounding/chassis-monitoring malfunctions, a continuous tone is emitted with both lamps illuminated.

a) Red lamp(s) flashing with an audible alarm.

This alarm mode can be caused by two conditions and both are interrelated. If either the voltage level on the operator is greater than the pre-selected internal reference voltage or poor contact between the wristband and the arm exist, the alarm will activate.

If the SCS Static Monitor 790 alarm activates when the operator is not moving (normally a non-charging situation), the cause is most likely due to poor contact between the wristband and the arm. The alarming period would normally be long in duration (unless intermittent contact) during this type of condition. Check contact between the wristband and arm. Some operators may have difficulty in providing sufficient contact to the wristband because of dry skin or arm hair. They may need to use an approved skin moisturizer or reposition the wristband on the arm.

If the monitor's alarm does not activate while the operator is not moving, then the cause of the alarm was most likely due to a voltage being developed on

the operator. A high resistance between the operator and ground would allow the operator to charge up as they moved about. The alarm period for this type of fault would normally be short and coincide with their body movement.

Alarming can also be caused by an intermittent or high resistance in the wrist strap's dual conductor ground cord. Replace a suspect cord with a known good ground cord or check the end to end resistance of the cord using an ohmmeter. Approximately 1 megohm of resistance should exist between the tip to tip and barrel to barrel contacts of the two plugs located on opposite ends of the cord.

Note: The operators may complain that the alarm is sounding too often until they learn to adjust the wristband to fit securely or apply an approved skin moisturizer on a frequent basis. Please remember that the monitor is informing you that the operator is exceeding the established static control requirement for voltage to ground when wearing a static protective wrist strap assembly. These alarms alert the operator when sensitive electronics are possibly being exposed to static electricity. Prior to incorporating the static monitor into your static control process, the operator was unaware of these events.

b) Two red lamps illuminated (continuously) with an audible alarm. This indicates that a high resistance condition (greater than 10 ohms) exists between the Chassis/Ground Cord and ground. This will include the equipment chassis ground if being monitored. Check the ground cords for continuity and ground attachment points.

Connecting an Operator to the SCS Static Monitor 790

- Attach a SCS Dual Conductor Wristband to the arm and adjust the band for a snug fit, following the instructions received with the wristband.
- Insert a Dual Conductor Ground Cord (longer plug end) into either one of the input jacks located on the front of the Static Monitor 790. The wrist strap monitoring function is activated during this step. The green lamp extinguishes at this time and the corresponding red lamp will illuminate with an audible alarm.
- Insert the other end of the ground cord (shorter plug end) into the wristband socket. The red lamp and the audible alarm should be extinguished at this time.

Note: Following the attachment sequence above provides an operator(s) with a simple go-no-go test of the wrist strap function every time they connect to the Static Monitor 790.

Quick Review of Functions

- If the monitor's ground connection is maintained (including the chassis ground connection when monitored) and the operator's voltage is held below the pre-selected range, the cord, wristband, and contact to the arm of the wearer are all considered to be functioning correctly. At this time, the green lamp illuminates on the front of the monitor.
- If an operator(s) develops a voltage that exceeds the pre-selected voltage during normal work activities or the monitor loses its ground connection, the green lamp extinguishes, and red lamp(s) will illuminate with a corresponding audible alarm. This is an indication of an exceeded voltage condition on the operator, due to poor electrical contact between the arm and band or intermittent or broken ground cord.
- An operator's fault condition is easily identified by one of the two red lamps next to each input jack. The flashing red lamp(s) identifies the operator that is experiencing the fault condition. The red lamps and audible alarms flash and beep at different rates to help identify the location of the fault.

SCS Standby Jack 3057

Use of an optional Standby Jack 3057 at the workstation extends the life of the monitor's input jacks. The operator disconnects the ground cord from the wristband and plugs into the Standby Jack 3057 that is mounted at the workstation. Plugging into the Standby Jack 3057 prevents the Static Monitor 790 from continuously alarming when disconnected from the wristband.

Verification Procedure

This procedure verifies the positive/negative voltage detection levels and ground monitoring performance of the SCS Static Monitor 790 as stated in, Specifications section of this user guide.

Equipment Required – Supplied by User

- DC Power Supply (DCPS) with connecting wires. Output 0 to +10VDC minimum.
- DC Voltmeter (DCV) with digital display $\pm 1\%$ accuracy and test leads. Use of a voltmeter is only required if DCPS does not include a digital display.
- Resistance Substitution Box (RSB), 1 ohms to 12 ohms (minimum) $\pm 1\%$ or discrete resistors 8 and 12 ohms $\pm 1\%$ value.

SCS Verification Kit 790VK (Ordered Separately).

- SCS Dual Conductor Ground Cord 2360 (5').
- Two-wire male connector with 24" tinned lead-wires.
- Test wristband socket.

Procedure:

1. Ground Disconnect / Hi & Lo Audible Alarm Volume Level Functions Ground Disconnect Specification: 10 ohms $\pm 20\%$

- a) Connect the RSB to the two-wire male connector with 24" tinned lead-wires. Insert the two-wire male connector into the mating jack located at the rear of the monitor.
- b) Connect the AC adaptor supplied with the Static Monitor 790 to the 25VDC input power-jack located at the rear of the monitor and plug the AC adaptor into a wall outlet.
- c) Set the RSB as follows and observe all lamps and audible alarm:
8 ohms – Green lamp ON, Red lamps OFF, and audible alarm OFF.
12 ohms – Green lamp OFF, Red lamps both ON (Continuous illumination), and audible alarm ON (Continuous tone).

Note: Confirm Hi and Lo audible alarm volume levels during 12 ohms test condition by adjusting Hi & Lo slide switch located at the rear of the monitor while alarm is sounding.

2. Wrist Strap Function – Open Circuit Test

- a) Adjust the RSB connected to the two-wire male connector to 8 ohms or less to silence the Ground Disconnect alarm. The green lamp should be ON at this time.
- b) Connect the SCS Dual Conductor Cord (longer plug end) into one of the wrist strap inputs on the SCS Static Monitor 790. Leave the other end of the cord (shorter plug end) open circuited at this time. Verify that the green lamp is now OFF, red lamp nearest the wrist strap input being tested is flashing, and that the audible alarm is sounding.

Note: The red lamp on the left side of the monitor flashes at a slower rate than the lamp located on the right. Also the audible alarm will sound at the same rate as the indicating flashing red lamp(s). This function allows for identifying the fault location.

- c) Repeat this step for the other wrist strap input, verifying performance as stated above.

Voltage Level Test

V-Level Specification: 1V ($\pm 15\%$) & 3V, 6V, and 9V ($\pm 10\%$)

- d) Unplug the AC adaptor from the wall outlet.
- e) Adjust DCPS output to 0VDC.
- f) Connect a wire between the positive output terminal of the DCPS and to one of the back plates of the test wristband socket. Connect a wire between the common of the DCPS to the other back plate of the test wristband socket.

Note: Be careful not to cause a short condition between the two connecting wires.

- g) Insert the Dual Conductor Cord (shorter plug end) into the test wristband socket and the other end of the cord (longer plug end) into one of the wrist strap inputs on the front of the Static Monitor 790.
- h) Plug the AC adaptor into the wall-outlet.

Voltage Level Tolerances		
V-Level Switch	+15%	-15%
1V	1.15VDC	0.85VDC
3 V	3.45VDC	2.55VDC
6 V	6.9VDC	5.1VDC
9 V	10.35VDC	7.65VDC

- i) Select the 1V level (using a small tip tool) on the V-Level switch located at the rear of the monitor.
- j) Activate the output of the DCPS and adjust to 1.15VDC. Verify that the green lamp has turned OFF, red lamp nearest the wrist strap input being tested is flashing, and that the audible alarm is ON.

Note: The red lamp on the left side of the monitor flashes at a slower rate than the lamp located on the right. Also the audible alarm will sound at the same rate as the indicating flashing red lamp(s). This function allows for identifying the fault location.

- k) Adjust the DCPS to 0.85VDC. Verify that the green lamp is ON, red lamp nearest the wrist strap input being tested is OFF, and that the audible alarm is OFF.
- l) Repeat steps (J & K), however, now adjusting the SCS Static Monitor 790 for V-Levels of 3, 6, and 9VDC and the DCPS to the appropriate voltage level tolerances as stated in the above table. Alarm indications will follow as stated in the 1V level check.
- m) Repeat steps (J - L) using the other wrist strap input on the SCS Static Monitor 790, verifying performance as stated above.
- n) Change voltage polarity to the wristband test socket by reversing the wires previously connected in step f. above at the test socket or at the output terminals of the DCPS and verify performance repeating steps (I - M).

Specifications

Dimensions	1.25" H x 4.0" W x 3.5" D (31.8 mm x 101.6 mm x 88.9 mm)
Weight	3 oz. (84 g)
Power Supply Requirements*	Input: 120 VAC \pm 10% (North America) Outside North America (As required) Output: 25 VDC @ 50 mA rated load Output Plug Polarization: Center Negative Output Plug Dimensions: 5.5 mm O.D. x 2.1 mm I.D. x 10 mm Length
Accuracy	The following parameters are valid for altitudes up to 2000 m. Pollution degree 2, Class 3, Equipment: Voltage Detection Levels: 1V \pm 15%; 3V, 6V, and 9V \pm 10% Ground Disconnect: 10 ohms \pm 20% Environmental Operating Conditions: Temperature: Maximum 104°F, (40°C) Minimum 50°F (10°C) Humidity: Maximum 75% R.H.

*Reference: Helms-Man Industrial Co. Ltd. Model No. DPX411454G

CAUTION: Purchased power supply must have all local required regulatory certifications. Line voltage within the power supply shall be isolated from low voltage by double or reinforced insulation. The AC adaptor is required to operate the Static Monitor 790. If the ground wire of the AC adaptor is not used, it is recommended that the wire be taped back onto the main cable of the AC adaptor using electrical tape.

Parts Included

- 1 ea. SCS Static Monitor 790
- 1 ea. User's Guide
- 1 ea. Mounting Plate with Removable Foam Tape
- 1 ea. AC Adaptor
- 2 ea. Chassis/Ground Cords
- 1 ea. Two-wire Connector

Required Accessories and Optional Available Parts

Item	Description	Size
2368VM	SCS Dual Conductor Fabric Wristband	Adjustable
2360	SCS Dual Conductor Coil Cord	5' (1.5m)
2370	SCS Dual Conductor Coil Cord	10' (3m)
2371	SCS Dual Conductor Coil Cord	20' (6.1m)
3057	SCS Stand-By Jack	1.9" x 1.3" x 1.1" (4.8 x 3.3 x 2.8cm)
790VK	SCS Verification Kit	
724P	SCS Power Supply Replacement AC Adapter	

Regulatory Information

China RoHS

Electronic Industry Standard of the People's Republic of China, SJ/T11363-2006, Requirements for Concentration Limits for Certain Hazardous Substances in Electronic Information Products.



This symbol, per Marking for the Control of Pollution Caused by Electronic Information Products, SJ/T11364-2006, means that the product or part does contain a substance, as detailed in the chart below, in excess of the following maximum concentration values in any homogeneous material: (a) 0.1% (by weight) for lead, mercury, hexavalent chromium, polybrominated biphenyls or polybrominated diphenyl ethers; or (b) 0.01% (by weight) for cadmium. Unless otherwise stated by SCS in writing, this information represents SCS's best knowledge and belief based upon information provided by third party suppliers to SCS.

This numerical reference should not be construed as a representation regarding the product's life or an extension of a product warranty. In the event any product is proven not to conform with SCS's Regulatory Information Sheet, then SCS's entire liability and buyer's exclusive remedy, will be at SCS's option either: (i) replacement of product with a conforming product, or (ii) refund of the purchase price paid by buyer for each nonconforming product, within a reasonable time after written notification of said nonconformance and return of said product to SCS. SCS shall not under any circumstances be liable for direct, incidental, special, or consequential damages (including but not limited to loss of profits, revenue, or business) related to or arising out of this certification, including, the use, misuse or inability to use the product. Unless stated otherwise in writing,

the foregoing language cannot be waived, modified, or supplemented in any manner whatsoever.

WEEE Statement

The following information is only for EU-member States: The mark shown to the right is in compliance with Waste Electrical and Electronic Equipment Directive 2002/96/EC (WEEE). The mark indicates the requirement NOT to dispose the equipment as unsorted municipal waste, but use the return and collection systems according to local law.

cULus Statement

Meets UL Safety Requirements.

FCC

Note: This equipment has been tested and found to comply with the limits for a Class A digital device, pursuant to Part 15 of the FCC Rules. These limits are designed to provide a reasonable protection against harmful interference when the equipment is operated in a commercial environment. This equipment generates, uses, and can radiate radio frequency energy and, if not installed and used in accordance with the instruction manual, may cause harmful interference to radio communications. Operation of this equipment in a residential area is likely to cause harmful interference in which case the user will be required to correct the interference at their own expense.

Note: Modifications to this device shall not be made without the written consent of SCS. Unauthorized modifications may void the authority granted under Federal Communication Rules and Industry Canada Rules permitting the operation of this device.

This device complies with Part 15 of the FCC Rules. Operation is subject to the following two conditions: (1) this device may not cause harmful interference, and (2) this device must accept any interference received, including interference that may cause undesired operation.

ICES Statement

This Class A digital apparatus meets all requirements of the Canadian Interference-Causing Equipment Regulations.

Cet appareil numérique de la classe A respecte toutes les exigences du Règlement sur le matériel brouilleur du Canada.

Made in China

Limited Warranty, Warranty Exclusions, Limit of Liability and RMA Request Instructions

See the SCS Warranty -

<http://staticcontrol.descoindustries.com/warranty.aspx>