



Chipsmall Limited consists of a professional team with an average of over 10 year of expertise in the distribution of electronic components. Based in Hongkong, we have already established firm and mutual-benefit business relationships with customers from,Europe,America and south Asia,supplying obsolete and hard-to-find components to meet their specific needs.

With the principle of “Quality Parts,Customers Priority,Honest Operation,and Considerate Service”,our business mainly focus on the distribution of electronic components. Line cards we deal with include Microchip,ALPS,ROHM,Xilinx,Pulse,ON,Everlight and Freescale. Main products comprise IC,Modules,Potentiometer,IC Socket,Relay,Connector.Our parts cover such applications as commercial,industrial, and automotives areas.

We are looking forward to setting up business relationship with you and hope to provide you with the best service and solution. Let us make a better world for our industry!



Contact us

Tel: +86-755-8981 8866 Fax: +86-755-8427 6832

Email & Skype: info@chipsmall.com Web: www.chipsmall.com

Address: A1208, Overseas Decoration Building, #122 Zhenhua RD., Futian, Shenzhen, China



J-Link Supply Adapter

The J-Link Supply Adapter provides a fixed I/O voltage level for V_{TRef} . It eliminates the need to connect V_{TRef} (pin1) to the target.

In general, the target provides its I/O voltage level (V_{TRef}) on pin 1 to the debug probe insuring the debug probe uses the right I/O voltages and avoiding damage of the target debug pins. If signal V_{TRef} is not desired on the target board it can be omitted by using the J-Link Supply Adapter, manually setting the I/O voltage. Default I/O voltage is 3.3 V. For increased flexibility the J-Link Supply Adapter can adapt to other target voltages in the range from 1.2 V to 5.0 V by replacing a single resistor on the adapter.

The Supply Adapter can be inserted between J-Link and the target maintaining a 1:1 connection of all debug signals (except V_{TRef} /pin 1). It has a standard 20-pin 0.1" socket towards the J-Link debug probe and a standard 20-pin 0.1" header on the target side. The main reason for using the adapter is to reduce the number of connections to the target, especially in production environments. It can also be used with Flasher ARM. For dual wire debug interfaces such as SWD, typically only 3 wires are still required: SWDIO and SWDCLK as well as GND. For single wire interfaces such as SPD, the number of connections is reduced to 2 accordingly.

The J-Link Supply Adapter is compatible with [J-Link BASE](#), [J-Link PRO](#), [J-Link ULTRA+](#), [J-Link PLUS](#) and [Flasher ARM](#).

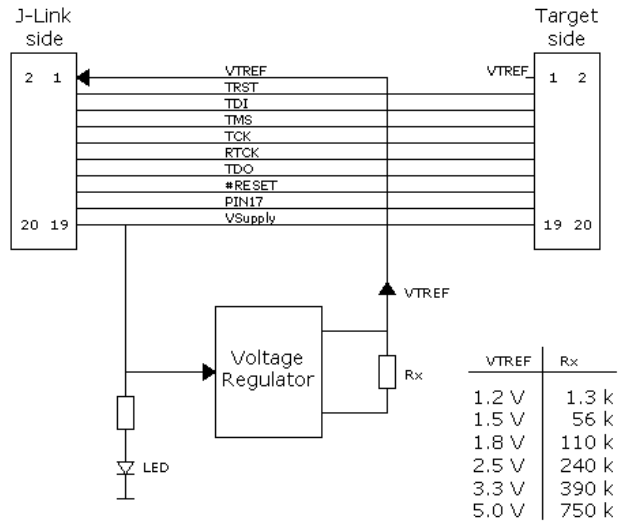
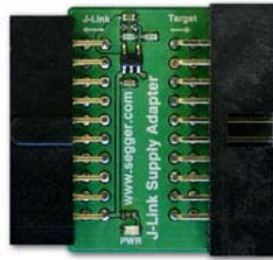

Block diagram of the J-Link Supply Adapter