



Chipsmall Limited consists of a professional team with an average of over 10 year of expertise in the distribution of electronic components. Based in Hongkong, we have already established firm and mutual-benefit business relationships with customers from,Europe,America and south Asia,supplying obsolete and hard-to-find components to meet their specific needs.

With the principle of “Quality Parts,Customers Priority,Honest Operation,and Considerate Service”,our business mainly focus on the distribution of electronic components. Line cards we deal with include Microchip,ALPS,ROHM,Xilinx,Pulse,ON,Everlight and Freescale. Main products comprise IC,Modules,Potentiometer,IC Socket,Relay,Connector.Our parts cover such applications as commercial,industrial, and automotives areas.

We are looking forward to setting up business relationship with you and hope to provide you with the best service and solution. Let us make a better world for our industry!



Contact us

Tel: +86-755-8981 8866 Fax: +86-755-8427 6832

Email & Skype: info@chipsmall.com Web: www.chipsmall.com

Address: A1208, Overseas Decoration Building, #122 Zhenhua RD., Futian, Shenzhen, China



THIS DRAWING IS UNPUBLISHED. RELEASED FOR PUBLICATION AUG, 2006.
 © COPYRIGHT BY TYCO ELECTRONICS CORPORATION. ALL RIGHTS RESERVED.

LOC	DIST	REVISIONS					
DW		P	LTR	DESCRIPTION	DATE	DWN	APVD
		G		REVISED PER ECR-16-003830	14MAR16	FL	SY

WEIGHT(g)	PCI-E COMPLIANCE	HOUSING MATERIAL	DIM. L	DIM. E	DIM. D	DIM. C	DIM. B	DIM. A	POS.	HOUSING COLOR	MIN. GOLD THICKNESS	PART NUMBER
8.7	GEN II & GEN III	PA9T	2.30	71.35	70	73.15	89	71.65	164	BLACK	15u"	4-1734774-8
5.45										WHITE	G/F	4-1734774-7
3.85				BLACK	15u"	4-1734774-6						
2.55				WHITE	G/F	4-1734774-5						
8.7				BLACK	15u"	4-1734774-4						
				WHITE	G/F	4-1734774-3						
				BLACK	15u"	4-1734774-2						
				WHITE	G/F	4-1734774-1						
5.45				BLACK	15u"	3-1734774-6						
				WHITE	G/F	3-1734774-5						
				BLACK	15u"	3-1734774-4						
				WHITE	G/F	3-1734774-3						
3.85			BLACK	15u"	3-1734774-2							
			WHITE	G/F	3-1734774-1							
			BLACK	15u"	3-1734774-0							
			WHITE	G/F	2-1734774-9							
2.55			BLACK	15u"	2-1734774-8							
			WHITE	G/F	2-1734774-7							
			BLACK	15u"	2-1734774-6							
			WHITE	G/F	2-1734774-5							
3.10			BLACK	15u"	2-1734774-4							
			WHITE	G/F	2-1734774-3							
			BLACK	15u"	2-1734774-2							
			WHITE	G/F	2-1734774-1							
	BLACK	15u"	2-1734774-0									
	WHITE	G/F	1-1734774-9									
	BLACK	15u"	1-1734774-8									
	WHITE	G/F	1-1734774-7									
	BLACK	15u"	1-1734774-6									
	WHITE	G/F	1-1734774-5									
	BLACK	15u"	1-1734774-4									
	WHITE	G/F	1-1734774-3									
8.7	BLACK	15u"	1-1734774-2									
	WHITE	G/F	1-1734774-1									
	BLACK	15u"	1-1734774-0									
	WHITE	G/F	1734774-9									
5.45	BLACK	15u"	1734774-8									
	WHITE	G/F	1734774-7									
	BLACK	15u"	1734774-6									
	WHITE	G/F	1734774-5									
3.85	BLACK	15u"	1734774-4									
	WHITE	G/F	1734774-3									
	BLACK	15u"	1734774-2									
	WHITE	G/F	1734774-1									

WEIGHT(g)	PCI-E COMPLIANCE	HOUSING MATERIAL	DIM. L	DIM. E	DIM. D	DIM. C	DIM. B	DIM. A	POS.	HOUSING COLOR	MIN. GOLD THICKNESS	PART NUMBER
8.8	GEN II	PA46	2.30	71.35	70	73.15	89	71.65	164	BLACK	15u"	9-1734774-7
5.5										WHITE	G/F	9-1734774-6
3.9				BLACK	15u"	9-1734774-5						
2.55				WHITE	G/F	9-1734774-4						
8.8				BLACK	15u"	9-1734774-3						
				WHITE	G/F	9-1734774-2						
				BLACK	15u"	9-1734774-1						
				WHITE	G/F	9-1734774-0						
5.5				BLACK	15u"	8-1734774-9						
				WHITE	G/F	8-1734774-8						
				BLACK	15u"	8-1734774-7						
				WHITE	G/F	8-1734774-6						
3.9			BLACK	15u"	8-1734774-5							
			WHITE	G/F	8-1734774-4							
			BLACK	15u"	8-1734774-3							
			WHITE	G/F	8-1734774-2							
2.55			BLACK	15u"	8-1734774-1							
			WHITE	G/F	8-1734774-0							
			BLACK	15u"	7-1734774-9							
			WHITE	G/F	7-1734774-8							
3.10			BLACK	15u"	7-1734774-7							
			WHITE	G/F	7-1734774-6							
			BLACK	15u"	7-1734774-5							
			WHITE	G/F	7-1734774-4							
	BLACK	15u"	7-1734774-3									
	WHITE	G/F	7-1734774-2									
	BLACK	15u"	7-1734774-1									
	WHITE	G/F	7-1734774-0									
	BLACK	15u"	6-1734774-9									
	WHITE	G/F	6-1734774-8									
	BLACK	15u"	6-1734774-7									
	WHITE	G/F	6-1734774-6									
8.8	BLACK	15u"	6-1734774-5									
	WHITE	G/F	6-1734774-4									
	BLACK	15u"	6-1734774-3									
	WHITE	G/F	6-1734774-2									
5.5	BLACK	15u"	6-1734774-1									
	WHITE	G/F	6-1734774-0									
	BLACK	15u"	5-1734774-9									
	WHITE	G/F	5-1734774-8									
3.9	BLACK	15u"	5-1734774-7									
	WHITE	G/F	5-1734774-6									
	BLACK	15u"	5-1734774-5									
	WHITE	G/F	5-1734774-4									
2.55	BLACK	15u"	5-1734774-3									
	WHITE	G/F	5-1734774-2									
	BLACK	15u"	5-1734774-1									
	WHITE	G/F	5-1734774-0									

THIS DRAWING IS A CONTROLLED DOCUMENT.

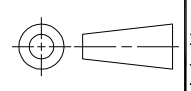
DIMENSIONS: MM	TOLERANCES UNLESS OTHERWISE SPECIFIED:	DWN B. HSING 15JUL2009	 TE Connectivity PCI EXPRESS CARD EDGE CONNECTOR VERTICAL, DIP TYPE, 3GIO
	0 PLC ± -	CHK S. CHIEN 15JUL2009	
	1 PLC ± 0.3	APVD W. KODAMA 15JUL2009	
MATERIAL	2 PLC ± 0.2	NAME	
	3 PLC ± 0.15	PRODUCT SPEC	
	4 PLC ± -	APPLICATION SPEC	
	ANGLES ± 3'	WEIGHT	
		CUSTOMER DRAWING	SIZE A3 CAGE CODE 00779 DRAWING NO C-1734774 RESTRICTED TO SCALE SHEET 1 OF 5 REV G

THIS DRAWING IS UNPUBLISHED. RELEASED FOR PUBLICATION AUG ,2006.
 © COPYRIGHT BY TYCO ELECTRONICS CORPORATION. ALL RIGHTS RESERVED.

LOC		DIST		REVISIONS				
P	LTR	DESCRIPTION			DATE	DWN	APVD	
		SEE SHEET 1						

- NOTES:
- MATERIAL:
 - HOUSING: 1.PA46 WITH 40% G.F, UL94 V-0, COLOR: SEE TABLE.
2.PA9T WITH 30% GF, UL94 V-0, COLOR: SEE TABLE.
 - CONTACT: PHOSPHOR BRONZE
 - FINISH:

CONTACT: (SEE TABLE) GOLD PLATING ON CONTACT AREA.
2.54um [100u"] MIN. MATTE-TIN PALTING ON SOLDER TAIL AREA.
1.27um [50u"] MIN. NICKEL UNDERPLATING OVERALL.
 - CONNECTOR HAS MET THE REQUIREMENTS PER PCI EXPRESS GEN 2 TECHNICAL DOCUMENT.
 - WEIGHT:

36 POS.: 2.55 GRAMS; 64 POS.: 3.90 GRAMS
98 POS.: 5.50 GRAMS; 164 POS.: 8.80 GRAMS
 - WAVE SOLDER CAPABLE TO 265°C PER TEST SPEC. 109-202 CONDITION B.
 ⚠️ REFLOW SOLDER CAPABLE TO 260°C PER TEST SPEC. 109-201 CONDITION B.
 (REFLOW SOLDERING PLEASE USE PN : 1734774-1 TO 4-1734774-8)

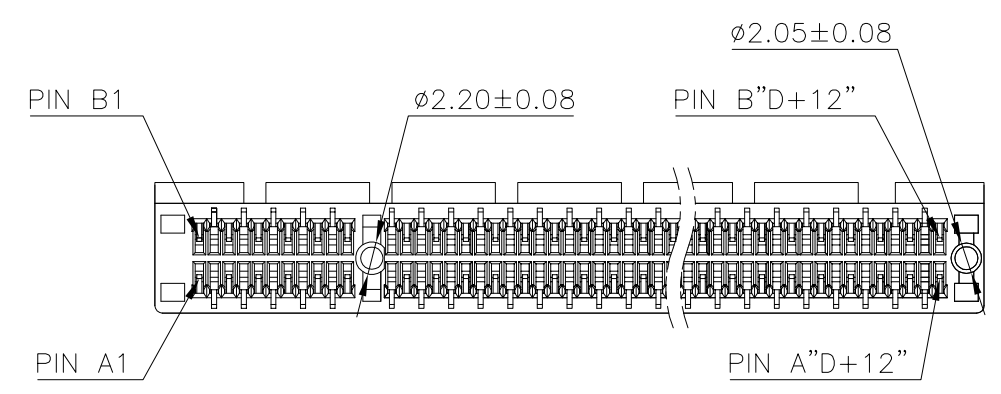
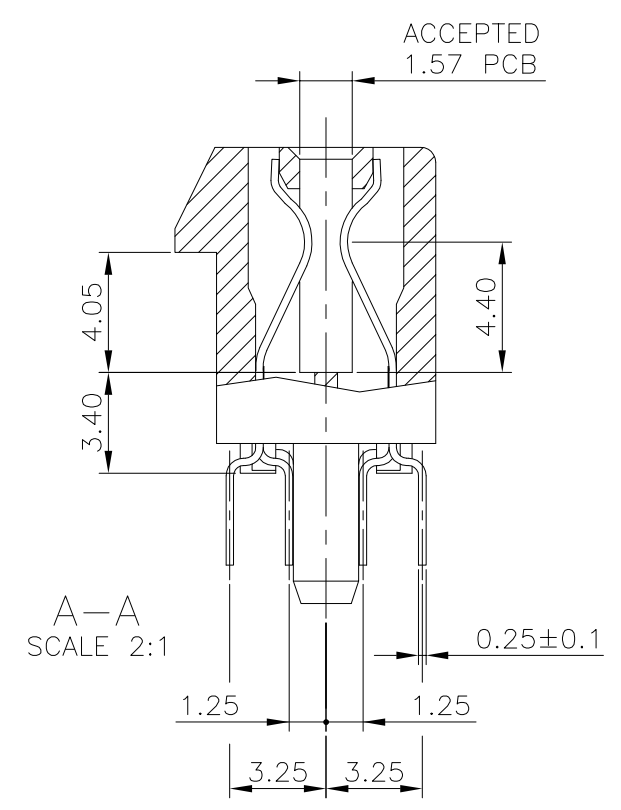
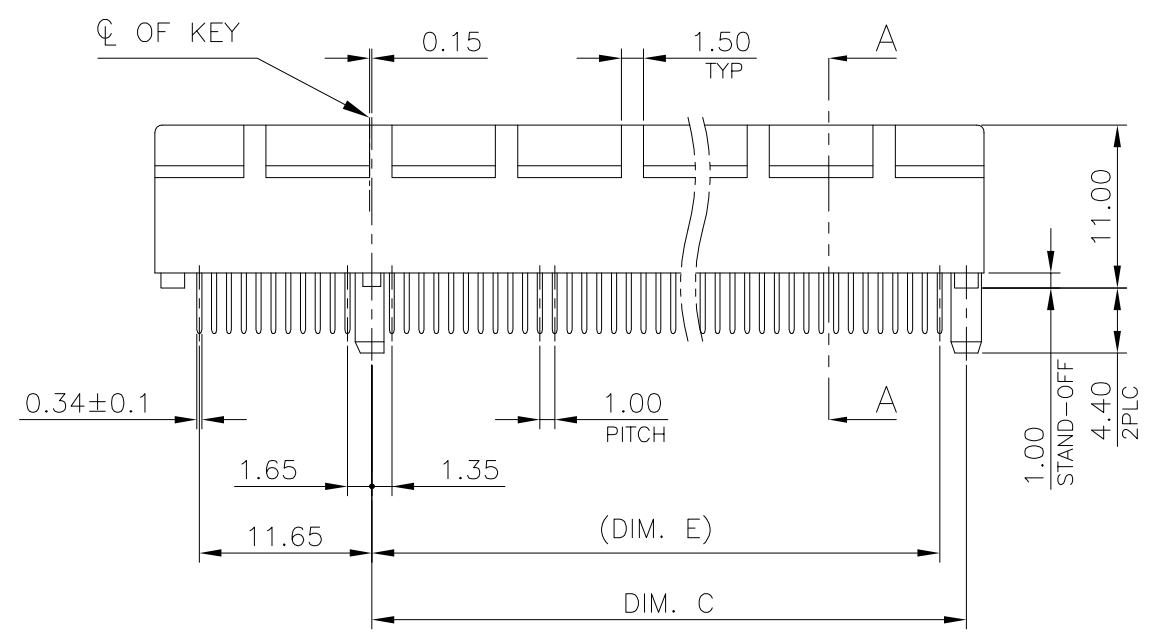
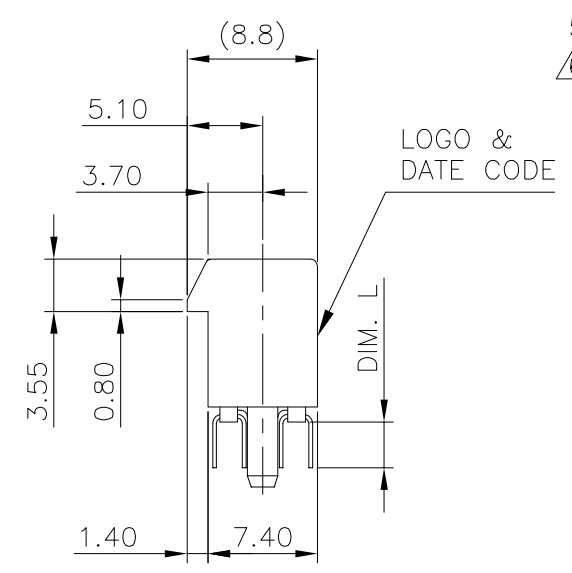
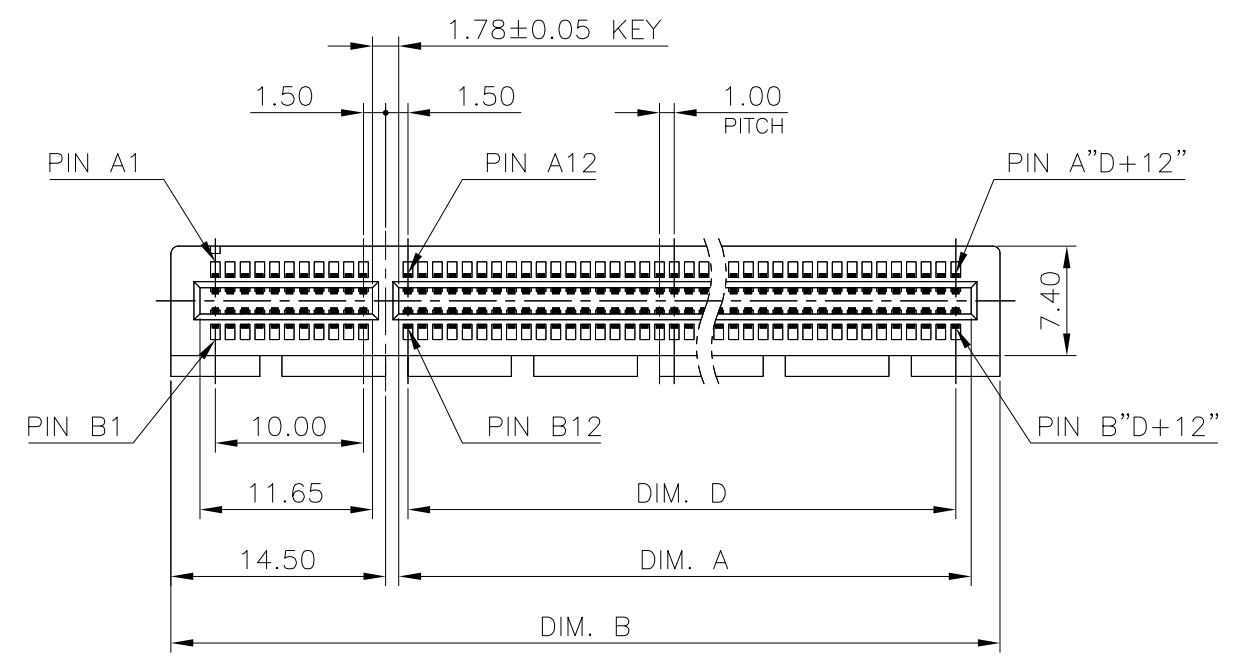

THIS DRAWING IS A CONTROLLED DOCUMENT.		DWN	TE Connectivity		
DIMENSIONS: MM		CHK	NAME		
TOLERANCES UNLESS OTHERWISE SPECIFIED:		APVD	PCI EXPRESS CARD EDGE CONNECTOR VERTICAL, DIP TYPE, 3GIO		
0 PLC ± -		PRODUCT SPEC	SIZE	CAGE CODE	DRAWING NO
1 PLC ± 0.3		APPLICATION SPEC	A3	00779	1734774
2 PLC ± 0.2		WEIGHT	RESTRICTED TO		
3 PLC ± 0.15		SEE NOTE 4	-		
4 PLC ± -		CUSTOMER DRAWING	SCALE	SHEET	REV
ANGLES ± 3'			-	2 OF 5	G
MATERIAL	FINISH				
SEE NOTE	SEE NOTE				

4

3

2

1

THIS DRAWING IS UNPUBLISHED. RELEASED FOR PUBLICATION AUG ,2006.
 © COPYRIGHT BY TYCO ELECTRONICS CORPORATION. ALL RIGHTS RESERVED.

LOC	DIST	REVISIONS			
P	LTR	DESCRIPTION	DATE	DWN	APVD
		SEE SHEET 1.			

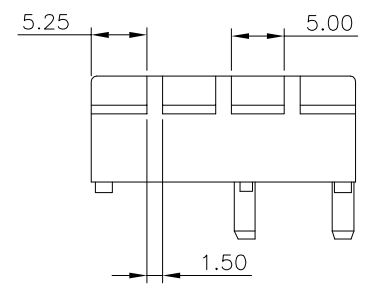

PN X-1 TO 4-X-8
(PA9T TYPE)

36 POS.

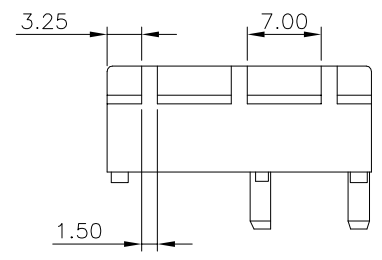

PN 5-X-0 TO 9-X-7
(PA46 TYPE)

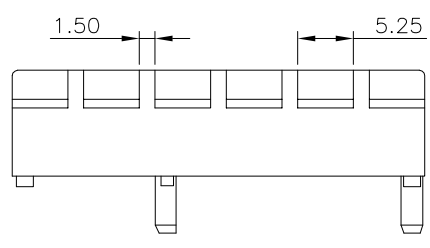

64 POS.

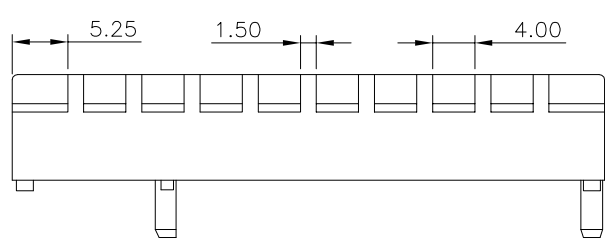
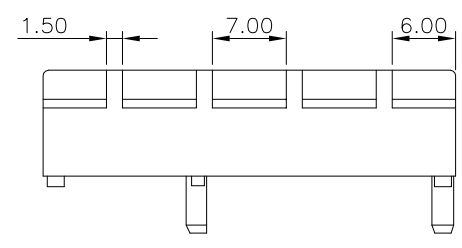

98 POS.

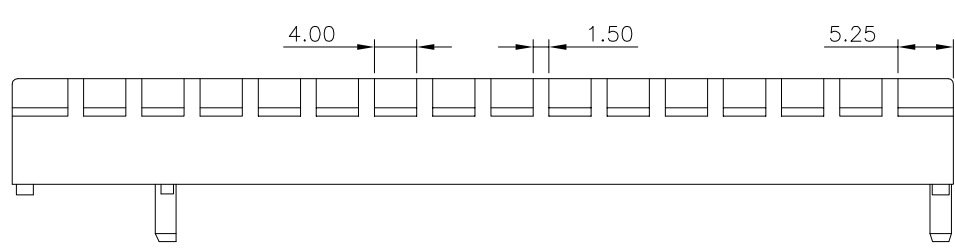
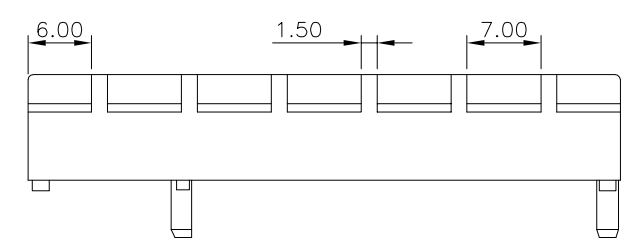

164 POS.

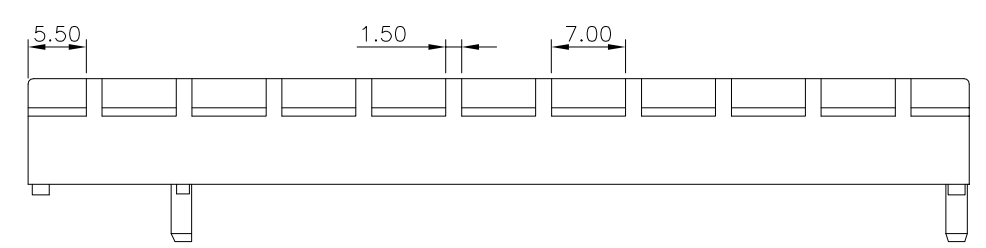

THIS DRAWING IS A CONTROLLED DOCUMENT.		DWN		TE Connectivity	
DIMENSIONS: MM		CHK			
TOLERANCES UNLESS OTHERWISE SPECIFIED:		APVD		NAME	
0 PLC ± - 1 PLC ± 0.25 2 PLC ± 0.25 3 PLC ± 0.25 4 PLC ± - ANGLES ± -		PRODUCT SPEC		PCI EXPRESS CARD EDGE CONNECTOR VERTICAL, DIP TYPE, 3GIO	
MATERIAL		APPLICATION SPEC		SIZE	RESTRICTED TO
FINISH		WEIGHT		A3	
		CUSTOMER DRAWING		CAGE CODE	DRAWING NO
				00779	1734774
		SCALE		SHEET	REV
				3 OF 5	G

THIS DRAWING IS UNPUBLISHED. RELEASED FOR PUBLICATION AUG ,2006.
 © COPYRIGHT BY TYCO ELECTRONICS CORPORATION. ALL RIGHTS RESERVED.

LOC	DIST	REVISIONS			
P	LTR	DESCRIPTION	DATE	DWN	APVD
DW		SEE SHEET 1.			

ADD-IN CARD EDGE-FINGER DIMENSIONS

NOTES:
 CHAMFER EDGE MUST BE FREE OF CUTTING BURRS

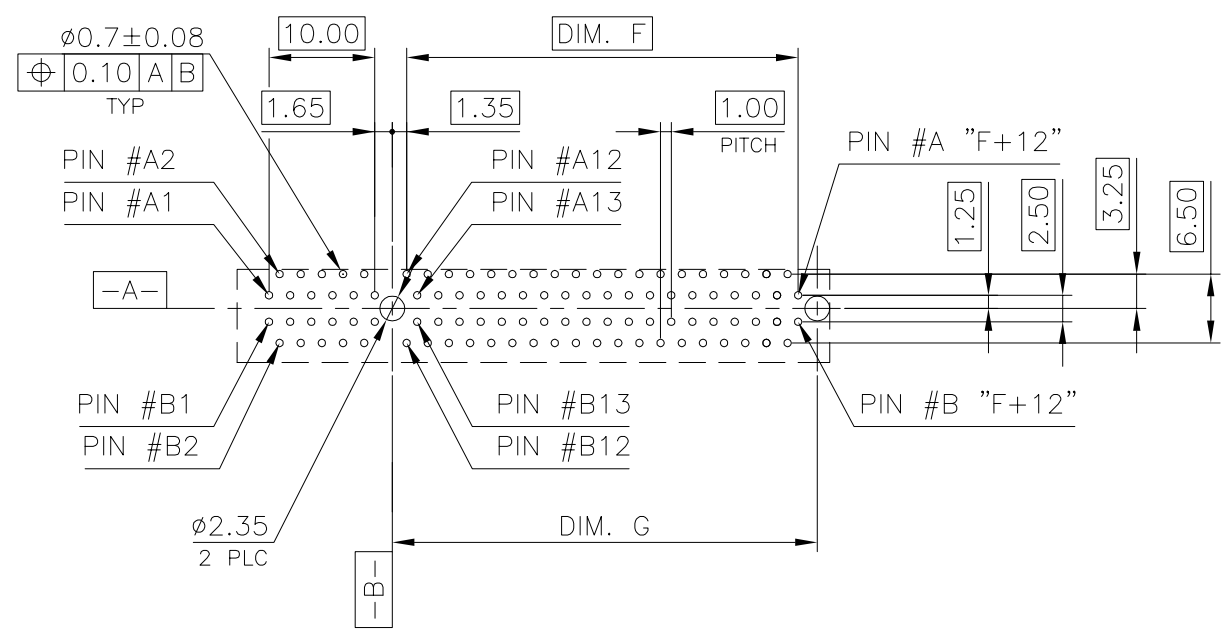

TOLERANCE: ±0.05
 FOR DIM.L=3.1mm PCB THICKNESS: 2.4mm
 FOR DIM.L=2.3mm PCB THICKNESS: 1.6mm

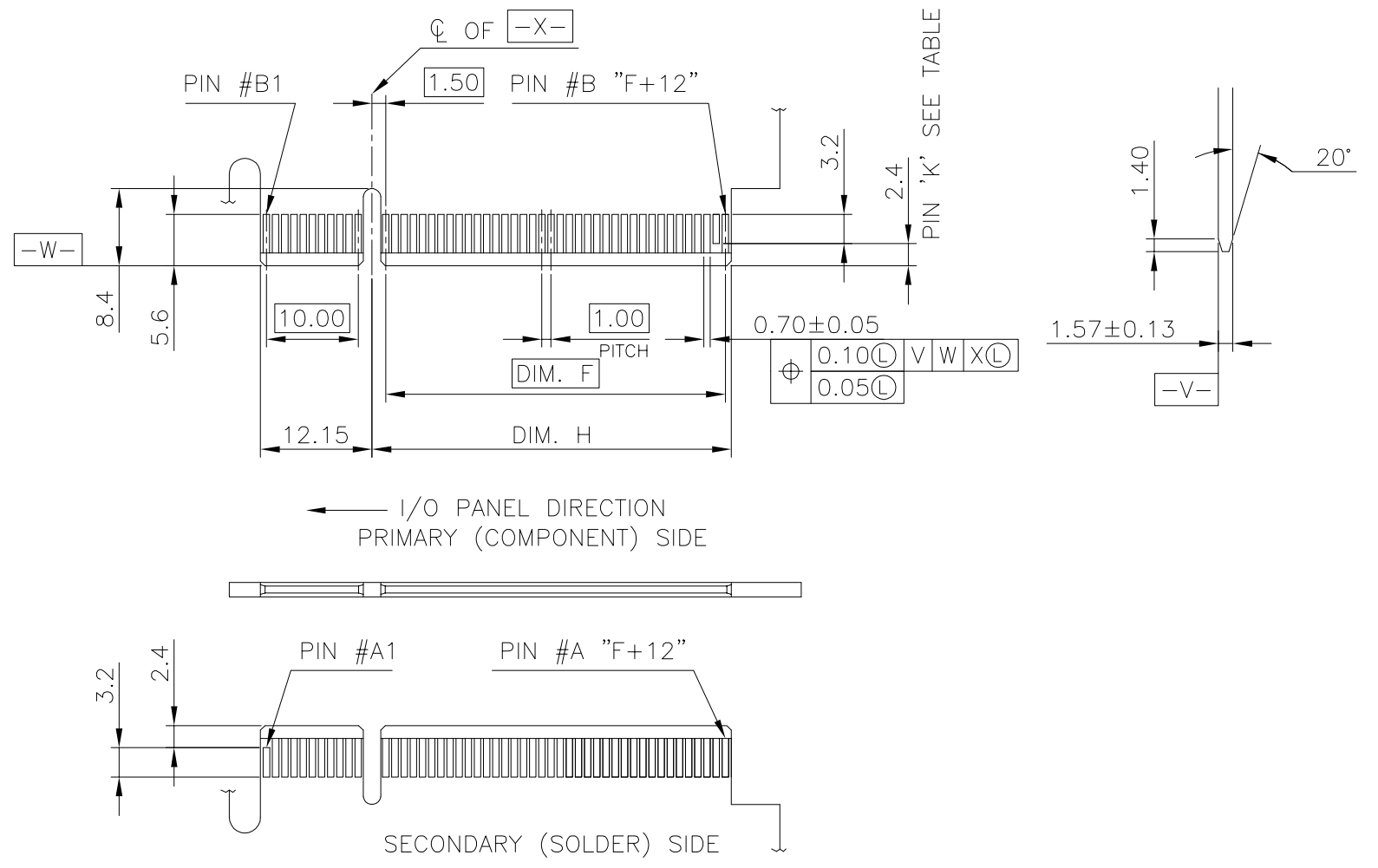

POS.	DIM. F	DIM. G	DIM. H	"K"
164	70.0	73.15	72.15	A1, B17, B31, B48, B81
98	37.0	40.15	39.15	A1, B17, B31, B48
64	20.0	23.15	22.15	A1, B17, B31
36	6.0	9.15	8.15	A1, B17

THIS DRAWING IS A CONTROLLED DOCUMENT.		DWN			
DIMENSIONS: MM		CHK			
TOLERANCES UNLESS OTHERWISE SPECIFIED:		APVD		NAME	
0 PLC ± -		PRODUCT SPEC		PCI EXPRESS CARD EDGE CONNECTOR VERTICAL, DIP TYPE, 3GIO	
1 PLC ± -		APPLICATION SPEC		SIZE CAGE CODE DRAWING NO RESTRICTED TO	
2 PLC ± -		WEIGHT		A3 00779 C=1734774	
3 PLC ± -		CUSTOMER DRAWING		SCALE SHEET 4 OF 5 REV G	
4 PLC ± -					
ANGLES ± -					
FINISH					

THIS DRAWING IS UNPUBLISHED. RELEASED FOR PUBLICATION AUG ,2006.
 © COPYRIGHT BY TYCO ELECTRONICS CORPORATION. ALL RIGHTS RESERVED.

LOC	DIST	REVISIONS					
DW		P	LTR	DESCRIPTION	DATE	DWN	APVD
				SEE SHEET 1.			

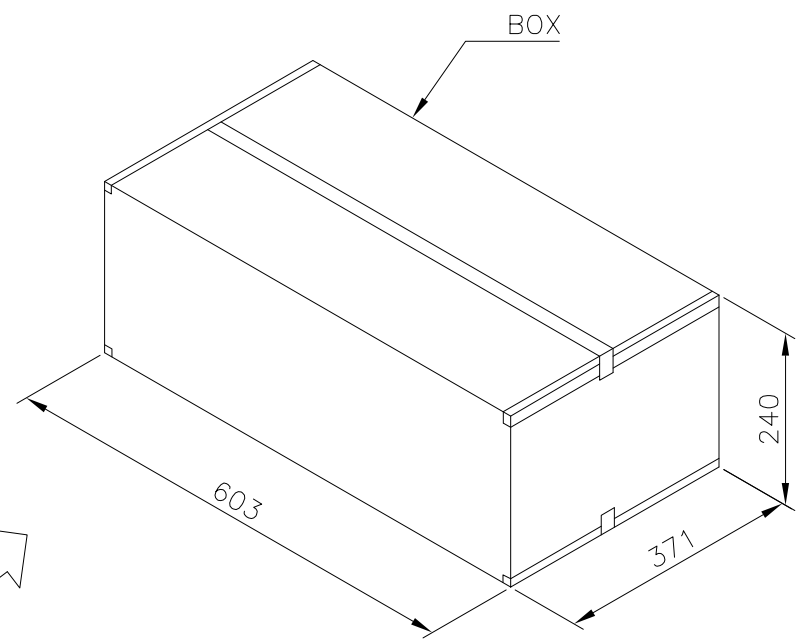
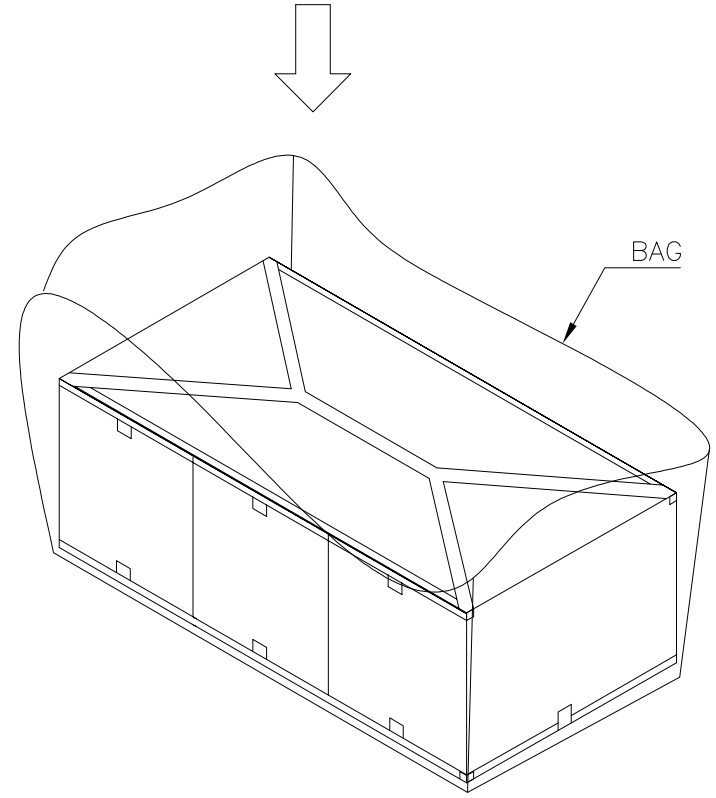
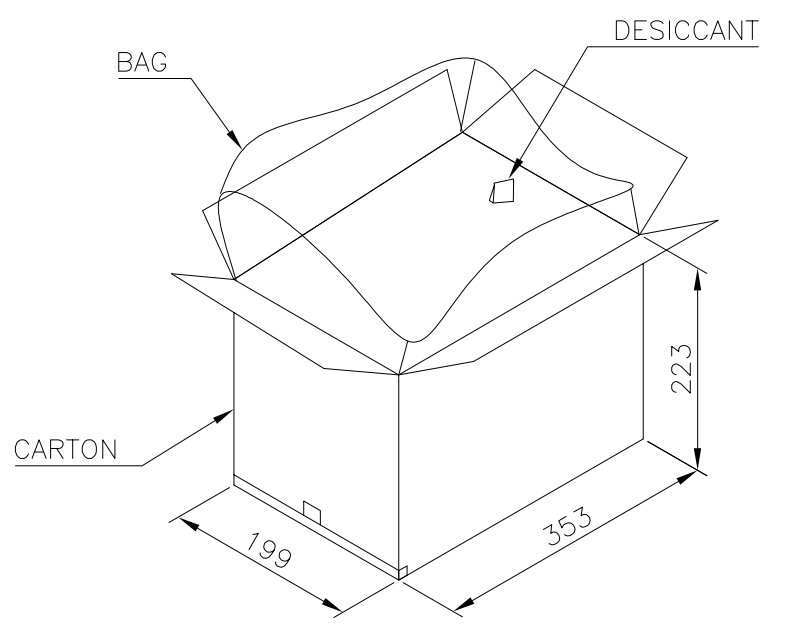
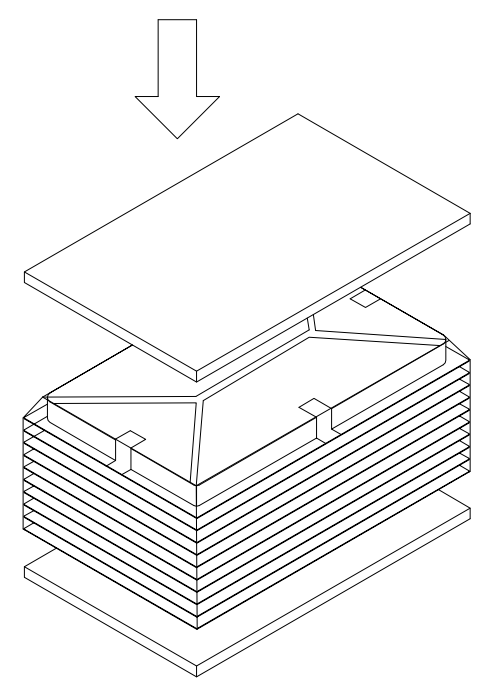
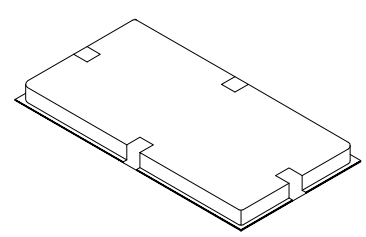
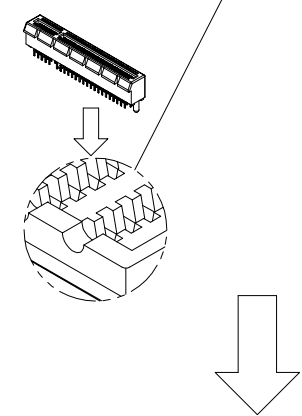
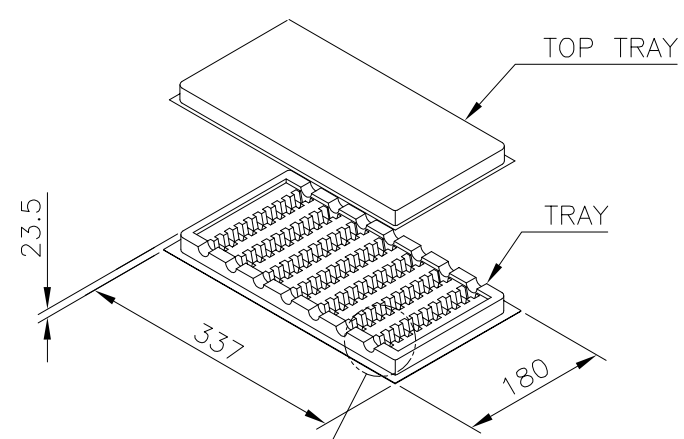

- NOTES :
- MATERIAL :
 TRAY : PVC, COLOR: TRANSPARENT.
 CARTON: CORRUGATED FIBER
 BOX: CORRUGATED FIBER
 - DIMENSION :
 TRAY: SEE DRAWING
 CARTON: SEE DRAWING
 BOX : SEE DRAWING
 - QUANTITY : SEE TABLE
 - WEIGHT : SEE TABLE

10.2 Kg	8.2 Kg	30	10	3	900	164
9.0 Kg	7.0 Kg	40	10	3	1200	98
8.5 Kg	6.5 Kg	60	10	3	1800	64
7.6 Kg	5.6 Kg	70	10	3	2100	36
GROSS WEIGHT	NET WEIGHT	PCS/ TRAY	TRAY/ CARTON	CARTON/ BOX	PCS/ BOX	POS.

THIS DRAWING IS A CONTROLLED DOCUMENT.		DWN	TE Connectivity			
DIMENSIONS: MM		CHK	NAME			
TOLERANCES UNLESS OTHERWISE SPECIFIED: 0 PLC ± - 1 PLC ± - 2 PLC ± - 3 PLC ± - 4 PLC ± - ANGLES ± -		APVD	PCI EXPRESS CARD EDGE CONNECTOR VERTICAL, DIP TYPE, 3GIO			
MATERIAL		PRODUCT SPEC	SIZE	CAGE CODE	DRAWING NO	RESTRICTED TO
FINISH		APPLICATION SPEC	A3	00779	C=1734774	
		WEIGHT	CUSTOMER DRAWING		SCALE	SHEET 5 of 5
						REV G