



Chipsmall Limited consists of a professional team with an average of over 10 year of expertise in the distribution of electronic components. Based in Hongkong, we have already established firm and mutual-benefit business relationships with customers from,Europe,America and south Asia,supplying obsolete and hard-to-find components to meet their specific needs.

With the principle of “Quality Parts,Customers Priority,Honest Operation,and Considerate Service”,our business mainly focus on the distribution of electronic components. Line cards we deal with include Microchip,ALPS,ROHM,Xilinx,Pulse,ON,Everlight and Freescale. Main products comprise IC,Modules,Potentiometer,IC Socket,Relay,Connector.Our parts cover such applications as commercial,industrial, and automotives areas.

We are looking forward to setting up business relationship with you and hope to provide you with the best service and solution. Let us make a better world for our industry!



## Contact us

Tel: +86-755-8981 8866 Fax: +86-755-8427 6832

Email & Skype: info@chipsmall.com Web: www.chipsmall.com

Address: A1208, Overseas Decoration Building, #122 Zhenhua RD., Futian, Shenzhen, China



LOC DW	DIST	REVISIONS			
P	LTR	DESCRIPTION	DATE	DWN	APVD
A		RELEASED	18MAR10	SC	WK

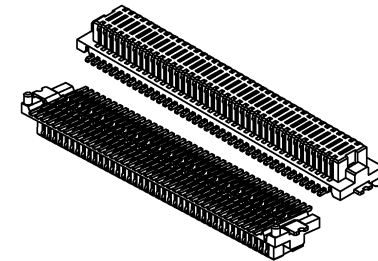
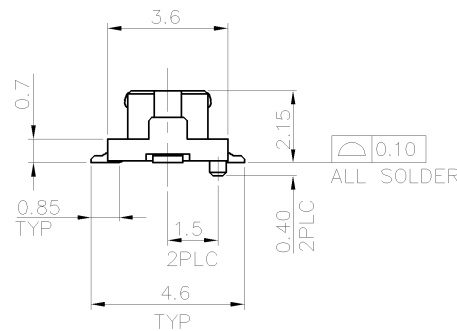
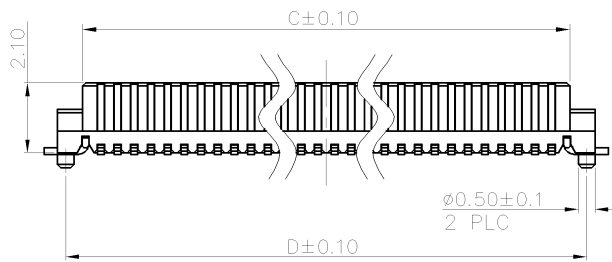
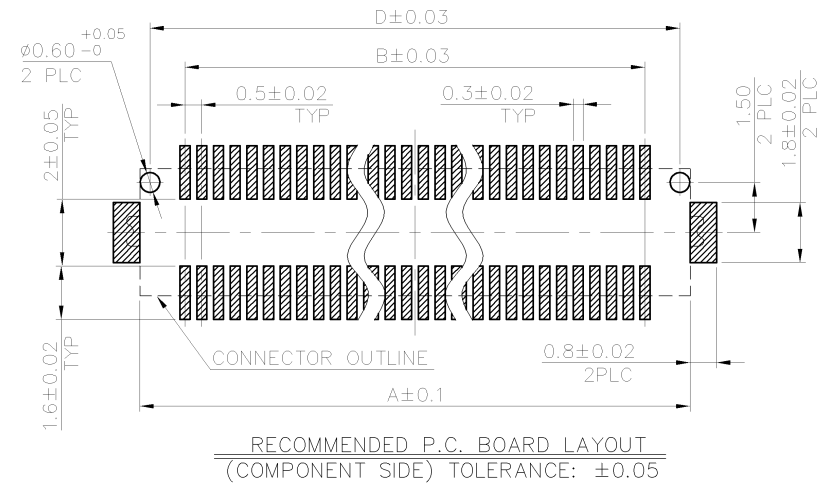
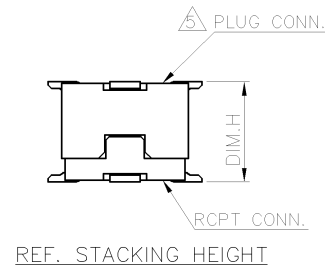
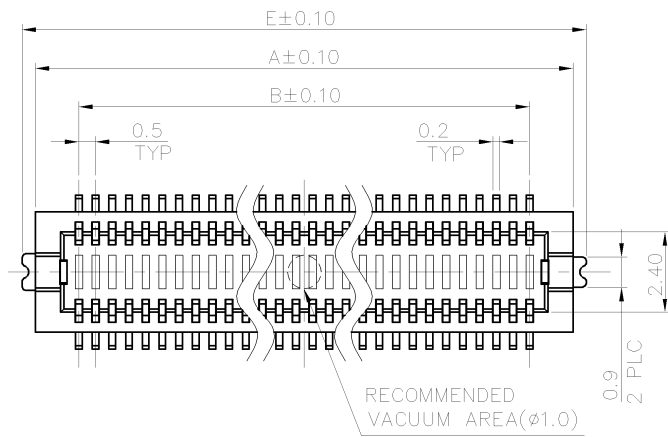

- NOTE:
- MATERIAL:  
 HOUSING: THERMOPLASTIC (LCP) WITH 30% GF, UL 94V-0, BLACK COLOR.  
 CONTACTS: PHOSPHOR BRONZE.  
 PEGS: BRASS.
  - FINISH:  
 CONTACTS: 0.254μm [10μ"] MIN. GOLD PLATED ON CONTACT AREA, GOLD FLASH ON SOLDER TAIL, WITH 1.27μm [50μ"] MIN. NICKEL UNDERPLATING.  
 PEGS: 2.54μm [100μ"] MIN. MATTE-TIN OVER 1.27μm [50μ"] MIN NICKEL.
  - REFLOW SOLDER CAPABLE TO 260°C AS PER TE SPEC. TEC-109-201, CONDITION B.
  - NO TE LOGO AND DATE CODE ON THE PRODUCT.
- △ PLUG PART NUMBERS (BASE NO.#):  
 5.1. DIM.H=3MM: 1775167 THRU 1775185, AND 2041250.  
 5.2. DIM.H=5MM: 1775186
- LOW HALOGEN SPECIFICATION:  
 CHLORINE(Cl): 900ppm MAX.  
 BROMINE(Br): 900ppm MAX.

0.33g	22.90	21.60	20.60	19.50	22.10	80	8-2041251-0
0.10g	7.90	6.60	5.60	4.50	7.10	20	2-2041251-0
WEIGHT	DIMENSIONS					NO. OF CONTACTS	PART NUMBER

THIS DRAWING IS A CONTROLLED DOCUMENT.		DWN S. CHIEN 18MAR2010	Tyco Electronics Corporation Taipei, Taiwan	
DIMENSIONS: MM		CHK S. CHIEN 18MAR2010	NAME W. KODAMA	
TOLERANCES UNLESS OTHERWISE SPECIFIED: 0 PLC ± - 1 PLC ± 0.3 2 PLC ± 0.2 3 PLC ± 0.15 4 PLC ± - ANGLES ± ± 3'		APVD W. KODAMA 18MAR2010	PRODUCT SPEC 108-57578	
MATERIAL SEE NOTE		FINISH SEE NOTE	APPLICATION SPEC -	RESTRICTED TO
		WEIGHT SEE TABLE	SIZE A3	CAGE CODE 00779
		DRAWING NO. C=2041251		SCALE
CUSTOMER DRAWING		SHEET 1 OF 2		REV A

LOC	DIST	REVISIONS					
DW		P	LTR	DESCRIPTION	DATE	DWN	APVD
		SEE SHEET 1.					

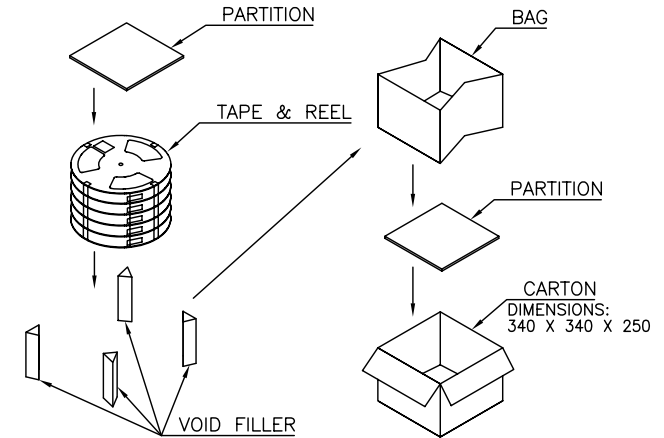
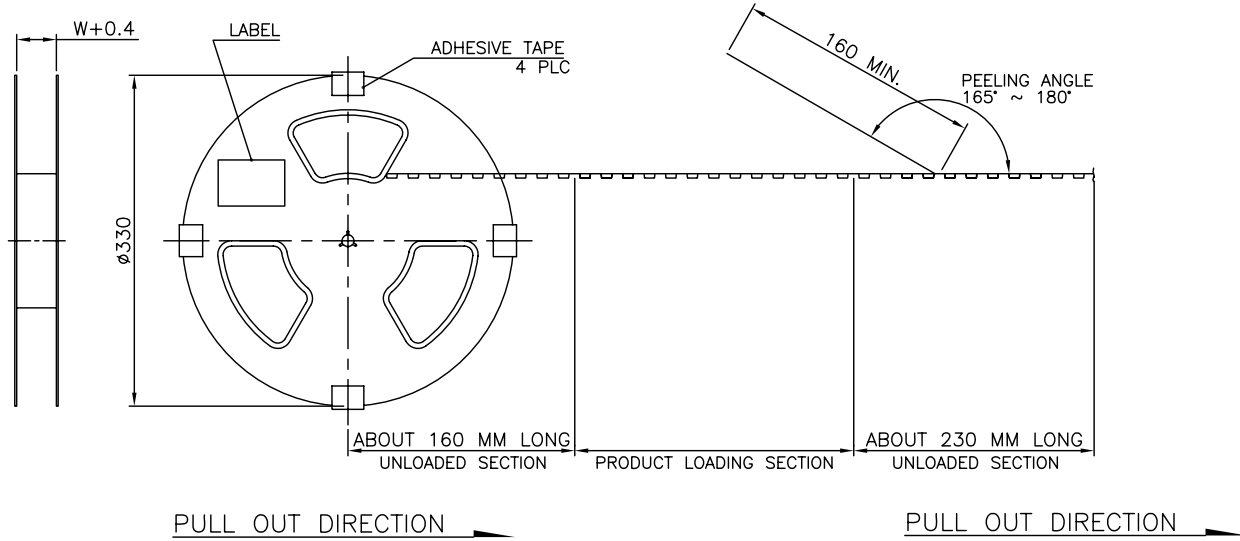

- NOTE:
- PACKAGING MATERIAL IN PLASTIC, RUBBER, INK, PIGMENT AND PAINT MUST MEET CONTROLLED SUBSTANCES BELOW.  
 \* CADMIUM AND CADMIUM COMPOUNDS NOT TO EXCEED: 5 PPM.  
 \* LEAD, CADMIUM, CHROM VI AND MERCURY NOT TO EXCEED :100 PPM (COMBINED).
  - EACH BAG SHALL BE INCLUDED:  
 \* DESICCANT
  - CARRIER TAPES, COVER TAPES, REELS AND TAPED COMPONENTS MUST MEET THE REQUIREMENTS DEFINED PER EIA-481-B.
  - CARRIER TAPES & COVER TAPES MATERIAL: P.S.
  - PEELING FORCE: 10g ~ 130g.

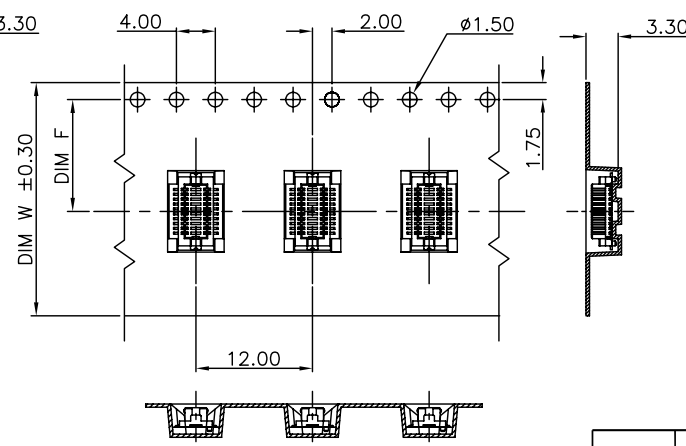
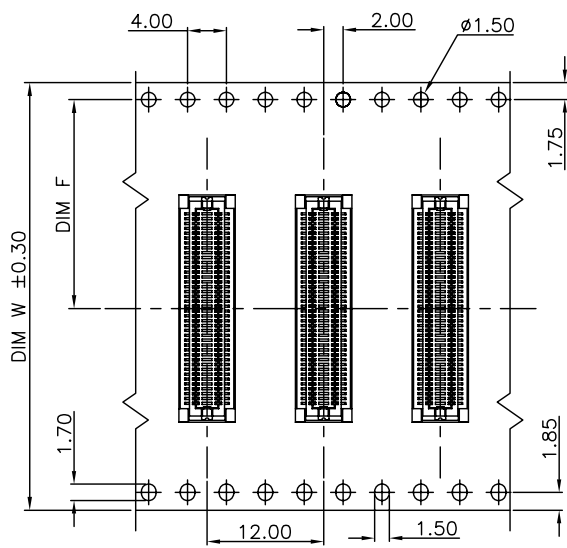

CARRIER FOR 20 POSITION

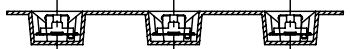

CARRIER FOR 80 POSITION

1000	4	4000	20.2	44	4.58	1.32	8-2041251-0
	10	10000	7.5	16	6.89	0.99	2-2041251-0
PCS/REEL	REELS/BOX	QUANTITY	DIM F	DIM W	G/W (KG)	N/W (KG)	PART NUMBER

THIS DRAWING IS A CONTROLLED DOCUMENT.

DIMENSIONS: MM	TOLERANCES UNLESS OTHERWISE SPECIFIED:	DWN	Tyco Electronics Corporation Taipei, Taiwan			
0 PLC ± -	1 PLC ± -	CHK	<b>Tyco Electronics</b> BOARD TO BOARD CONNECTOR, 0.5mm PITCH, FINE-MATE, RECEPTACLE, WITH BOSSES & PEG			
2 PLC ± -	3 PLC ± -	APVD				
4 PLC ± -	ANGLES ± -	PRODUCT SPEC				
MATERIAL	FINISH	APPLICATION SPEC				
		WEIGHT	SIZE	CAGE CODE	DRAWING NO	RESTRICTED TO
		SEE TABLE	A3	00779	G=2041251	
CUSTOMER DRAWING			SCALE	SHEET	REV	
				2 OF 2	A	