



Chipsmall Limited consists of a professional team with an average of over 10 year of expertise in the distribution of electronic components. Based in Hongkong, we have already established firm and mutual-benefit business relationships with customers from,Europe,America and south Asia,supplying obsolete and hard-to-find components to meet their specific needs.

With the principle of “Quality Parts,Customers Priority,Honest Operation,and Considerate Service”,our business mainly focus on the distribution of electronic components. Line cards we deal with include Microchip,ALPS,ROHM,Xilinx,Pulse,ON,Everlight and Freescale. Main products comprise IC,Modules,Potentiometer,IC Socket,Relay,Connector.Our parts cover such applications as commercial,industrial, and automotives areas.

We are looking forward to setting up business relationship with you and hope to provide you with the best service and solution. Let us make a better world for our industry!



Contact us

Tel: +86-755-8981 8866 Fax: +86-755-8427 6832

Email & Skype: info@chipsmall.com Web: www.chipsmall.com

Address: A1208, Overseas Decoration Building, #122 Zhenhua RD., Futian, Shenzhen, China



THIS DRAWING IS UNPUBLISHED. RELEASED FOR PUBLICATION
 © COPYRIGHT - By - ALL RIGHTS RESERVED.

LOC	DIST	REVISIONS					
		P	LTR	DESCRIPTION	DATE	DWN	APVD
G	14		L2	REVISED PER ECO-12-007718	07MAY12	KH	DR

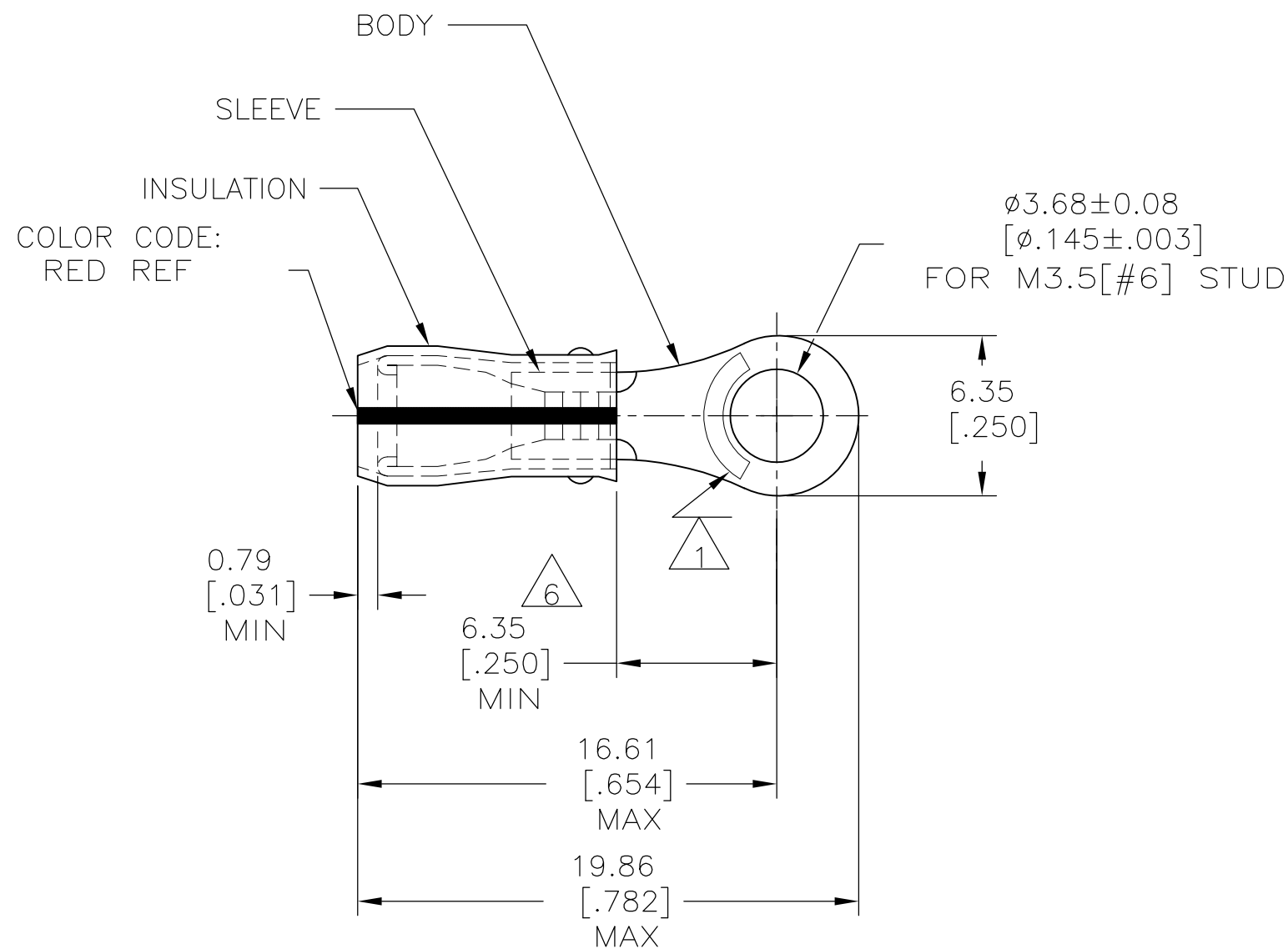

- 1 STAMP AMP 22-18* APPROX AS SHOWN
22-16 TERMINALS ARE STAMPED 22-18 IN ACCORDANCE WITH MILITARY SPEC SAE AS7928
COMMERCIAL WIRE RANGE IS 22-16.
- 2 WIRE INSULATION DIA: 2.03-3.18 [.080 - .125]
- 3 TONGUE MATERIAL THK: 0.79±0.05 [.031±.002]
- 4 BODY & SLEEVE: TIN/LEAD (93-7) PLATE PER ASTM B545, (3% MIN LEAD CONTENT)
- 5 BODY & SLEEVE- CU PER ASTM B152
INSULATION - PVF2, COLOR - NATURAL
- 6 DIMENSION APPLIES FROM EDGE OF METAL WIRE BARREL TO CENTER OF STUD HOLE.

MILITARY P/N & CLASS	QTY	PACKAGE TYPE	PART NO.
-	100	LOOSE PIECE, BOX	8-53407-1
M7928/4-102, CLASS 2	5000	ON TAPE, REEL	53407-2
M7928/4-102, CLASS 1 & 2 M7928/13-102, CLASS 1 & 2	1000	LOOSE PIECE	53407-1

AMP INCORPORATED CUSTOMER SERVICE SYSTEMS		MAX RECOMMENDED OPERATING TEMPERATURE: 150°C[302°F] MAX	THIS DRAWING IS A CONTROLLED DOCUMENT.		DWN DK SCHRUM 06/16/93	TE Connectivity NAME TERMINAL, RING TONGUE, PVF2, P.I.D.G. WIRE SIZE: 22-16 AWG				
FOR ADDITIONAL PRODUCT INFORMATION OR COPIES OF DRAWINGS AND TECHNICAL DOCUMENTS	PRODUCT INFORMATION CENTER 1-800-522-6752	VOLTAGE RATING: N/A	DIMENSIONS: mm [INCHES]	TOLERANCES UNLESS OTHERWISE SPECIFIED:	CHK RE HERSEY 7/6/93				APVD M ELLIS 7/6/93	SIZE
FOR APPLICATION TOOLING INFORMATION	TOOLING ASSISTANCE CENTER 1-800-722-1111	CIRCULAR MIL AREA: 0.26-1.65mm²[509-3260] STRANDED		0 PLC ± - 1 PLC ± - 2 PLC ± 0.20[.008] 3 PLC ± - 4 PLC ± - ANGLES ± -	PRODUCT SPEC -	APPLICATION SPEC NOT AVAILABLE	A3	00779	G-53407	-
FOR ORDER ENTRY	1-800-526-5142	THIS DRAWING IS A CONTROLLED DOCUMENT FOR AMP INCORPORATED. IT IS SUBJECT TO CHANGE AND THE CONTROLLING ENGINEERING ORGANIZATION SHOULD BE CONTACTED FOR THE LATEST REVISION.	MATERIAL	FINISH	WEIGHT -	CUSTOMER DRAWING	SCALE 4:1	SHEET 1 OF 1	REV L2	