



Chipsmall Limited consists of a professional team with an average of over 10 year of expertise in the distribution of electronic components. Based in Hongkong, we have already established firm and mutual-benefit business relationships with customers from,Europe,America and south Asia,supplying obsolete and hard-to-find components to meet their specific needs.

With the principle of “Quality Parts,Customers Priority,Honest Operation,and Considerate Service”,our business mainly focus on the distribution of electronic components. Line cards we deal with include Microchip,ALPS,ROHM,Xilinx,Pulse,ON,Everlight and Freescale. Main products comprise IC,Modules,Potentiometer,IC Socket,Relay,Connector.Our parts cover such applications as commercial,industrial, and automotives areas.

We are looking forward to setting up business relationship with you and hope to provide you with the best service and solution. Let us make a better world for our industry!



Contact us

Tel: +86-755-8981 8866 Fax: +86-755-8427 6832

Email & Skype: info@chipsmall.com Web: www.chipsmall.com

Address: A1208, Overseas Decoration Building, #122 Zhenhua RD., Futian, Shenzhen, China



LOC	DIST	ZONE	LTR	REVISIONS	DATE	APPD
G	14		B	REV, RDRW, & SM PKG PER 0720-0040-93	3-26-93	JL MECKLEY

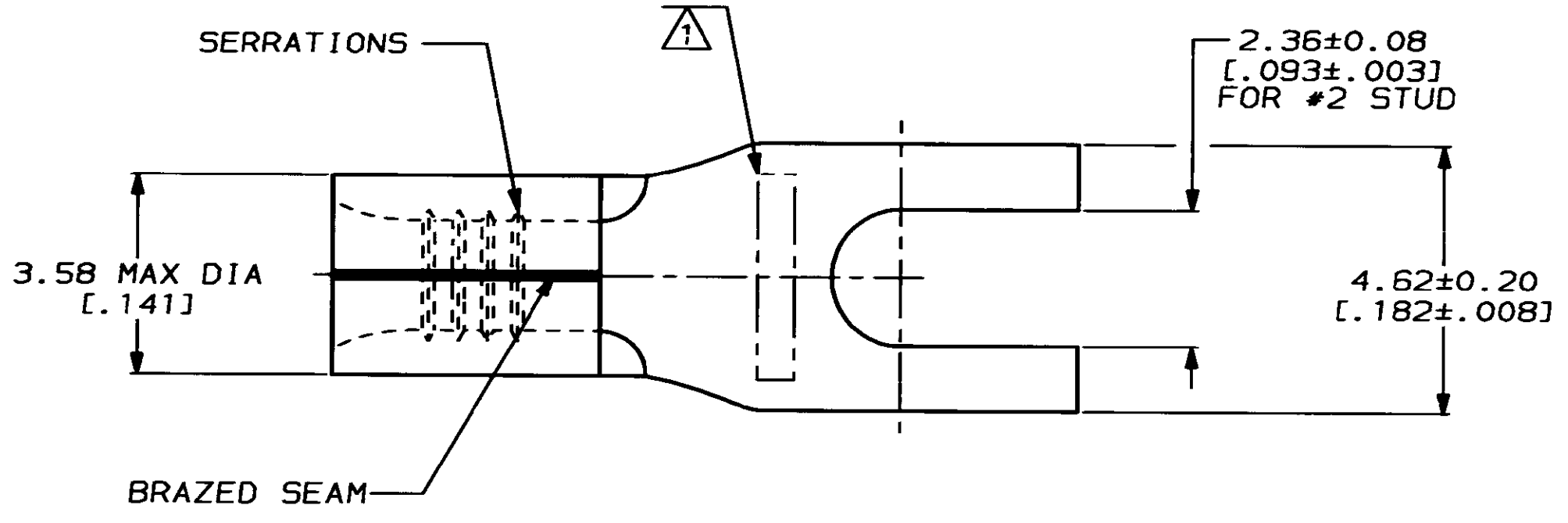

AMP WIRE RANGE	E13288 Listed
22-16 AWG SOLID OR STRANDED	22-16 AWG SOLID OR STRANDED
LR7189 Certified	MILITARY P/N AND CLASS
22-16 AWG SOLID OR STRANDED	NOT APPLICABLE

1 STAMP AMP 22-18* APPROX AS SHOWN
 22-16 TERMINALS ARE STAMPED 22-18 IN
 ACCORDANCE WITH MILITARY SPECIFICATION
 MIL-T-7928, COMMERCIAL WIRE RANGE IS 22-16

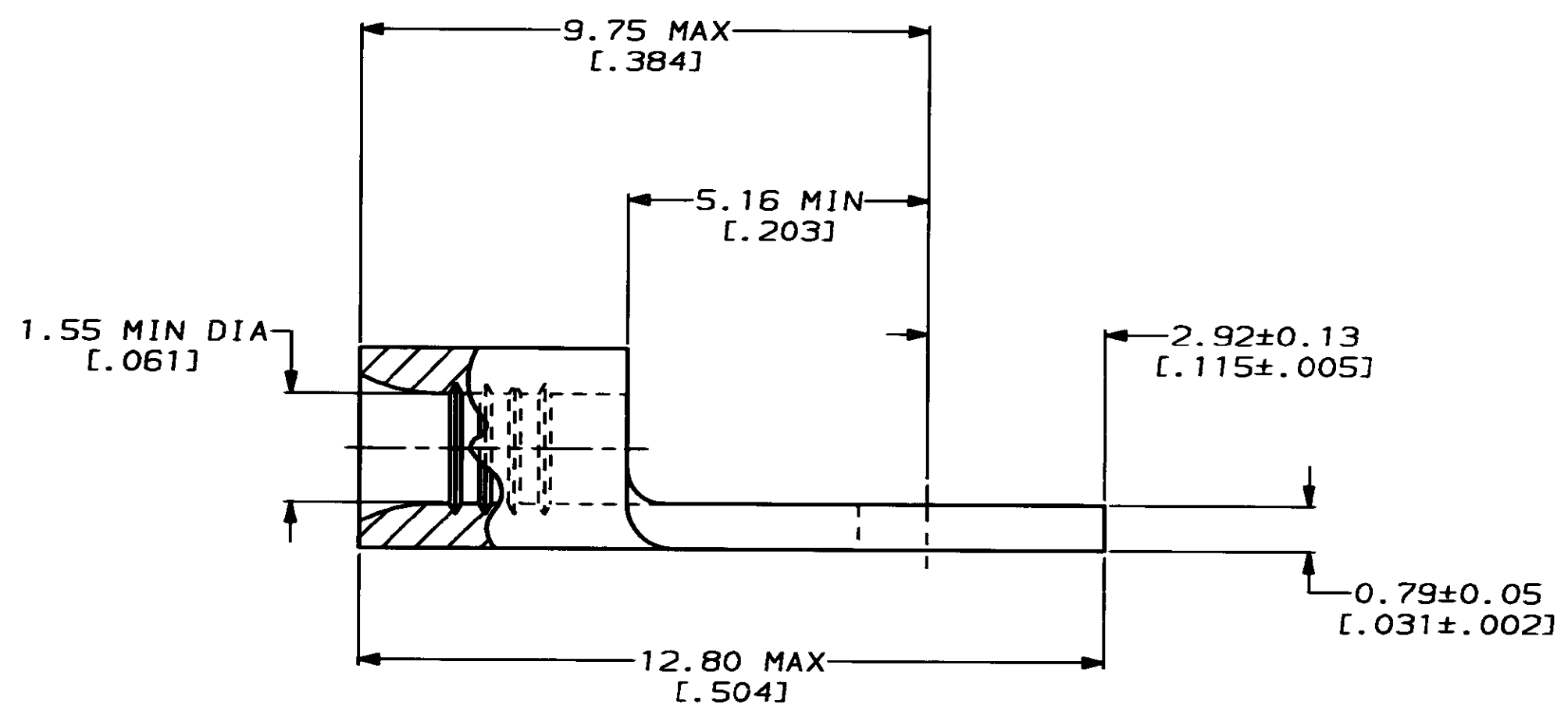

QUANTITY	PACKAGING TYPE	PART NO
100	LOOSE PIECE, BOX	8-53555-1
5000	ON TAPE	53555-2
---	LOOSE PIECE	53555-1

AMP INCORPORATED CUSTOMER SERVICE SYSTEMS		MAX RECOMMENDED OPERATING TEMPERATURE: 170°C MAX	DO NOT SCALE PRINT. UNLESS SPECIFIED DIMENSIONS IN mm [INCHES] TOLERANCES ON: 2 PLC DEC ± - 3 PLC DEC ± - ANGLES ± -	DR 3-26-93 TA BRINKMAN CHK 3-26-93 DA PATTERSON APPD 3-26-93 DE MILLER APPD 3-26-93 JL MECKLEY PRODUCT SPEC APPLICATION SPEC WEIGHT -	AMP AMP Incorporated Harrisburg, PA 17105-3608
FOR ADDITIONAL PRODUCT INFORMATION OR COPIES OF DRAWINGS AND TECHNICAL DOCUMENTS	PRODUCT INFORMATION CENTER 1-800-522-6752	VOLTAGE RATING: NOT APPLICABLE	MATERIAL COPPER PER ASTM B-152 ANNEALED	NAME TERMINAL, SPADE TONGUE, SOLISTRAND™	SIZE CAGE CODE DRAWING NO C 00779 C-53555 SCALE 10:1 SHEET 1 OF 1
FOR APPLICATION TOOLING INFORMATION	TOOLING ASSISTANCE CENTER 1-800-722-1111	WIRE CROSS SECTIONAL AREA RANGE: 0.26-1.65mm ² [509-3,260] CIR MILS SOLID OR STRANDED	FINISH TIN PLATE 0.00254 [.000100] MIN THK PER MIL-T-10727		
FOR ORDER ENTRY	1-800-526-5142	THIS DRAWING IS A CONTROLLED DOCUMENT FOR AMP INCORPORATED. IT IS SUBJECT TO CHANGE AND THE CONTROLLING ENGINEERING ORGANIZATION SHOULD BE CONTACTED FOR THE LATEST REVISION.			