



Chipsmall Limited consists of a professional team with an average of over 10 year of expertise in the distribution of electronic components. Based in Hongkong, we have already established firm and mutual-benefit business relationships with customers from,Europe,America and south Asia,supplying obsolete and hard-to-find components to meet their specific needs.

With the principle of “Quality Parts,Customers Priority,Honest Operation,and Considerate Service”,our business mainly focus on the distribution of electronic components. Line cards we deal with include Microchip,ALPS,ROHM,Xilinx,Pulse,ON,Everlight and Freescale. Main products comprise IC,Modules,Potentiometer,IC Socket,Relay,Connector.Our parts cover such applications as commercial,industrial, and automotives areas.

We are looking forward to setting up business relationship with you and hope to provide you with the best service and solution. Let us make a better world for our industry!



Contact us

Tel: +86-755-8981 8866 Fax: +86-755-8427 6832

Email & Skype: info@chipsmall.com Web: www.chipsmall.com

Address: A1208, Overseas Decoration Building, #122 Zhenhua RD., Futian, Shenzhen, China



800/801/802/803 Series Panel Mount Enclosed Fuse Holders

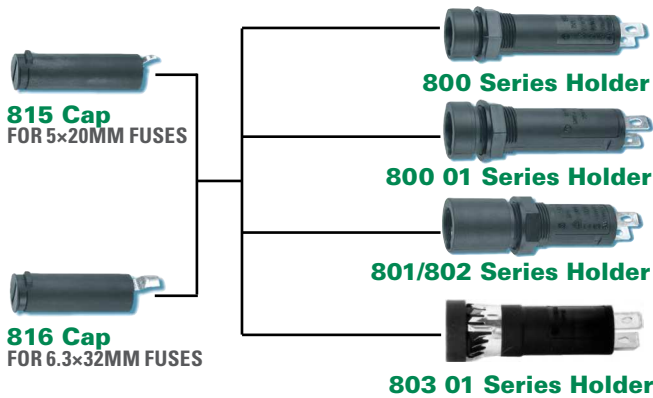

Agency Approval					
Agency	Agency File Number				Agency Approvals
	122016	123336	120629	6914	121076 (802 only)
	E70164	E70164	E70164	E70164	
	47574	47574	47574	47574	

Additional Information



Datasheet
800 Series



Resources
800 Series



Samples
800 Series



Datasheet
801 Series



Resources
801 Series



Samples
801 Series



Datasheet
802 Series



Resources
802 Series



Samples
802 Series



Datasheet
803 Series



Resources
803 Series



Samples
803 Series

Product Characteristics

Series:	800	800 01	801/802	803 01
Compatible Fuses	5x20mm 6.3x32mm	6.3x32mm	5x20mm 6.3x32mm	6.3x32mm
Materials	Holder/Cap: Black Thermoplastic, UL94 V-0			
	Clamp spring: non-corrosion metal, untreated			
	Metal Parts: Copper alloy, corrosion protected			
Electrical Data (23°C)	Terminals: Solderable, tinned			
	Rated Voltage: 250V	Rated Voltage: 250V	Rated Voltage: 250V	Rated Voltage: 500V
	Rated Current: 6.3A (800+815 - VDE) 10A (800+816 - VDE) 16A (UL/CSA)	Rated Current: 10A (800+816 - VDE) 16A (UL/CSA)	Rated Current: 6.3 A (VDE) with cap 815 10 A (VDE) with cap 816	Rated Current: 10 A (VDE) 16 A (UL CSA)
	Rated Power: 2.5W (VDE)			Rated Power: 4W (VDE)
	Mounting			12.7mm diameter D-hole or double D-hole Admissible torque on plastic hex nut is 1.2Nm Pluggable with clamping spring in 12.7mm diameter D-hole (panel of 0.75mm - 3 mm)
Terminals	Solderable or 4.8mm quick connect-fits 0.5mm tab			
Protection Category	IP 40 (IEC 60529) PC2 (IEC 60127-6)			
Operating Temperature	-25°C to +70°C			
Climatic Test	-25°C/+70°C/21 days (IEC 60068-2-1...3)			
Stock Conditions	+10°C to +60°C relative humidity ≤ 75% yearly average, without dew, maximum value for 30 days - 95%			
Vibration Resistance	24 cycles at 15 min. each (IEC 60068-2-6) 10 - 60Hz at 0.75mm amplitude 60 - 2000Hz at 10g acceleration			NA
Contact Resistance	≤ 5mΩ			
Dielectric Strength	> 1.5 kV			
Impulse Voltage	4 kV, 50 Hz, 1 min., dry			
Insulation Resistance	> 10 ⁹ MΩ (500 VDC, 1 min.)			
Solderability	235°C, 3 sec. (Wave)	235°C, 2 sec. (Wave)	235°C, 2 sec. (Wave)	
	350°C, 1 sec. (Soldering Iron)	350°C, 1 sec. (Soldering Iron)	350°C, 3 sec. (Soldering Iron)	
Solder Heat Resistance	260°C, 5 sec. (IEC 60068-2-20)			
Min. Cross Section	Conductor - 2.5mm ²			
Marking	800, 250V, Approvals	800 01, 250V, Approvals	Series, 250V, Approvals	803, 500V, Approvals
Unit Weight	4.7g (Holder) 2.5g (Cap)		5.0g (801/802) 2.5g (815/816)	4.9g (803) 2.0g (816)

Ordering Information

Holders	800 0000 0005	800 0000 0105	801 0000 0005 802 0000 0005	803 0000 0105
Caps	For 5x20mm fuse: 815 0000 0005 For 6.3x32mm fuse: 816 0000 0005			
Packaging	Bulk 100 Pcs all items listed above			

Dimensions (millimeters)

800 Series

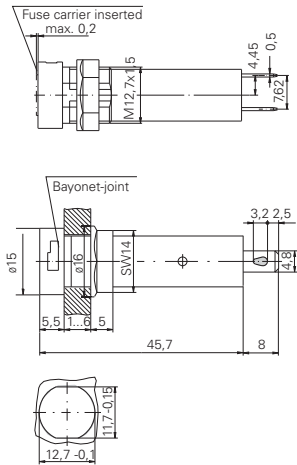

801/802 Series

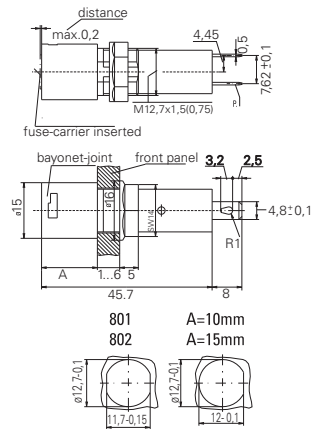

803 01 Series

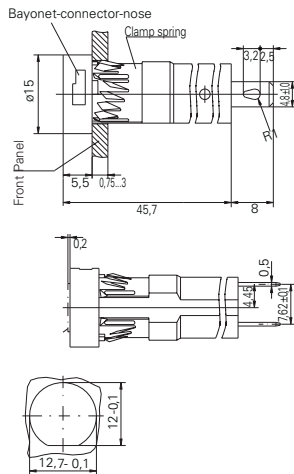

815/816 Cap

