



Chipsmall Limited consists of a professional team with an average of over 10 year of expertise in the distribution of electronic components. Based in Hongkong, we have already established firm and mutual-benefit business relationships with customers from,Europe,America and south Asia,supplying obsolete and hard-to-find components to meet their specific needs.

With the principle of "Quality Parts,Customers Priority,Honest Operation,and Considerate Service",our business mainly focus on the distribution of electronic components. Line cards we deal with include Microchip,ALPS,ROHM,Xilinx,Pulse,ON,Everlight and Freescale. Main products comprise IC,Modules,Potentiometer,IC Socket,Relay,Connector.Our parts cover such applications as commercial,industrial, and automotives areas.

We are looking forward to setting up business relationship with you and hope to provide you with the best service and solution. Let us make a better world for our industry!



## Contact us

Tel: +86-755-8981 8866 Fax: +86-755-8427 6832

Email & Skype: info@chipsmall.com Web: www.chipsmall.com

Address: A1208, Overseas Decoration Building, #122 Zhenhua RD., Futian, Shenzhen, China



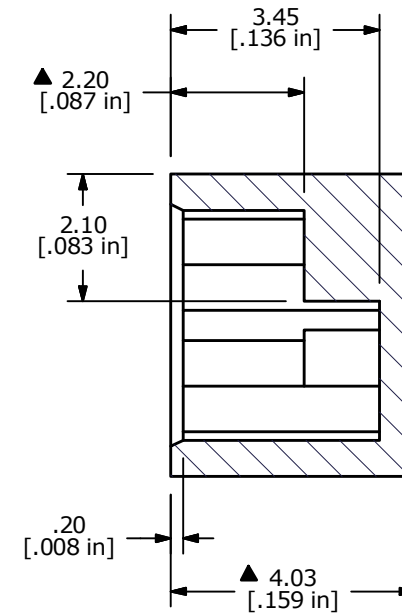
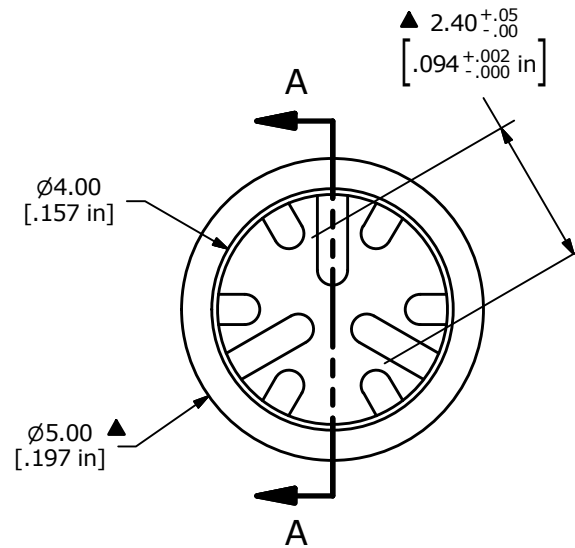
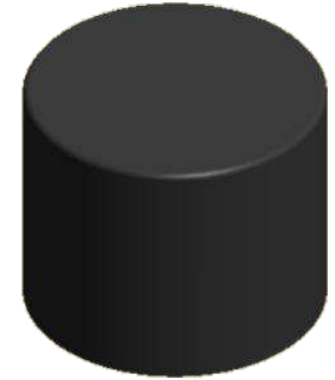

SECTION A-A

NOTES

1. ALL DIMENSIONS IN MM[INCH]
2. GENERAL TOLERANCE: X.X =  $\pm 0.4$   
X.XX =  $\pm 0.25$
- ▲ 3. COLOR: BLACK
4. ▲ DENOTES CRITICAL PARAMETER.
5. 2002/95/EC (ROHS) COMPLIANT

J	22485	REMOVED MATERIAL NOTE	9/6/16	MW
H	16117	ADD MATERIAL AND ROHS NOTE	6/7/06	CT
G	14598	REMOVE TOLERANCE	1/4/05	AR
F	14558	REVISED AND REDRAWN	12/3/04	AR
REV	PCR NO	DESCRIPTION	DATE	BY



TITLE 800C1BLKCAP

THE INFORMATION CONTAINED IN THIS DOCUMENT IS PROPRIETARY TO E-SWITCH AND IS NOT TO BE COPIED OR TRANSFERRED

SCALE	DATE	DR	DWG	REV
8:1	12/3/2004	AR	T800100	J