



Chipsmall Limited consists of a professional team with an average of over 10 year of expertise in the distribution of electronic components. Based in Hongkong, we have already established firm and mutual-benefit business relationships with customers from,Europe,America and south Asia,supplying obsolete and hard-to-find components to meet their specific needs.

With the principle of “Quality Parts,Customers Priority,Honest Operation,and Considerate Service”,our business mainly focus on the distribution of electronic components. Line cards we deal with include Microchip,ALPS,ROHM,Xilinx,Pulse,ON,Everlight and Freescale. Main products comprise IC,Modules,Potentiometer,IC Socket,Relay,Connector.Our parts cover such applications as commercial,industrial, and automotives areas.

We are looking forward to setting up business relationship with you and hope to provide you with the best service and solution. Let us make a better world for our industry!



Contact us

Tel: +86-755-8981 8866 Fax: +86-755-8427 6832

Email & Skype: info@chipsmall.com Web: www.chipsmall.com

Address: A1208, Overseas Decoration Building, #122 Zhenhua RD., Futian, Shenzhen, China



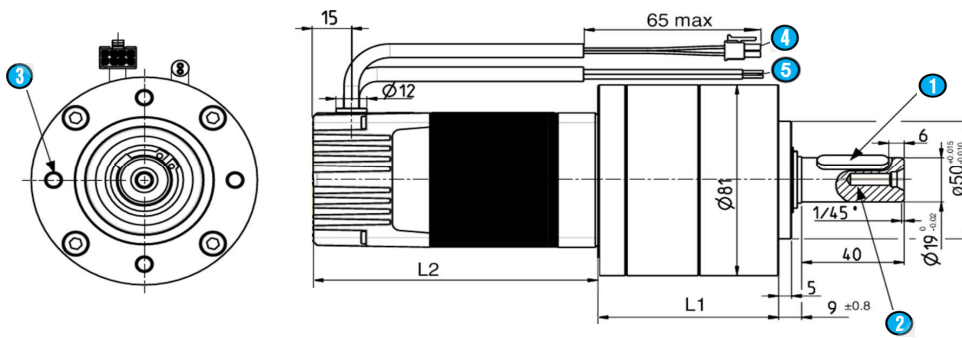

- 1 Key way 6 x 6 x 28 DIN6885A
- 2 M6 x 16
- 3 4 x M6 on 65mm diam - 12 depth

- 4 Input - Output cable - 500 mm ± 20
- 5 Power supply cable - 500 mm ± 20

L1 = 70,5 ± 0,6
L2 = 112 max.

General characteristics

Power supply		
Direct current voltage supply		✓
Nominal voltage range (5)	Vdc	12 -> 48
Max. current	A	15

Gearmotor type		80 289 7 TNI21		
Motor type		80 280 007		
Gearbox type		81 041 0		
Ratio		5,18		
Number of stages		1		
Max. permissible continuous torque	Nm	20		
Max. backlash	°	0,5		

Motor characteristics (1)		12 Vdc	24 Vdc	32 Vdc	
At no load					
Max. output speed	rpm	386	763	763	
Current at the max output speed (6)	A	0,5	0,7	0,6	
Standby current	A	0,08	0,09	0,09	+10%
At nominal					
Speed	rpm	270	627	753	+15%
Torque (2)	Nm	2,3	1,8	1,7	
Output power	W	65	119	130	
Current	A	8,5	6,9	5,5	
Efficiency	%	63	72	74	
At max. output power					
Speed	rpm	154	367	463	+15%
Torque	Nm	4,7	4,7	4,7	
Output power	W	75	179	226	
Current	A	15,3	14,6	12,5	
Efficiency	%	41	51	57	
At peak torque					
Speed	rpm	154	367	463	+15%
Torque	Nm	4,7	4,7	4,7	
Output power	W	75	179	226	
Current	A	15,3	14,6	12,5	
Others					
Weight	kg	3,24			
Noise level	dBA	55			

Connecting	
Input - Output cable	With Molex connector ref: 43025-0800
Output cable, UL style 2464 80°C 300V	- 8 wires AWG24
Input: ON/OFF	1 - Green
Input: Direction	2 - Yellow
Input: Torque limit	3 - Blue
Input: Speed	4 - Orange
0V	5 - Black
Output: Pulse	6 - Brown
Output: Torque limit reached	7 - Purple
Output: Direction	8 - Red
Power supply cable	
Cable UL style 2517 105°C 300V	- 2 wires AWG16 - 500 mm
+ 12Vcc -> + 48 Vdc (5)	Brown
0V	Blue

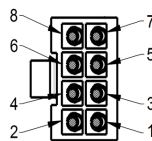

Drive	
Type	TNI21
Built-in drive	✓
Internal encoder	24 pulses per turn
Control	
Speed	0/10 V
Torque	0/10 V
4 quadrants - low braking	✓
4 quadrants with regenerative energy	
"Trapezoidal" type	✓
Security	
Short-circuit of outputs	✓
Input inverted	✓
Low voltage	Vdc < 9
Short high voltage	Vdc > 56
Stop at max internal drive temperature (2)	°C 110
Drive temperature allowing to restart	°C 90

Generic parameters			
Output shaft with ball bearings		✓	
Max. Radial force (12mm from front face)	N		400
Max. axial force(4)	N		80
Temperature range	CEI60068-2-1/2	°C	-30 -> +70
Storage temperature		°C	-40 -> +80
Dielectric	1min 2mA 50Hz	CEI60335	Vac 1 000
Motor insulation	CEI60085	class	E
Salt spray	CEI60068-2-58	severity	48h
Degree of protection (output shaft not included)	CEI60529	IP	65
EMC			
Electrostatic Discharge	CEI61000-4-2	level	3
Electrical fast transient / burst test	CEI61000-4-4	level	3
Surge test	CEI61000-4-5	level	1
Radiated emission	EN55022	class	B
Approvals			
ROHS	2011/65/UE	✓	
EC	2014/30/UE	✓	

Notes	
Values without tolerance are average production values.	
Added informations are in "TNI21 manual and security". Available on www.crouzet-motors.com .	
Motor not protected in case of reversed power voltage	
(1) Cold motor, 20 °C ambient temperature, full speed	
(2) Max torque for continuous operation at 20 °C, decrease this value for higher ambient temperature	
(4) Pinion or pulley fitting are done at the Crouzet factory, before final assembly.	
(5) Before September 2015: Nominal was 12 -> +32Vdc, Short high voltage was > 36Vdc, Absolute max. was 39Vdc	
(6) Value without gearbox. With gearbox, the value increases and varies depending on grease temperature.	

Drive electrical datas

Absolute maximum ratings			
Parameters			
Max. voltage supply "Vcc" (5)	Vdc		85
Max. current "Icc max"	A		20
Max. voltage on inputs "Vin max" (5)	Vdc		50
Max. voltage on outputs "Vout max" (5)	Vdc		85
Max. output current "Iout max"	mA		50
Running datas			
Parameters			
Voltage supply "Vcc" (5)	Vdc	Min	Typical
			Max
Voltage supply "Vcc" (5)	Vdc	10	12/24/48
Current "Icc"	A	-	8
Standby power "Wo"	W	-	1
Speed setting	rpm	0 / 23,2	-
Torque setting	Nm	0,2	-
Holding torque setting	Nm	0,2	-

Input datas				
Parameters				
Impedance - Input 1, 2	kΩ	Min	Typical	Max
Impedance - Input 3, 4	kΩ	-	57	-
Low level - Input 1, 2	Vdc	0	-	2
High level - Input 1, 2	Vdc	4	-	60
Voltage level - Input 3, 4	Vdc	0	0/10	50
	Vdc			
	Hz			
Output datas				
Parameters				
Low level Outputs	Vdc	Min	Typical	Max
with "pull down resistor" = 4,7KΩ and Vcc = 24 V		0	-	0,2
High level Outputs	Vdc	Vcc - 0,5	-	Vcc
with "pull down resistor" = 4,7KΩ and Vcc = 24 V				
= voltage supply added from eventual rejective voltage				
Notes				
Outputs are destroyed if they are connected to zero ground or to a capacitive load				

Speed-torque and current-torque curves

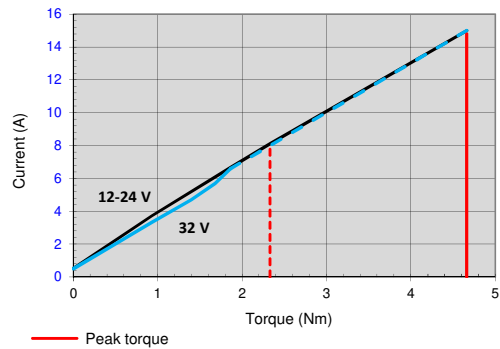
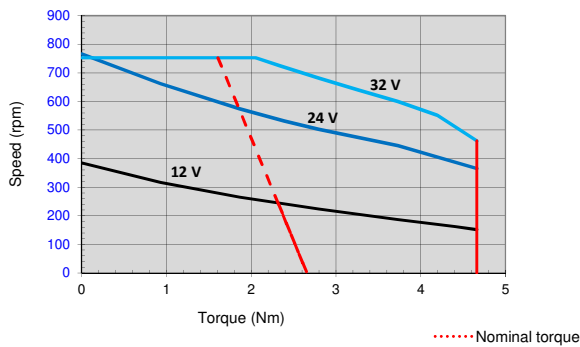

Wiring

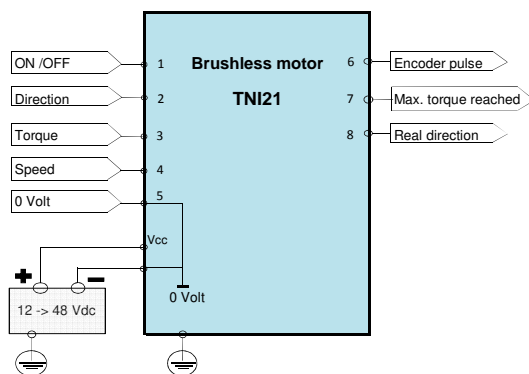

Output equivalent circuit

Outputs

PNP open collector output with internal current limitation (50mA)
Add a pull down resistor

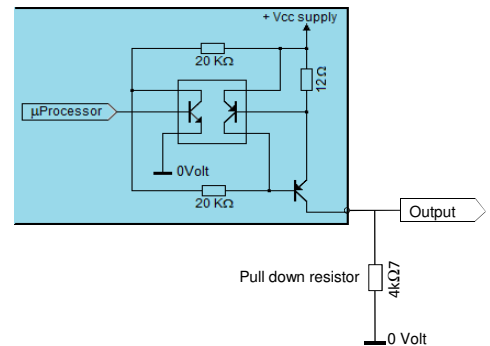

Input equivalent circuits

Inputs: ON/OFF and Direction

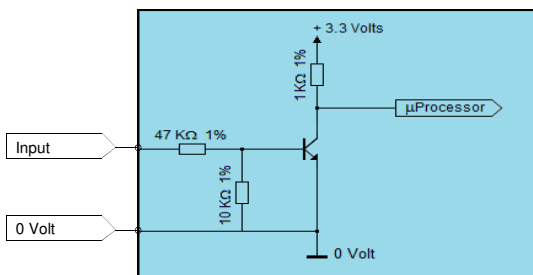

Inputs: Torque and Speed

