



Chipsmall Limited consists of a professional team with an average of over 10 year of expertise in the distribution of electronic components. Based in Hongkong, we have already established firm and mutual-benefit business relationships with customers from,Europe,America and south Asia,supplying obsolete and hard-to-find components to meet their specific needs.

With the principle of "Quality Parts,Customers Priority,Honest Operation,and Considerate Service",our business mainly focus on the distribution of electronic components. Line cards we deal with include Microchip,ALPS,ROHM,Xilinx,Pulse,ON,Everlight and Freescale. Main products comprise IC,Modules,Potentiometer,IC Socket,Relay,Connector.Our parts cover such applications as commercial,industrial, and automotives areas.

We are looking forward to setting up business relationship with you and hope to provide you with the best service and solution. Let us make a better world for our industry!



Contact us

Tel: +86-755-8981 8866 Fax: +86-755-8427 6832

Email & Skype: info@chipsmall.com Web: www.chipsmall.com

Address: A1208, Overseas Decoration Building, #122 Zhenhua RD., Futian, Shenzhen, China



ELEV-8 Power Distribution Board (#80361)

The ELEV-8 Power Distribution Board (PDB) allows the user to interconnect the ELEV-8 v3 power sources and sinks in a compact yet high-capacity form-factor. Designed for use in the ELEV-8 v3 Quadcopter with 1 to 2 batteries and up to 4 *additional* peripheral (low power) devices, this board will keep your project well organized and energized!

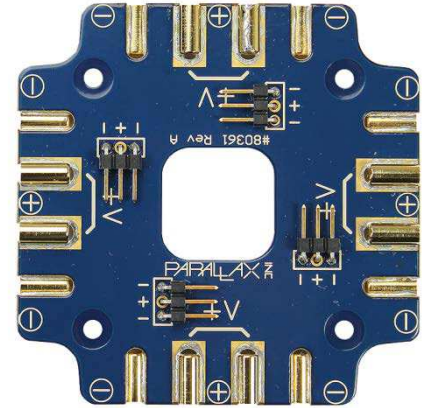

Features

- Fully Assembled – no soldering required!
- Extra connections to power accessories
- Unique shape cleanly mounts and stacks with many multirotor components
- Accepts 3.5 mm bullet connectors that remove easily, yet provide high-capacity secure connections – great for constantly evolving projects
- Reflow manufacturing process ensures all connectors are securely attached for superior electrical performance and mechanical strength

Specifications

- Maximum current ratings: 60 amps continuous*; 100 amps for 15 seconds peak*
- Voltage: 0-18 VDC
- Outer dimensions: 2.8 x 2.8 x 0.32 in (72 x 72 x 8.2 mm)
- Weight: 1.0 oz (28 g)
- Connectors:
 - (8 pair) 3.5 female bullet sockets (gold-plated copper)
 - (4) 3-Pin 0.1" right-angle header (center pin is positive, outer pins are negative)
- Copper thickness: 4 oz/ft² or 0.0056 inches (0.14 mm) on each side
- ROHS Compliant & Lead-Free

* These ratings are approximate and are greatly affected by the specific operating parameters. The ELEV-8 Power Distribution Board is only rated for use within the ELEV-8 v3 Quadcopter, and in accordance with all safety and usage guidelines and instructions.

Notice of Risk & Disclaimer of Liability

NOTICE OF RISK. Use of the ELEV-8 Power Distribution Board (PDB) can at times involve substantial risk of injury, property damage, and other dangers. Dangers peculiar to such activities include, but are not limited to: electrical shock, electrical sparking & arcing, reversed polarity, electrical short, burns, fire, and explosion. *By keeping and using this product, you assume these risks.*

DISCLAIMER OF LIABILITY: In no event shall Parallax Inc. be liable for any direct, indirect, punitive, incidental, special, or consequential damages, to property or life, whatsoever arising out of or connected with the use or misuse of our products. Your purchase or use of this product constitutes your agreement to hereafter assume full and total responsibility for your subsequent utilization of the ELEV-8 Power Distribution Board and you agree to defend, protect, save harmless, and indemnify Parallax Inc., its officers, and employees relative to your potential use and misuse of this product.

Safety Warnings and Guidelines

- **WARNING: ELECTRIC SHOCK HAZARD.** Never contact (directly or indirectly, especially with a conductive object) any uninsulated or inadequately insulated components that may be energized (always assume everything is energized when power is connected).
- **WARNING: HOT. Do not touch during or shortly after operation.** The ELEV-8 Power Distribution Board may become hot during operation, which could cause damage to nearby property (especially if flammable or low melting point) or burn injuries. Always let your ELEV-8 Power Distribution Board cool down to room temperature before handling.
- **This device has no mechanical or electrical protection to prevent reversed polarity.** Always pay careful attention to polarity indicators on device. The user is responsible for any injury or damage caused by reversing the polarity of connected devices.
- **Do not enclose or thermally isolate the ELEV-8 Power Distribution Board.** It must be exposed to constant airflow or other cooling method, or else it may overheat, resulting in property damage or injury.
- **The ELEV-8 Power Distribution Board has exposed terminals.** It is the user's responsibility to adequately insulate all components to prevent electrical shorting and electrical shock
- **Only use compatible and properly insulated connectors rated for high current supplied by Parallax.** Do not use connectors that are loose-fitting, uninsulated, or inadequately rated for your application.
- **KEEP DRY.** Do not expose the ELEV-8 Power Distribution Board to wet or corrosive environments, extreme temperatures (below 0 °C or above 50 °C), flammable or volatile materials, impact or any other damage.
- **Do not modify the ELEV-8 Power Distribution Board.** This includes, but is not limited to, soldering, drilling, and cutting.

Bill of Materials

The ELEV-8 Power Distribution Board comes fully assembled from the following components:

Part #	Quantity	Description
300-80361	1	ELEV-8 Power Distribution Board Raw PCB
450-00053	16	3.5mm Bullet Connector Socket, Gold-Plated Copper
450-00150	4	3-Pin Right-Angle Header, 0.1" spacing, through-hole, solder bearing

Additional Items Required

Will vary with application. All items listed below are included with the ELEV-8 v3 Quadcopter Kit (#80300)

- Power Adapter Cable, such as [ELEV-8 EC3 to 3.5 Bullet Connector Power Cable](#) (# 800-80300)
- Devices with 3.5mm Male Bullet Connectors, such as [Parallax xRotor 20A ESC](#) (# 750-90015)
- 3-Wire Extension Cables or 3-Pin Female Header w/ 0.1" pin spacing
- Safety Glasses (# 700-10003)

Resources and Downloads

Documentation (including the latest version of this document) and open-source design files are available from the [ELEV-8 Power Distribution Board](#) product page. Go to www.parallax.com and search 80361.

Connection Diagram

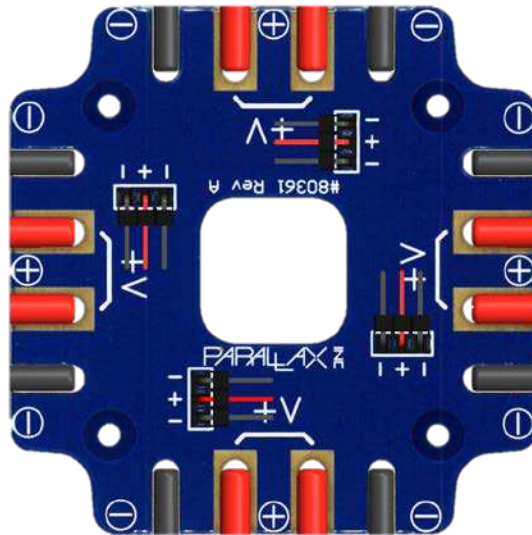

Drawing 1. False-color drawing indicating the polarity of each connector, where red indicates positive and black indicates negative.

Dimensional Drawing

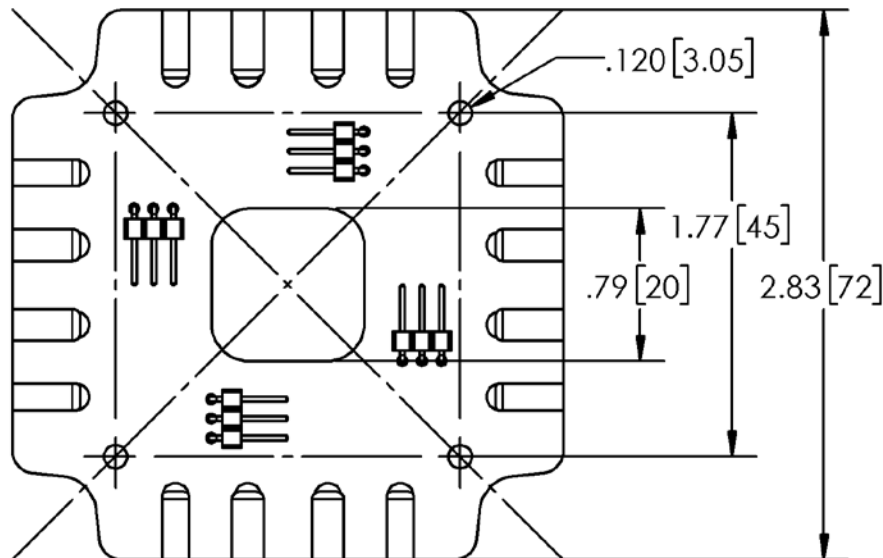

Drawing 2: Dimensional drawing; standard units are inches, [] are mm

License

Copyright 2015-2016 by Parallax Incorporated. The Parallax ELEV-8 Power Distribution Board (#80361) is licensed under the Creative Commons Attribution-ShareAlike 4.0 International License. To view a copy of this license, visit <http://creativecommons.org/licenses/by-sa/4.0/>.

The ELEV-8 Power Distribution Board is [Open-Source Hardware](#). See the “Resources and Downloads” section for information on how to access design materials.



Revision History

Version 1.0 – Initial Release