



Chipsmall Limited consists of a professional team with an average of over 10 year of expertise in the distribution of electronic components. Based in Hongkong, we have already established firm and mutual-benefit business relationships with customers from,Europe,America and south Asia,supplying obsolete and hard-to-find components to meet their specific needs.

With the principle of “Quality Parts,Customers Priority,Honest Operation,and Considerate Service”,our business mainly focus on the distribution of electronic components. Line cards we deal with include Microchip,ALPS,ROHM,Xilinx,Pulse,ON,Everlight and Freescale. Main products comprise IC,Modules,Potentiometer,IC Socket,Relay,Connector.Our parts cover such applications as commercial,industrial, and automotives areas.

We are looking forward to setting up business relationship with you and hope to provide you with the best service and solution. Let us make a better world for our industry!



Contact us

Tel: +86-755-8981 8866 Fax: +86-755-8427 6832

Email & Skype: info@chipsmall.com Web: www.chipsmall.com

Address: A1208, Overseas Decoration Building, #122 Zhenhua RD., Futian, Shenzhen, China





10-Quad RapidIO® Switch

Datasheet
80KSW0005

1 Device Overview

The CPS-10Q (80KSW0005) is a serial RapidIO switch whose functionality is central to routing packets for distribution among DSPs, processors, FPGAs, other switches, or any other sRIO-based devices. The CPS-10Q supports serial RapidIO packet switching (unicast, multicast, and an optional broadcast) from any of its 16 input ports to any of its 16 output ports.

2 Features

Interfaces - sRIO

- 40 bidirectional serial RapidIO (sRIO) lanes v 1.3
- Port Speeds selectable: 3.125Gbps, 2.5Gbps, or 1.25Gbps
- All lanes support short haul or long haul reach for each PHY speed
- Configurable port count to up to 16 ports
- Two enhanced quads can be configured as 4 1x ports or 1 4x ports
- Supports standard 4 levels of priority
- Error handling support: It allows error detection, logging and response from all major functional blocks on the device.

Interfaces - I²C

- Provides I²C port for maintenance and error reporting
- Master or Slave Operation
- Master allows power-on configuration from external ROM
- Master mode configuration with external image compressing and checksum

Performance

- 100 Gbps of peak switching bandwidth
- Non-blocking data flow architecture within each sRIO priority
- low latency for all packet length and load condition
- Internal queuing buffer and retransmit buffer
- Standard receiver based physical layer flow control

Features

- Configurable for cut-thru and store-and-forward modes
- Device configurable through any of sRIO ports, I²C, or JTAG
- Packet Trace function: It allows copying or filtering packets on a per-port basis. Each port provides the ability to match the first 160 bits of any packet against up to 4 programmable comparison values to copy the packet to a programmable output trace port or drop it.
- Supports up to 40 simultaneous multicast masks per each port
- Support Broadcast
- Port Loopback Debug Feature
- Software assisted error recovery, supporting hot swap
- Ports may be individually turned off to reduce power
- PMON counters for monitor and diagnostics per port
- Serdes physical diagnostic registers
- Embedded PRBS generation and detection with programmable polynomial cover error rate under all conditions
- 0.13um technology
- Low power dissipation
- Full JTAG Boundary Scan support (IEEE1149.1 & 1149.6)
- Package: FCBGA 676-ball grid array, 27mm x 27mm, 1.0mm ball pitch

3 Block Diagram

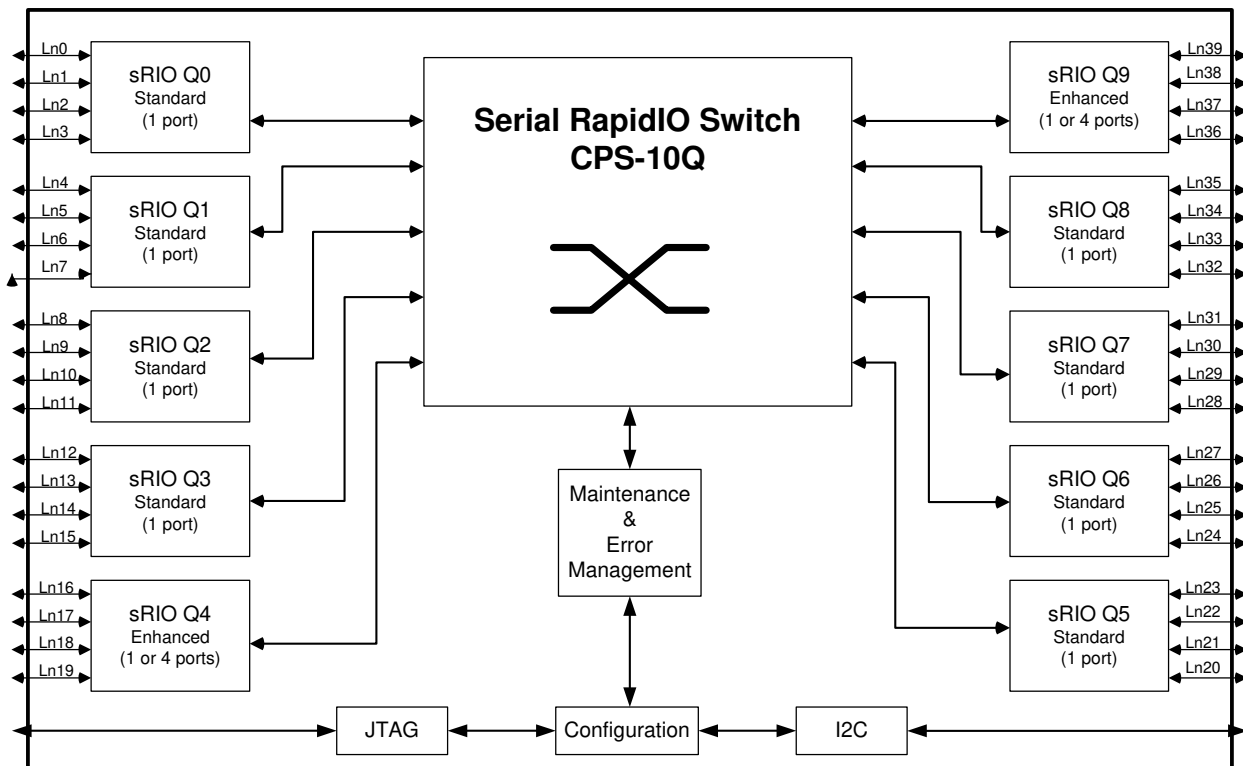

Figure 1 Block diagram

4 Device Description

The CPS-10Q is optimized for cost-effective high performance RapidIO switching, typically used in embedded applications. Typical applications include backplane switching and intensive signal processing where the switch is key to switching on the data path. These applications include wireless infrastructure base station and RNCs, radar and sonar, and medical imaging. It can serve equally as backplane or linecard switch, supporting up to 16 ports. It is an end-point free (switch) device in an sRIO network.

The CPS-10Q receives packets from up to 16 ports. The device offers full support for normal switching as well as enhanced functions:

1) Normal Switching: All packets are switched in accordance with standard serial RapidIO specifications, with packet destination IDs determining how the packet is routed.

Three major options exist within this category:

- a. Multicast: If a Multicast ID is received, the CPS-10Q performs a multicast as defined in the sRIO multicast registers.
- b. Unicast: specified by sRIO.
- c. Maintenance packets: As specified by sRIO.

The CPS-10Q supports a peak throughput of 100 Gbps which is the line rate for 10 ports in 4x configuration, each at 10 Gbps (3.125 Gbps minus the sRIO-defined 8b/10b encoding), and switches dynamically in accordance with the packet headers and priorities.

2) Enhanced functions

Enhanced features are provided for support of system debug. These features which are optional for the user consist of two major functions:

- a. Packet Trace: The Packet Trace feature provides at-speed checking of the first 160 bits (header plus a portion of any payload) of every incoming packet against user-defined comparison register values. The trace feature is available on all serial RapidIO ports, each acting independently from one another. If the trace feature is enabled for a given port, every incoming packet is checked for a match against up to 4 comparison registers. In the event of a match, either of two possible user defined actions may take place:
 - i) not only does the packet route normally through the switch to its appropriate destination port, but this same packet is replicated and sent to a "trace port." The trace port itself may be any of the standard serial RapidIO ports. The port used for the trace port is defined by the user through simple register configuration.
 - ii) the packet is dropped.

If there is no match, the packets route normally through the switch with no action taken.

The Packet Trace feature can be used during system bring-up and prototyping to identify particular packet types of interest to the user. It might be used in security applications, where packets must be checked for either correct or incorrect tags in either of the header or payload. Identified (match) packets are then routed to the trace port for receipt by a host processor, which can perform an intervention at the software level.

- b. Port Loopback: The CPS-10Q offers internal loopback for each port that may be used for system debug of the high speed sRIO ports. By enabling loopback on a given port, packets sent to the port's receiver are immediately looped back at the physical layer to the transmitter - bypassing the higher logical or transport layers.
- c. Broadcast: Each multicast mask can be configured so that the source port is included among the destination ports of that multicast operation.

The CPS-10Q can be programmed through any one or combination of sRIO, I²C, or JTAG. Note that any sRIO port may be used for programming.

The device can also configure itself on power-up by reading directly from ROM over I²C in master mode.

5 Applications

Central switch baseband system wireless processing

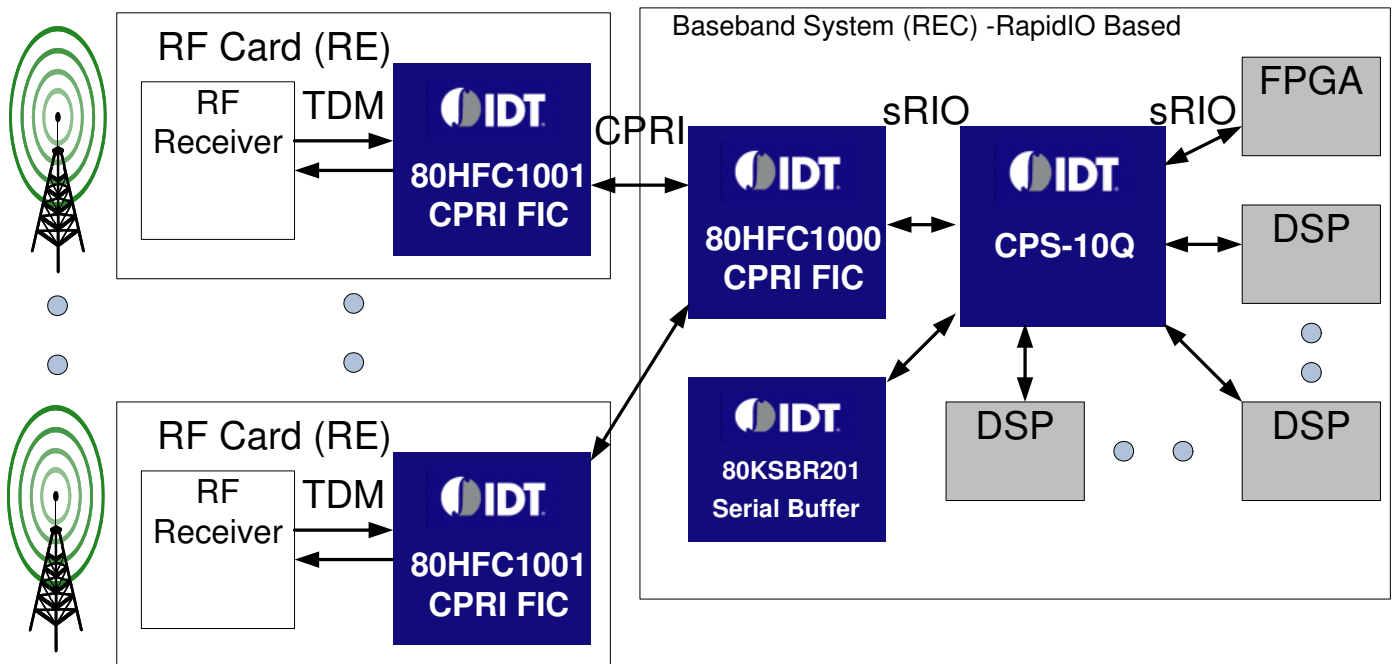

Figure 1 Application Overview

Note: The CPS-10Q provides direct support for backplane connections using the serial RapidIO standard. The addition of an appropriate bridge (e.g., CPRI ↔ sRIO) allows for further backplane flexibility, accommodating designs based on a wide range of standards such as CPRI, OBSAI, GbE or PCIe.

In a macro wireless station, a switch-based raw data combination and distribution architecture is widely adopted. Switch based architecture provides high flexibility and high resource efficiency. The raw data from the Radio Unit is distributed to one or more processing cards by unicast or multicast. Aggregating raw data from processing cards to a buffer-less chain can be done by a fast non-blocking switch.

Media Gateway and general processing

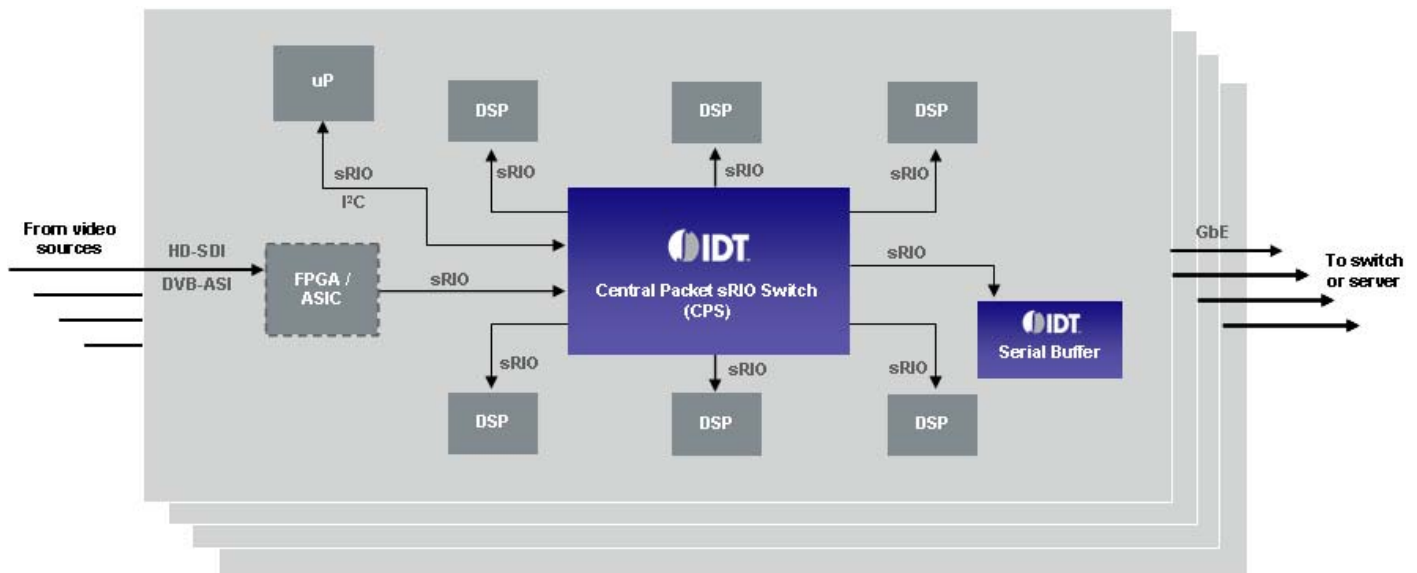

Figure 2 Application Overview

Note: The CPS-10Q provides direct support for backplane connections using the serial RapidIO standard.

A low jitter switch enables fully DSP processing power. Priority support, fast switching, and multicasting will differentiate class of traffic to provide QoS.

6 Functional Overview

The CPS-10Q is optimized for either board-level DSP/ASIC cluster applications or module-level distributed processing application. Up to 16 serial RapidIO ports fully meet standard v1.3. The physical lanes may be configured to operate at 3.125Gbps, 2.5Gbps or 1.25Gbps. All lanes independently work in short haul or long haul. The switch has a sustained 80Gbps bandwidth. It is non-blocking within a given sRIO priority.

The CPS-10Q can be programmed through a CPU or a DSP connected to one of the sRIO ports of the device or with a CPU connected to an I²C or JTAG bus, it can also work along with a I²C configuration memory. This option allows the device work in “remote stand alone” mode.

Each sRIO port provides a packet trace capability. For any packet received by a port, a comparison between the first 160 bits and up to four configurable values can be performed. A match against any of these parameters will result in a copy of the packet and a route of the packet to a configurable output port. This feature can be used as a tactical function to track user data or in a debug environment to test how specific packets are moving through the platform.

7 Interfaces Overview

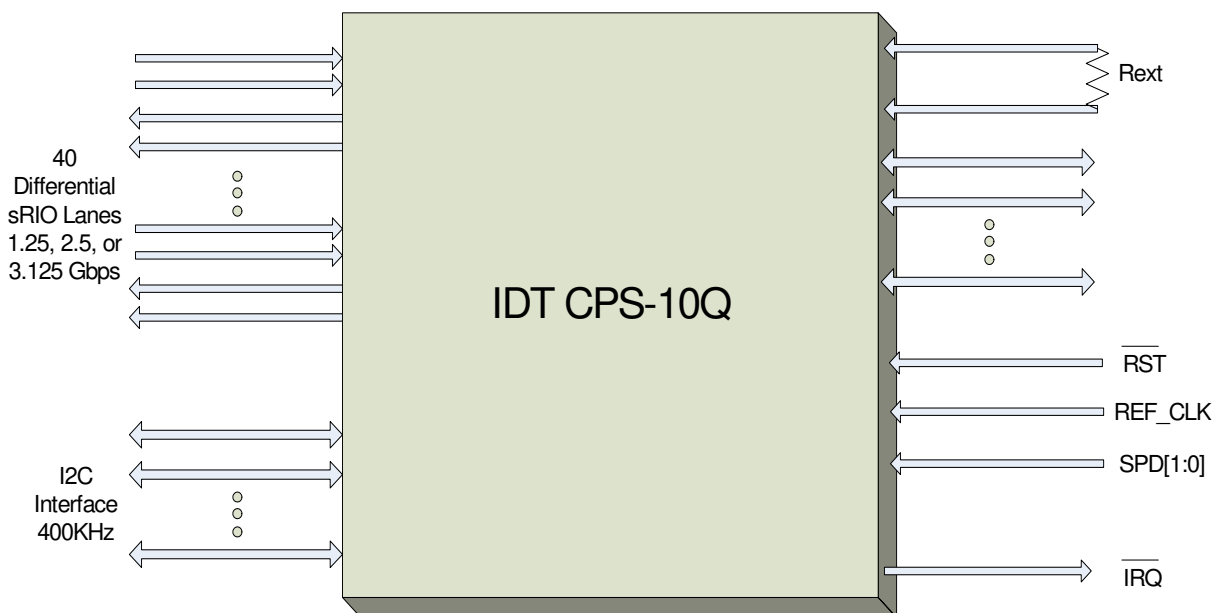

Figure 3 Interface Diagram

sRIO Ports

The sRIO interfaces are the main communication ports on the switch. These ports are compliant with the serial RapidIO v. 1.3 specifications. Please refer to the serial RapidIO specifications for full detail [2-10].

The CPS-10Q provides 40 differential dual simplex transceivers dedicated to sRIO I/O. In addition to standard quads that act as a single 1x or 4x port, two enhanced quads can be independently configured to run in various configurations as 4 1x-ports or 1 4x-ports. The device supports a maximum of 16 1x-ports, or 10 4x-ports. Each port can be programmed to run independently at 1.25, 2.5, or 3.125Gbps. Each lane is able to handle long- or short-haul serial transmission per RIO serial spec.

In the CPS-10Q there are 8 “Standard Quads” which follow the standard sRIO physical interface implementation. These ports either operate in 4x-mode or as a single 1x-port. For example Lanes 0 - 3 are programmable into one 4x- or one 1x-port. Per sRIO standard, either the 1st or 3rd lanes in a given 4x group may be used as a valid link for a 1x port. For example, either lane 0 or lane 2 may be connected in support of a 1x-port.

The CPS-10Q also has a proprietary implementation which we refer to as an “Enhanced Quad” for Quad4 and Quad9. An Enhanced Quad can be operated in standard sRIO mode like the standard quads. Additionally the Enhanced Quad can be register-configured to run as 4 independent 1x-ports. In this manner, the user has the flexibility to use one, multiple, or two lanes in 1x-mode. For example, lanes 16 - 19 of the CPS-10Q are programmable into one 4x- or four 1x-ports. This is unlike the standard sRIO port implementation that, when configured as a 1x-port, renders the remaining possible connections unused.

I²C Bus

This interface may be used as an alternative to the standard sRIO or JTAG ports to program the switch and to check the status of registers - including the error reporting registers. It is fully compliant with the I²C specification, it supports master mode and slave mode, also supports both Fast- and Slow-mode buses [1]. Refer to the “I²C” section for full detail.

JTAG TAP Port

This TAP interface is IEEE1149.1 (JTAG) and 1149.6 (AC Extest) compliant [10, 11]. It may also be used as an alternative to the standard sRIO or I²C ports to program the switch and to check the status of registers - including the error reporting registers. It has 5 pins. Refer to the JTAG chapter for full detail.

Interrupt ($\overline{\text{IRQ}}$)

An interrupt output is provided in support of Error Management functionality. This output may be used to flag a host processor in the event of error conditions within the device. Refer to the Error Handling chapter for full detail.

Reset

A single Reset pin is used for full reset of the CPS-10Q, including setting all registers to power-up defaults. Refer to the Reset & Initialization chapter for full detail.

Clock

The single system clock (REF_CLK+ / -) is a 156.25MHz differential clock.

Rext (Rextn & Rextp)

These pins are used to establish the drive bias on the SerDes output. An external bias resistor is required. The two pins must be connected to one another with a 12k Ohm resistor. This provides CML driver stability across process and temperature.

SPD[1:0]

Speed Select Pins. These pins define the sRIO port speed at RESET for all ports. The RESET setting may be overridden by subsequent programming of the QUAD_CTRL register. SPD[1:0] = {00 = 1.25G, 01 = 2.5G, 10 = 3.125G, 11 = RESERVED}. These pins must remain STATICALLY BIASED after power-up.

8 Absolute Maximum Ratings⁽¹⁾

Symbol	Rating	Commercial & Industrial	Unit
V _{TERM} (V _{DD3})	V _{DD3} Terminal Voltage with Respect to GND	-0.5 to 3.6	V
V _{TERM} ⁽²⁾ (V _{DD3} -supplied interfaces)	Input or I/O Terminal Voltage with Respect to GND	-0.3 to V _{DD3} +0.3	V
V _{TERM} (V _{DD})	V _{DD} Terminal Voltage with Respect to GND	-0.5 to 1.5	V
V _{TERM} ⁽²⁾ (V _{DD} -supplied interfaces)	Input or I/O Terminal Voltage with Respect to GND	-0.3 to V _{DD} +0.3	V
V _{TERM} (V _{DDS})	V _{DDS} Terminal Voltage with Respect to GND	-0.5 to 1.5	V
V _{TERM} ⁽²⁾ (V _{DDS} -supplied interfaces)	Input or I/O Terminal Voltage with Respect to GNDS	-0.3 to V _{DDS} +0.3	V
V _{TERM} (V _{DDA})	V _{DDA} Terminal Voltage with Respect to GND	-0.5 to 1.5	V
V _{TERM} ⁽²⁾ (V _{DDA} -supplied interfaces)	Input or I/O Terminal Voltage with Respect to GNDS	-0.3 to V _{DDA} +0.3	V
T _{BIAS} ⁽³⁾	Temperature Under Bias	-55 to +125	C
T _{STG}	Storage Temperature	-65 to +150	C
T _{JN}	Junction Temperature	+125	C
I _{OUT} (For V _{DD3} = 3.3V)	DC Output Current	30	mA
I _{OUT} (For V _{DD3} = 2.5V)	DC Output Current	30	mA

Table 1 Absolute Maximum Ratings

Notes:

- Stresses greater than those listed under ABSOLUTE MAXIMUM RATINGS may cause permanent damage to the device. This is a stress rating only and functional operation of the device at these or any other conditions above those indicated in the operational sections of this specification is not implied. Exposure to absolute maximum rating conditions for extended periods may affect reliability.
- This is a steady-state DC parameter that applies after the power supply has reached its nominal operating value. Power sequencing is not necessary; however, the voltage on any Input or I/O pin cannot exceed its corresponding supply voltage during power supply ramp up.
- Ambient Temperature under DC Bias. No AC Conditions.

9 Recommended Temperature and Operating Voltage⁽¹⁾

Grade	Ambient Temperature	Ground ⁽²⁾	Supply Voltage ⁽⁴⁾
Commercial	0°C to 70°C	GND = 0V GNDS = 0V	VDD = 1.2 +/- 5% VDDS = 1.2 +/- 5% VDD3 ⁽³⁾ = 3.3 +/- 5% or 2.5V +/- 100mV VDDA = 1.2 +/- 5%
Industrial	-40°C to 85°C	GND = 0V GNDS = 0V	VDD = 1.2 +/- 5% VDDS = 1.2 +/- 5% VDD3 ⁽³⁾ = 3.3 +/- 5% or 2.5V +/- 100mV VDDA = 1.2 +/- 5%

Table 2 Recommended Temperature and Operating Voltage

Notes:

- Power sequencing is not necessary; however, the voltage on any Input or I/O pin cannot exceed its corresponding supply voltage during power supply ramp up. The device is not sensitive to supply rise and fall times, and thus these are not specified.
- VDD3, VDDA, and VDDS share a common ground (GNDS). Core supply and ground are VDD and GND respectively.
- VDD3 may be operated at either 3.3V or 2.5V simply by providing that supply voltage. For those interfaces operating on this supply, this datasheet provides input and output specifications at each of these voltages.
- VDDS & VDDA may be tied to a common power plane. VDD (core, digital supply) should have its own supply and plane. A ferrite bead may be used to supply VDDS/ VDDA from VDD. The bead should be chosen to provide a low DC resistance in order to maintain the rail voltage spec. To keep within the specified low VDDA / VDDS limit, a 0.06 Ohm (DC) resistance is the max allowable. A bead with 10 Ohm impedance provides sufficient AC block while still meeting DC resistance requirements.

10 AC Test Conditions

Input Pulse Levels	GND to 3.0V / GND to 2.4V
Input Rise / Fall Times	2ns
Input Timing Reference Levels	1.5V / 1.25V
Output Reference Levels	1.5V / 1.25V
Output Load	Figures 4

Table 3 AC Test Conditions ($V_{DD3}=3.3V / 2.5V$): JTAG, I²C, RST

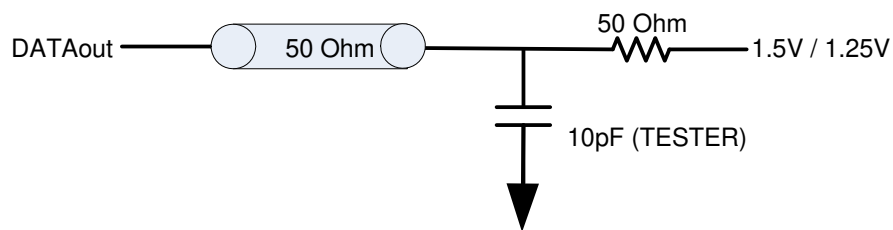

Figure 4 AC Output Test Load (JTAG)

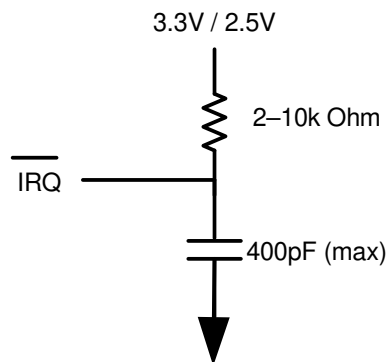

Figure 5 AC Output Test Load (\overline{IRQ})

Note: The \overline{IRQ} pin is an open-drain driver. IDT recommends a weak pull-up resistor (2-10k Ohm) be placed on this pin to V_{DD3} .

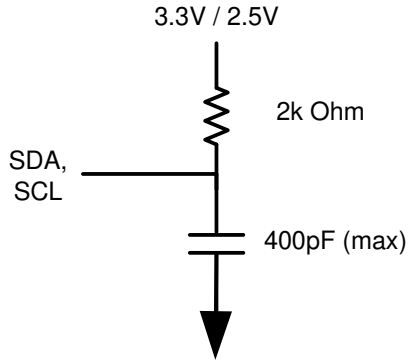

Figure 6 AC Output Test Load (I²C)

Note: The SDA and SCL pins are open-drain drivers. Refer to the Philips I²C specification [1] for appropriate selection of pull-up resistors for each.

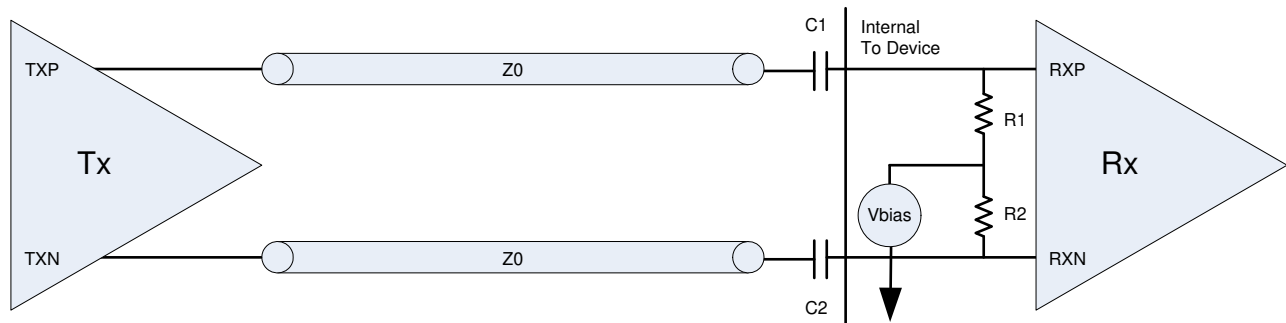

Figure 7 sRIO Lanes Test Load

The characteristic impedance Z_0 should be designed for 100 Ohms. An inline capacitor C_1 and C_2 at each input of the receiver provides AC-coupling and a DC-block. The IDT recommended and test value is 100nF for each. Thus, any DC bias differential between the two devices on the link is negated. The differential input resistance at the receiver is designed to be 100 Ohms (per sRIO specification). Thus, R_1 and R_2 are 50 Ohms each. Note that V_{BIAS} is the internal bias voltage of the device's receiver.

11 Device Performance Figures

11.1 Performance Figures

The following table lists the CPS-10Q's performance figures. Figures provided here are guaranteed by design and characterization, but are not production tested.

Description	Min	Typ	Max	Units	Comments
Throughput (Peak)	—	—	100	Gbps	
Throughput (Sustained)	—	80	—	Gbps	Value shown is for device configured for 10 4X ports, each running at 3.125Gbps, 276 byte packets at priority 0. Please contact IDT technical support for figures related to a specific usage case and traffic conditions.
Per Port throughput (Peak)	—	—	10	Gbps	Value shown is for device configured for each port with 4X 3.125G mode. The sustained throughput is shown in other table below.
Switch Latency Jitter (70% switch load) ⁽²⁾	—	60	—	ns	Latency Jitter for the switch lock is the sum of the Physical layer jitter plus one maintenance packet of contention delay for a given output port. Worst case for the physical layer is the jitter caused by the port sync process. This requires 6 32-bit control symbols plus 2 cycle times the port rate. The figures shown here are for priority 2 packets under 70% switch loading with an even mix of packets of each priority. It assumes that no maintenance packets contend on the output port.
Soft Reset to Receipt of Valid Packets	—	—	26	us	This includes reset time as well as link establishment.
Hard Reset to Receipt of Valid Packets	—	—	26	us	This includes reset time as well as link establishment.
Multicast Map Update Delay	25	—	2000	cycles ⁽³⁾	

Table 4 80KSW0005 Performance Figures

Notes:

1. Values are guaranteed by characterization, but are not production tested.
2. For those specifications associated with an sRIO transaction, it should be noted that the upper limit to a specification may be dictated by sRIO priority handling. For example, a maintenance read packet having lower priority may be held off until higher priority packets in queue are serviced. The user should take into consideration this additional priority-induced delay when examining these specifications. I²C and JTAG configuration register access transactions are always deterministic and follow these specifications identically.
3. "Cycles" refer to internal core clock cycles which are two times the external reference clock (REF_CLK) frequency = 312.5 MHz.

11.2 Sustained Per-Port Throughput (Typical)

Pay Load Size	1.25GHz		2.5GHz		3.125GHz	
	1X	4X	1X	4X	1X	4X
16 Byte	0.70 G	2.33 G	1.38 G	4.42 G	1.93 G	4.67
32 Byte	0.79 G	2.4 G	1.57 G	5.48 G	2.1 G	5.89
64 Byte	0.86 G	2.92 G	1.73 G	6.32 G	2.24 G	7.02 G
128 Byte	0.94 G	3.38 G	1.87 G	6.76 G	2.28 G	8.19 G
256 Byte	0.97 G	3.66 G	1.93 G	7.30 G	2.39 G	8.93 G

Table 5 Sustained Per-Port Throughput (Typical)

Notes:

1. Values are guaranteed by characterization, but are not production tested.
2. Throughput values are for 8bit destination ID packet, Header + Pay Load + CRC. The (Header + CRC) size changes depending on payload size. For payloads less than 80 Bytes, the (Header + CRC) is 12 bytes. For payloads bigger than 80 Bytes, the (Header + CRC) is 14 bytes.
3. As payload size increases, the physical layer control symbols (sRIO required overhead) become a smaller percentage of the overall per-port throughput figure. The physical layer symbols include one SoP and one EoP for every packet. There is a status control symbol for every 1024 transmitted code-group as well as synchronization sequences required by sRIO. For two way traffic, packet acknowledgment control symbols will occur between the packets.

11.3 Data Packet Latency in “Store-and-Forward” Mode (Typical)

Pay Load Size	1.25GHz		2.5GHz		3.125GHz	
	1X	4X	1X	4X	1X	4X
8 Byte	454 ns	328 ns	271 ns	228 ns	240 ns	211 ns
16 Byte	518 ns	348 ns	304 ns	234 ns	266 ns	216 ns
32 Byte	646 ns	380 ns	367 ns	246 ns	316 ns	227 ns
64 Byte	905 ns	441 ns	493 ns	271 ns	419 ns	253 ns
128 Byte	1449 ns	580 ns	770 ns	336 ns	641 ns	307 ns
256 Byte	2473 ns	833 ns	1282 ns	457 ns	1049 ns	409 ns
Multicast Event Control Symbol	126 ns	115 ns	66 ns	60 ns	55 ns	49 ns

Table 6 Switch Latency Table (Store-and-Forward Mode, Typical)

Notes:

1. Values are guaranteed by characterization, but are not production tested.
2. For those specifications associated with an sRIO transaction, it should be noted that the upper limit to a specification may be dictated by sRIO priority handling. For example, a maintenance read packet having lower priority may be held off until higher priority packets in queue are serviced. The user should take into consideration this additional priority-induced delay when examining these specifications. I2C and JTAG transactions are always deterministic and follow these specifications identically.
3. Switch latency is a statistical function, which typically increases with increased traffic loading on the switch. Values shown in Table 6 are typical for single input port to single output port with matching input and output port rates in “Store-and-Forward” mode, no other switch loading. The switch latency in “Store-and-Forward” packet forward methodology is also a strong function of port rate. For specific values under other specific application usage scenarios and traffic conditions, please contact IDT technical support.

11.4 Data Packet Latency in “Cut-Through” Mode (Typical)

Pay Load Size	1.25GHz		2.5GHz		3.125GHz	
	1X	4X	1X	4X	1X	4X
8 Byte	369 ns	322 ns	233 ns	217 ns	205 ns	195 ns
16 Byte	366 ns	320 ns	225 ns	217 ns	204 ns	197 ns
32 Byte	354 ns	320 ns	224 ns	218 ns	204 ns	195 ns
64 Byte	351 ns	322 ns	223 ns	220 ns	203 ns	196 ns
128 Byte	351 ns	318 ns	224 ns	218 ns	203 ns	196 ns
256 Byte	351 ns	317 ns	222 ns	216 ns	205 ns	195 ns

Table 7 Switch Latency Table (Cut-Through Mode)

Note:

1. Values shown in Table 7 are typical for single input port to single output port with matching input and output port rates in “Cut-Through” mode, no other switch loading. For specific values under other specific application usage scenarios and traffic conditions, please contact IDT technical support.

In “Store-and-Forward” mode and “Cut-Through” mode when trace and filter are enabled at the same time, only the latency for packets sending to the trace port will increase by the time taken to send 20 bytes into the port ($20\text{bytes} * 1/[\text{port_speed} * 0.8]$) The latency for other traffic flow will be unaffected.

11.5 Maintenance Packet Latency (Typical)

Mode	1.25GHz		2.5GHz		3.125GHz	
	1X	4X	1X	4X	1X	4X
Store-and-forward	571 ns	460 ns	395 ns	344 ns	352 ns	315 ns
Cut-Through	566 ns	449 ns	386 ns	334 ns	344 ns	315 ns

Table 8 Maintenance Packet (20 words) Latency

Note:

1. Values are guaranteed by characterization, but are not production tested.

11.6 Doorbell packet latency (Typical)

Mode	1.25GHz		2.5GHz		3.125GHz	
	1X	4X	1X	4X	1X	4X
Store-and-forward	395 ns	323 ns	246 ns	225 ns	219 ns	208 ns
Cut-Through	378 ns	317 ns	230 ns	221 ns	209 ns	208 ns

Table 9 Doorbell Packet Latency

Note:

1. Values are guaranteed by characterization, but are not production tested.

12 Power Figures

Typical power draw for the 80KSW0005 is approximately 5.3W total for all ports enabled as 10 4x @ 3.125G under 50% switch load. The following table provides power figures on a per-block basis. An estimate of the device power figure for a given application usage can be determined by using the "CPS-10Q Power Calculator" modeling tool.

Description	Typical	Units	Supply	Comments
Serdes 1x @ 1.25G	66, 33	mW	VDDS, VDDA	Analog SerDes power consumption (VDDS and VDDA). This does not include the sRIO quad power consumption.
SerDes 1x @ 2.5G	78, 36	mW	VDDS, VDDA	Analog SerDes power consumption (VDDS and VDDA). This does not include the sRIO quad power consumption.
SerDes 1x @ 3.125G	82, 49	mW	VDDS, VDDA	Analog SerDes power consumption (VDDS and VDDA). This does not include the sRIO quad power consumption.
Serdes 4x @ 1.25G	149, 226	mW	VDDS, VDDA	Analog SerDes power consumption (VDDS and VDDA). This does not include the sRIO quad power consumption.
SerDes 4x @ 2.5G	178, 82	mW	VDDS, VDDA	Analog SerDes power consumption (VDDS and VDDA). This does not include the sRIO quad power consumption.
SerDes 4x @ 3.125G	187, 110	mW	VDDS, VDDA	Analog SerDes power consumption (VDDS and VDDA). This does not include the sRIO quad power consumption.
JTAG Block Enable	100	mW	VDD3	Configuration Register Access only. Max interface speed(10MHz).
I2C Block Enable	86	mW	VDD3	Configuration Register Access only. Max interface speed (400KHz).
Quiescent Power	1700	mW	VDD	Minimum possible operational power draw. All ports disable, I2C and JTAG signals static.
Quiescent Power	86	mW	VDD3	Minimum possible operational power draw. All ports disable, I2C and JTAG signals static.
Quiescent Power	75, 47	mW	VDDS, VDDA	Minimum possible operational power draw. All ports disable, I2C and JTAG signals static.
Reset Power	15	mW	VDD	Peak power during RESET of the device.
Reset Power	32	mW	VDD3	Peak power during RESET of the device.
Reset Power	8, 39	mW	VDDS, VDDA	Peak power during RESET of the device.
Standby Power @1.25G	2000	mW	VDD	Part powered up, reset, all links up (reset configuration), no traffic
Standby Power @1.25G	86	mW	VDD3	Part powered up, reset, all links up (reset configuration), no traffic
Standby Power @1.25G	1700, 1000	mW	VDDS, VDDA	Part powered up, reset, all links up (reset configuration), no traffic
Standby Power @2.5G	2200	mW	VDD	Part powered up, reset, all links up (reset configuration), no traffic
Standby Power @2.5G	86	mW	VDD3	Part powered up, reset, all links up (reset configuration), no traffic
Standby Power @2.5G	2000, 1000	mW	VDDS, VDDA	Part powered up, reset, all links up (reset configuration), no traffic
Standby Power @3.125G	2200	mW	VDD	Part powered up, reset, all links up (reset configuration), no traffic
Standby Power @3.125G	86	mW	VDD3	Part powered up, reset, all links up (reset configuration), no traffic
Standby Power @3.125G	2200, 1300	mW	VDDS, VDDA	Part powered up, reset, all links up (reset configuration), no traffic
Peak sustained Power	2500	mW	VDD	All sRIO ports enabled at maximum speed, maximum traffic to the switch.
Peak sustained Power	100	mW	VDD3	All sRIO ports enabled at maximum speed, maximum traffic to the switch.
Peak sustained Power	2300, 1500	mW	VDDS, VDDA	All sRIO ports enabled at maximum speed, maximum traffic to the switch

Table 10 Typical Power Figures

Condition: VDD = 1.2V, VDDS = 1.2V, VDDA = 1.2V, VDD3 = 3.3V @ Room temperature 25°C

Worst power draw for the 80KSW0005 is approximately 7W total. The condition is all ports @ 3.125G under 100% switch load at the max driving strength and all trace function are enable.

13 I²C-Bus

The CPS-10Q is compliant with the I²C specification [1]. This specification provides all functional detail and electrical specifications associated with the I²C bus. This includes signaling, addressing, arbitration, AC timing, DC specifications, and other details.

The device supports both master mode and slave mode, it's selected by MM pin.

The I²C bus is comprised of Serial Data (SDA) and Serial Clock (SCL) pins. It can be used to attach a CPU or a configuration memory. The I²C interface supports Fast/Standard (F/S) mode (400/ 100 kHz).

I²C master mode and slave mode

The CPS-10Q devices support both master mode and slave mode. It's selected by MM static configuration pin. Refer to the below for signaling and operation.

I²C Device Address

The device address for the CPS-10Q is fully pin-defined by 10 external pins while in slave mode. This provides full flexibility in defining the slave address to avoid conflicting with other I²C devices on a given bus. The device can be operated as either a 10-bit addressable device or a 7-bit addressable device based on another external pin, address select (ADS). If the ADS pin is tied to VDD, then the CPS-10Q operates as a 10-bit addressable device and the device address will be defined as ID[9:0]. If the ADS pin is tied to GND, then the device operates as a 7-bit addressable device with the device address defined by ID[6:0]. The addressing mode must be established at power-up and remain static throughout operation. Dynamic changes will result in undetermined behavior.

Pin	I ² C Address Bit (pin_addr)
ID0	0
ID1	1
ID2	2
ID3	3
ID4	4
ID5	5
ID6	6
ID7	7 (don't care in 7-bit mode)
ID8	8 (don't care in 7-bit mode)
ID9	9 (don't care in 7-bit mode)

Table 11 I²C Static Address Selection Pin Configuration

All of the CPS-10Q's registers are addressable through I²C. These registers are accessed via 22-bit addresses and 32-bit word boundaries though standard reads and writes. These registers may also be accessed through the sRIO and JTAG interfaces.

Signaling

Communication with the CPS-10Q on the I²C bus follows these three cases:

- 1) Suppose a master device wants to send information to the CPS-10Q:
 - Master device addresses CPS-10Q (slave)
 - Master device (master-transmitter), sends data to CPS-10Q (slave- receiver)
 - Master device terminates the transfer

- 2) If a master device wants to receive information from the CPS-10Q:
 - Master device addresses CPS-10Q (slave)
 - Master device (master-receiver) receives data from CPS-10Q (slave- transmitter)
 - Master device terminates the transfer.

- 3) If CPS-10Q polls configuration image from external memory
 - CPS-10Q addresses the memory.
 - Memory transmits the data.
 - CPS-10Q gets the data.

All signaling is fully compliant with I²C. Full detail of signaling can be found in the Philips I²C specification [1]. Standard signaling and timing waveforms are shown below.

Interfacing to Standard-, Fast-, and Hs-mode Devices

The CPS-10Q supports Fast / Standard (F/S) modes of operation. Per I²C specification, in mixed speed communication the CPS-10Q supports Hs- and Fast-mode devices at 400 kbit/s, and Standard-mode devices at 100 kbit/s. Please refer to the I²C specification for detail on speed negotiation on a mixed speed bus.

CPS-10Q-Specific Memory Access (Slave mode)

There is a CPS-10Q-specific I²C memory access implementation. This implementation is fully I²C compliant. It requires the memory address to be explicitly specified during writes. This provides directed memory accesses through the I²C bus. Subsequent reads always begin at the address specified during the last write.

The write procedure requires the 3-Bytes (22-bits) of memory address to be provided following the device address. Thus, the following are required: device address – one or two bytes depending on 10-bit / 7-bit addressing, memory address – 3 bytes yielding 22-bits of memory address, and a 32-bit data payload – 4 byte words. To remain consistent with sRIO standard maintenance packet memory address convention, the I²C memory address provided must be the 22MSBs. Since I²C writes to memory apply to double words (32-bits), the 2 LSBs are DON'T CARE as the LSBs correspond to word and byte pointers.

The read procedure has the memory address section of the transfer removed. Thus, to perform a read, the proper access would be to perform a write operation and issue a repeated start after the acknowledge bit following the third byte of memory address. Then, the master would issue a read command selecting the CPS-10Q through the standard device address procedure with the R/W bit high. Note that in 10-bit device address mode (ADS=1), only the two MSBs need be provided during this read. Data from the previously loaded address would immediately follow the device address protocol. It is possible to issue a stop or repeated start anytime during the write data payload procedure, but must be before the final acknowledge (i.e. canceling the write before the actual write operation is completed and performed). Also, the master would be allowed to access other devices attached to the I²C bus before returning to select the CPS-10Q for the subsequent read operation from the loaded address.

Read/Write Figures

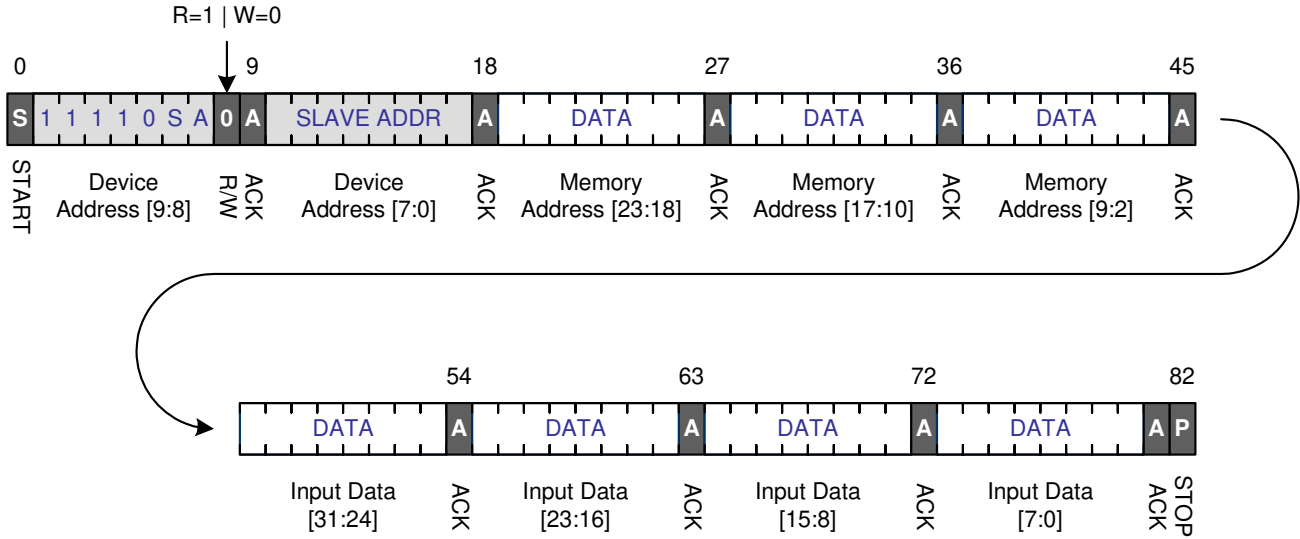

Figure 8 Write protocol with 10-bit Slave Address (ADS=1).

I²C writes to memory align on 32-bit word boundaries, thus the 24 address MSBs must be provided while the 2 LSB's associated with word and byte pointers are DON'T CARE and are therefore not transmitted.

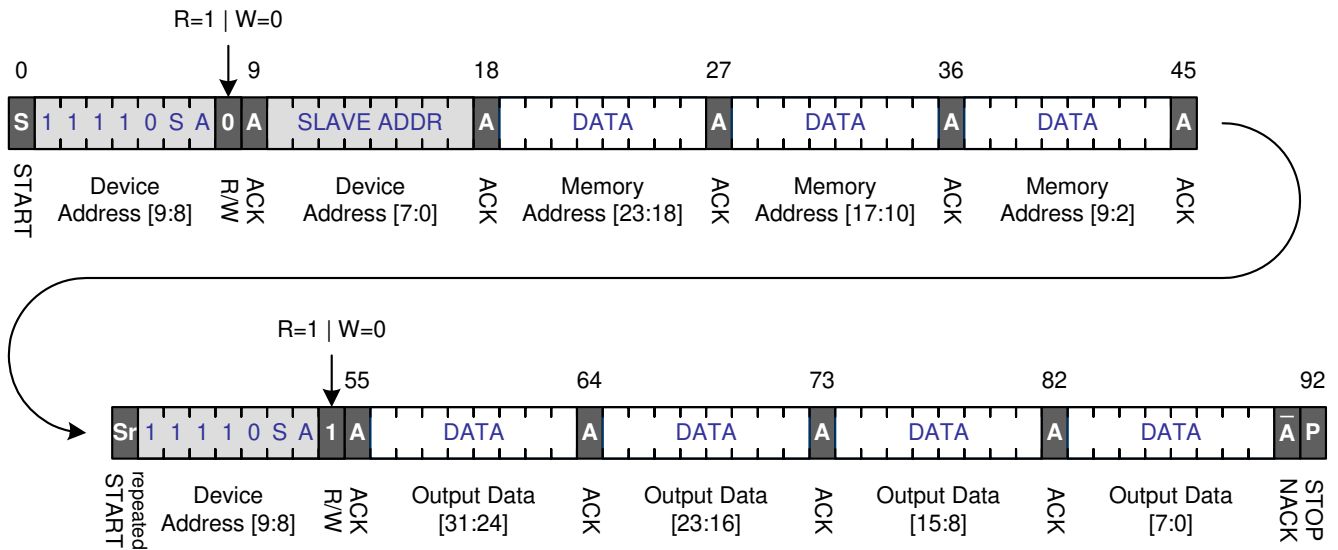

Figure 9 Read Protocol with 10-bit Slave Address (ADS=1)

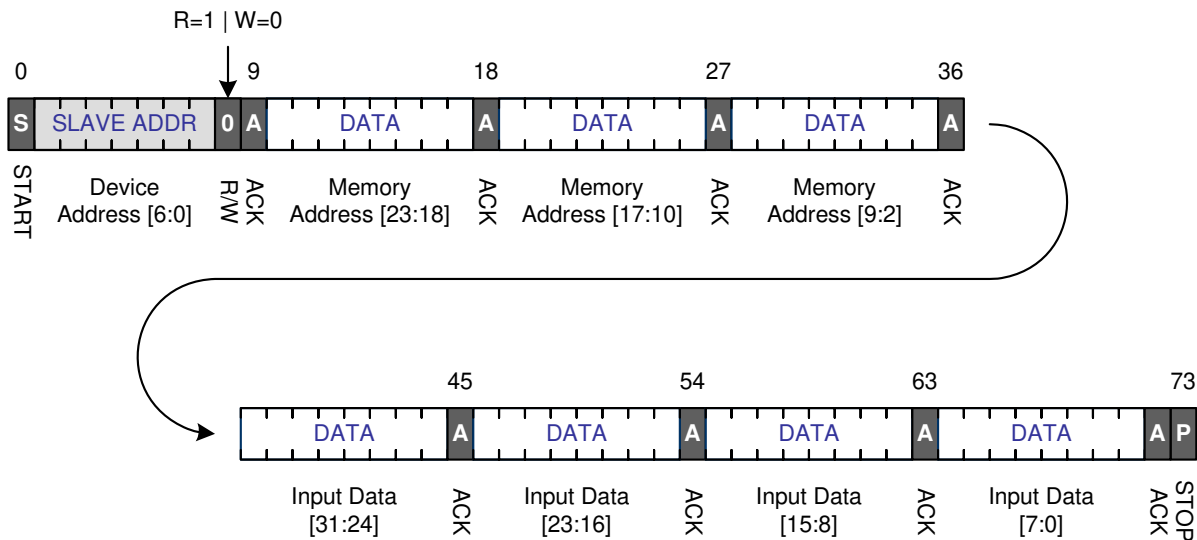

Figure 10 Write protocol with 7-bit Slave Address (ADS=0).

I²C writes to memory align on 32-bit word boundaries, thus the 24 address MSBs must be provided while the 2 LSB's associated with word and byte pointers are DON'T CARE and are therefore not transmitted.

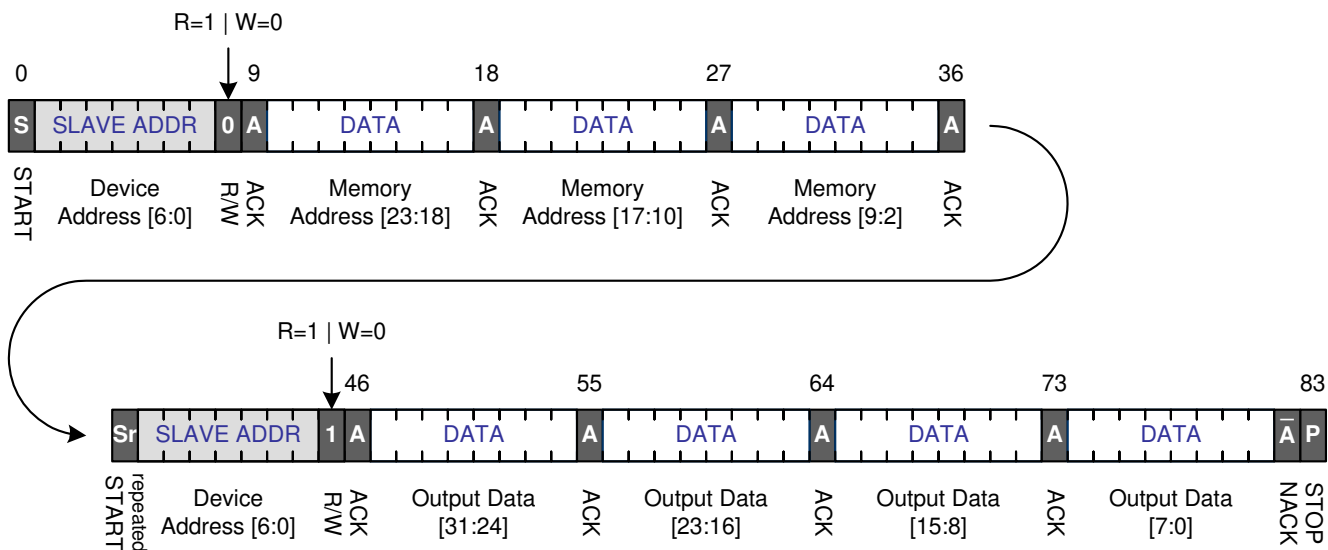

Figure 11 Read protocol with 7-bit Slave Address (ADS=0)

CPS-10Q Configuration and Image (Master mode)

There is both a power up master and a command master mode. If powered up in master mode, the CPS-10Q polls configuration image from external memory after the device reset sequence has completed. Once the device has completed its configuration sequence, it will revert to slave mode. Through a config register write, the device can be commanded to enter master mode, which provides more configuration sequence flexibility. Refer to “CPS-10Q User Manual” for details.

I²C DC Electrical Specifications

Note that the ADS and ID pins will all run off the core (1.2V) power supply, and these pins are required to be fixed during operation. Thus, these pins must be statically tied to the 1.2V supply or GND.

Tables 12 through 14 below list the SDA and SCL electrical specifications for F/S-mode I²C devices.

At recommended operating conditions with VDD3 = 3.3V ± 5%

Parameter	Symbol	Minimum	Maximum	Unit
Input high voltage level	V _{IH}	0.7 x VDD3	VDD3 (MAX)+ 0.5	V
Input low voltage level	V _{IL}	-0.5	0.3 x VDD3	V
Hysteresis of Schmitt trigger inputs:	V _{hys}	0.05 x VDD3	-	
Low level output voltage	V _{OL}	0	0.4	V
Output fall time from V _{IH} (MIN) to V _{IL} (MAX) with a bus capacitance from 10pF to 400pF	t _{OF}	20 + 0.1 x C _b	250	ns
Pulse width of spikes which must be suppressed by the input filter	t _{SP}	0	50	ns
Input current each I/O pin (input voltage is between 0.1 x VDD3 and 0.9 x VDD3 (MAX))	I _I	-10	10	uA
Capacitance for each I/O pin	C _I	-	10	pF

Table 12 I²C SDA & SCL DC Electrical Specifications

At recommended operating conditions with VDD3 = 2.5V ± 100mV

Parameter	Symbol	Minimum	Maximum	Unit
Input high voltage level	V _{IH}	0.7 x VDD3	VDD3 (MAX)+ 0.1	V
Input low voltage level	V _{IL}	-0.5	0.3 x VDD3	V
Hysteresis of Schmitt trigger inputs:	V _{hys}	0.05 x VDD3	-	-
Low level output voltage	V _{OL}	0	0.4	V
Output fall time from V _{IH} (MIN) to V _{IL} (MAX) with a bus capacitance from 10pF to 400pF	t _{OF}	20 + 0.1 x C _b	250	ns
Pulse width of spikes which must be suppressed by the input filter	t _{SP}	0	50	ns
Input current each I/O pin (input voltage is between 0.1 x VDD3 and 0.9 x VDD3 (MAX))	I _I	-10	10	uA
Capacitance for each I/O pin	C _I	-	10	pF

Table 13 I²C SDA & SCL DC Electrical Specifications

I²C AC Electrical Specifications

Signal	Symbol	Reference Edge	Standard Mode		Fast Mode		Unit
			Min	Max	Min	Max	
I ² C ^(1,4)							
SCL	fSCL	none	0	100	0	400	kHz
	t _{HD;STA}		4.0	—	0.6	—	us
	t _R		—	1000	—	300	us
	t _F		—	300	—	300	us
SDA ^(2,3)	t _{SV;DAT}	SCL rising	250	—	100	—	us
	t _{HD;DAT}		0	3.45	0	0.9	us
	t _R		—	1000	10	300	us
	t _F		—	300	10	300	us
Start or repeated start condition	t _{SU;STA}	SDA falling	4.7	—	0.6	—	us
	t _{SU;STO}		4.0	—	0.6	—	us
Stop condition	t _{SU;STO}	SDA rising	4.0	—	0.6	—	us
Bus free time between a stop and start condition	t _{BUF}		4.7	—	1.3	—	us
Capacitive load for each bus line	C _B		—	400	—	400	pF

Table 14 Specifications of the SDA and SCL Bus Lines for F/S-mode I²C -bus Devices

Notes:

- For more information, see the I²C-Bus specification by Philips Semiconductor [1].
- A device must internally provide a hold time of at least 300 ns for the SDA signal (referred to the V_{IHMIn} of the SCL signal) to bridge the undefined region of the falling edge of SCL.
- The maximum t_{HD;DAT} has only to be met if the device does not stretch the LOW period (t_{LOW}) of the SCL signal.
- A Fast-mode I²C-bus device can be used in a Standard-mode I²C-bus system, but the requirement t_{SU;DAT} ≥ 250 ns must then be met. This will automatically be the case if the device does not stretch the LOW period of the SCL signal. If such a device does stretch the LOW period of the SCL signal, it must output the next data bit to the SDA line t_{RMAX} + t_{SU;DAT} = 1000 + 250 = 1250 ns (according to the Standard-mode I²C-bus specification) before the SCL line is released.

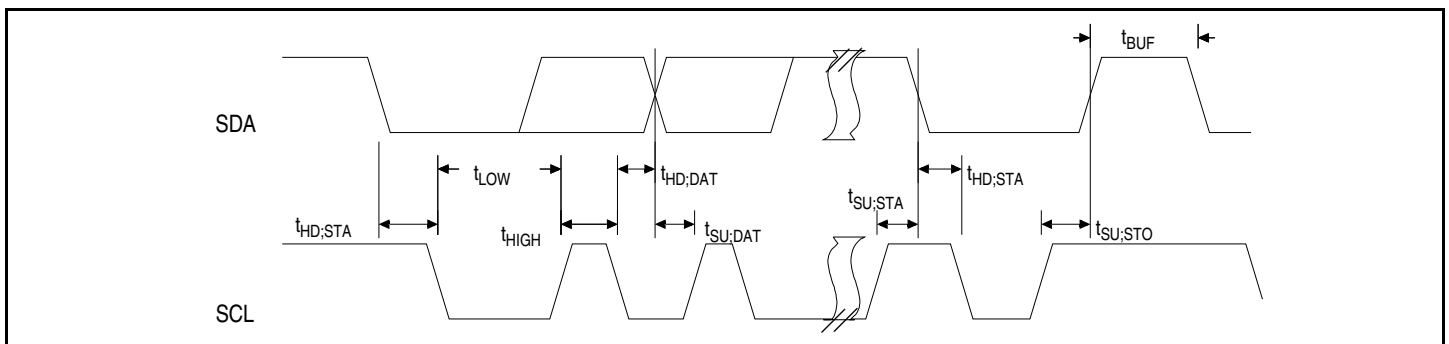
I²C Timing WaveformsFigure 12 I²C Timing Waveforms

14 Interrupt ($\overline{\text{IRQ}}$) Electrical Specifications

At recommended operating conditions with $V_{DD3} = 3.3V \pm 5\%$

Parameter	Symbol	Min	Max	Unit
Output low voltage ($I_{OL} = 4mA$, $V_{DD3} = \text{Min.}$)	V_{OL}	0	0.4	V
Output fall time from $V_{IH(\text{min})}$ to $V_{IL(\text{max})}$ with a bus capacitance from 10pF to 400pF	t_{OF}	-	25	ns
Input current each I/O pin (input voltage is between $0.1 \times V_{DD3}$ and $0.9 \times V_{DD3}$ (max))	I_I	-10	10	μA
Capacitance for $\overline{\text{IRQ_N}}$	C_I	-	10	pF

Table 15 $\overline{\text{IRQ}}$ Electrical Specifications ($V_{DD3} = 3.3V \pm 5\%$)

At recommended operating conditions with $V_{DD3} = 2.5V \pm 100mV$

Parameter	Symbol	Min	Max	Unit
Output low voltage ($I_{OL} = 2mA$, $V_{DD3} = \text{Min.}$)	V_{OL}	0	0.4	V
Output fall time from $V_{IH(\text{min})}$ to $V_{IL(\text{max})}$ with a bus capacitance from 10pF to 400pF	t_{OF}	-	25	ns
Input current each I/O pin (input voltage is between $0.1 \times V_{DD3}$ and $0.9 \times V_{DD3}$ (max))	I_I	-10	10	μA
Capacitance for $\overline{\text{IRQ_N}}$	C_I	-	10	pF

Table 16 $\overline{\text{IRQ}}$ Electrical Specifications ($V_{DD3} = 2.5V \pm 100mV$)

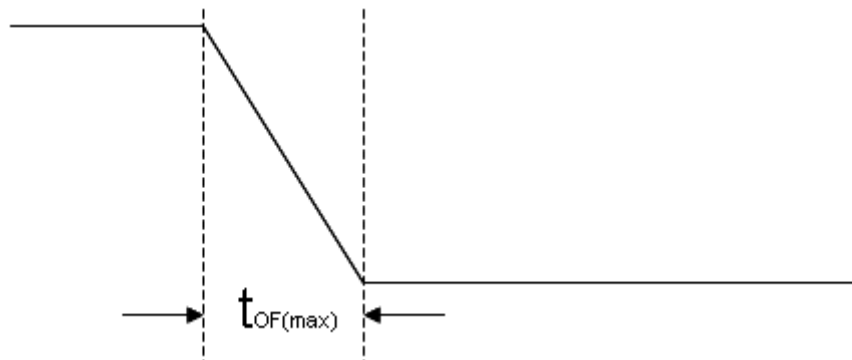

Figure 13 $\overline{\text{IRQ}}$ Timing Diagram

The $\overline{\text{IRQ}}$ pin is an open-drain driver. IDT recommends a weak pull-up resistor (2-10k Ohm) be placed on this pin to V_{DD3} . The $\overline{\text{IRQ}}$ pin goes active low when any special error filter error flag is set, and is cleared when all error flags are reset. Please refer to the device user's manual for full detail.

15 Serial RapidIO Ports

Overview

The CPS-10Q's SERDES are in full compliance to the RapidIO AC specifications for the LP-Serial physical layer [5]. This section provides those specifications for reference. The electrical specifications cover both single and multiple-lane links. Two transmitters (short run and long run) and a single receiver are specified for each of three baud rates, 1.25, 2.50, and 3.125 GBaud.

Two transmitter specifications allow for solutions ranging from simple chip-to-chip interconnect to driving two connectors across a backplane. A single receiver specification is given that will accept signals from both the short run and long run transmitter specifications.

The short run transmitter setting should be used mainly for chip-to-chip connections on either the same printed circuit board or across a single connector. This covers the case where connections are made to a mezzanine (daughter) card. The minimum swings of the short run specification reduce the overall power used by the transceivers.

The long run transmitter specifications use larger voltage swings that are capable of driving signals across backplanes. This allows a user to drive signals across two connectors and a backplane. The CPS-10Q can drive beyond the specification distance of at least 50 cm at all baud rates. Please use IDT's Simulation Kit IO models to determine reach and signal quality for a given PCB design.

Signal Definitions

LP-Serial links uses differential signaling. This section defines terms used in the description and specification of differential signals. Differential Peak-Peak Voltage of Transmitter or Receiver shows how the signals are defined. The figure shows waveforms for either a transmitter output (TD and \overline{TD}) or a receiver input (RD and \overline{RD}). Each signal swings between A Volts and B Volts where $A > B$. Using these waveforms, the definitions are as follows:

1. The transmitter output signals and the receiver input signals TD, \overline{TD} , RD and \overline{RD} each have a peak-to-peak swing of A - B Volts
2. The differential output signal of the transmitter, V_{OD} , is defined as $V_{TD} - V_{\overline{TD}}$.
3. The differential input signal of the receiver, V_{ID} , is defined as $V_{RD} - V_{\overline{RD}}$.
4. The differential output signal of the transmitter and the differential input signal of the receiver each range from A - B to -(A - B) Volts.
5. The peak value of the differential transmitter output signal and the differential receiver input signal is A - B Volts
6. The peak-to-peak value of the differential transmitter output signal and the differential receiver input signal is $2 * (A - B)$ Volts

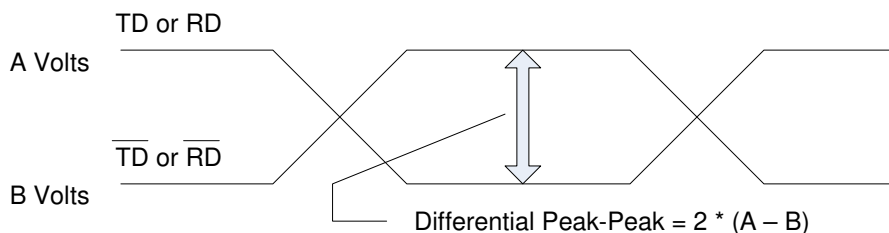

Figure 14 Differential Peak-Peak Voltage of Transmitter or Receiver

To illustrate these definitions using real values, consider the case of a CML (Current Mode Logic) transmitter that has a common mode voltage of 2.25 V and each of its outputs, TD and \overline{TD} , has a swing that goes between 2.5V and 2.0V. Using these values, the peak-to-peak voltage swing of the signals TD and \overline{TD} is 500 mV p-p. The differential output signal ranges between 500 mV and -500 mV. The peak differential voltage is 500 mV. The peak-to-peak differential voltage is 1000 mV p-p.

Equalization

With the use of high speed serial links, the interconnect media will cause degradation of the signal at the receiver. Effects such as Inter-Symbol Interference (ISI) or data dependent jitter are produced. This loss can be large enough to degrade the eye opening at the receiver beyond what is allowed in the specification. To negate a portion of these effects, equalization can be used. The equalization technique implemented in the CPS-10Q is Pre-emphasis on the transmitter (under register control).

Explanatory Note on Transmitter and Receiver Specifications

AC electrical specifications are given for transmitter and receiver. Long run and short run interfaces at three baud rates (a total of six cases) are described.

The parameters for the AC electrical specifications are guided by the XAUI electrical interface specified in Clause 47 of IEEE 802.3ae-2002.

XAUI has similar application goals to serial RapidIO. The goal of this standard is that electrical designs for serial RapidIO can reuse electrical designs for XAUI, suitably modified for applications at the baud intervals and reaches described herein.

Transmitter Specifications

LP-Serial transmitter electrical and timing specifications are stated in the text and tables of this section.

The differential return loss, S11, of the transmitter in each case shall be better than

-10 dB for $(\text{Baud Frequency})/10 < \text{Freq}(f) < 625 \text{ MHz}$, and

-10 dB + $10\log(f/625 \text{ MHz}) \text{ dB}$ for $625 \text{ MHz} \leq \text{Freq}(f) \leq \text{Baud Frequency}$

The reference impedance for the differential return loss measurements is 100 Ohm resistive. Differential return loss includes contributions from on-chip circuitry, chip packaging and any off-chip components related to the driver. The output impedance requirement applies to all valid output levels.

The CPS-10Q satisfies the specification requirement that the 20%-80% rise/fall time of the transmitter, as measured at the transmitter output, in each case has a minimum value 60 ps.

Similarly the timing skew at the output of an LP-Serial transmitter between the two signals that comprise a differential pair does not exceed 25 ps at 1.25 GB, 20 ps at 2.50GB and 15 ps at 3.125 GB.

Symbol	Parameter	Range		Unit	Notes
		Min	Max		
Vo	Output Voltage	-0.40	2.30	Volts	Voltage relative to COMMON of either signal comprising a differential pair.
VODIFF PP	Differential Output Voltage	500	1000	mV p-p	
JD	Deterministic Jitter	-	0.17	UI p-p	
JT	Total Jitter	-	0.35	UI p-p	
SMO	Multiple Output Skew	-	1000	ps	Skew at the transmitter output between lanes of a multilane link
UI	Unit Interval	800	800	ps	+/- 100 ppm

Table 17 Short Run Transmitter AC Timing Specifications - 1.25 GBaud

Symbol	Parameter	Range		Unit	Notes
		Min	Max		
Vo	Output Voltage	-0.40	2.30	Volts	Voltage relative to COMMON of either signal comprising a differential pair.
VODIFF PP	Differential Output Voltage	500	1000	mV p-p	
JD	Deterministic Jitter	-	0.17	UI p-p	
JT	Total Jitter	-	0.35	UI p-p	
SMO	Multiple Output Skew	-	1000	ps	Skew at the transmitter output between lanes of a multilane link
UI	Unit Interval	400	400	ps	+/- 100 ppm

Table 18 Short Run Transmitter AC Timing Specifications - 2.5 GBaud

Symbol	Parameter	Range		Unit	Notes
		Min	Max		
Vo	Output Voltage	-0.40	2.30	Volts	Voltage relative to COMMON of either signal comprising a differential pair.
VODIFF PP	Differential Output Voltage	500	1000	mV p-p	
JD	Deterministic Jitter	-	0.17	UI p-p	
JT	Total Jitter	-	0.35	UI p-p	
SMO	Multiple Output Skew	-	1000	ps	Skew at the transmitter output between lanes of a multilane link
UI	Unit Interval	320	320	ps	+/- 100 ppm

Table 19 Short Run Transmitter AC Timing Specifications - 3.125 GBaud

Symbol	Parameter	Range		Unit	Notes
		Min	Max		
Vo	Output Voltage	-0.40	2.30	Volts	Voltage relative to COMMON of either signal comprising a differential pair.
VODIFF PP	Differential Output Voltage	800	1600	mV p-p	
JD	Deterministic Jitter	-	0.17	UI p-p	
JT	Total Jitter	-	0.35	UI p-p	
SMO	Multiple Output Skew	-	1000	ps	Skew at the transmitter output between lanes of a multilane link
UI	Unit Interval	800	800	ps	+/- 100 ppm

Table 20 Long Run Transmitter AC Timing Specifications - 1.25 GBaud

Symbol	Parameter	Range		Unit	Notes
		Min	Max		
Vo	Output Voltage	-0.40	2.30	Volts	Voltage relative to COMMON of either signal comprising a differential pair.
VODIFF PP	Differential Output Voltage	800	1600	mV p-p	
JD	Deterministic Jitter	-	0.17	UI p-p	
JT	Total Jitter	-	0.35	UI p-p	
SMO	Multiple Output Skew	-	1000	ps	Skew at the transmitter output between lanes of a multilane link
UI	Unit Interval	400	400	ps	+/- 100 ppm

Table 21 Long Run Transmitter AC Timing Specifications - 2.5 GBaud

Symbol	Parameter	Range		Unit	Notes
		Min	Max		
V _O	Output Voltage	-0.40	2.30	Volts	Voltage relative to COMMON of either signal comprising a differential pair.
V _{DIFF PP}	Differential Output Voltage	800	1600	mV p-p	
J _D	Deterministic Jitter	-	0.17	UI p-p	
J _T	Total Jitter	-	0.35	UI p-p	
S _{MO}	Multiple Output Skew	-	1000	ps	Skew at the transmitter output between lanes of a multilane link
UI	Unit Interval	320	320	ps	+/- 100 ppm

Table 22 Long Run Transmitter AC Timing Specifications - 3.125 GBaud

For each baud rate at which an LP-Serial transmitter is specified to operate, the output eye pattern of the transmitter falls entirely within the unshaded portion of the Transmitter Output Compliance Mask shown in Transmitter Output Compliance Mask (Figure 15) with the parameters specified in Transmitter Differential Output Eye Diagram Parameters (Table 17) when measured at the output pins of the device and the device is driving a 100 Ohm +/- 5% differential resistive load. The specification allows the output eye pattern of a LP-Serial transmitter that implements pre-emphasis (to equalize the link and reduce inter-symbol interference) to only comply with the Transmitter Output Compliance Mask when pre-emphasis is disabled or minimized.

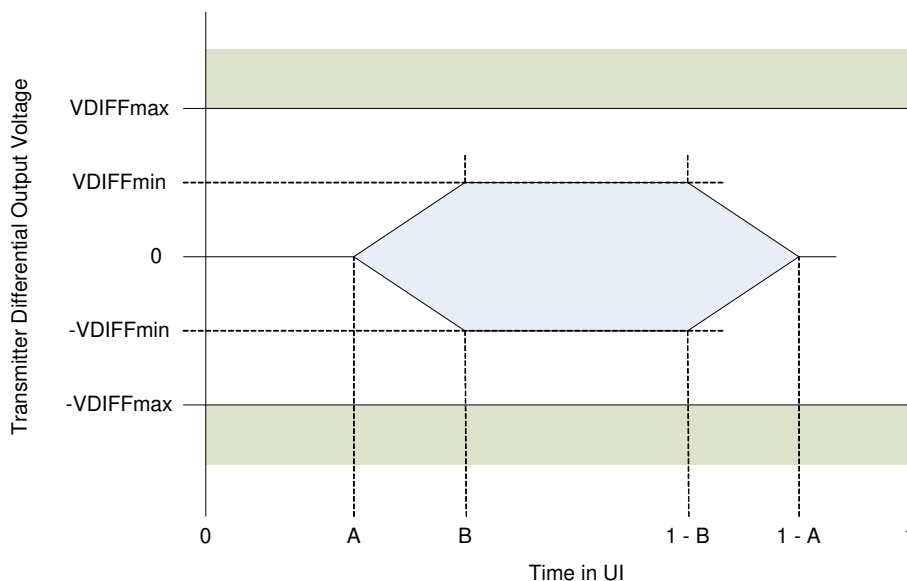

Figure 15 Transmitter Output Compliance Mask

Transmitter Setting	V _{DIFFmin} (mV)	V _{DIFFmax} (mV)	A (UI)	B (UI)
1.25 GBaud Short Range	250	500	0.175	0.39
1.25 GBaud Long Range	400	800	0.175	0.39
2.5 GBaud Short Range	250	500	0.175	0.39
2.5 GBaud Long Range	400	800	0.175	0.39
3.125 GBaud Short Range	250	500	0.175	0.39
3.125 Gbaud Long Range	400	800	0.175	0.39

Table 23 Transmitter Differential Output Eye Diagram Parameters