



Chipsmall Limited consists of a professional team with an average of over 10 year of expertise in the distribution of electronic components. Based in Hongkong, we have already established firm and mutual-benefit business relationships with customers from,Europe,America and south Asia,supplying obsolete and hard-to-find components to meet their specific needs.

With the principle of “Quality Parts,Customers Priority,Honest Operation,and Considerate Service”,our business mainly focus on the distribution of electronic components. Line cards we deal with include Microchip,ALPS,ROHM,Xilinx,Pulse,ON,Everlight and Freescale. Main products comprise IC,Modules,Potentiometer,IC Socket,Relay,Connector.Our parts cover such applications as commercial,industrial, and automotives areas.

We are looking forward to setting up business relationship with you and hope to provide you with the best service and solution. Let us make a better world for our industry!



Contact us

Tel: +86-755-8981 8866 Fax: +86-755-8427 6832

Email & Skype: info@chipsmall.com Web: www.chipsmall.com

Address: A1208, Overseas Decoration Building, #122 Zhenhua RD., Futian, Shenzhen, China



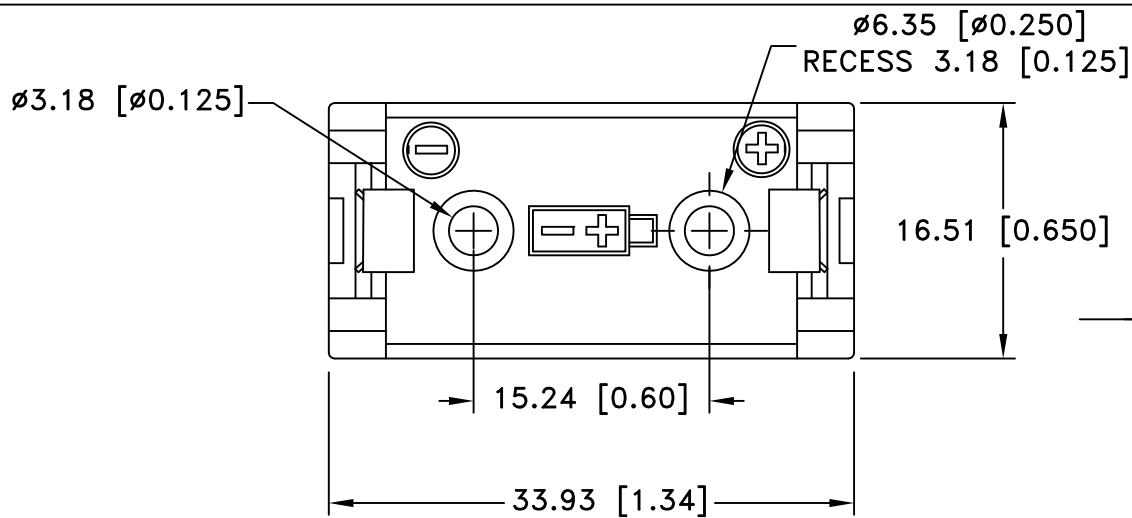

Date	SYM	REVISION RECORD	AUTH	DR.	CK.
6/12/09	B	DIM. Ø1.19 WAS Ø1.17	T.B.	B.S.	
05/14/10	C	DIM. 3.56 WAS 4.57	T.B.	B.S.	
07/15/11	D	UPDATED SPECIFICATION	T.B.	B.S.	

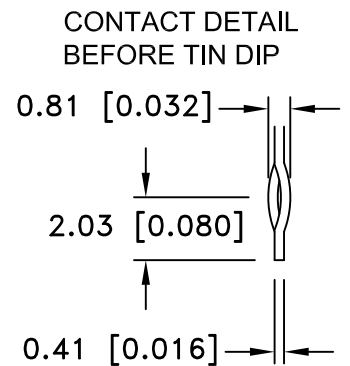
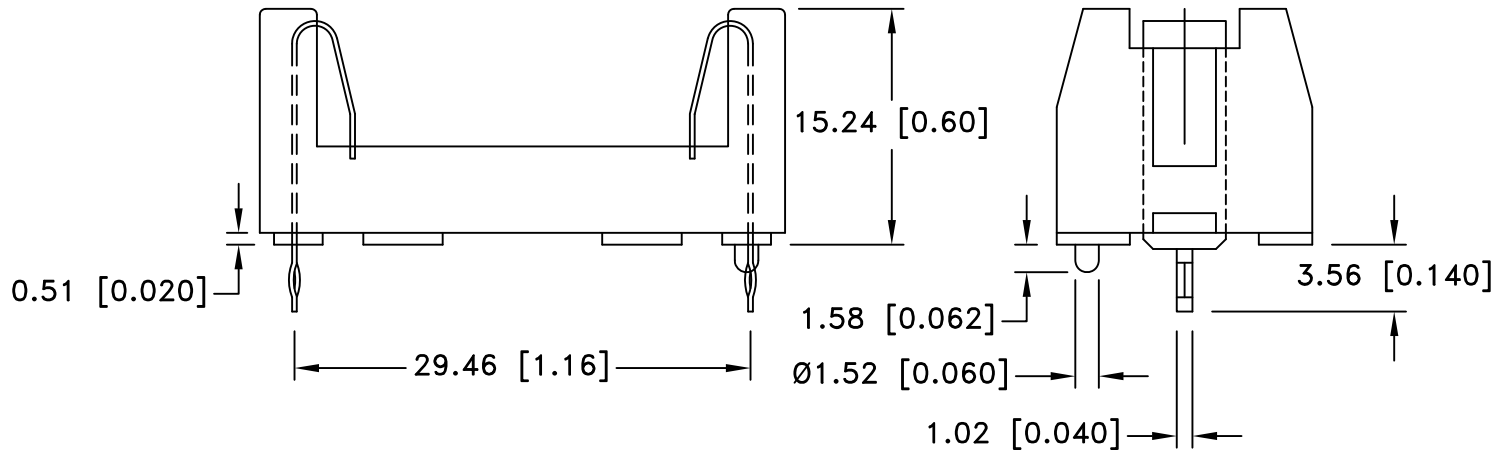
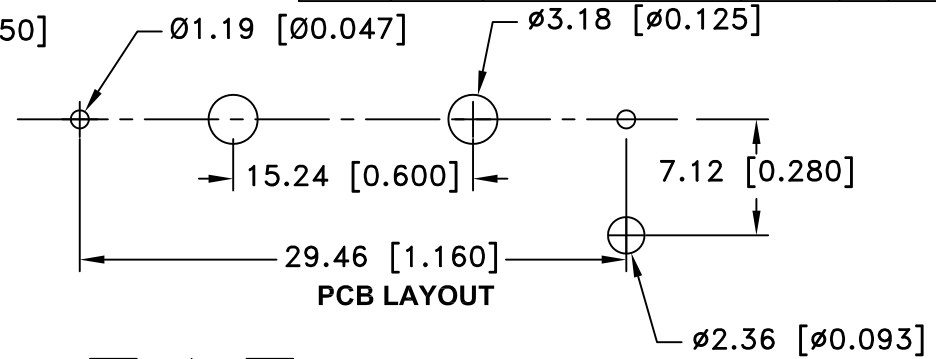

SPECIFICATIONS:

HOLDER MATERIAL: BLACK PBT
 FLAMABILITY RATING:UL94V-0, FILE #E53829
 CONTACTS: 302 SPRING TEMPER STAINLESS STEEL, NICKLE PLATED OVERALL, TIN DIPPED PCB TAILS
 DIELECTRIC STRENGTH: 560 VOLTS/MIL AT 25°C FOR 5 SEC.
 TEMPERATURE RANGE: -55°C TO +180°C
 RESISTANCE TO SOLVENTS: XYLENE, ETHYL , BUTYL, MRTHYL, PROPYL ALCOHOL, ETHYL ACETATE, HEPTANE, TOLUENE, REFRIGERANT

ROHS COMPLIANT

NOTES:
 EYELET STIMPSON STYLE#A1883 0.110" OD x 0.190" FLANGE
 FLANGE RECESS Ø0.250" x 0.125" DEEP
 ACCEPTS STANDARD 2-56 MACHINE SCREWS

Tolerance (Except as noted)	 Memory Protection Devices, Inc 200 Broad Hollow Road, Farmingdale, New York 11735	Scale	Drawn By B.S.
			Approved By T.B.
decimal ±.5 (.020)	Title 1/2AA BATTERY HOLDER, PCB MOUNTING		
Fractional ± .8 (.030)		Date 07/15/11	Drawing Number 815-0931
Angular ± 3°			