



Chipsmall Limited consists of a professional team with an average of over 10 year of expertise in the distribution of electronic components. Based in Hongkong, we have already established firm and mutual-benefit business relationships with customers from,Europe,America and south Asia,supplying obsolete and hard-to-find components to meet their specific needs.

With the principle of “Quality Parts,Customers Priority,Honest Operation,and Considerate Service”,our business mainly focus on the distribution of electronic components. Line cards we deal with include Microchip,ALPS,ROHM,Xilinx,Pulse,ON,Everlight and Freescale. Main products comprise IC,Modules,Potentiometer,IC Socket,Relay,Connector.Our parts cover such applications as commercial,industrial, and automotives areas.

We are looking forward to setting up business relationship with you and hope to provide you with the best service and solution. Let us make a better world for our industry!



Contact us

Tel: +86-755-8981 8866 Fax: +86-755-8427 6832

Email & Skype: info@chipsmall.com Web: www.chipsmall.com

Address: A1208, Overseas Decoration Building, #122 Zhenhua RD., Futian, Shenzhen, China



820B YYY - 2 1 3 R 00 1

SERIES 9.50 [0.374]
 # OF POSITIONS (Ex. 002)
 SEE CHART A
 2 = FEMALE
 VERTICAL (PANEL MOUNT)
 1 = GOLD FLASH
 RoHS COMPLIANT
 NICKEL/CHROME PLATED SHELL

CHARACTERISSTICS

MATERIALS

SHELL : BRASS
 SHELL PLATING : NICKEL
 NUT : BRASS
 NUT PLATING : NICKEL
 LATCH SLEEVE : BRASS
 LATCH SLEEVE PLATING : NICKEL
 CONTACTS : COPPER ALLOY
 CONTACT PLATING : 7µ" GOLD PLATED OVER 196µ" NICKEL MIN.
 INSULATOR : PPS (HIGH TEMPERATURE)

MECHANICAL

DURABILITY: 5000 CYCLES
 OPERATING TEMP. RANGE: -40°C ~ +200°C
 PROCESS TEMPERATURE : 260°C FOR 5 SECONDS
 MAX. TORQUE VALUE : 2.5 Nm [22.1 IN/lbs]
 SHIELDING : 75dB @ 10MHz
 40dB @ 1GHz

IP RATING: 50

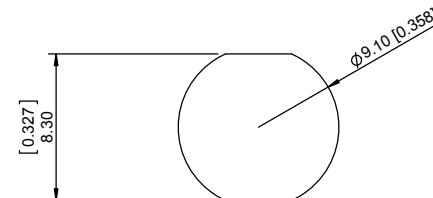
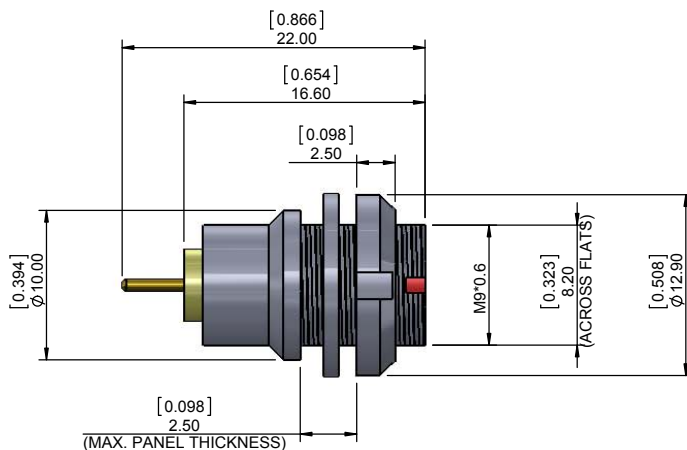

PANEL CUTOUT

TOLERANCE = +0.10, -0.0
 [+0.004, -0.00]

CHART A

● = KEY LOCATION

VIEW FROM TERMINATION END

 2 POSITION 10 AMP MAX. PIN Ø = 0.90 [0.035]	 3 POSITION 8 AMP MAX. PIN Ø = 0.90 [0.035]	 4 POSITION 7 AMP MAX. PIN Ø = 0.70 [0.028]	 5 POSITION 6.5 AMP MAX. PIN Ø = 0.70 [0.028]	 6 POSITION 2.5 AMP MAX. PIN Ø = 0.50 [0.020]	 7 POSITION 2.5 AMP MAX. PIN Ø = 0.50 [0.020]	 9 POSITION 2 AMP MAX. PIN Ø = 0.50 [0.020]
CONTACT RESISTANCE = 6 mΩ TEST VOLTAGE = 1300V WORKING VOLTAGE = 430V	CONTACT RESISTANCE = 6 mΩ TEST VOLTAGE = 1200V WORKING VOLTAGE = 400V	CONTACT RESISTANCE = 7.5 mΩ TEST VOLTAGE = 850V WORKING VOLTAGE = 280V	CONTACT RESISTANCE = 7.5 mΩ TEST VOLTAGE = 850V WORKING VOLTAGE = 280V	CONTACT RESISTANCE = 10 mΩ TEST VOLTAGE = 850V WORKING VOLTAGE = 280V	CONTACT RESISTANCE = 10 mΩ TEST VOLTAGE = 800V WORKING VOLTAGE = 260V	CONTACT RESISTANCE = 10 mΩ TEST VOLTAGE = 600V WORKING VOLTAGE = 200V

****NO TEST****
SEE PAGE 2 FOR BOARD LAYOUTS

RoHS COMPLIANT



THESE DRAWINGS AND SPECIFICATIONS ARE THE PROPERTY OF No rComp AND SHALL NOT BE REPRODUCED, COPIED OR USED AS THE BASIS FOR THE MANUFACTURE OR SALE OF APPARATUS WITHOU TWRITTEN PERMISSION.

No rComp

DRAWN: M. SIGMON	DATE: 02-08-16	SCALE: N.T.S.	SHEET 1 OF 2	REV: 1
CHECKED:	DATE:		DWG NO. 820BYYY-213R001	

BOARD LAYOUTS

● = KEY LOCATION

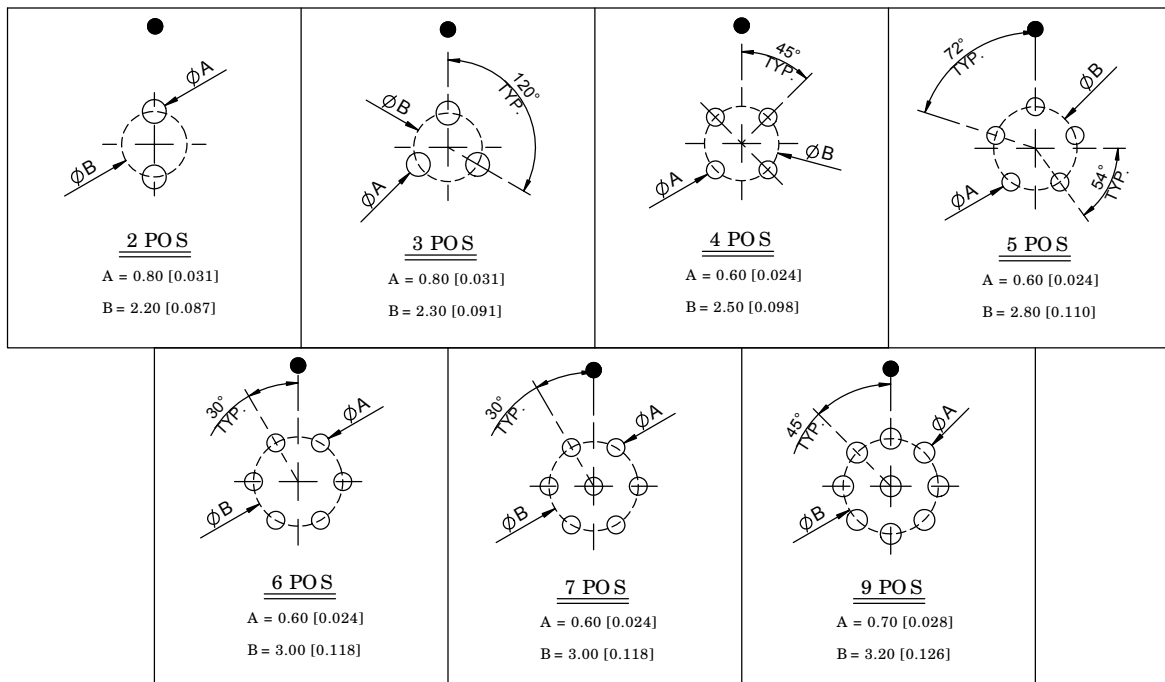

RoHS COMPLIANT

THESE DRAWINGS AND SPECIFICATIONS ARE THE PROPERTY OF No rComp AND SHALL NOT BE REPRODUCED, COPIED OR USED AS THE BASIS FOR THE MANUFACTURE OR SALE OF APPARATUS WITHO UT WRITTEN PERMISSION.

No rC o m p

DRAWN:
M. SIGMON

DATE:
02-08-16

SCALE:
N.T.S.

SHEET OF
2 2

REV:
0

CHECKED:

DATE:

DWG NO.

820BYYY-213R001