



Chipsmall Limited consists of a professional team with an average of over 10 year of expertise in the distribution of electronic components. Based in Hongkong, we have already established firm and mutual-benefit business relationships with customers from,Europe,America and south Asia,supplying obsolete and hard-to-find components to meet their specific needs.

With the principle of “Quality Parts,Customers Priority,Honest Operation,and Considerate Service”,our business mainly focus on the distribution of electronic components. Line cards we deal with include Microchip,ALPS,ROHM,Xilinx,Pulse,ON,Everlight and Freescale. Main products comprise IC,Modules,Potentiometer,IC Socket,Relay,Connector.Our parts cover such applications as commercial,industrial, and automotives areas.

We are looking forward to setting up business relationship with you and hope to provide you with the best service and solution. Let us make a better world for our industry!



Contact us

Tel: +86-755-8981 8866 Fax: +86-755-8427 6832

Email & Skype: info@chipsmall.com Web: www.chipsmall.com

Address: A1208, Overseas Decoration Building, #122 Zhenhua RD., Futian, Shenzhen, China



821B YYY - 1 7 3 L YY 1

SERIES 12.00 [0.475]
 # OF POSITIONS (Ex. 002)
 SEE CHART A
 1 = MALE
 CABLE MOUNT
 1 = GOLD FLASH
 COLLET SIZE **SEE CHART B**
 RoHS COMPLIANT
 NICKEL/CHROME PLATED SHELL

CHARACTERISSTICS

MATERIALS

HOUSING : BRASS
 HOUSING PLATING : 196µ" NICKEL MIN.
 SHELL & COLLET NUT: BRASS, 196µ" CHROME PLATED MIN.
 CONTACTS : COPPER ALLOY
 CONTACT PLATING : 7µ" GOLD PLATED OVER 196µ" NICKEL MIN.
 INSULATOR : PPS (HIGH TEMPERATURE)
 STRAIN RELIEF(BOOT) : THERMOPLASTIC POLYURETHANE

MECHANICAL

DURABILITY: 5000 CYCLES
 OPERATING TEMP. RANGE: -40° C ~ +200° C
 PROCESS TEMPERATURE : 260°C FOR 5 SECONDS
 MAX. TOURQUE VALUE : 1.5 Nm [13.2 IN/LBS]
 SHIELDING: 75dB @ 10MHz
 40dB @ 1GHz

IP RATING: 50

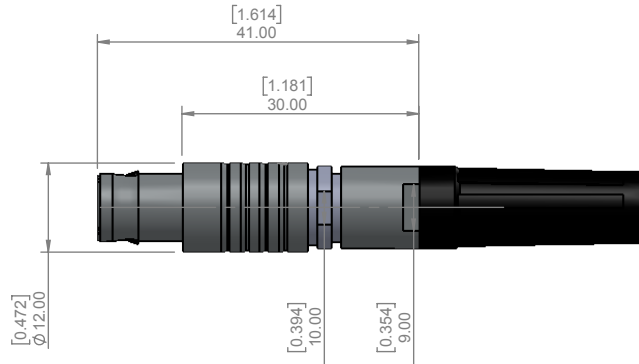

CHART B

COLLET SIZE	WIRE DIAMETER
40	3.30 [0.130] ~ 4.20 [0.165]
50	4.30 [0.169] ~ 5.20 [0.205]
60	5.30 [0.209] ~ 6.20 [0.244]
70	6.30 [0.248] ~ 7.20 [0.283]

CHART A

● = KEY LOCATION

VIEW FROM TERMINATION END

 2 POSITION 20 AWG MAX. 15 AMP MAX. PIN Ø = 1.30 [0.051] CONTACT RESISTANCE = 5 mΩ TEST VOLTAGE = 1500V WORKING VOLTAGE = 500V	 3 POSITION 20 AWG MAX. 12 AMP MAX. PIN Ø = 1.30 [0.051]	 4 POSITION 22 AWG MAX. 10 AMP MAX. PIN Ø = 0.90 [0.035]	 5 POSITION 22 AWG MAX. 9 AMP MAX. PIN Ø = 0.90 [0.035]	 6 POSITION 24 AWG MAX. 7 AMP MAX. PIN Ø = 0.70 [0.028]	 7 POSITION 24 AWG MAX. 7 AMP MAX. PIN Ø = 0.70 [0.028]	 8 POSITION 24 AWG MAX. 5 AMP MAX. PIN Ø = 0.70 [0.028]	 10 POSITION 28 AWG MAX. 2.5 AMP MAX. PIN Ø = 0.50 [0.020]	 14 POSITION 28 AWG MAX. 2 AMP MAX. PIN Ø = 0.50 [0.020]
---	--	--	---	---	---	---	--	--

RoHS COMPLIANT



THESE DRAWINGS AND SPECIFICATIONS ARE THE PROPERTY OF NorComp AND SHALL NOT BE REPRODUCED, COPIED OR USED AS THE BASIS FOR THE MANUFACTURE OR SALE OF APPARATUS WITHOUT WRITTEN PERMISSION.

NorComp

DRAWN: M. SIGMON	DATE: 02-03-16	SCALE: N.T.S.	SHEET 1 OF 1	REV: 6
CHECKED:	DATE:		DWG NO. 821BYYY-173LYY1	