



Chipsmall Limited consists of a professional team with an average of over 10 year of expertise in the distribution of electronic components. Based in Hongkong, we have already established firm and mutual-benefit business relationships with customers from,Europe,America and south Asia,supplying obsolete and hard-to-find components to meet their specific needs.

With the principle of "Quality Parts,Customers Priority,Honest Operation,and Considerate Service",our business mainly focus on the distribution of electronic components. Line cards we deal with include Microchip,ALPS,ROHM,Xilinx,Pulse,ON,Everlight and Freescale. Main products comprise IC,Modules,Potentiometer,IC Socket,Relay,Connector.Our parts cover such applications as commercial,industrial, and automotives areas.

We are looking forward to setting up business relationship with you and hope to provide you with the best service and solution. Let us make a better world for our industry!



Contact us

Tel: +86-755-8981 8866 Fax: +86-755-8427 6832

Email & Skype: info@chipsmall.com Web: www.chipsmall.com

Address: A1208, Overseas Decoration Building, #122 Zhenhua RD., Futian, Shenzhen, China



THIS DRAWING IS UNPUBLISHED. RELEASED FOR PUBLICATION
 © COPYRIGHT BY TYCO ELECTRONICS CORPORATION. ALL INTERNATIONAL RIGHTS RESERVED.

| LOC | | DIST | | REVISIONS | | | |
|-----|-----|-------------|--|---------------------------|---------|-------|--|
| P | LTR | DESCRIPTION | | DATE | DWN | APVD | |
| AG | 0 | G1 | | REVISED PER ECO-09-008864 | 11JUN09 | DH MB | |

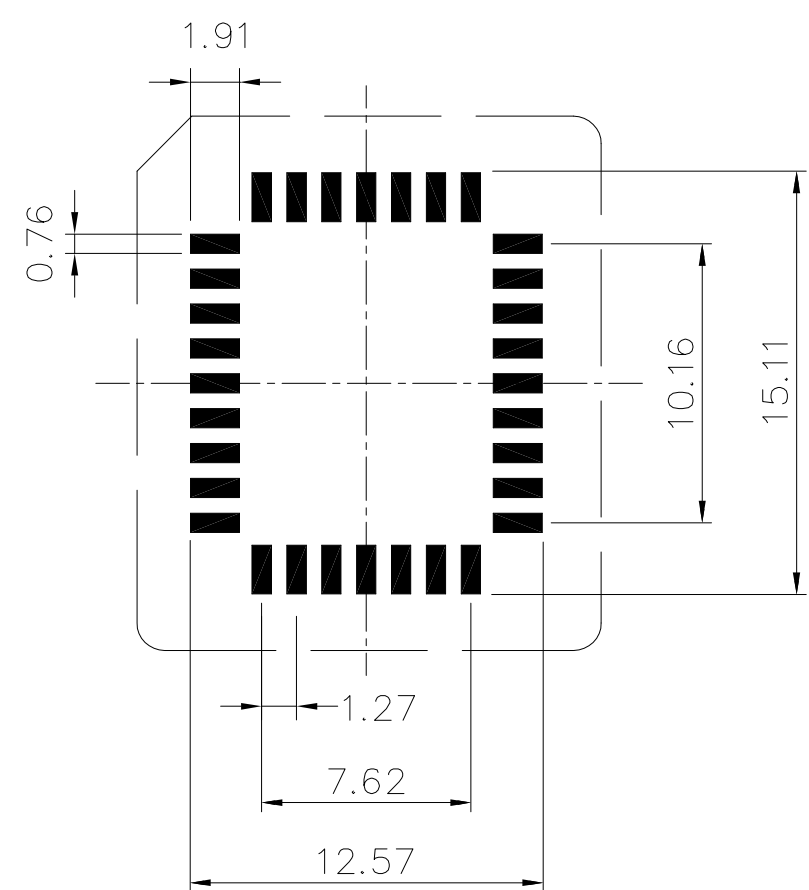
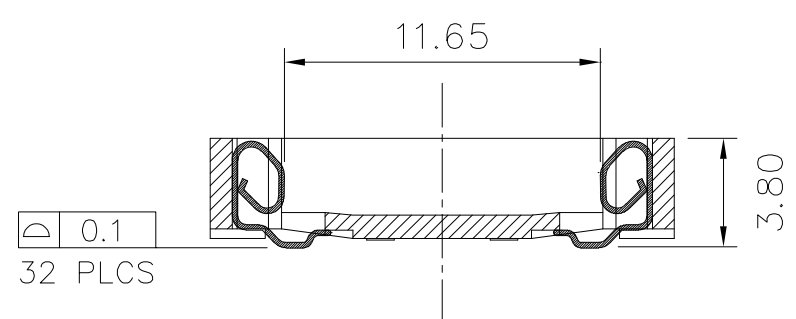
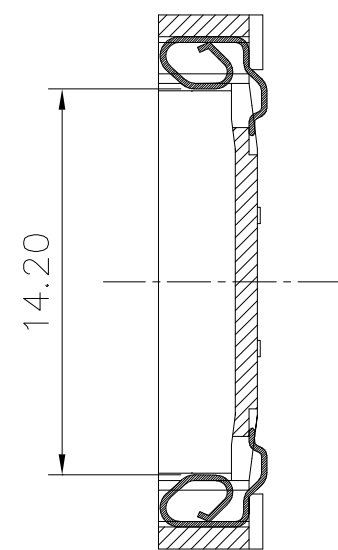
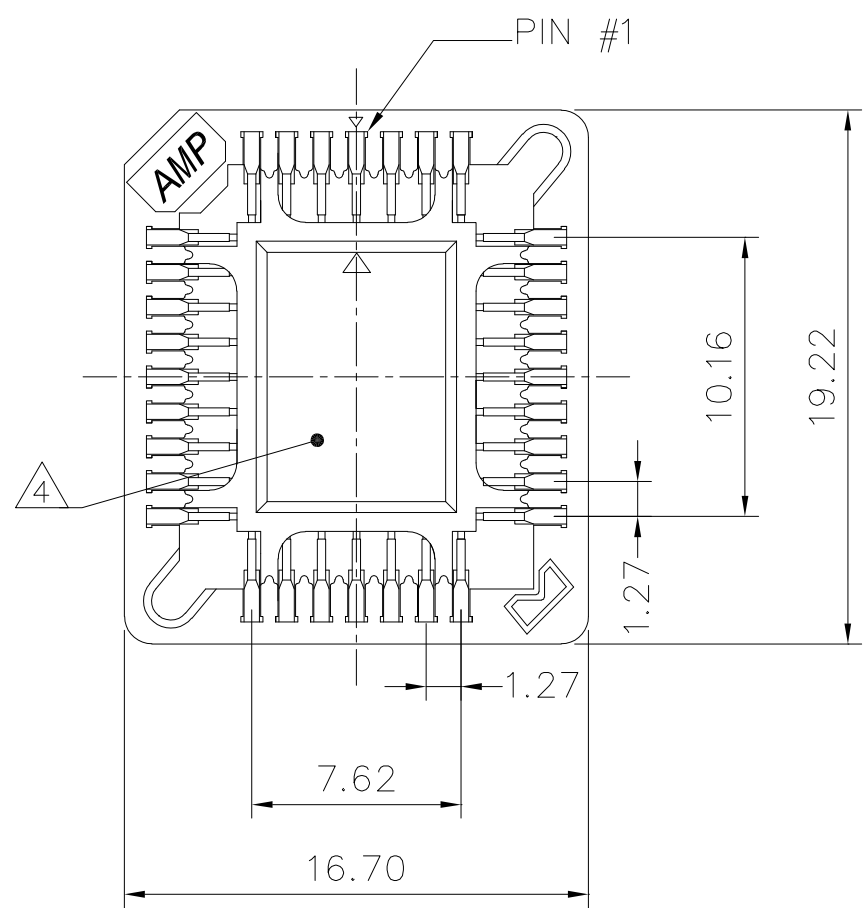

P.C.B. LAYOUT

- 1 MATERIALS:
HOUSING - HIGH TEMPERATURE THERMOPLASTIC, UL94V-0, COLOR: BROWN.
CONTACT - PHOSPHOR BRONZE.
- 2 FINISH, CONTACT: 0.0038 MIN 100% TIN OVER 0.0011 MIN NICKEL.
- 3. PLCC DEVICE SHALL CONFORM TO JEDEC STANDARD MS-016.
- 4 HOUSING FLOOR TO BE SMOOTH WITHIN A 5.20 DIAMETER FOR VACUUM PLACEMENT.
- 5 TAPE PACKAGING TO CONFORM TO EIA RS-481-3. TAPE WIDTH SHALL BE 32mm, TAPE PITCH SHALL BE 24mm, AND REEL DIAMETER SHALL BE 330mm.
- 6. PLCC EXTRACTION TOOL: AMP PART NUMBER 821980-1 OR 822476-1.
- 7. PRODUCT DESIGN OBJECTIVES:
CURRENT RATING: 1 AMP, MAXIMUM
CONTACT RESISTANCE: 20 MILLIOHMS, MAXIMUM
DIELECTRIC WITHSTAND VOLTAGE: 600VAC, RMS, MINIMUM
INSULATION RESISTANCE: 5,000 MEGOHMS, MINIMUM
DURABILITY: 25 CYCLES
OPERATING TEMPERATURE RANGE: -55 TO +105C
MATING FORCE: 9.0 Kg, MAXIMUM
- 8 FINISH, CONTACT: 0.0038 MIN 93/7 TIN-LEAD OVER 0.0011 MIN NICKEL.
- 9 TUBE LENGTH 535mm. EXTERNAL CARTON 580 x 240 x 260mm TO HOLD 8,008 PIECES.
- 10 OBSOLETE PART NUMBER.

| NOTES | FINISH | TUBES OR REELS/BOX | PCS/REEL OR TUBE | PACKAGING STYLE | AMP PART NUMBER |
|-------|--------|--------------------|------------------|-----------------|-----------------|
| - | 2 9 | 308 | 26 | TUBES | 822475-3 |
| - | 2 5 | 5 | 500 | TAPE AND REEL | 822475-2 |
| 10 | 8 5 | 5 | 500 | TAPE AND REEL | 822475-1 |

| | | | | | |
|--|--|--------------------------------|---|-----------|------------|
| THIS DRAWING IS A CONTROLLED DOCUMENT. | | DWN A. HOLT 19OCT99 | Tyco Electronics Corporation Harrisburg, PA 17105-3608 | | |
| DIMENSIONS: mm | TOLERANCES UNLESS OTHERWISE SPECIFIED: | CHK K. KREIDLER 18OCT99 | NAME SOCKET, MINI-PLCC, SURFACE MOUNT, 32 POSITION | | |
| | 0 PLC ± - | APVD K. KREIDLER 18OCT99 | SIZE | CAGE CODE | DRAWING NO |
| | 1 PLC ± - | PRODUCT SPEC | RESTRICTED TO | | |
| | 2 PLC ± 0.20 | APPLICATION SPEC | SCALE 3:1 SHEET 1 OF 1 REV G1 | | |
| | 3 PLC ± - | FINISH | WEIGHT 0.9 GRAMS A2 00779 C=822475 | | |
| | 4 PLC ± - | SEE TABLE | CUSTOMER DRAWING | | |
| | ANGLES ± - | | | | |

822475